

C919

Aircraft Characteristics for Airport Planning

ACAP

Number: C919-SVV19-50009-00



Commercial Aircraft Corporation of China, Ltd.

Original:2022.10.20

R8 : 2024.10.18

Intentionally left blank

Users of this technical publication shall comply with all laws and regulations on export controls and economic sanctions of any country/region applicable to the technical publications of the Commercial Aircraft Corporation of China, Ltd. ("COMAC") for the use, disclosure, management, distribution and any other utilization of this publication.

**COMMERCIAL AIRCRAFT CORPORATION OF CHINA, LTD.
PROPRIETARY, CONFIDENTIAL, AND/OR TRADE SECRET**

Copyright© 2024

COMAC - Commercial Aircraft Corporation of China, Ltd. All Rights Reserved

Statement

COMAC claims copyright on each page of this document only to the extent that the page contains copyrightable subject matter. COMAC also claims copyright on this document as a compilation and/or collective work.

The information contained herein is the proprietary information of COMAC. The information contained herein shall not be reproduced, quoted, disclosed or used directly or indirectly, in whole or in part for any purposes, except with prior written authorization by COMAC. If written authorization is given for reproduction in whole or in part, this statement shall appear intact in such reproduction. Any unauthorized receiver shall notify COMAC and return this document and all other reproductions to COMAC immediately.

The COMAC company name and logo containing "COMAC", the ARJ21 name and logo containing "ARJ21" and the C919 name and logo containing "C919" are all trademarks owned by the Commercial Aircraft Corporation of China, Ltd. No trademark license (either expressed or implied) is granted related to this document unless provided in writing by COMAC.

Intentionally left blank

TRANSMITTAL LETTER

2024.10.18

To: All holders of this technical publication.

This revision is applicable to Aircraft Characteristics for Airport Planning.

REVISION DESCRIPTION

For printed technical publications, pages shall be replaced or inserted as per the List of Effective Data Modules (LEDM). In the LEDM, amendments proceeded by the letters C, N, D and RR refer to Changed, New, Deleted and Reinstated revised. Changed and deleted pages in this revision shall be removed and destroyed.

For electronic manuals, this revision supersedes all previous revisions.

If you receive printed revisions, please confirm that you have received and filed the previous revision. In case of lost or missing items, please contact COMAC for replacement copies.

Contact:

Shanghai Aircraft Customer Service Co., Ltd.

Address: 100 East Jiangchuan Road, Minhang District, Shanghai, China

Tel: +86 18019195120

Mail: rrc@comac.cc

Intentionally left blank

General Highlights

Data Module	Description of Change	Applicable to
C919-A-00-00-00-00A-021A-A	Revised	ALL
C919-A-19-20-02-07A-04AA-A	Figure added, updated or deleted	ALL
C919-A-19-20-02-08A-04AA-A	Figure added, updated or deleted	ALL
C919-A-19-20-05-14A-04AA-A	Towbar design guidelines content added, updated	ALL

Intentionally left blank

Table of contents

<u>Document title</u>	<u>Data module code</u>	<u>Number of pages</u>	<u>Applicable to</u>
Title page -	C919-A-00-40-23-00A-001A-A		ALL
Copyright Information -	C919-A-00-00-00-00A-021A-A		ALL
Transmittal Letter -	C919-A-00-00-00-00A-023B-A		ALL
General - Highlights	C919-A-00-40-23-03A-00UA-A		ALL
Table of contents - Table of contents	C919-A-00-40-02-00A-009A-A		ALL
Introduction - List of Effective Chapter/Section	C919-A-00-40-00-00A-00SA-A		ALL
Symbols and Abbreviations -	C919-A-00-40-23-01A-018A-A		ALL
Introduction -	C919-A-00-40-23-02A-018A-A		ALL
Scope - General introduction	C919-A-19-20-01-01A-01BA-A		ALL
Introduction - General introduction	C919-A-19-20-01-02A-01BA-A		ALL
A Brief Description of the Aircraft - General introduction	C919-A-19-20-01-03A-01BA-A		ALL
General Aircraft Characteristics - System description	C919-A-19-20-02-01A-04AA-A		ALL
General Aircraft Dimensions - System description	C919-A-19-20-02-02A-04AA-A		ALL
Ground Clearances - System description	C919-A-19-20-02-03A-04AA-A		ALL
Interior Arrangements - System description	C919-A-19-20-02-04A-04AA-A		ALL
Passenger Compartment Cross-Section - System description	C919-A-19-20-02-05A-04AA-A		ALL
Lower Deck Compartments - System description	C919-A-19-20-02-06A-04AA-A		ALL
Door Clearances - System description	C919-A-19-20-02-07A-04AA-A		ALL

Aircraft Characteristics for Airport Planning

<u>Document title</u>	<u>Data module code</u>	<u>Number of pages</u>	<u>Applicable to</u>
Evacuation Slide - System Description	C919-A-19-20-02-08A-04AA-A		ALL
Landing Gear - System Description	C919-A-19-20-02-09A-04AA-A		ALL
Exterior Lighting - System Description	C919-A-19-20-02-10A-04AA-A		ALL
Antenna Locations - System Description	C919-A-19-20-02-11A-04AA-A		ALL
Power Plant - System Description	C919-A-19-20-02-12A-04AA-A		ALL
Leveling/Weighting - System Description	C919-A-19-20-02-13A-04AA-A		ALL
Jacking - System Description	C919-A-19-20-02-14A-04AA-A		ALL
General Information - Performance	C919-A-19-20-03-01A-03CA-A		ALL
Payload/Range - Performance	C919-A-19-20-03-02A-03CA-A		ALL
Takeoff Runway Length - Performance	C919-A-19-20-03-03A-03CA-A		ALL
Landing Field Length - Performance	C919-A-19-20-03-04A-03CA-A		ALL
Landing Reference Speed - Performance	C919-A-19-20-03-05A-03CA-A		ALL
General Information - System Description	C919-A-19-20-04-01A-04AA-A		ALL
Turning Radii, No Slip Angle - System Description	C919-A-19-20-04-02A-04AA-A		ALL
Minimum Turning Radius - System Description	C919-A-19-20-04-03A-04AA-A		ALL
Visibility from Cockpit in Static Position - System Description	C919-A-19-20-04-04A-04AA-A		ALL
Runway and Taxiway Turn Paths - System Description	C919-A-19-20-04-05A-04AA-A		ALL
Runway Holding Bay - System Description	C919-A-19-20-04-06A-04AA-A		ALL



<u>Document title</u>	<u>Data module code</u>	<u>Number of pages</u>	<u>Applicable to</u>
Mooring - System Description	C919-A-19-20-04-07A-84AA-A		ALL
Aircraft Ramp Equipment Layout - System description	C919-A-19-20-05-01A-04AA-A		ALL
Terminal Operations - System description	C919-A-19-20-05-02A-04AA-A		ALL
Ground Service Connections - System description	C919-A-19-20-05-03A-04AA-A		ALL
Engine Starting Pneumatic Requirements - System description	C919-A-19-20-05-04A-04AA-A		ALL
Ground Pneumatic Requirements - System description	C919-A-19-20-05-05A-04AA-A		ALL
Preconditioned Airflow Requirements - System description	C919-A-19-20-05-06A-04AA-A		ALL
Hydraulic System - System Description	C919-A-19-20-05-07A-84AA-A		ALL
Electrical Power System - System Description	C919-A-19-20-05-08A-84AA-A		ALL
Oxygen System - System Description	C919-A-19-20-05-09A-84AA-A		ALL
Fuel System - System Description	C919-A-19-20-05-10A-84AA-A		ALL
Pneumatic System - System Description	C919-A-19-20-05-11A-84AA-A		ALL
Power Plant - System Description	C919-A-19-20-05-12A-84AA-A		ALL
Water/Waste System - System Description	C919-A-19-20-05-13A-84AA-A		ALL
Towing - System Description	C919-A-19-20-05-14A-04AA-A		ALL
Jet Engine Exhaust Temperatures - System description	C919-A-19-20-06-01A-04AA-A		ALL
Airport and Community Noise - System description	C919-A-19-20-06-02A-04AA-A		ALL
Jet Engine Exhaust Velocities and Danger Areas - System description	C919-A-19-20-06-03A-04AA-A		ALL

Aircraft Characteristics for Airport Planning

<u>Document title</u>	<u>Data module code</u>	<u>Number of pages</u>	<u>Applicable to</u>
APU Exhaust Velocities and Temperatures - System description	C919-A-19-20-06-04A-04AA-A		ALL
General Information - System description	C919-A-19-20-07-01A-04AA-A		ALL
Landing Gear Footprint - System description	C919-A-19-20-07-02A-04AA-A		ALL
Maximum Pavement Loads - System description	C919-A-19-20-07-03A-04AA-A		ALL
Landing Gear Loading on Pavement - System description	C919-A-19-20-07-04A-04AA-A		ALL
Flexible Pavement Requirements - System description	C919-A-19-20-07-05A-04AA-A		ALL
Flexible Pavement Requirements LCN Conversion - System description	C919-A-19-20-07-06A-04AA-A		ALL
Rigid Pavement Requirements Portland Cement Association(PCA) - System description	C919-A-19-20-07-07A-04AA-A		ALL
Rigid Pavement Requirements LCN Conversion - System Description	C919-A-19-20-07-08A-04AA-A		ALL
ACN/PCN Reporting System - Flexible and Rigid Pavements - System Description	C919-A-19-20-07-09A-04AA-A		ALL
ACR/PCR Reporting System - Flexible and Rigid Pavements	C919-A-19-20-07-10A-04AA-A		ALL

Introduction

List of Effective Chapter/Section

Code N, C, D or RR indicates data modules which are New, Changed, Deleted or Reinstated revised respectively.

Data module code	Revision Status	Issue Date
C919-A-00-40-23-00A-001A-A	C	2024.10.18
C919-A-00-00-00-00A-021A-A	C	2024.10.18
C919-A-00-00-00-00A-023B-A	C	2024.10.18
C919-A-00-40-23-03A-00UA-A	C	2024.10.18
C919-A-00-40-02-00A-009A-A	C	2024.10.18
C919-A-00-40-00-00A-00SA-A	C	2024.10.18
C919-A-00-40-23-01A-018A-A		2022.10.20
C919-A-00-40-23-02A-018A-A		2022.10.20
C919-A-00-10-00-00A-009C-D		2024.10.18
C919-A-19-20-01-01A-01BA-A		2022.10.20
C919-A-19-20-01-02A-01BA-A		2022.10.20
C919-A-19-20-01-03A-01BA-A		2023.08.21
C919-A-00-10-00-01A-009C-D		2024.10.18
C919-A-19-20-02-01A-04AA-A		2023.08.21
C919-A-19-20-02-02A-04AA-A		2023.08.21
C919-A-19-20-02-03A-04AA-A		2022.10.20
C919-A-19-20-02-04A-04AA-A		2023.08.21
C919-A-19-20-02-05A-04AA-A		2023.01.29
C919-A-19-20-02-06A-04AA-A		2024.06.28
C919-A-19-20-02-07A-04AA-A	C	2024.10.18
C919-A-19-20-02-08A-04AA-A	C	2024.10.18
C919-A-19-20-02-09A-04AA-A		2023.08.21
C919-A-19-20-02-10A-04AA-A		2023.08.21
C919-A-19-20-02-11A-04AA-A		2023.08.21
C919-A-19-20-02-12A-04AA-A		2023.08.21
C919-A-19-20-02-13A-04AA-A		2023.01.29
C919-A-19-20-02-14A-04AA-A		2022.10.20
C919-A-00-10-00-02A-009C-D		2024.10.18
C919-A-19-20-03-01A-03CA-A		2022.10.20
C919-A-19-20-03-02A-03CA-A		2022.10.20



Aircraft Characteristics for Airport Planning

Data module code	Revision Status	Issue Date
C919-A-19-20-03-03A-03CA-A		2022.10.20
C919-A-19-20-03-04A-03CA-A		2023.01.29
C919-A-19-20-03-05A-03CA-A		2024.06.28
C919-A-00-10-00-03A-009C-D		2024.10.18
C919-A-19-20-04-01A-04AA-A		2023.08.21
C919-A-19-20-04-02A-04AA-A		2022.10.20
C919-A-19-20-04-03A-04AA-A		2023.08.21
C919-A-19-20-04-04A-04AA-A		2022.10.20
C919-A-19-20-04-05A-04AA-A		2022.10.20
C919-A-19-20-04-06A-04AA-A		2022.10.20
C919-A-19-20-04-07A-84AA-A		2023.08.21
C919-A-00-10-00-04A-009C-D		2024.10.18
C919-A-19-20-05-01A-04AA-A		2023.08.21
C919-A-19-20-05-02A-04AA-A		2023.08.21
C919-A-19-20-05-03A-04AA-A		2023.08.21
C919-A-19-20-05-04A-04AA-A		2022.10.20
C919-A-19-20-05-05A-04AA-A		2022.10.20
C919-A-19-20-05-06A-04AA-A		2022.10.20
C919-A-19-20-05-07A-84AA-A		2023.08.21
C919-A-19-20-05-08A-84AA-A		2023.08.21
C919-A-19-20-05-09A-84AA-A		2024.06.28
C919-A-19-20-05-10A-84AA-A		2023.08.21
C919-A-19-20-05-11A-84AA-A		2023.08.21
C919-A-19-20-05-12A-84AA-A		2023.08.21
C919-A-19-20-05-13A-84AA-A		2023.08.21
C919-A-19-20-05-14A-04AA-A	C	2024.10.18
C919-A-00-10-00-05A-009C-D		2024.10.18
C919-A-19-20-06-01A-04AA-A		2022.10.20
C919-A-19-20-06-02A-04AA-A		2022.10.20
C919-A-19-20-06-03A-04AA-A		2022.10.20
C919-A-19-20-06-04A-04AA-A		2022.10.20
C919-A-00-10-00-06A-009C-D		2024.10.18
C919-A-19-20-07-01A-04AA-A		2024.06.28
C919-A-19-20-07-02A-04AA-A		2024.06.28

Data module code	Revision Status	Issue Date
C919-A-19-20-07-03A-04AA-A		2022.10.20
C919-A-19-20-07-04A-04AA-A		2022.10.20
C919-A-19-20-07-05A-04AA-A		2022.10.20
C919-A-19-20-07-06A-04AA-A		2022.10.20
C919-A-19-20-07-07A-04AA-A		2022.10.20
C919-A-19-20-07-08A-04AA-A		2022.10.20
C919-A-19-20-07-09A-04AA-A		2022.10.20
C919-A-19-20-07-10A-04AA-A		2024.06.28

Intentionally left blank

Symbols and Abbreviations

1. Abbreviations

Table 1 Abbreviations

Abbreviation	Full Name
ACN	Aircraft Classification Number
APU	AUXILIARY POWER UNIT
CBR	California Bearing Ratio
CG	Center of Gravity
E	Young's modulus
FWD	Forward
ICAO	International Civil Aviation Organization
ISA	International Standard Atmosphere
k	Subgrade Strength
KCAS	Calibrated Air Speed in Knot
LCD	Liquid Crystal Display
LCN	Load Classification Number
MLG	Main Landing Gear
MAX	Maximum
MLW	Maximum Design Landing Weight
MTOW	Maximum Design Takeoff Weight
MTW	Maximum Design Taxi Weight
MZFW	Maximum Design Zero Fuel Weight
OAT	Outside Air Temperature
OEW	Operating Empty Weight
PCA	Portland Cement Association
PCN	Pavement Classification Number
R	Right/Radius
RAT	Ram Air Turbine
VREF	Landing Reference Speed
W	Weight

2. Symbols

**Aircraft Characteristics for Airport
Planning**
Table 2 Symbols

Symbol	Full Name
°	Degree (unit of angle)
%	Percentage
°C	Degree Centigrade
°F	Degree Fahrenheit
bar	Bar (unit of barometric pressure)
cm	Centimeter
deg	Degree (unit of angle)
ft	Foot
ft/s	Foot per Second
ft/s ²	Foot per Square Second
ft ²	Square Foot
ft ³	Cubic Foot
in	Inch
K	Kelvin
kg	Kilogram
kg/l	Kilogram per Liter
km/h	Kilometer per Hour
kt	Knot
kVA	Kilovolt Ampere
l	Liter
lb	Pound
lbf	Pounds Force
L/Min	Litre/Minute
m	Meter
m/s	Meter per Second
m ²	Square Meter
m ³	Cubic Meter
min	Minimum
mm	Millimeter
MN/m ³	Mega Newton per Cubic Meter
MPa	Mega Pascal
MPH	Meter/Hour
nm	Nautical Mile



**Aircraft Characteristics for Airport
Planning**

pci	Pound per Cubic Inch
psi	Pound per Square Inch
t	Ton
US gal	United States Gallon
qt	Quart

Intentionally left blank

Introduction

1. General

C919 Aircraft Characteristics for Airport Planning (ACAP) is issued to provide essential characteristics of C919 Aircraft and necessary data which are needed for airport operators and airlines for accomplishment of aircraft facilities planning.

ACAP is helpful for aircraft operators to accomplish airport facilities planning in a short time according to aircraft basic data, performance, ground maneuvering and servicing arrangement provided in this manual.

This manual comprises 8 chapters:

- A. Chapter 1: Scope and Introduction
- B. Chapter 2: Aircraft Description
- C. Chapter 3: Aircraft Performance
- D. Chapter 4: Ground Maneuvering
- E. Chapter 5: Terminal Servicing
- F. Chapter 6: Operating Conditions
- G. Chapter 7: Pavement Data

2. Revision Marks

On the left side of the manual page, a black vertical bar in the margin identifies the modified part. Refer to the revision highlights for the detailed revision reason.

Intentionally left blank

Chapter 01

Scope and Introduction

Intentionally left blank

contents

<u>Document title</u>	<u>Data module code</u>	<u>Number of pages</u>	<u>Applicable to</u>
01 Scope and Introduction			
Scope	C919-A-19-20-01-01A-01BA-A	1	ALL
Introduction	C919-A-19-20-01-02A-01BA-A	1	ALL
A Brief Description of the Aircraft	C919-A-19-20-01-03A-01BA-A	1	ALL

Intentionally left blank

Scope - General introduction

The C919 Aircraft Characteristics for Airport Planning manual is issued for the C919 STD and C919 ER aircraft to provide the aircraft characteristic data for airport operators and airlines for accomplishment of aircraft facilities planning.

Since operational practices vary among scheduled flights, specific data should be coordinated with the using airlines prior to application. Commercial Aircraft Corporation of China, Ltd. (COMAC) should be contacted for any additional information required.

Intentionally left blank

Introduction - General introduction

This manual comprises 7 chapters with a Table of Contents at the beginning of the manual.

Chapter 1 Scope and Introduction

Chapter 2 Aircraft Description

This chapter contains general dimensionals and other basic (family) aircraft data of C919 aircraft.

It covers:

- General Characteristics, General Dimensions and Ground Clearances,
- Passenger and Cargo Compartments Arrangement, and Door Clearances.

Chapter 3 Aircraft Performance

This chapter provides the aircraft performance parameters.

It covers:

- Payload/Range,
- Takeoff Runway and Landing Field Length Requirements,
- Landing Reference Speed.

Chapter 4 Ground Maneuvering

This chapter provides the aircraft turning capability and maneuvering characteristics on the ground.

It covers:

- Turning Radii and Visibility from the Cockpit,
- Runway and Taxiway Turn Path, and Runway Holding Bay.

Chapter 5 Terminal Servicing

This chapter provides information for ground handling and servicing setting and arrangement during ground servicing.

It covers:

- Locations and Connections of Ground Servicing Equipment,
- Engine Starting Pneumatic, Ground Air-Conditioning and Preconditioned Airflow Requirements.

Chapter 6 Operating Conditions

This chapter provides information on engines data and engines influence on ambience.

It covers:

- Engine and APU Exhaust Velocities and Temperatures,
- Airport and Community Noise,
- Danger Areas of the Engines.

Chapter 7 Pavement Data

This chapter provides the pavement data and additional pavement diagrams helpful for airport planning.

It covers:

Aircraft Characteristics for Airport Planning

- Landing Gear Footprint and Aircraft Identification,
- Maximum Pavement Load and Landing Gear Loading on Pavement,
- Flexible and Rigid Pavement Requirements, and Flexible and Rigid Pavement LCN Conversion,
- ACN/PCN Reporting System - Flexible and Rigid Pavements.

A Brief Description of the Aircraft - General introduction

C919 is an advanced trunk line aircraft of medium or short range, powered by turbofan engines.

The aircraft uses a conventional aerodynamic layout type, six seats for each row, a fuselage in the shape of multiple circular plane sections, supercritical sweptback low wings, normal tail, two high bypass ratio power plants mounted below left and right wings, tricycle retractable landing gear.

C919 is equipped with two LEAP-1C engines. This engine will incorporate the most advanced technologies to provide the lowest fuel consumption and environmental impact.

The cockpit is designed for a two-member crew. The avionics system features bus technology and LCD panel with integrated display capability. The flight control system is an electrical system controlled through electrical signals and actuated by hydraulic pressure or electro-mechanics, with international advanced technology. Supercritical wings with larger sweepback angle and integrated winglets are used to obtain a higher cruise lift-drag ratio, so as to reduce cruise drag and improve operation economy.

C919 is a single aisle aircraft. The cabin layout has three types: mixed type with 158 or 164 seats, full economy type with 168 seats and high density type with 174 seats. To meet the requirements of different regions and different route structures for aircraft, the aircraft has Standard Range Version (STD) and Extended Range Version (ER).

Intentionally left blank

Chapter 02

Aircraft Description

Intentionally left blank

contents

<u>Document title</u>	<u>Data module code</u>	<u>Number of pages</u>	<u>Applicable to</u>
02 Aircraft Description			
General Aircraft Characteristics	C919-A-19-20-02-01A-04AA-A	1	ALL
General Aircraft Dimensions	C919-A-19-20-02-02A-04AA-A	1	ALL
Ground Clearances	C919-A-19-20-02-03A-04AA-A	1	ALL
Interior Arrangements	C919-A-19-20-02-04A-04AA-A	1	ALL
Passenger Compartment Cross- Section	C919-A-19-20-02-05A-04AA-A	1	ALL
Lower Deck Compartments	C919-A-19-20-02-06A-04AA-A	1	ALL
Door Clearances	C919-A-19-20-02-07A-04AA-A	1	ALL
Evacuation Slide	C919-A-19-20-02-08A-04AA-A	1	ALL
Landing Gear	C919-A-19-20-02-09A-04AA-A	1	ALL
Exterior Lighting	C919-A-19-20-02-10A-04AA-A	1	ALL
Antenna Locations	C919-A-19-20-02-11A-04AA-A	1	ALL
Power Plant	C919-A-19-20-02-12A-04AA-A	1	ALL
Leveling/Weighting	C919-A-19-20-02-13A-04AA-A	1	ALL
Jacking	C919-A-19-20-02-14A-04AA-A	1	ALL

Intentionally left blank



General Aircraft Characteristics

Maximum Design Taxi Weight (MTW):

Maximum weight for ground maneuver as limited by aircraft strength and airworthiness requirements. (It includes weight of taxi and run-up fuel.)

Maximum Design Landing Weight (MLW):

Maximum weight for landing as limited by aircraft strength and airworthiness requirements.

Maximum Design Takeoff Weight (MTOW):

Maximum weight for takeoff as limited by aircraft strength and airworthiness requirements. (This is the maximum weight at start of the takeoff run.)

Operating Empty Weight (OEW):

Weight of structure, powerplant, furnishing systems, unusable fuel and other unusable propulsion agents, and other items of equipment that are considered an integral part of a particular aircraft configuration. Also included are certain standard items, personnel, equipment, and supplies necessary for full operations, excluding usable fuel and payload.

Maximum Design Zero Fuel Weight (MZFW):

Maximum weight allowed before usable fuel and other specified usable agents must be loaded in defined sections of the aircraft as limited by strength and airworthiness requirements.

Maximum Payload:

Maximum design zero fuel weight minus operating empty weight.

Maximum Seating Capacity:

The maximum number of passengers specifically certificated or anticipated for certification.

Avionics Compartment Volume:

Theoretical volume of the space region surrounded by the boundary of E-E bay.

Cockpit Volume:

Theoretical volume of the space region surrounded by the boundary of Cockpit.

Maximum Cargo Volume:

The maximum space available for cargo.

Usable Fuel:

Fuel available for aircraft propulsion.

Table 1 General Aircraft Characteristics Data

		C919 STD	C919 ER
Maximum Design Taxi Weight (MTW)	lb	166 448	174 826
	kg	75 500	79 300
Maximum Design Landing Weight (MLW)	lb	149 473	149 473
	kg	67 800	67 800

**Aircraft Characteristics for Airport
Planning**

Maximum Design Takeoff Weight (MTOW)	lb	165 567	173 944
	kg	75 100	78 900
Operating Empty Weight (OEW)	lb	100 751	100 751
	kg	45 700	45 700
Maximum Design Zero Fuel Weight (MZFW)	lb	142 418	142 418
	kg	64 600	64 600
Maximum Payload	lb	41 667	41 667
	kg	18 900	18 900
Maximum Seating Capacity	Mixed type	158	158
	All Economy	168	168
	High Intensity	174	174
Maximum Cargo Volume	ft ³	1 596.2	1 596.2
	m ³	45.2	45.2
Usable Fuel	ft ³	879.9	879.9
	m ³	24.9	24.9
	L	24 917	24 917

General Aircraft Dimensions

Applicable to : ALL

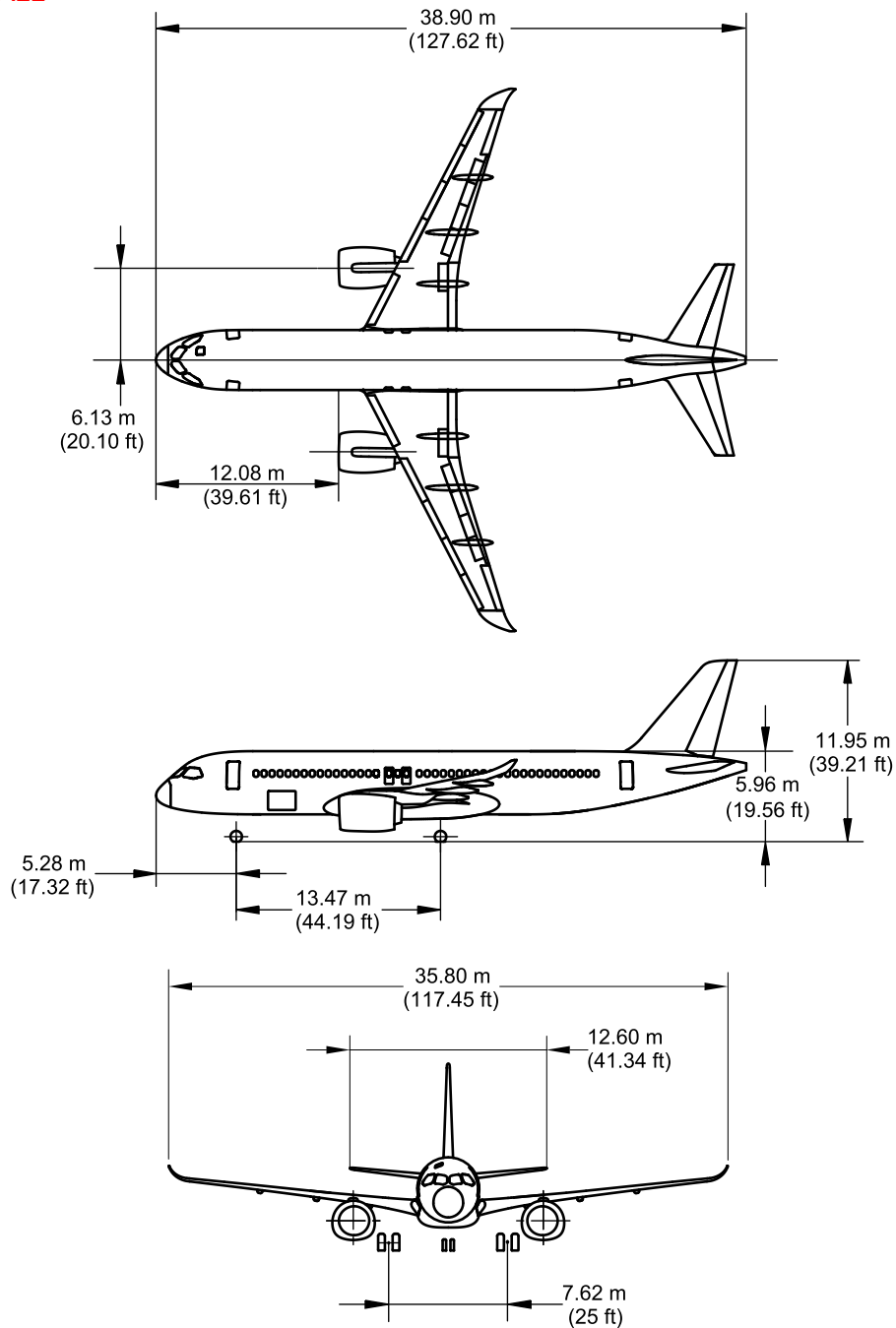

ICN-C919-A-192002-A-SVV19-10709-A-006-01

Figure 1 General Aircraft Dimensions (Sheet 1 of 1)

Intentionally left blank



Ground Clearances

Aircraft Characteristics for Airport Planning

Applicable to : ALL

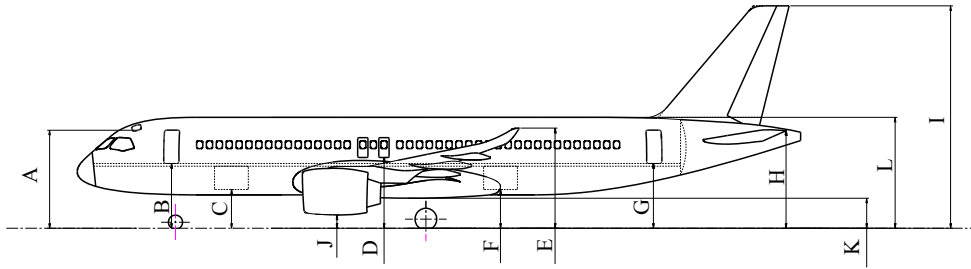

ICN-C919-A-192002-A-SVV19-10715-A-003-01

Figure 1 Ground Clearances (Sheet 1 of 1)

Table 1 Ground Clearances-STD (15°C)

	Description	OEW				MTW			
		FWD CG		AFT CG		FWD CG		AFT CG	
		M	FT	M	FT	M	FT	M	FT
A	Cockpit Emergency Exit	5.23	17.17	5.40	17.72	5.19	17.02	5.30	17.38
B	FWD Entry Door / FWD Service Door	3.46	11.35	3.60	11.82	3.41	11.18	3.50	11.49
C	FWD Cargo Door	2.09	6.86	2.19	7.20	2.03	6.65	2.09	6.87
D	Emergency Door	3.76	12.35	3.77	12.38	3.67	12.04	3.68	12.06
E	Wingtip	5.49	18.01	5.41	17.76	5.37	17.62	5.32	17.45
F	AFT Cargo Door	2.21	7.26	2.15	7.04	2.10	6.88	2.05	6.74
G	AFT Entry Door / AFT Service Door	3.68	12.08	3.52	11.55	3.54	11.61	3.43	11.25
H	Stabilizer	5.51	18.09	5.27	17.28	5.34	17.53	5.18	16.99
I	Vertical Tail	12.21	40.07	11.97	39.26	12.04	39.51	11.88	38.97
J	Engine	0.73	2.40	0.77	2.52	0.65	2.13	0.67	2.20
K	Bottom of Fuselage	1.54	5.06	1.56	5.12	1.45	4.77	1.46	4.80
L	Top of Fuselage	6.14	20.14	6.08	19.95	6.00	19.69	5.98	19.62



Table 2 Ground Clearances-ER (15°C)

	Description	OEW				MTW			
		FWD CG		AFT CG		FWD CG		AFT CG	
		M	FT	M	FT	M	FT	M	FT
A	Cockpit Emergency Exit	5.23	17.16	5.40	17.71	5.20	17.05	5.27	17.29
B	FWD Entry Door / FWD Service Door	3.46	11.35	3.60	11.82	3.42	11.21	3.48	11.41
C	FWD Cargo Door	2.09	6.87	2.20	7.20	2.03	6.66	2.08	6.81
D	Emergency Door	3.77	12.37	3.78	12.40	3.67	12.03	3.67	12.04
E	Wingtip	5.50	18.05	5.42	17.80	5.36	17.58	5.32	17.47
F	AFT Cargo Door	2.22	7.30	2.16	7.08	2.09	6.84	2.06	6.75
G	AFT Entry Door / AFT Service Door	3.70	12.14	3.54	11.60	3.52	11.55	3.45	11.31
H	Stabilizer	5.54	18.16	5.29	17.35	5.32	17.44	5.21	17.08
I	Vertical Tail	12.24	40.14	11.99	39.33	12.02	39.42	11.91	39.06
J	Engine	0.74	2.42	0.77	2.54	0.65	2.12	0.66	2.17
K	Bottom of Fuselage	1.55	5.08	1.57	5.14	1.45	4.76	1.46	4.78
L	Top of Fuselage	6.15	20.19	6.08	19.95	5.99	19.64	5.96	19.54

Table 3 Ground Clearances at Jacked Status

	Description	M	FT
A	Cockpit Emergency Exit	5.56	18.24
B	FWD Entry Door / FWD Service Door	3.79	12.44
C	FWD Cargo Door	2.43	7.98
D	Emergency Door	4.12	13.53
E	Wingtip	5.87	19.25
F	AFT Cargo Door	2.59	8.49
G	AFT Entry Door / AFT Service Door	4.08	13.39
H	Stabilizer	5.93	19.45
I	Vertical Tail	12.63	41.43
J	Engine	1.09	3.57

**Aircraft Characteristics for Airport
Planning**

	Description	M	FT
K	Bottom of Fuselage	1.90	6.23
L	Top of Fuselage	6.53	21.42

NOTE: Landing Gear Fully-Extended Status on the Jacks.



Applicable to : ALL

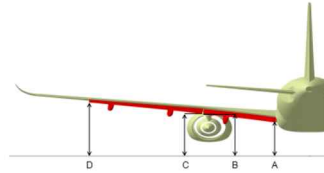

ICN-C919-A-192002-A-SVV19-65035-A-001-01

Figure 2 Ground Clearances of Flap Fully Extended Status of Each Flap (Sheet 1 of 1)

Table 4 Definition of Ground Clearances of each Flap

Description	Serial Number	Name of size
FLAP1 IN	A	Ground clearances of Flap 1 inboard extended status
FLAP1 OUT	B	Ground clearances of Flap 1 outboard extended status
FLAP2 IN	C	Ground clearances of Flap 2 inboard extended status
FLAP2 OUT	D	Ground clearances of Flap 2 outboard extended status

Premise Condition				Ground Clearances of each Flap (mm)											
Model	Temperature (°)	Weight (kg)	Center of Gravity (%)	FLA P1 IN	FLA P1 OUT	FLA P2 IN	FLA P2 OUT	FLA P1 IN	FLA P1 OUT	FLA P2 IN	FLA P2 OUT	FLA P1 IN	FLA P1 OUT	FLA P2 IN	FLA P2 OUT
				Detent 0				Detent 2				Detent FULL			
STD	15	45700	12	2714	3424	3433	4243	2356	3003	3043	4000	6004	2774	2794	3864
		45700	35.14	2686	3394	3403	4194	2324	2970	3009	3947	5973	2741	2761	3811
		75500	18.3	2608	3317	3327	4128	2249	2895	2935	3883	5897	2666	2686	3747
		75500	38	2588	3296	3305	4093	2226	2871	2911	3845	5875	2643	2663	3709
	0	45700	12	2694	3404	3414	4223	2336	2983	3024	3980	5985	2754	2774	3844
		45700	35.14	2667	3375	3385	4176	2306	2951	2991	3929	5955	2723	2743	3793
75500		18.3	2591	3300	3310	4111	2232	2878	2918	3865	5880	2649	2669	3730	

Applicable to: ALL



Aircraft Characteristics for Airport Planning

Premise Condition				Ground Clearances of each Flap (mm)											
Model	Temperature (°)	Weight (kg)	Center of Gravity (%)	FLA P1 IN	FLA P1 OUT	FLA P2 IN	FLA P2 OUT	FLA P1 IN	FLA P1 OUT	FLA P2 IN	FLA P2 OUT	FLA P1 IN	FLA P1 OUT	FLA P2 IN	FLA P2 OUT
				Detent 0				Detent 2				Detent FULL			
	-10	7550	38	2572	3279	3289	4076	2210	2855	2894	3828	5858	2627	2646	3693
		4570	12	2681	3391	3401	4209	2323	2970	3010	3966	5972	2741	2761	3830
		4570	35.14	2655	3363	3373	4164	2294	2939	2979	3917	5942	2711	2731	3781
		7550	18.3	2580	3289	3298	4099	2220	2867	2907	3854	5869	2638	2658	3718
		7550	38	2561	3268	3278	4065	2199	2844	2883	3817	5847	2615	2635	3682
	-20	4570	12	2668	3378	3388	4196	2310	2957	2997	3952	5959	2728	2748	3816
		4570	35.14	2643	3351	3360	4152	2282	2927	2967	3905	5930	2699	2718	3769
		7550	18.3	2569	3278	3287	4087	2209	2855	2895	3842	5857	2626	2646	3706
		7550	38	2549	3257	3266	4054	2187	2832	2872	3806	5836	2604	2624	3670
	-30	4570	12	2655	3365	3375	4182	2297	2944	2984	3938	5945	2715	2735	3803
		4570	35.14	2631	3339	3348	4140	2269	2915	2955	3893	5918	2686	2706	3757
		7550	18.3	2557	3266	3275	4075	2197	2844	2883	3830	5846	2615	2635	3694
		7550	38	2538	3246	3255	4042	2176	2821	2861	3794	5825	2593	2612	3658
	-40	4570	12	2643	3352	3362	4169	2284	2931	2971	3925	5933	2702	2722	3789
		4570	35.14	2619	3327	3336	4128	2257	2903	2943	3881	5906	2674	2694	3745
		7550	18.3	2546	3255	3264	4064	2186	2832	2872	3818	5835	2604	2623	3683
		7550	38	2527	3235	3244	4031	2165	2810	2849	3783	5813	2582	2601	3647



**Aircraft Characteristics for Airport
Planning**

Premise Condition				Ground Clearances of each Flap (mm)											
Model	Temperature (°)	Weight (kg)	Center of Gravity (%)	FLA P1 IN	FLA P1 OUT	FLA P2 IN	FLA P2 OUT	FLA P1 IN	FLA P1 OUT	FLA P2 IN	FLA P2 OUT	FLA P1 IN	FLA P1 OUT	FLA P2 IN	FLA P2 OUT
				Detent 0				Detent 2				Detent FULL			
ER	15	45700	12	2723	3433	3443	4254	2366	3013	3053	4011	6014	2784	2804	3875
		45700	35.14	2694	3403	3412	4204	2333	2979	3019	3957	5982	2750	2770	3822
		79300	21	2602	3311	3321	4121	2243	2889	2929	3876	5891	2660	2680	3740
		79300	36	2587	3295	3304	4094	2225	2871	2910	3847	5874	2642	2662	3711
	0	45700	12	2703	3413	3423	4233	2346	2993	3033	3990	5994	2764	2784	3854
		45700	35.14	2676	3384	3393	4186	2315	2960	3000	3939	5963	2732	2751	3803
		79300	21	2585	3294	3303	4103	2225	2872	2911	3858	5874	2643	2663	3722
		79300	36	2570	3278	3287	4077	2209	2854	2894	3830	5857	2626	2645	3694
	-10	45700	12	2690	3400	3409	4219	2332	2979	3019	3976	5981	2750	2770	3840
		45700	35.14	2663	3371	3381	4173	2302	2948	2987	3926	5951	2719	2739	3791
		79300	21	2574	3283	3292	4091	2214	2860	2900	3846	5862	2631	2651	3710
		79300	36	2559	3267	3276	4066	2197	2843	2882	3818	5846	2614	2634	3683
	-20	45700	12	2677	3387	3396	4206	2319	2966	3006	3962	5967	2737	2757	3826
		45700	35.14	2651	3359	3368	4161	2290	2935	2975	3914	5938	2707	2726	3778
		79300	21	2562	3271	3280	4079	2202	2848	2888	3834	5851	2620	2639	3698
		79300	36	2547	3255	3265	4054	2186	2831	2871	3806	5834	2603	2622	3671
	-30	45700	12	2663	3373	3383	4191	2305	2952	2992	3948	5954	2723	2743	3812

**Aircraft Characteristics for Airport
Planning**

Premise Condition				Ground Clearances of each Flap (mm)											
Model	Temperature (°)	Weight (kg)	Center of Gravity (%)	FLA P1 IN	FLA P1 OUT	FLA P2 IN	FLA P2 OUT	FLA P1 IN	FLA P1 OUT	FLA P2 IN	FLA P2 OUT	FLA P1 IN	FLA P1 OUT	FLA P2 IN	FLA P2 OUT
				Detent 0				Detent 2				Detent FULL			
		45700	35.14	2638	3346	3356	4148	2277	2923	2962	3902	5926	2694	2714	3766
		79300	21	2550	3259	3269	4067	2190	2837	2876	3821	5839	2608	2628	3686
		79300	36	2536	3244	3253	4042	2174	2819	2859	3794	5823	2591	2611	3659
	-40	45700	12	2650	3360	3369	4178	2292	2939	2979	3934	5940	2710	2730	3798
		45700	35.14	2626	3334	3343	4136	2265	2910	2950	3889	5913	2682	2701	3754
		79300	21	2539	3248	3257	4056	2179	2825	2865	3810	5828	2597	2616	3674
		79300	36	2525	3232	3242	4031	2163	2808	2848	3783	5811	2580	2599	3647

Applicable to : ALL

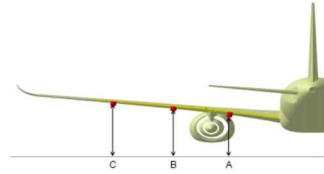

ICN-C919-A-192002-A-SVV19-65036-A-001-01

Figure 3 Ground Clearances of Flap Track Fairing (Sheet 1 of 1)

Table 5 Definition of Ground Clearances of Flap Track Fairing

Description	Serial Number	Name of size
FAIRING1	A	Ground clearances of inboard flap track fairing 1
FAIRING2	B	Ground clearances of outboard flap track fairing 2
FAIRING3	C	Ground clearances of outboard flap track fairing 3

Table 6 Ground Clearances of Flap Track Fairing

Premise Condition				Ground Clearances of Flap Track Fairing (mm)								
Model	Temperature (°)	Weight (kg)	Center of Gravity (%)	FAIRING1	FAIRING2	FAIRING3	FAIRING1	FAIRING2	FAIRING3	FAIRING1	FAIRING2	FAIRING3
				Detent 0			Detent 2			Detent FULL		
STD	15	45700	12	2897	3402	3822	2214	2839	3332	2214	2839	3332
		45700	35.14	2862	3361	3770	2180	2799	3280	2180	2799	3280
		75500	18.3	2789	3290	3705	2106	2728	3216	2106	2728	3216
		75500	38	2763	3261	3668	2082	2699	3179	2082	2699	3179
	0	45700	12	2878	3382	3801	2195	2819	3311	2195	2819	3311
		45700	35.14	2844	3343	3752	2162	2781	3263	2162	2781	3263
		75500	18.3	2771	3273	3688	2089	2711	3198	2089	2711	3198
		75500	38	2747	3244	3651	2066	2683	3162	2066	2683	3162
	-10	45700	12	2864	3369	3788	2181	2806	3298	2181	2806	3298
		45700	35.14	2832	3331	3740	2150	2769	3251	2150	2769	3251
		75500	18.3	2760	3262	3676	2078	2699	3186	2078	2699	3186
		75500	38	2736	3233	3640	2054	2672	3151	2054	2672	3151
	-20	45700	12	2851	3355	3774	2168	2792	3284	2168	2792	3284

Applicable to: ALL



Aircraft Characteristics for Airport Planning

Premise Condition				Ground Clearances of Flap Track Fairing (mm)								
Model	Temperature (°)	Weight (kg)	Center of Gravity (%)	FAIRI NG1	FAIRI NG2	FAIRI NG3	FAIRI NG1	FAIRI NG2	FAIRI NG3	FAIRI NG1	FAIRI NG2	FAIRI NG3
				Detent 0			Detent 2			Detent FULL		
		45700	35.14	2820	3319	3728	2138	2756	3239	2138	2756	3239
		75500	18.3	2748	3250	3664	2066	2687	3174	2066	2687	3174
		75500	38	2724	3222	3629	2043	2660	3140	2043	2660	3140
	-30	45700	12	2838	3342	3760	2155	2779	3270	2155	2779	3270
		45700	35.14	2807	3306	3716	2126	2744	3226	2126	2744	3226
		75500	18.3	2737	3238	3652	2054	2676	3162	2054	2676	3162
		75500	38	2713	3210	3617	2032	2649	3128	2032	2649	3128
	-40	45700	12	2825	3329	3747	2142	2766	3257	2142	2766	3257
		45700	35.14	2795	3294	3704	2114	2732	3215	2114	2732	3215
		75500	18.3	2726	3227	3641	2043	2664	3151	2043	2664	3151
		75500	38	2702	3199	3606	2021	2637	3117	2021	2637	3117
	ER	15	45700	12	2907	3412	3833	2224	2849	3343	2224	2849
45700			35.14	2871	3370	3780	2190	2808	3291	2190	2808	3291
79300			21	2782	3284	3698	2100	2721	3208	2100	2721	3208
79300			36	2763	3262	3670	2082	2700	3181	2082	2700	3181
0		45700	12	2887	3392	3812	2204	2829	3322	2204	2829	3322
		45700	35.14	2853	3352	3762	2171	2790	3272	2171	2790	3272
		79300	21	2765	3266	3680	2083	2704	3190	2083	2704	3190
		79300	36	2746	3245	3653	2065	2683	3164	2065	2683	3164
-10		45700	12	2874	3378	3798	2191	2815	3308	2191	2815	3308
		45700	35.14	2840	3339	3749	2158	2777	3260	2158	2777	3260
		79300	21	2753	3254	3668	2071	2692	3179	2071	2692	3179
		79300	36	2735	3233	3641	2053	2671	3152	2053	2671	3152
-20		45700	12	2860	3364	3784	2177	2801	3294	2177	2801	3294
		45700	35.14	2828	3327	3737	2146	2765	3248	2146	2765	3248
		79300	21	2741	3243	3656	2059	2680	3166	2059	2680	3166
		79300	36	2723	3221	3629	2042	2659	3140	2042	2659	3140
-30		45700	12	2846	3351	3770	2163	2788	3280	2163	2788	3280
		45700	35.14	2815	3314	3724	2133	2752	3235	2133	2752	3235
		79300	21	2730	3231	3644	2047	2668	3154	2047	2668	3154
		79300	36	2711	3210	3617	2030	2648	3128	2030	2648	3128
-40	45700	12	2833	3337	3756	2150	2774	3266	2150	2774	3266	



**Aircraft Characteristics for Airport
Planning**

Premise Condition				Ground Clearances of Flap Track Fairing (mm)								
Model	Temperature (°)	Weight (kg)	Center of Gravity (%)	FAIRI NG1	FAIRI NG2	FAIRI NG3	FAIRI NG1	FAIRI NG2	FAIRI NG3	FAIRI NG1	FAIRI NG2	FAIRI NG3
				Detent 0			Detent 2			Detent FULL		
		45700	35.14	2803	3302	3712	2121	2740	3223	2121	2740	3223
		79300	21	2718	3219	3632	2036	2657	3143	2036	2657	3143
		79300	36	2700	3198	3606	2019	2636	3117	2019	2636	3117

Applicable to : ALL

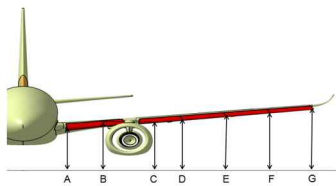

ICN-C919-A-192002-A-SVV19-65037-A-001-01

Figure 4 Ground Clearances of Slat Extended Status (Sheet 1 of 1)

Table 7 Definition of Ground Clearances of Slat Extended Status

Description	Serial Number	Name of size
SLOF1 IN	A	Ground clearances of Slat 1 inboard extended status
SLOF1 OUT	B	Ground clearances of Slat1 outboard extended status
SLOF2 IN	C	Ground clearances of Slat 2 inboard extended status
SLOF2 OUT	D	Ground clearances of Slat 2 outboard extended status
SLOF3 IN	D	Ground clearances of Slat 3 inboard extended status
SLOF3 OUT	E	Ground clearances of Slat 3 outboard extended status
SLOF4 IN	E	Ground clearances of Slat 4 inboard extended status
SLOF4 OUT	F	Ground clearances of Slat 4 outboard extended status
SLOF5 IN	F	Ground clearances of Slat 5 inboard extended status
SLOF5 OUT	G	Ground clearances of Slat 5 outboard extended status



Table 8 Ground Clearances of Slat Extended Status

Premise Condition				Ground Clearances at Detent FULL of Slat (mm)									
Mode I	Temperature (°)	Weight (kg)	Center of Gravity (%)	SLO F1 IN	SLO F1 OUT	SLO F2 IN	SLO F2 OUT	SLO F3 IN	SLO F3 OUT	SLO F4 IN	SLO F4 OUT	SLO F5 IN	SLO F5 OUT
				Detent FULL									
STD	15	45700	12	2743	3170	3198	3482	3483	3764	3765	4046	4047	4332
		45700	35.14	2776	3187	3209	3480	3481	3749	3750	4019	4020	4292
		75500	18.3	2666	3085	3110	3388	3389	3665	3666	3941	3942	4221
		75500	38	2691	3098	3119	3388	3389	3654	3655	3921	3922	4192
	0	45700	12	2726	3153	3180	3463	3465	3745	3746	4027	4028	4312
		45700	35.14	2757	3168	3190	3461	3462	3731	3732	4000	4001	4273
		75500	18.3	2651	3070	3095	3372	3373	3648	3649	3924	3925	4204
		75500	38	2674	3081	3102	3371	3372	3638	3639	3905	3906	4175
	-10	45700	12	2715	3141	3168	3451	3452	3732	3734	4014	4015	4299
		45700	35.14	2744	3155	3177	3449	3450	3718	3719	3988	3989	4261
		75500	18.3	2641	3059	3084	3361	3363	3637	3638	3913	3914	4192
		75500	38	2663	3070	3091	3360	3361	3627	3628	3894	3895	4164
	-20	45700	12	2704	3129	3156	3439	3440	3720	3721	4001	4002	4286
		45700	35.14	2731	3142	3165	3436	3437	3706	3707	3976	3977	4249
		75500	18.3	2630	3049	3073	3351	3352	3626	3627	3901	3902	4180
		75500	38	2652	3059	3081	3349	3350	3616	3617	3883	3884	4153



Aircraft Characteristics for Airport Planning

Premise Condition				Ground Clearances at Detent FULL of Slat (mm)									
Mode I	Temperature (°)	Weight (kg)	Center of Gravity (%)	SLO F1 IN	SLO F1 OUT	SLO F2 IN	SLO F2 OUT	SLO F3 IN	SLO F3 OUT	SLO F4 IN	SLO F4 OUT	SLO F5 IN	SLO F5 OUT
				Detent FULL									
	-30	45700	12	2693	3118	3144	3427	3428	3707	3708	3988	3989	4272
		45700	35.14	2719	3130	3152	3424	3425	3694	3695	3964	3965	4237
		75500	18.3	2620	3038	3063	3339	3341	3615	3616	3890	3891	4169
		75500	38	2642	3048	3070	3338	3339	3604	3606	3871	3872	4141
	-40	45700	12	2682	3106	3133	3415	3416	3695	3696	3975	3976	4259
		45700	35.14	2706	3117	3140	3412	3413	3681	3683	3952	3953	4225
		75500	18.3	2610	3027	3052	3329	3330	3604	3605	3879	3880	4157
		75500	38	2631	3038	3059	3327	3328	3593	3595	3860	3861	4130
ER	15	45700	12	2749	3177	3205	3489	3491	3772	3774	4056	4057	4343
		45700	35.14	2781	3193	3215	3487	3488	3757	3758	4027	4029	4301
		79300	21	2663	3082	3106	3384	3385	3659	3660	3935	3936	4214
		79300	36	2681	3090	3112	3383	3384	3651	3652	3920	3921	4192
	0	45700	12	2732	3159	3186	3471	3472	3753	3754	4036	4037	4322
		45700	35.14	2762	3173	3196	3468	3469	3738	3739	4009	4010	4283
		79300	21	2648	3066	3091	3368	3369	3643	3644	3918	3919	4197
		79300	36	2665	3074	3096	3366	3367	3635	3636	3903	3904	4175
	-10	45700	12	2720	3147	3174	3458	3459	3740	3741	4022	4024	4308



**Aircraft Characteristics for Airport
Planning**

Premise Condition				Ground Clearances at Detent FULL of Slat (mm)									
Mode I	Temp eratu re (°)	Weig ht (k g)	Cent er of Gravi ty (%)	SLO F1 IN	SLO F1 OUT	SLO F2 IN	SLO F2 OUT	SLO F3 IN	SLO F3 OUT	SLO F4 IN	SLO F4 OUT	SLO F5 IN	SLO F5 OUT
				Detent FULL									
		4570 0	35.14	2749	3160	3183	3455	3456	3726	3727	3996	3997	4270
		7930 0	21	2638	3056	3080	3357	3358	3631	3633	3906	3908	4185
		7930 0	36	2654	3063	3085	3355	3356	3623	3625	3892	3893	4164
	-20	4570 0	12	2709	3135	3162	3446	3447	3727	3728	4009	4010	4295
		4570 0	35.14	2736	3148	3170	3443	3444	3713	3714	3984	3985	4258
		7930 0	21	2628	3045	3069	3346	3347	3620	3621	3895	3896	4173
		7930 0	36	2644	3052	3074	3344	3345	3612	3613	3880	3882	4152
	-30	4570 0	12	2697	3123	3150	3433	3434	3714	3716	3996	3997	4281
		4570 0	35.14	2723	3135	3158	3430	3431	3700	3701	3971	3972	4245
		7930 0	21	2617	3034	3058	3334	3336	3609	3610	3883	3884	4161
		7930 0	36	2633	3041	3063	3333	3334	3601	3602	3869	3870	4140
	-40	4570 0	12	2686	3111	3138	3421	3422	3702	3703	3983	3984	4267
4570 0		35.14	2710	3122	3145	3417	3419	3688	3689	3959	3960	4233	
7930 0		21	2607	3023	3048	3324	3325	3598	3599	3872	3873	4150	
7930 0		36	2623	3031	3053	3322	3323	3590	3591	3858	3859	4129	

Applicable to : ALL

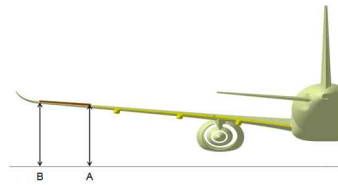

ICN-C919-A-192002-A-SVV19-65038-A-001-01

Figure 5 Ground Clearances at Aileron Raise Status (Sheet 1 of 1)

Applicable to : ALL

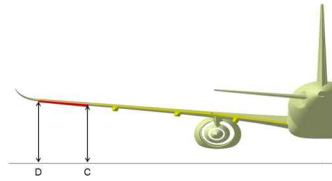

ICN-C919-A-192002-A-SVV19-65039-A-001-01

Figure 6 Ground Clearances at Aileron Down Status (Sheet 1 of 1)

Table 9 Definition of Ground Clearances of Aileron Deflection

Description	Serial Number	Name of size
AILERON IN	A	Ground Clearances at inboard Aileron Raise Status
AILERON OUT	B	Ground Clearances at outboard Aileron Raise Status
AILERON IN	C	Ground Clearances at inboard Aileron Down Status
AILERON OUT	D	Ground Clearances at outboard Aileron Down Status

Table 10 Ground Clearances of Aileron Deflection

Premise Condition				Ground Clearances of Aileron Deflection (mm)			
Model	Temperature (°)	Weight (kg)	Center of Gravity (%)	AILERON IN	AILERON OUT	AILERON IN	AILERON OUT
				UP		DOWN	
STD	15	45700	12	4490	4759	4053	4442
		45700	35.14	4440	4700	4004	4383
		75500	18.3	4374	4639	3938	4323
		75500	38	4338	4597	3902	4280
	0	45700	12	4469	4738	4033	4421
		45700	35.14	4422	4682	3986	4366
		75500	18.3	4357	4622	3920	4305
		75500	38	4322	4581	3886	4264
	-10	45700	12	4456	4724	4019	4407
		45700	35.14	4410	4670	3974	4354
		75500	18.3	4345	4610	3909	4293
		75500	38	4311	4569	3875	4253
-20	45700	12	4442	4710	4006	4393	

Applicable to: ALL

02-03

Issue 001, 2022-10-20

Page 17 of 22



Aircraft Characteristics for Airport Planning

Premise Condition				Ground Clearances of Aileron Deflection (mm)			
Model	Temperature (°)	Weight (kg)	Center of Gravity (%)	AILERON IN	AILERON OUT	AILERON IN	AILERON OUT
				UP		DOWN	
		45700	35.14	4398	4659	3962	4342
		75500	18.3	4333	4598	3897	4281
		75500	38	4299	4558	3863	4241
	-30	45700	12	4428	4696	3992	4380
		45700	35.14	4386	4646	3950	4330
		75500	18.3	4321	4585	3885	4269
		75500	38	4288	4546	3852	4230
	-40	45700	12	4415	4683	3979	4366
		45700	35.14	4374	4635	3938	4318
		75500	18.3	4310	4574	3873	4257
		75500	38	4276	4535	3841	4218
	ER	15	45700	12	4501	4770	4064
45700			35.14	4450	4711	4014	4394
79300			21	4367	4632	3931	4315
79300			36	4340	4600	3904	4283
0		45700	12	4480	4749	4043	4432
		45700	35.14	4432	4692	3995	4376
		79300	21	4349	4613	3913	4297
		79300	36	4323	4583	3887	4266
-10		45700	12	4466	4735	4029	4418
		45700	35.14	4419	4680	3983	4364
		79300	21	4337	4601	3901	4285
		79300	36	4312	4571	3876	4255
-20		45700	12	4452	4721	4015	4404
		45700	35.14	4407	4668	3971	4351
		79300	21	4325	4589	3889	4272
		79300	36	4300	4559	3864	4243
-30		45700	12	4438	4706	4001	4389
		45700	35.14	4394	4655	3958	4339
		79300	21	4313	4577	3877	4260
		79300	36	4288	4547	3852	4231
-40		45700	12	4424	4692	3987	4375
		45700	35.14	4382	4643	3946	4327

Premise Condition				Ground Clearances of Aileron Deflection (mm)			
Model	Temperature (°)	Weight (kg)	Center of Gravity (%)	AILERON IN	AILERON OUT	AILERON IN	AILERON OUT
				UP		DOWN	
		79300	21	4302	4565	3865	4249
		79300	36	4276	4535	3840	4219

Applicable to : ALL

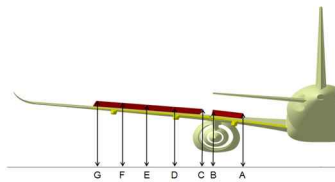

ICN-C919-A-192002-A-SVV19-65040-A-001-01

Figure 7 Ground Clearances at Spoiler Raise Status (Sheet 1 of 1)

Table 11 Definition of Ground Clearances at Spoiler Raise Status

Description	Serial Number	Name of size
SPOILER1 IN	A	Ground Clearances at inboard No.1 Spoiler Raise Status
SPOILER1 OUT	B	Ground Clearances at outboard No.1 Spoiler Raise Status
SPOILER2 IN	C	Ground Clearances at inboard No.2 Spoiler Raise Status
SPOILER2 OUT	D	Ground Clearances at outboard No.2 Spoiler Raise Status
SPOILER3 IN	D	Ground Clearances at inboard No.3 Spoiler Raise Status
SPOILER3 OUT	E	Ground Clearances at outboard No.3 Spoiler Raise Status
SPOILER4 IN	E	Ground Clearances at inboard No.4 Spoiler Raise Status
SPOILER4 OUT	F	Ground Clearances at outboard No.4 Spoiler Raise Status
SPOILER5 IN	F	Ground Clearances at inboard No.5 Spoiler Raise Status
SPOILER5 OUT	G	Ground Clearances at outboard No.5 Spoiler Raise Status

Applicable to: ALL

02-03

Issue 001, 2022-10-20

Page 19 of 22



Aircraft Characteristics for Airport Planning

Table 12 Definition of Ground Clearances at Spoiler Raise Status

Premise Condition				Ground Clearances at Spoiler Raise Status (mm)									
Mode I	Temperature (°)	Weight (kg)	Center of Gravity (%)	SPOILER1 IN	SPOILER1 OUT	SPOILER2 IN	SPOILER2 OUT	SPOILER3 IN	SPOILER3 OUT	SPOILER4 IN	SPOILER4 OUT	SPOILER5 IN	SPOILER5 OUT
				UP									
STD	15	45700	12	3799	4069	4135	4306	4307	4473	4474	4626	4627	4776
		45700	35.14	3778	4048	4113	4278	4279	4439	4440	4587	4588	4732
		75500	18.3	3696	3967	4032	4201	4201	4365	4366	4516	4516	4663
		75500	38	3682	3952	4017	4180	4181	4340	4341	4487	4488	4631
	0	45700	12	3779	4050	4116	4287	4288	4453	4454	4606	4607	4756
		45700	35.14	3759	4030	4095	4259	4260	4421	4422	4569	4570	4714
		75500	18.3	3680	3950	4016	4184	4185	4348	4349	4498	4499	4646
		75500	38	3665	3936	4000	4164	4165	4324	4325	4471	4472	4615
	-10	45700	12	3767	4037	4103	4274	4275	4440	4441	4593	4594	4743
		45700	35.14	3747	4018	4082	4247	4248	4409	4410	4557	4557	4702
		75500	18.3	3669	3939	4005	4172	4173	4336	4337	4487	4488	4634
		75500	38	3654	3925	3989	4153	4154	4313	4314	4460	4461	4604
	-20	45700	12	3754	4024	4090	4261	4262	4427	4428	4580	4581	4729
		45700	35.14	3735	4005	4070	4235	4236	4396	4397	4544	4545	4690
		75500	18.3	3657	3928	3993	4161	4162	4325	4326	4475	4476	4623
		75500	38	3643	3914	3978	4141	4142	4302	4302	4448	4449	4592



**Aircraft Characteristics for Airport
Planning**

Premise Condition				Ground Clearances at Spoiler Raise Status (mm)									
Mode I	Temp eratu re (°)	Weig ht (k g)	Cent er of Gravi ty (%)	SPOI LER1 IN	SPOI LER1 OUT	SPOI LER2 IN	SPOI LER2 OUT	SPOI LER3 IN	SPOI LER3 OUT	SPOI LER4 IN	SPOI LER4 OUT	SPOI LER5 IN	SPOI LER5 OUT
				UP									
	-30	4570 0	12	3741	4012	4078	4248	4249	4414	4415	4566	4567	4716
		4570 0	35.14	3722	3993	4058	4223	4224	4384	4385	4532	4533	4678
		7550 0	18.3	3646	3917	3982	4149	4150	4313	4314	4463	4464	4611
		7550 0	38	3632	3902	3966	4130	4131	4290	4291	4437	4438	4581
	-40	4570 0	12	3729	3999	4065	4235	4236	4401	4402	4553	4554	4703
		4570 0	35.14	3710	3981	4046	4211	4212	4372	4373	4520	4521	4666
		7550 0	18.3	3635	3906	3971	4138	4139	4302	4303	4452	4453	4600
		7550 0	38	3621	3891	3955	4119	4120	4279	4280	4426	4427	4570
ER	15	4570 0	12	3808	4078	4144	4316	4317	4483	4484	4636	4637	4787
		4570 0	35.14	3786	4057	4121	4286	4287	4448	4449	4596	4597	4742
		7930 0	21	3691	3961	4027	4194	4195	4358	4359	4509	4510	4656
		7930 0	36	3679	3950	4015	4179	4180	4340	4341	4488	4489	4632
	0	4570 0	12	3788	4059	4125	4296	4297	4463	4464	4616	4617	4766
		4570 0	35.14	3767	4038	4103	4268	4269	4429	4430	4578	4579	4723
		7930 0	21	3674	3945	4010	4177	4178	4341	4342	4491	4492	4639
		7930 0	36	3663	3933	3998	4162	4163	4323	4324	4471	4472	4615
	-10	4570 0	12	3775	4046	4112	4282	4283	4449	4450	4602	4603	4753

**Aircraft Characteristics for Airport
Planning**

Premise Condition				Ground Clearances at Spoiler Raise Status (mm)									
Mode I	Temp eratu re (°)	Weig ht (k g)	Cent er of Gravi ty (%)	SPOI LER1 IN	SPOI LER1 OUT	SPOI LER2 IN	SPOI LER2 OUT	SPOI LER3 IN	SPOI LER3 OUT	SPOI LER4 IN	SPOI LER4 OUT	SPOI LER5 IN	SPOI LER5 OUT
				UP									
		4570 0	35.14	3755	4025	4090	4255	4256	4417	4418	4565	4566	4711
		7930 0	21	3663	3933	3998	4166	4167	4330	4331	4480	4481	4627
		7930 0	36	3651	3922	3987	4151	4152	4312	4313	4459	4460	4604
	-20	4570 0	12	3762	4032	4098	4269	4270	4436	4437	4589	4590	4739
		4570 0	35.14	3742	4013	4077	4243	4244	4404	4405	4553	4554	4698
		7930 0	21	3651	3922	3987	4154	4155	4318	4319	4468	4469	4615
		7930 0	36	3640	3911	3975	4139	4140	4300	4301	4448	4448	4592
	-30	4570 0	12	3749	4019	4085	4256	4257	4422	4423	4575	4576	4725
		4570 0	35.14	3729	4000	4065	4230	4231	4392	4393	4540	4541	4686
		7930 0	21	3640	3910	3975	4143	4144	4306	4307	4456	4457	4603
		7930 0	36	3629	3899	3964	4128	4129	4288	4289	4436	4437	4580
	-40	4570 0	12	3736	4006	4072	4243	4244	4409	4410	4561	4562	4711
		4570 0	35.14	3717	3988	4052	4218	4219	4380	4381	4528	4529	4674
		7930 0	21	3628	3899	3964	4131	4132	4295	4296	4445	4445	4592
		7930 0	36	3617	3888	3953	4117	4117	4277	4278	4424	4425	4569



Interior Arrangements

Aircraft Characteristics for Airport Planning

Applicable to : ALL

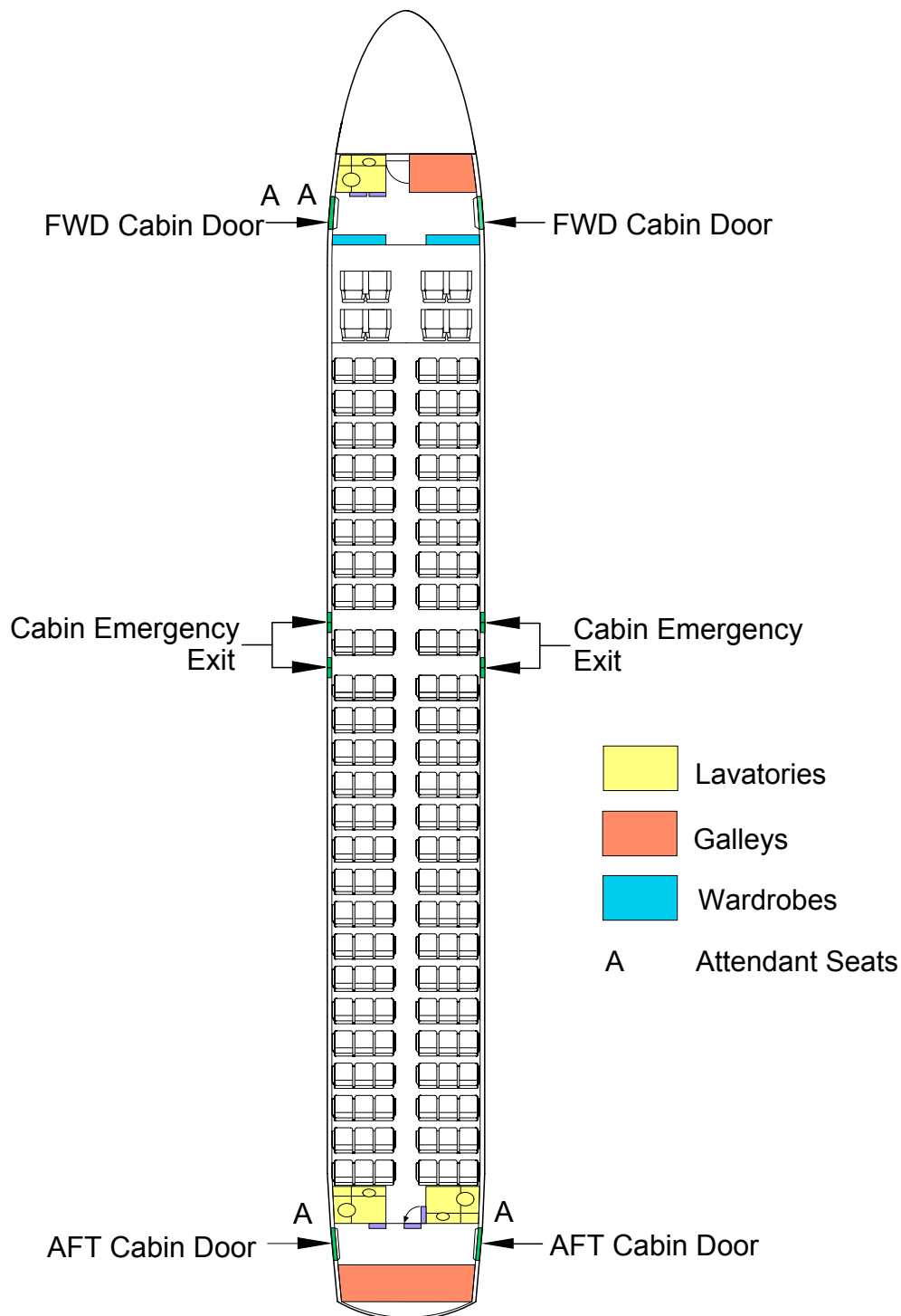

ICN-C919-A-192002-A-SVV19-10710-A-002-01

Figure 1 Combined Class with 158 Seats (Sheet 1 of 1)

Applicable to : ALL

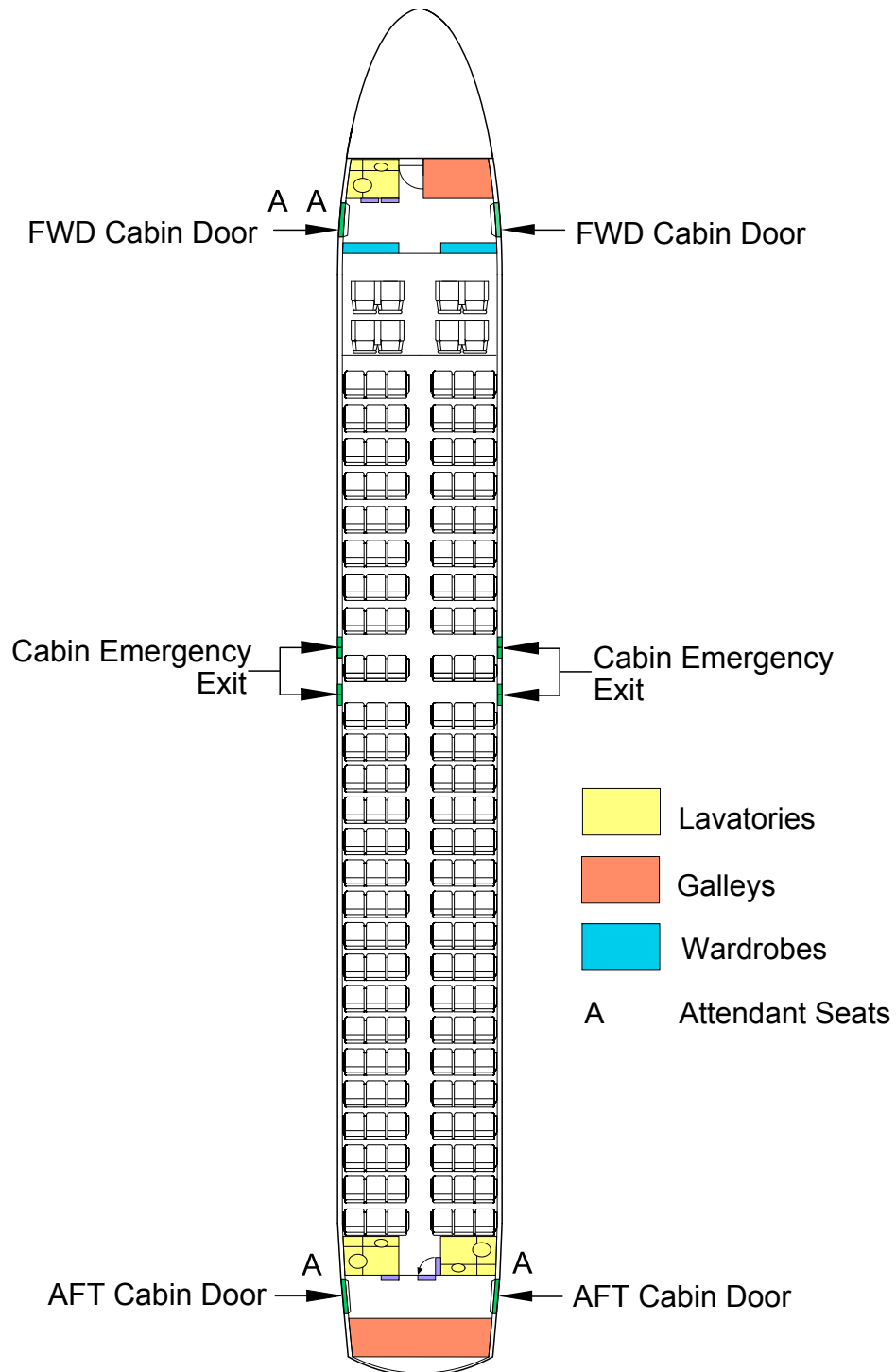

ICN-C919-A-192002-A-SVV19-78735-A-001-01

Figure 2 Combined Class with 164 Seats (Sheet 1 of 1)

Applicable to : ALL

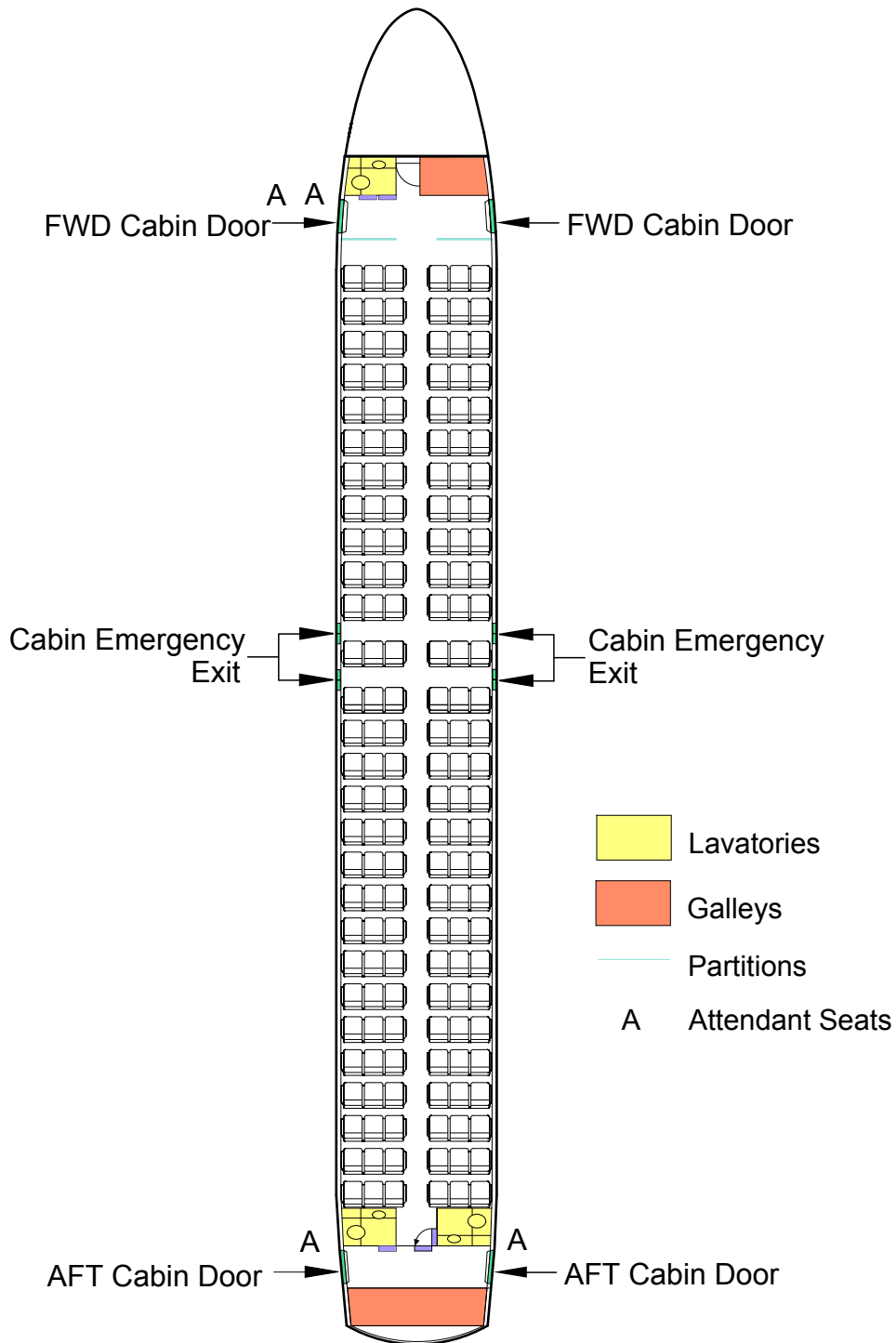

ICN-C919-A-192002-A-SVV19-10711-A-002-01

Figure 3 Economy Class with 168 Seats (Sheet 1 of 1)

Applicable to : ALL

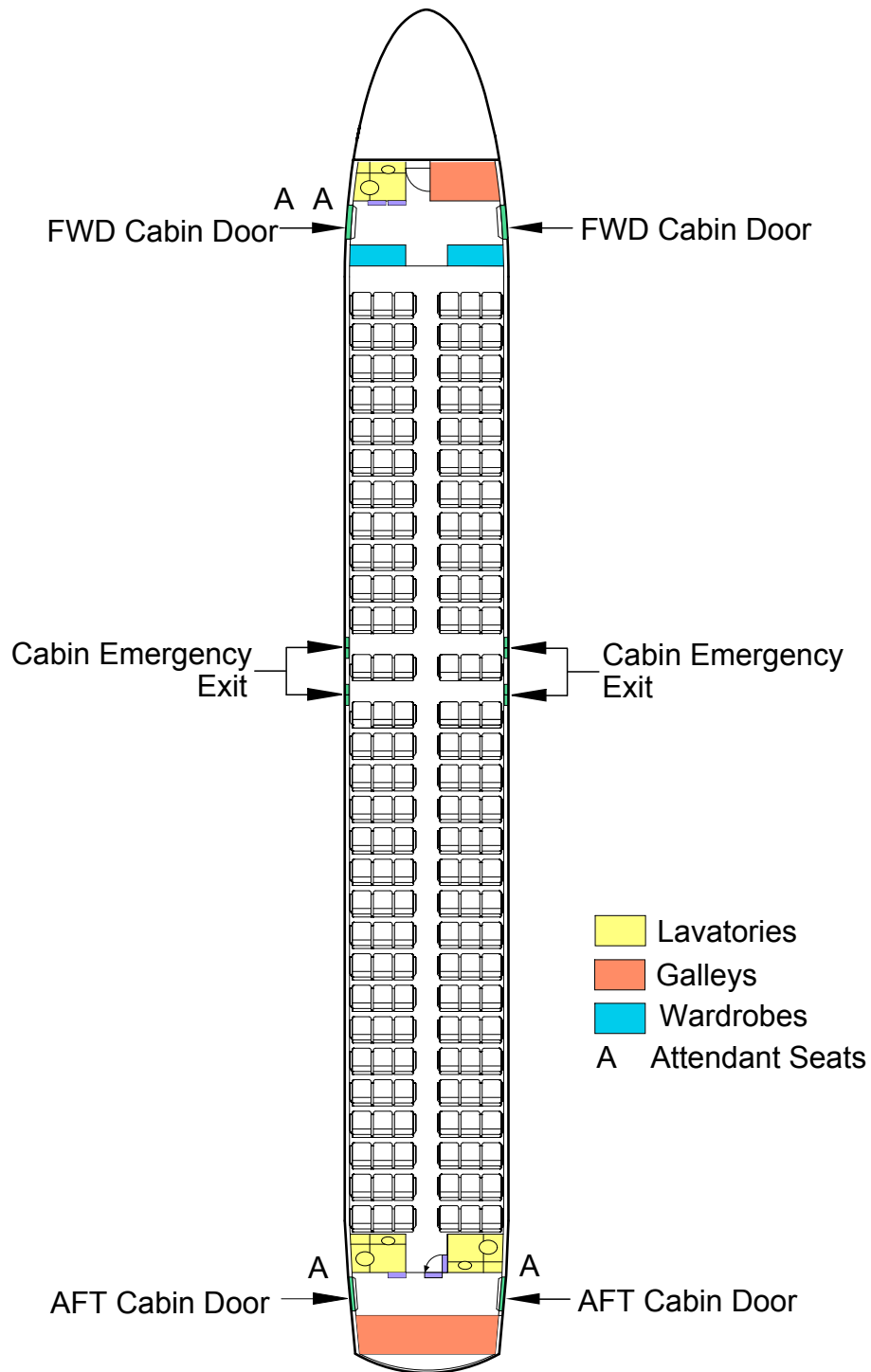

ICN-C919-A-192002-A-SVV19-10712-A-002-01

Figure 4 High Intensity Class with 174 Seats (Sheet 1 of 1)

Passenger Compartment Cross-Section

Applicable to : ALL

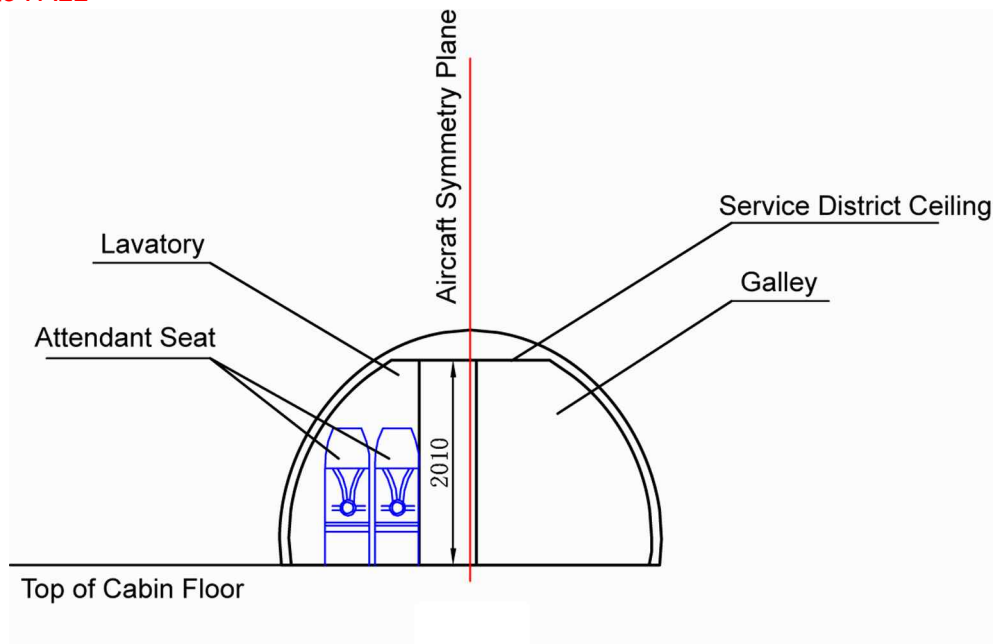

ICN-C919-A-192002-A-SVV19-10809-A-004-01

Figure 1 Passenger Compartment Cross-section (Sheet 1 of 5)

Applicable to : ALL

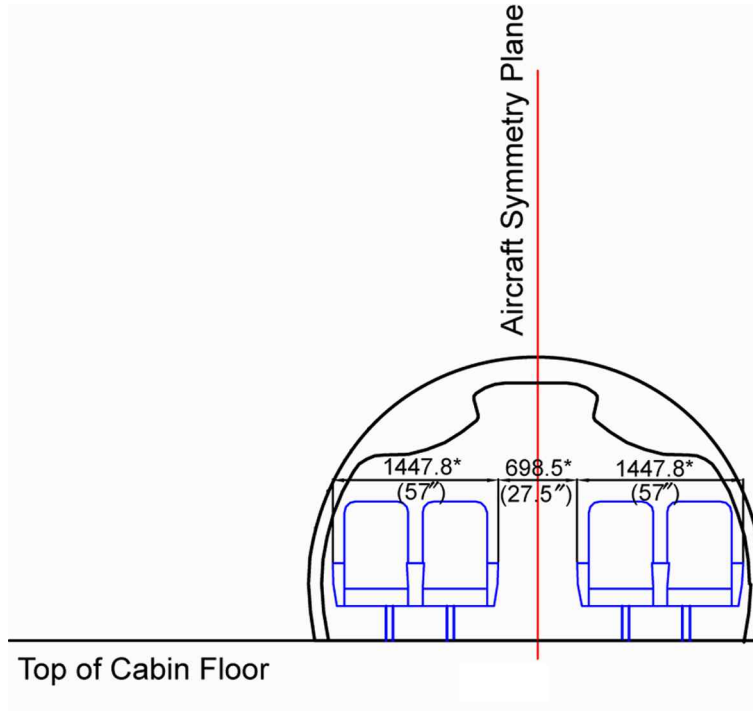

ICN-C919-A-192002-A-SVV19-39097-A-002-01

Figure 1 Passenger Compartment Cross-section (Sheet 2 of 5)

Applicable to : ALL

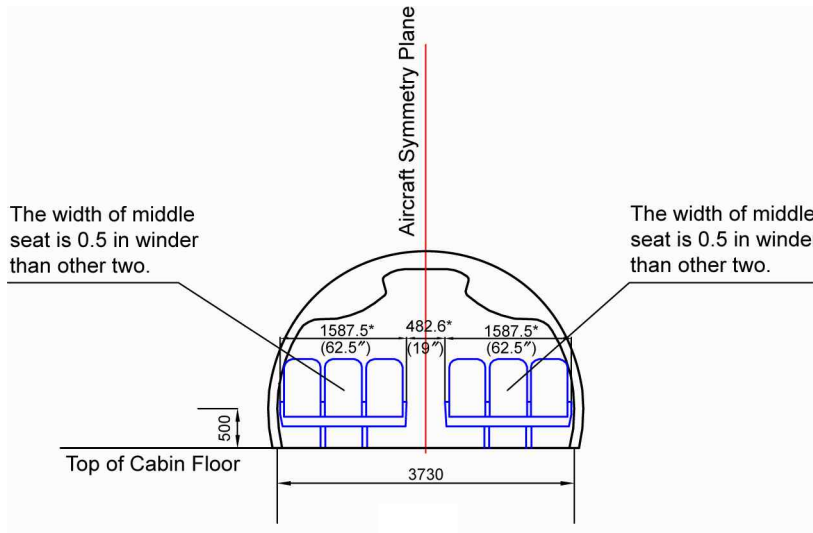

ICN-C919-A-192002-A-SVV19-39098-A-002-01

Figure 1 Passenger Compartment Cross-section (Sheet 3 of 5)

Applicable to : ALL

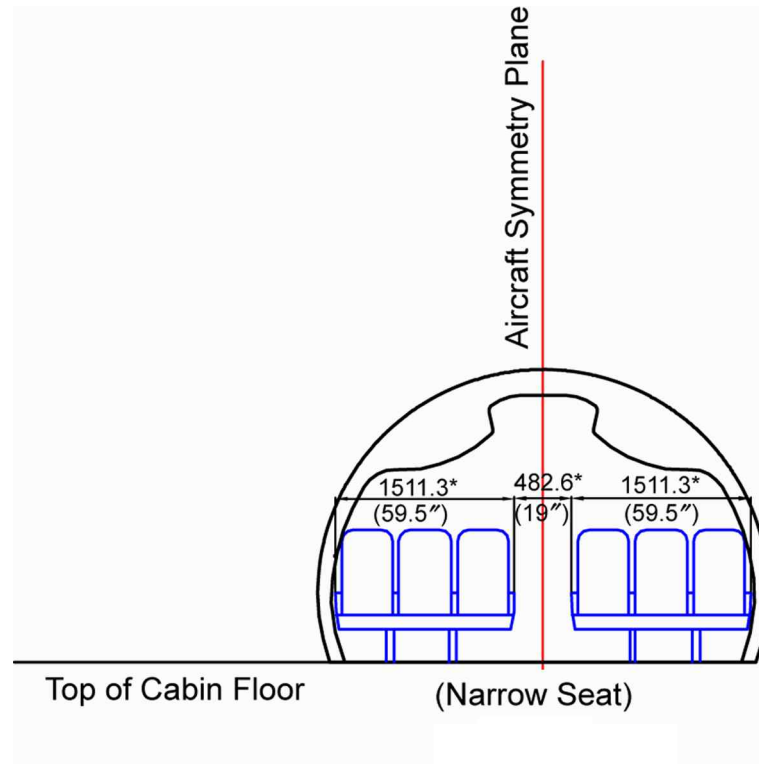

ICN-C919-A-192002-A-SVV19-39099-A-002-01

Figure 1 Passenger Compartment Cross-section (Sheet 4 of 5)

Applicable to : ALL

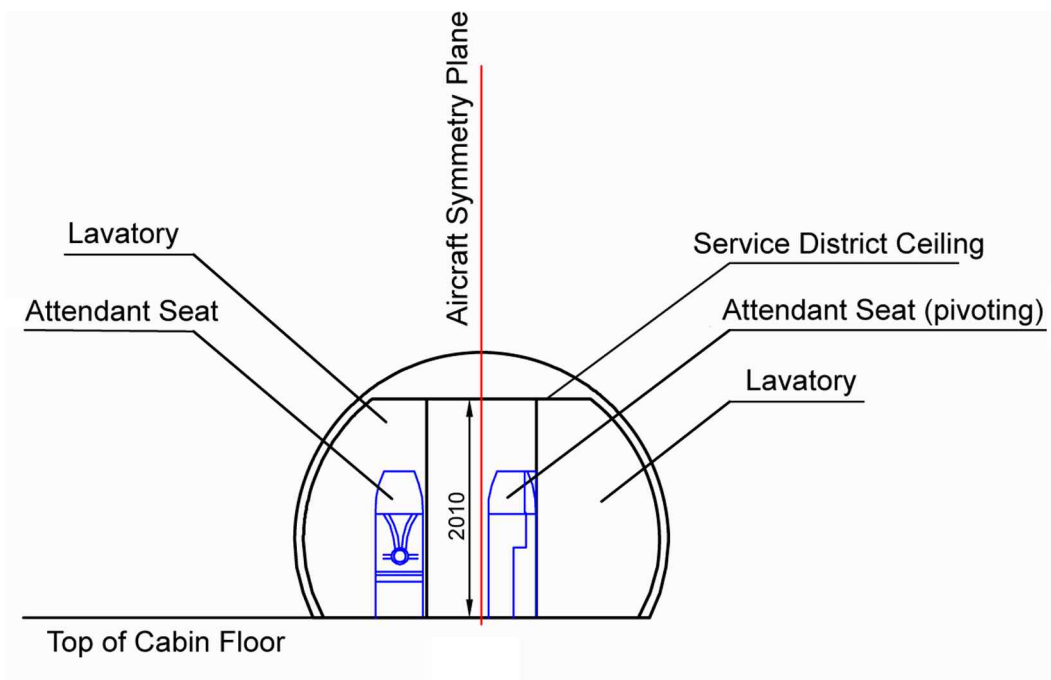

ICN-C919-A-192002-A-SVV19-39100-A-002-01

Figure 1 Passenger Compartment Cross-section (Sheet 5 of 5)

Lower Deck Compartments

Applicable to : ALL

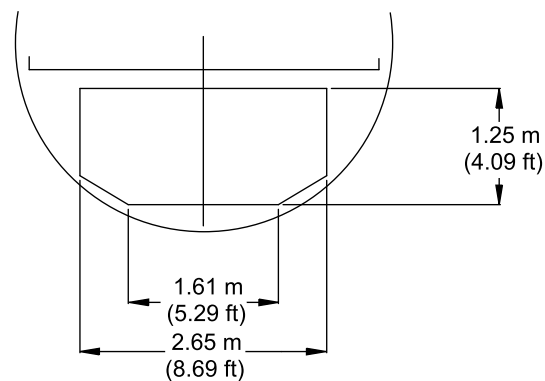
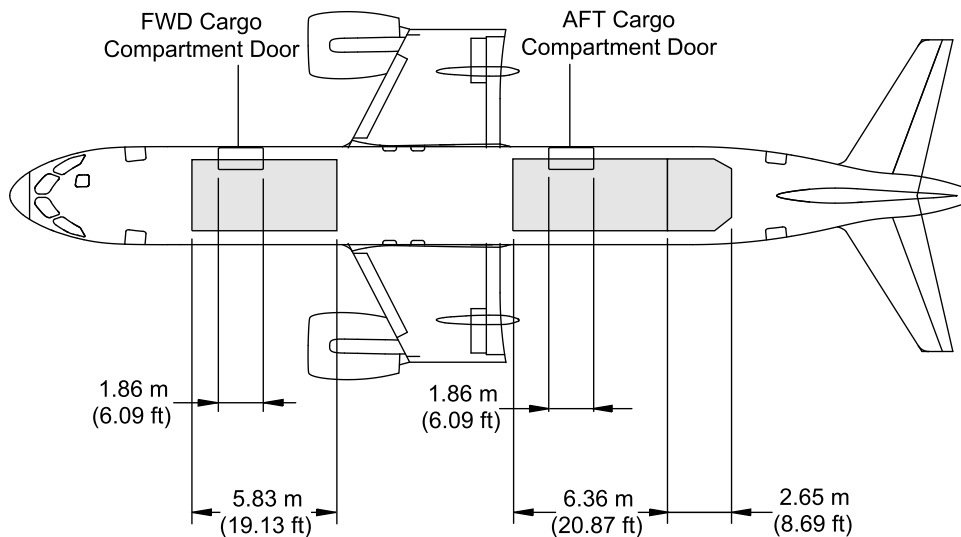
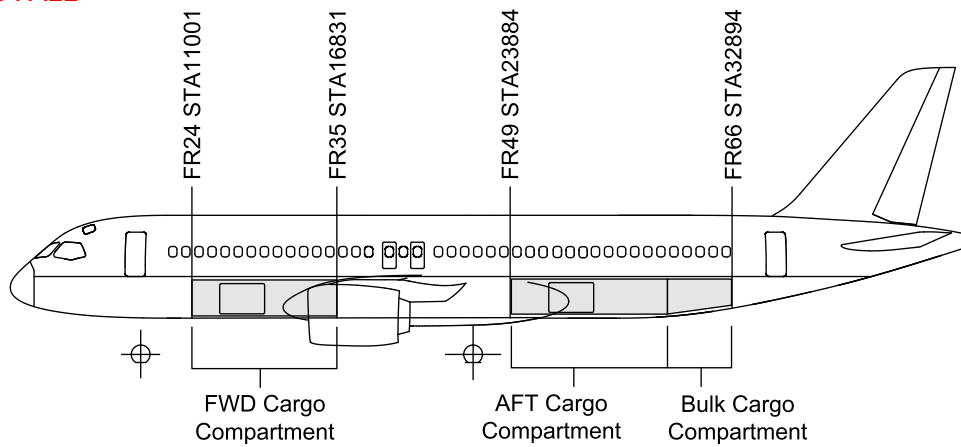

Lower Deck Cargo Compartment Dimensions

ICN-C919-A-192002-A-SVV19-10810-A-003-01

Figure 1 Lower Cargo Compartments (Sheet 1 of 1)

**Aircraft Characteristics for Airport
Planning**
Table 1 Lower Cargo Compartment - Capacities

Unit	FWD Cargo Compartment	AFT Cargo Compartment (Bulk Cargo Included)
M ³	18.1	27.1
FT ³	639.2	957.0

Table 2 Lower Cargo Compartment - Available Capacities

Unit	FWD Cargo Compartment	AFT Cargo Compartment (Bulk Cargo Included)
M ³	15.367	21.731
FT ³	542.68	767.42



Door Clearances

Aircraft Characteristics for Airport Planning

Applicable to : ALL

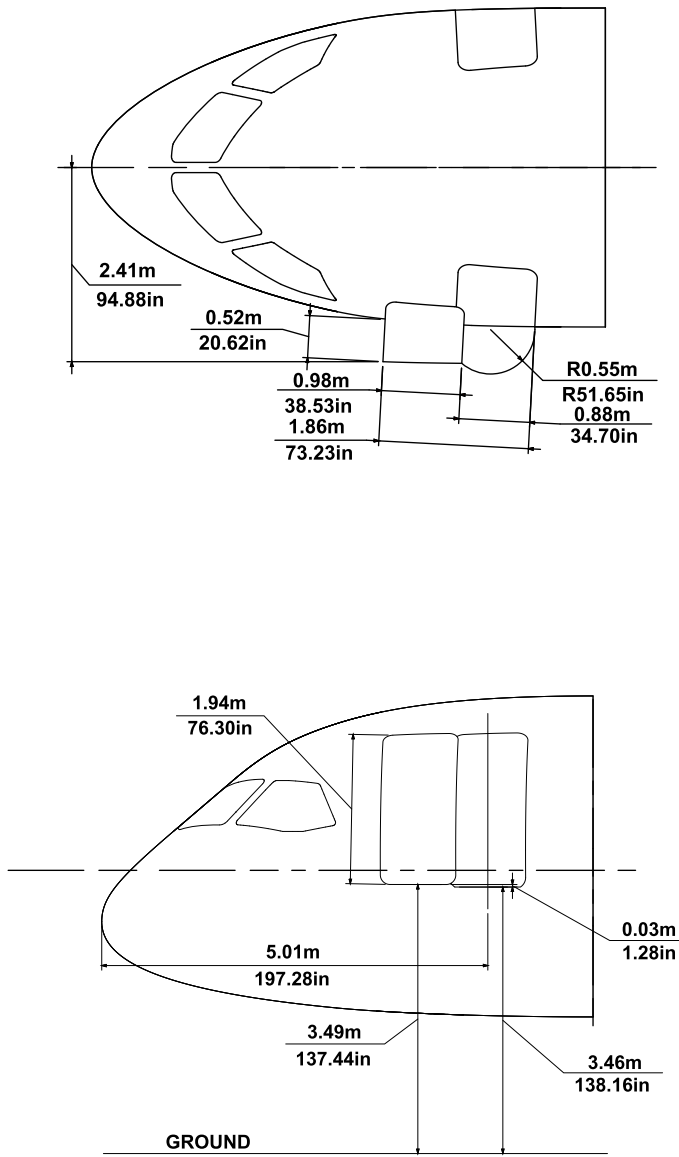

ICN-C919-A-192002-A-SVV19-10822-A-003-01

Figure 1 Forward Passenger entry Door Clearances (Sheet 1 of 1)

Applicable to : ALL

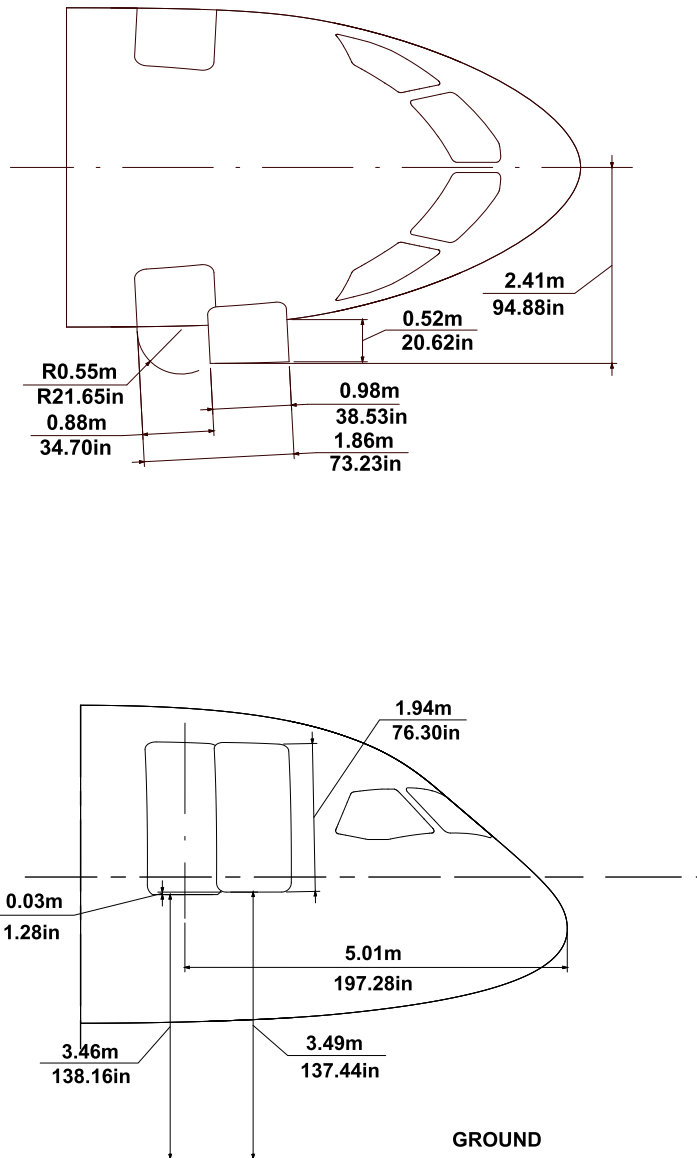

ICN-C919-A-192002-A-SVV19-10823-A-003-01

Figure 2 Forward Service Door Clearances (Sheet 1 of 1)

Applicable to : ALL

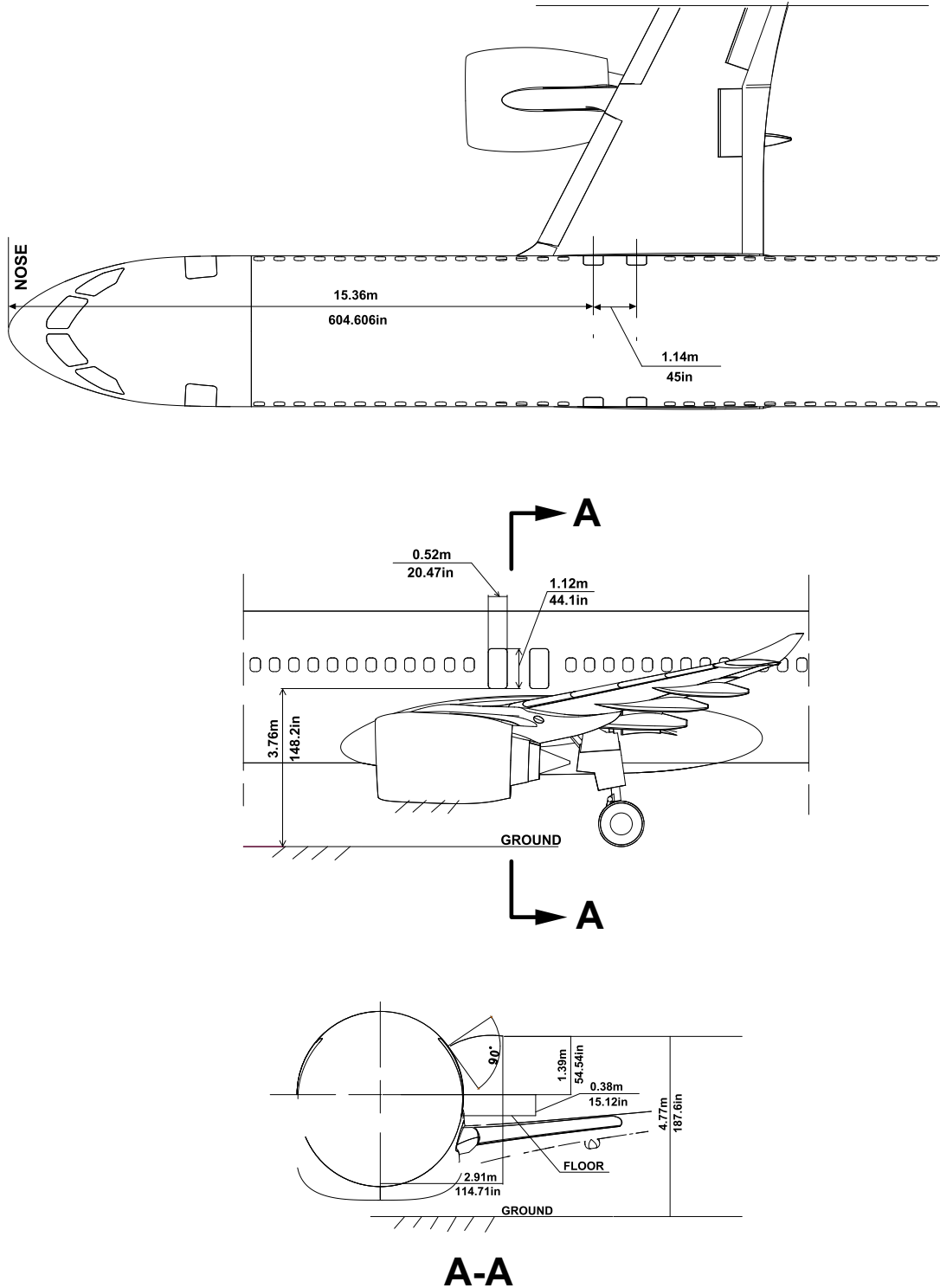

ICN-C919-A-192002-A-SVV19-10824-A-003-01

Figure 3 Emergency Exit Door Clearances (Sheet 1 of 1)

Applicable to : ALL

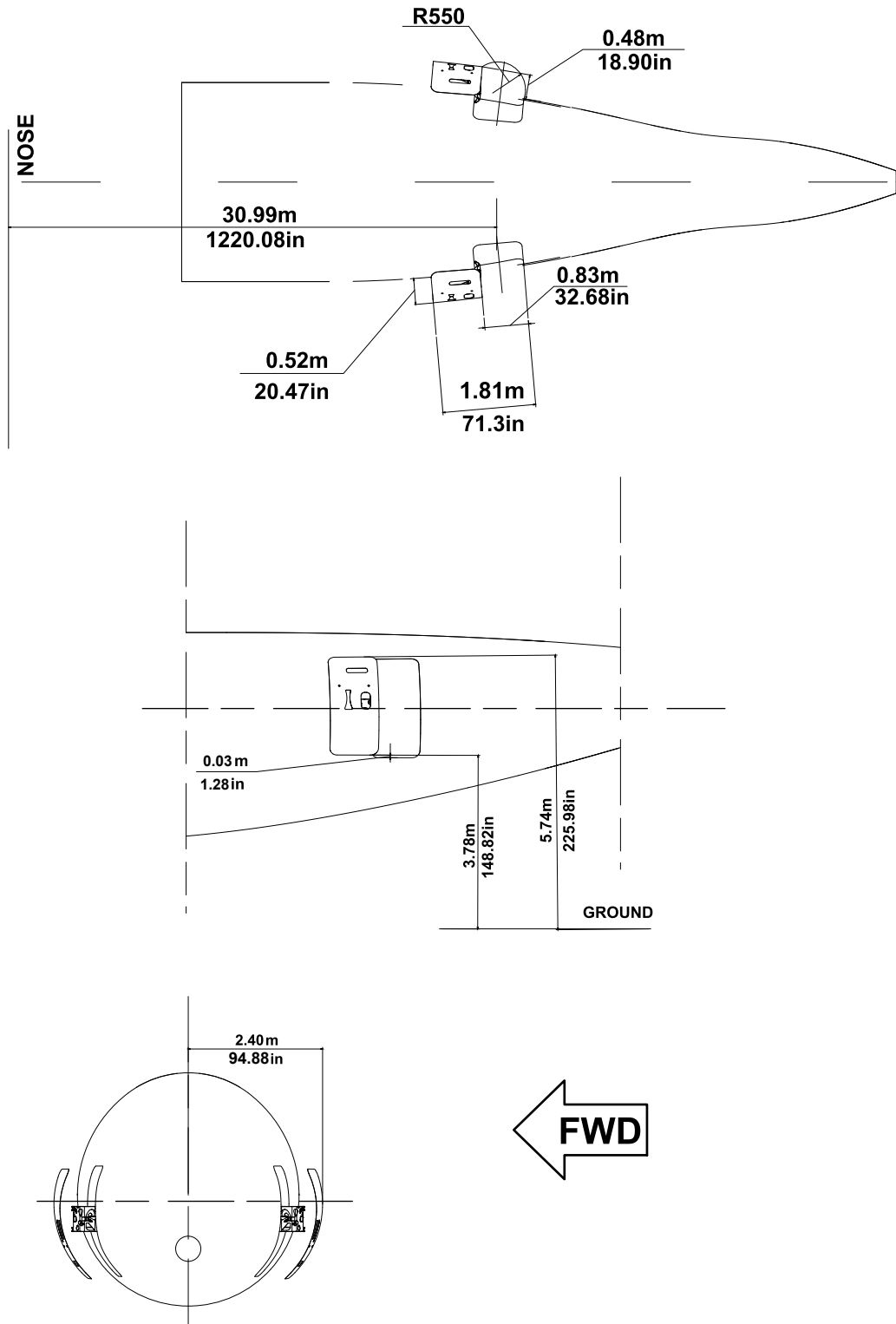

ICN-C919-A-192002-A-SVV19-10825-A-005-01

Figure 4 After Passenger Entry Door Clearances (Sheet 1 of 1)

Aircraft Characteristics for Airport Planning

Applicable to : ALL

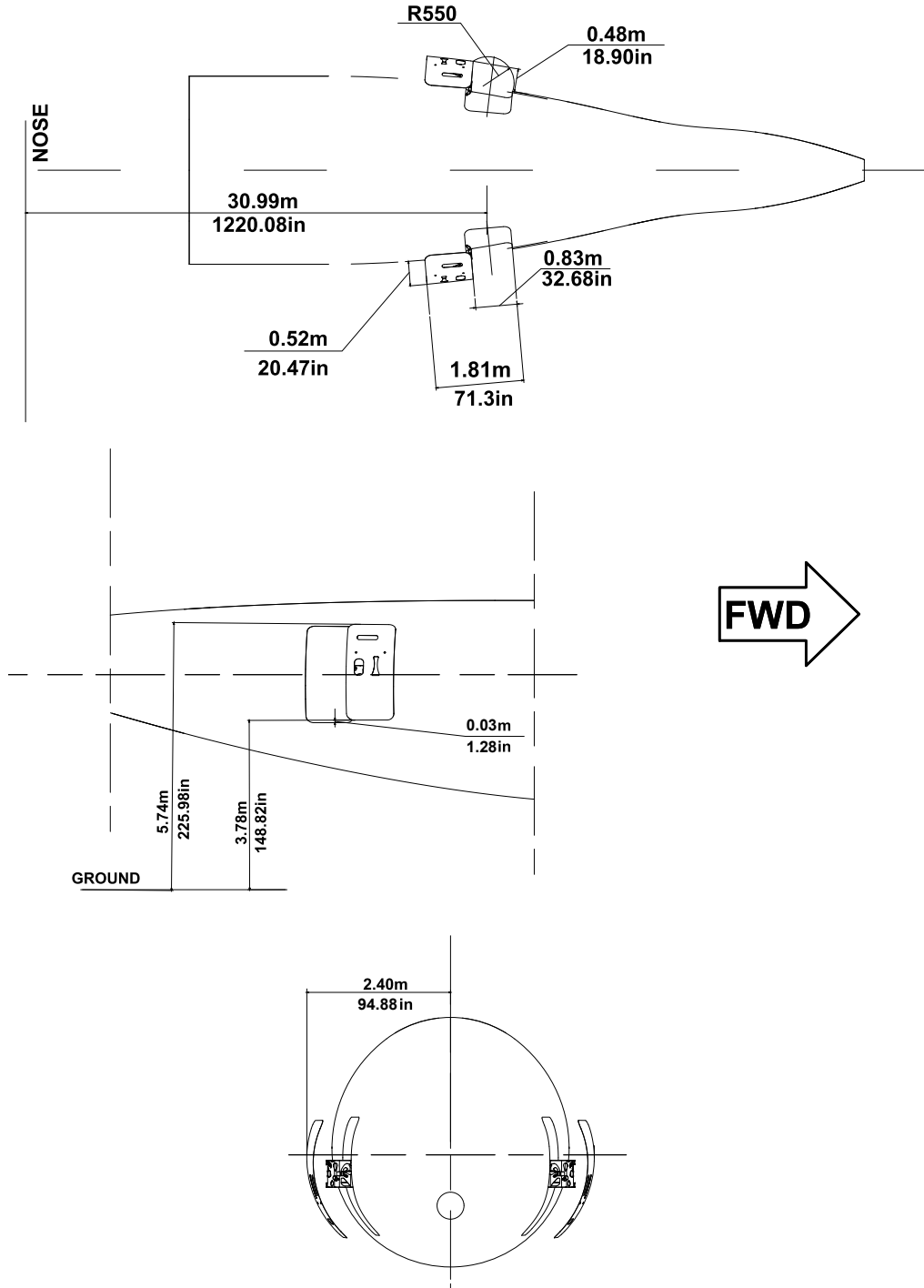

ICN-C919-A-192002-A-SVV19-10826-A-005-01

Figure 5 After Service Door Clearances (Sheet 1 of 1)

Applicable to : ALL

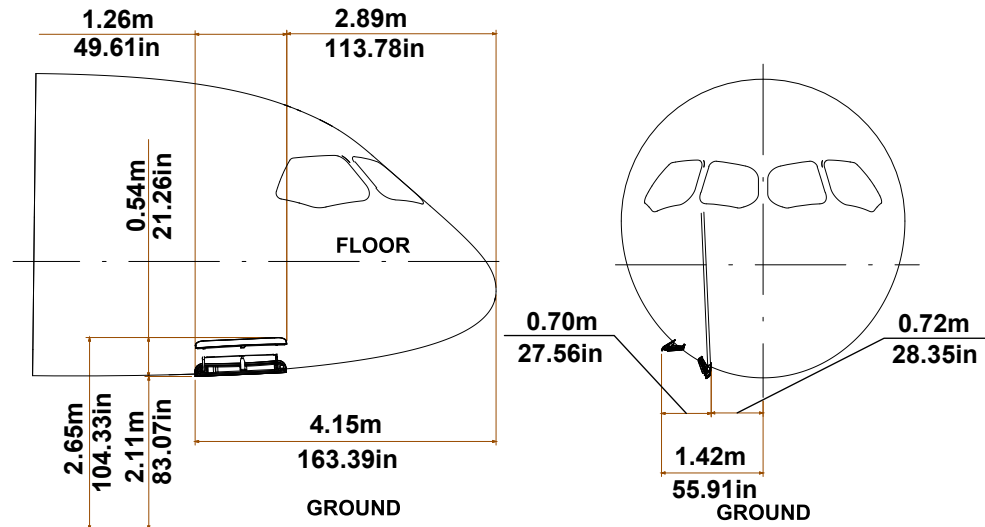
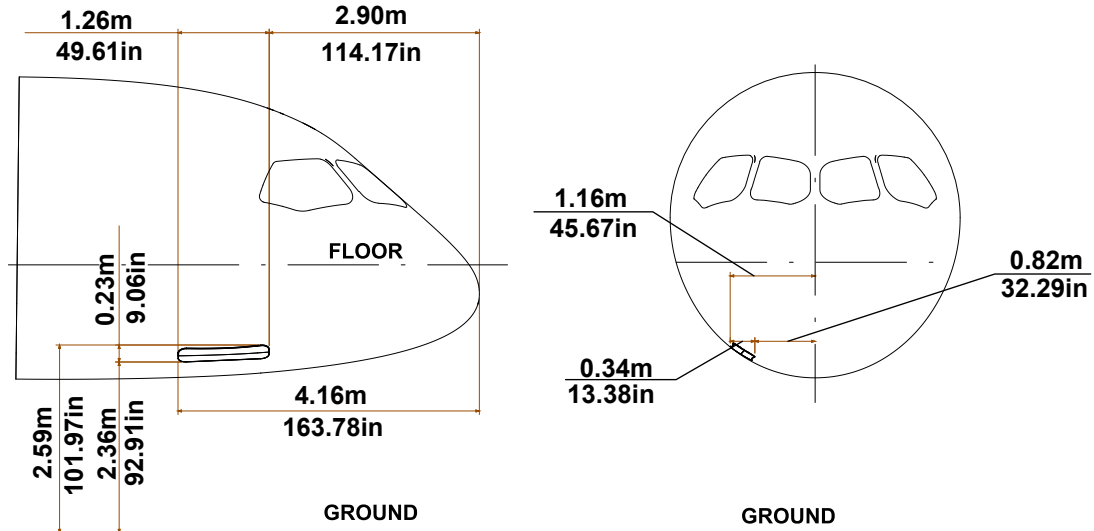

ICN-C919-A-192002-A-SVV19-10827-A-003-01

Figure 6 Rat Compartment Door Clearances (Sheet 1 of 1)



Applicable to : ALL

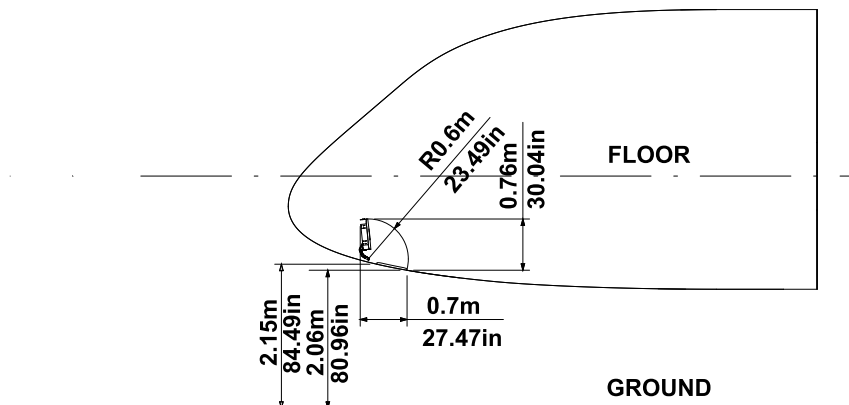
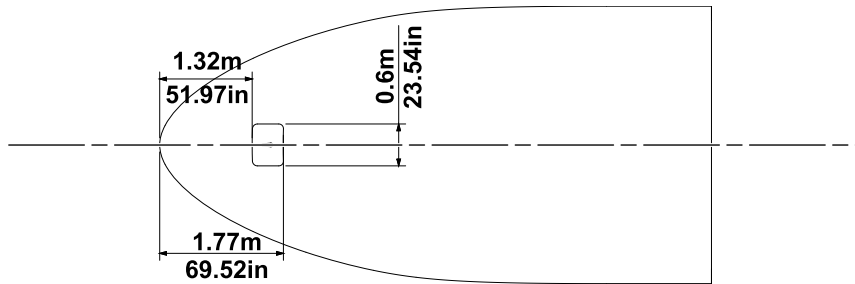

ICN-C919-A-192002-A-SVV19-10828-A-004-01

Figure 7 Forward E/E equipment compartment Door Clearances (Sheet 1 of 3)

Applicable to : ALL

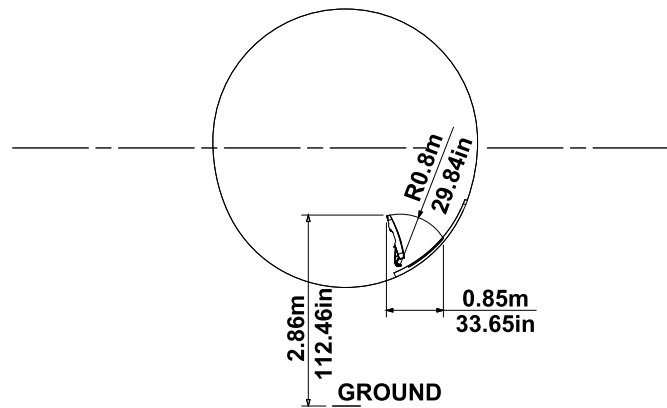
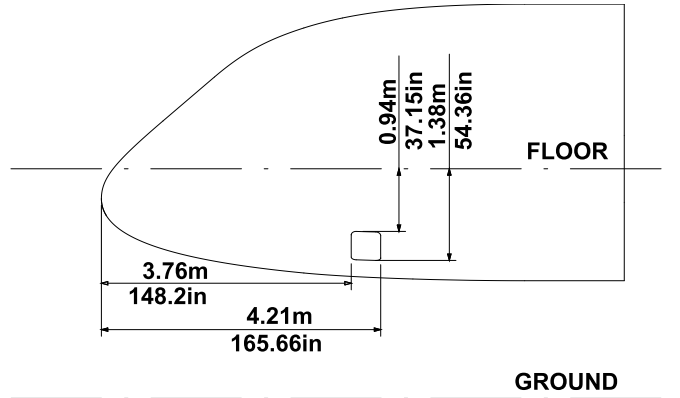

ICN-C919-A-192002-A-SVV19-37814-A-002-01

Figure 7 Forward E/E equipment compartment Door Clearances (Sheet 2 of 3)

Applicable to : ALL

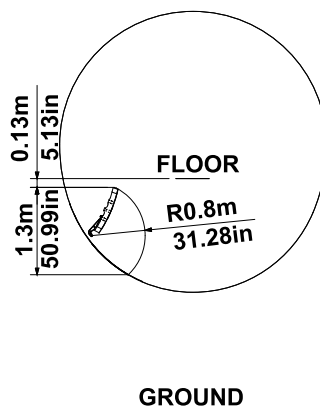
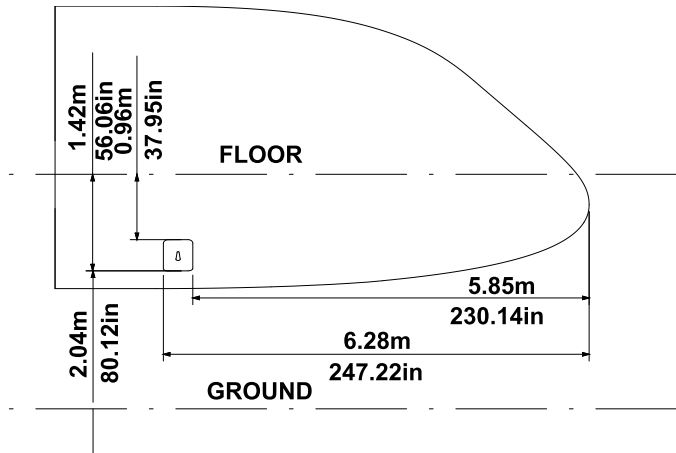

ICN-C919-A-192002-A-SVV19-64479-A-002-01

Figure 7 Forward E/E equipment compartment Door Clearances (Sheet 3 of 3)

Applicable to : ALL

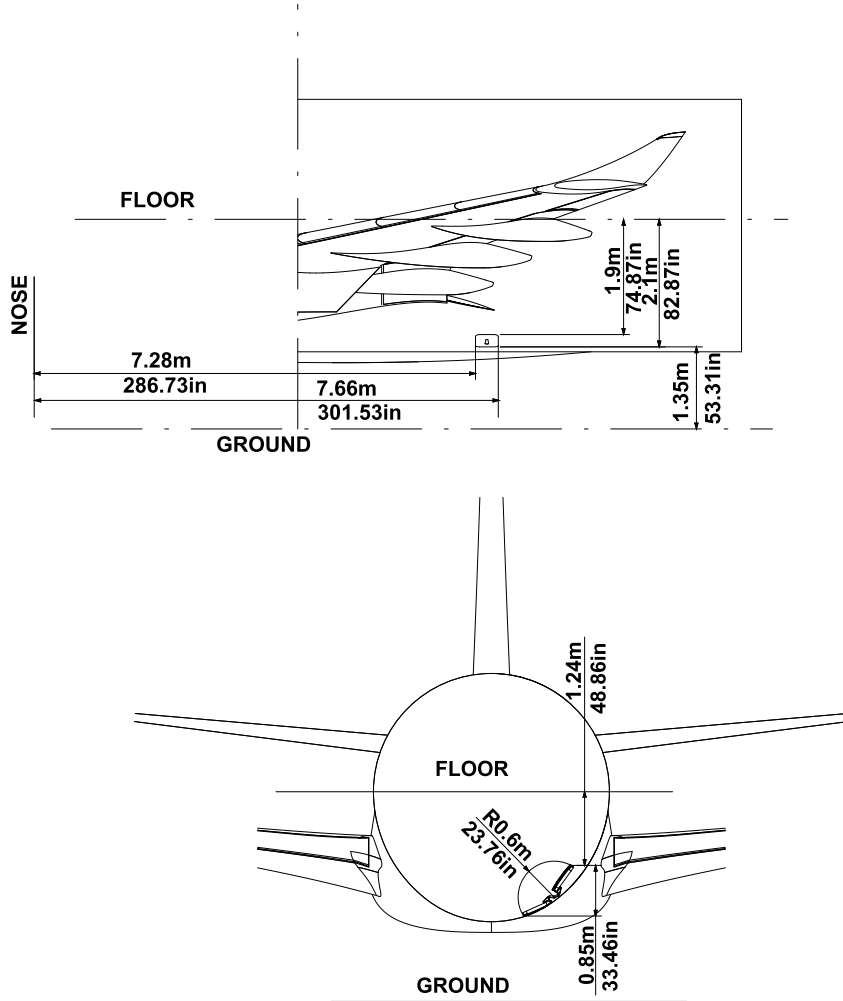

ICN-C919-A-192002-A-SVV19-70414-A-001-01

Figure 8 Medium E/E equipment compartment Door Clearances (Sheet 1 of 1)

Applicable to : ALL

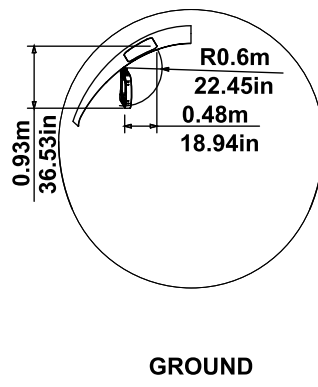
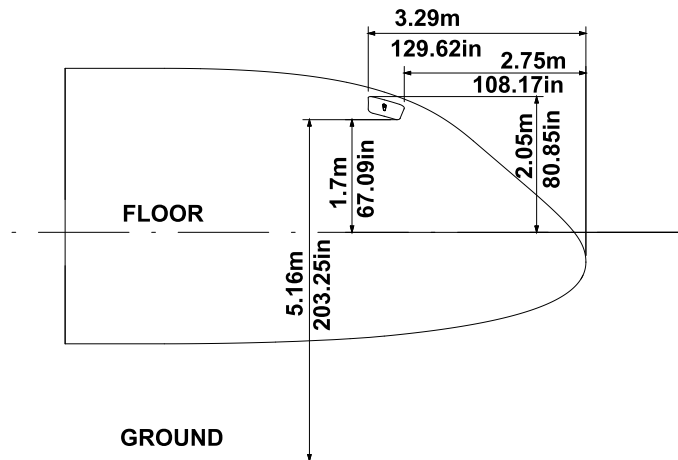

ICN-C919-A-192002-A-SVV19-64478-A-002-01

Figure 9 Cockpit Emergency Exit (Sheet 1 of 1)

Aircraft Characteristics for Airport Planning

Applicable to : ALL

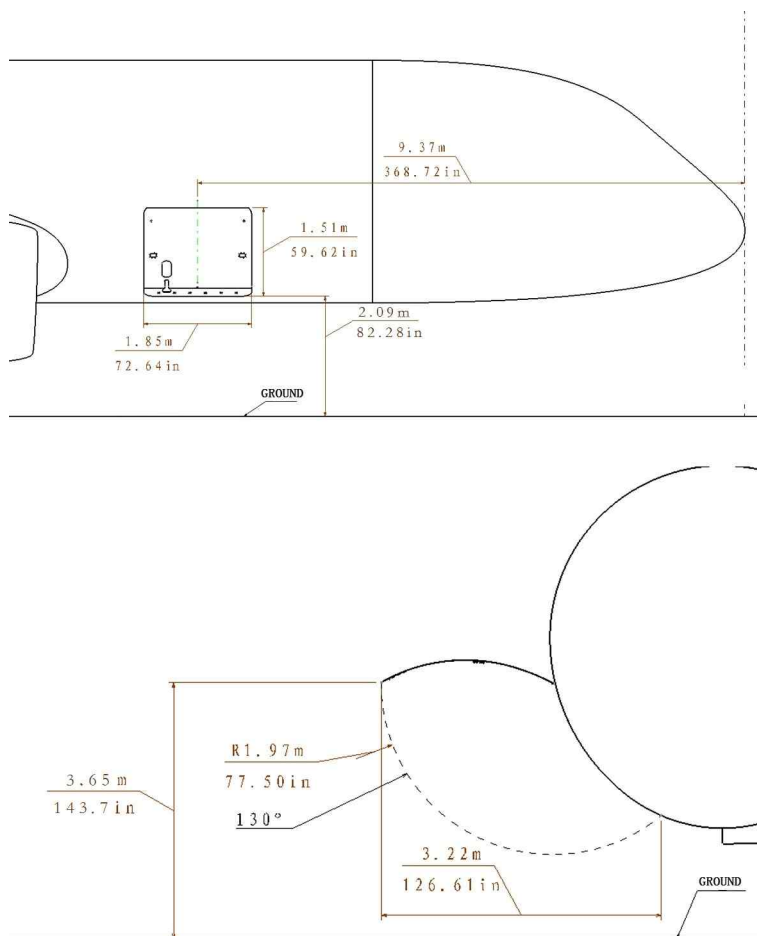

ICN-C919-A-192002-A-SVV19-70417-A-002-01

Figure 10 Fwd Cargo Door Clearances (Sheet 1 of 1)

Applicable to : ALL

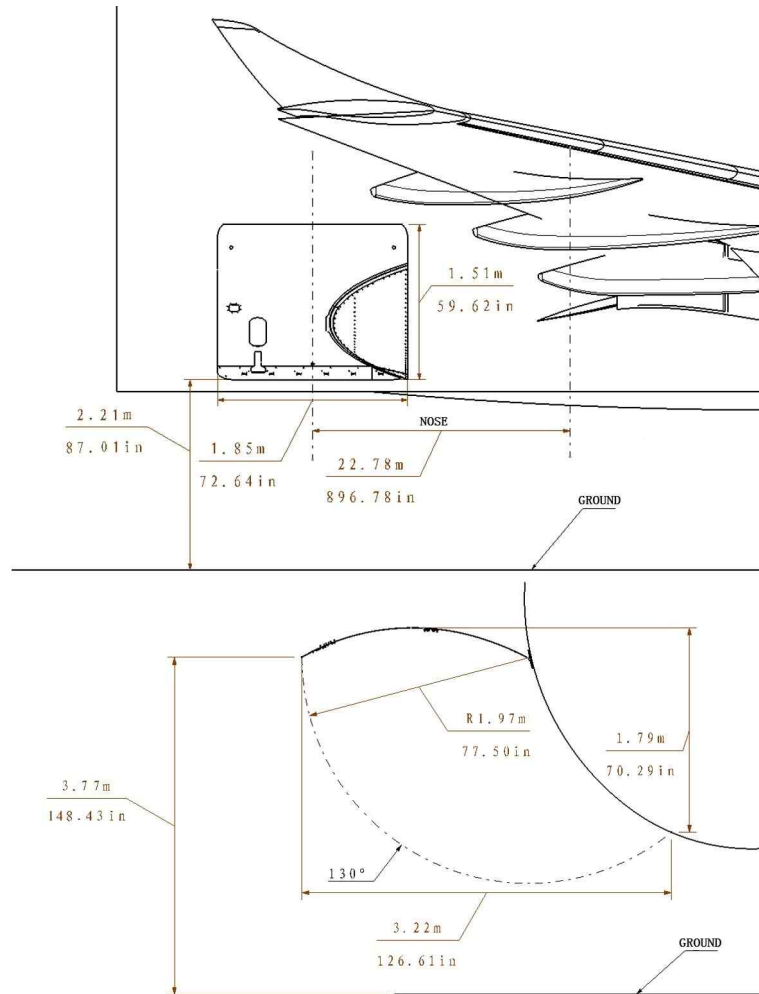

ICN-C919-A-192002-A-SVV19-70418-A-002-01

Figure 11 AFT Cargo Door Clearances (Sheet 1 of 1)

Intentionally left blank

Evacuation Slide

One single-lane evacuation slide is installed in each cabin door, and one dual-lane evacuation slide is installed in each wing-to-body fairing on the fuselage.

Left and right over-wing slides are always armed.

Applicable to : ALL

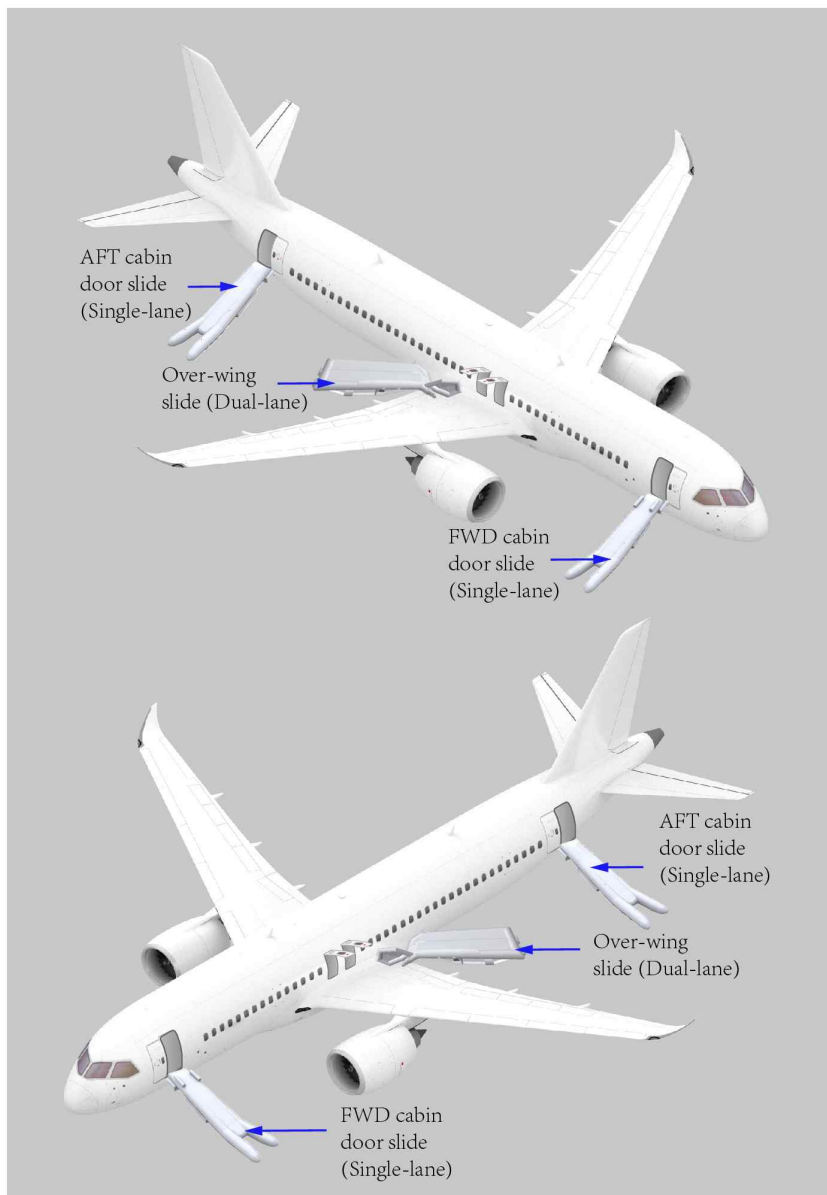

ICN-C919-A-192002-A-SVV19-78338-A-001-01

Figure 1 Evacuation Slide (Sheet 1 of 1)

Applicable to : ALL

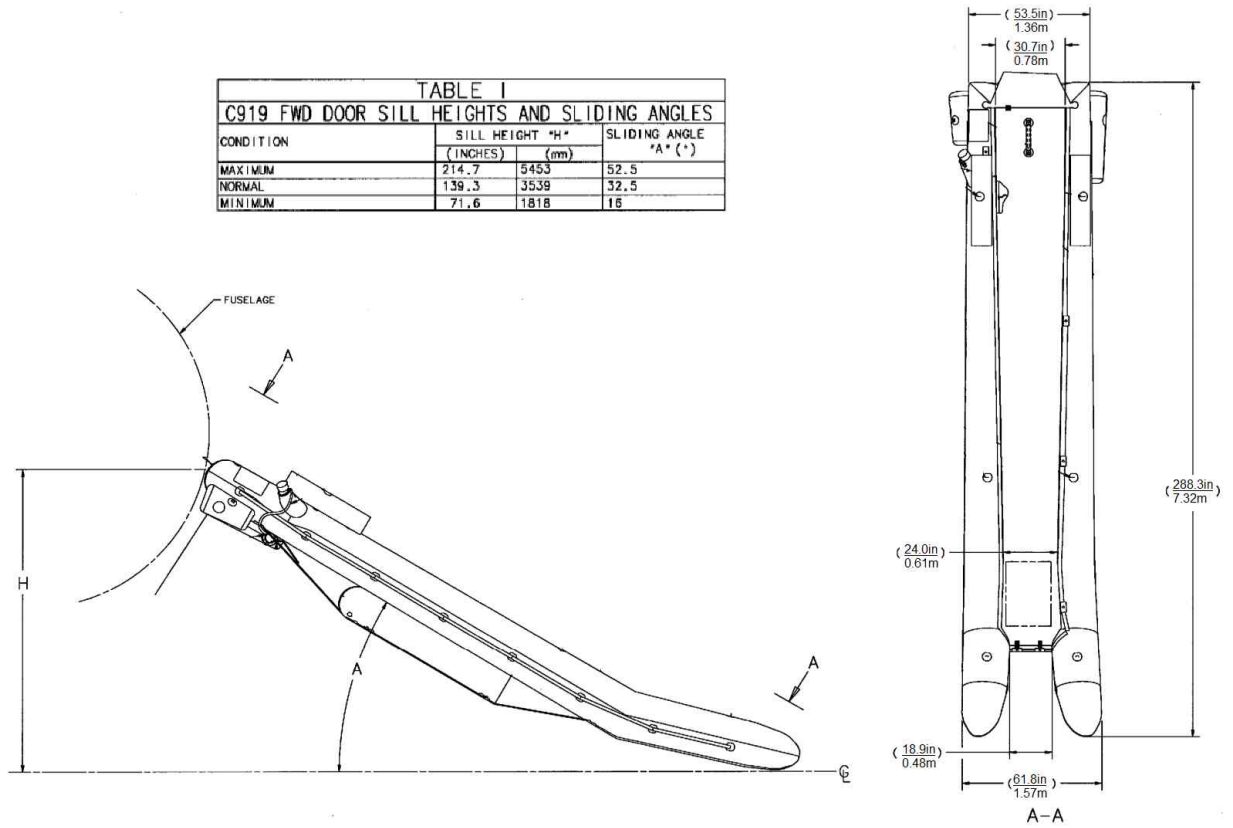

ICN-C919-A-192002-A-SVV19-89271-A-001-01

Figure 2 C919 Emergency Evacuation Slides for FWD doors (Sheet 1 of 1)

Applicable to : ALL

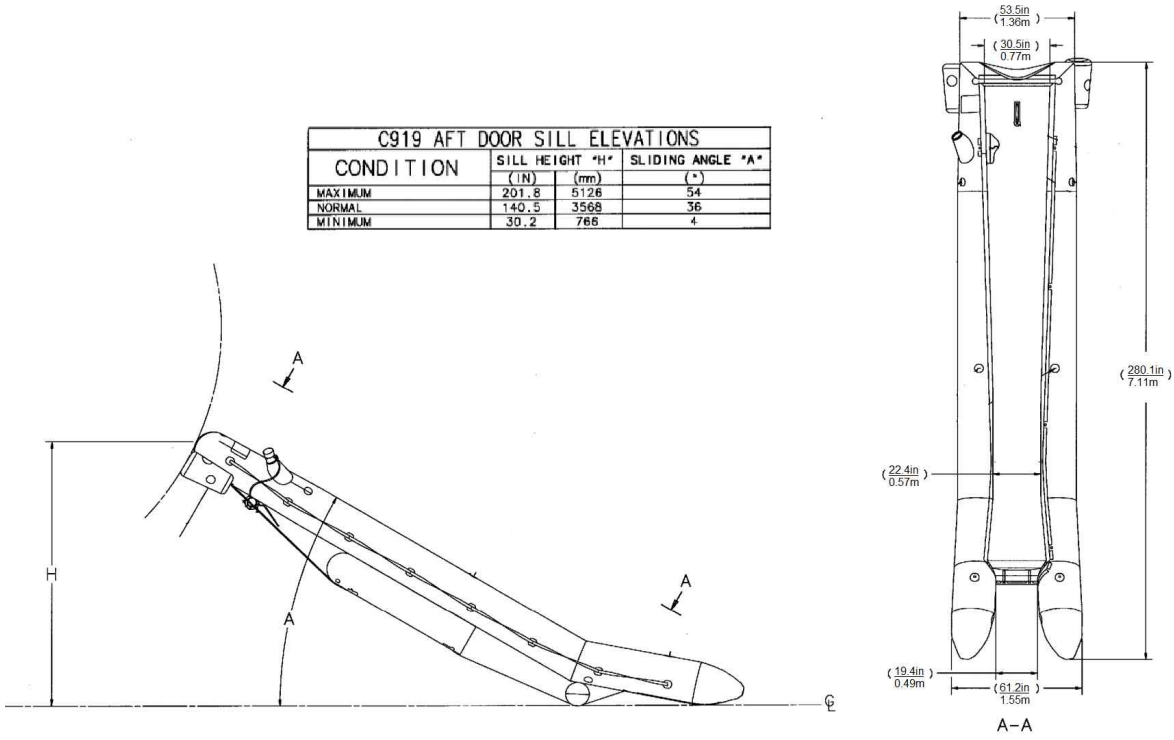

ICN-C919-A-192002-A-SVV19-89272-A-001-01

Figure 3 C919 Emergency Evacuation Slide System AFT Doors (Sheet 1 of 1)

Applicable to : ALL

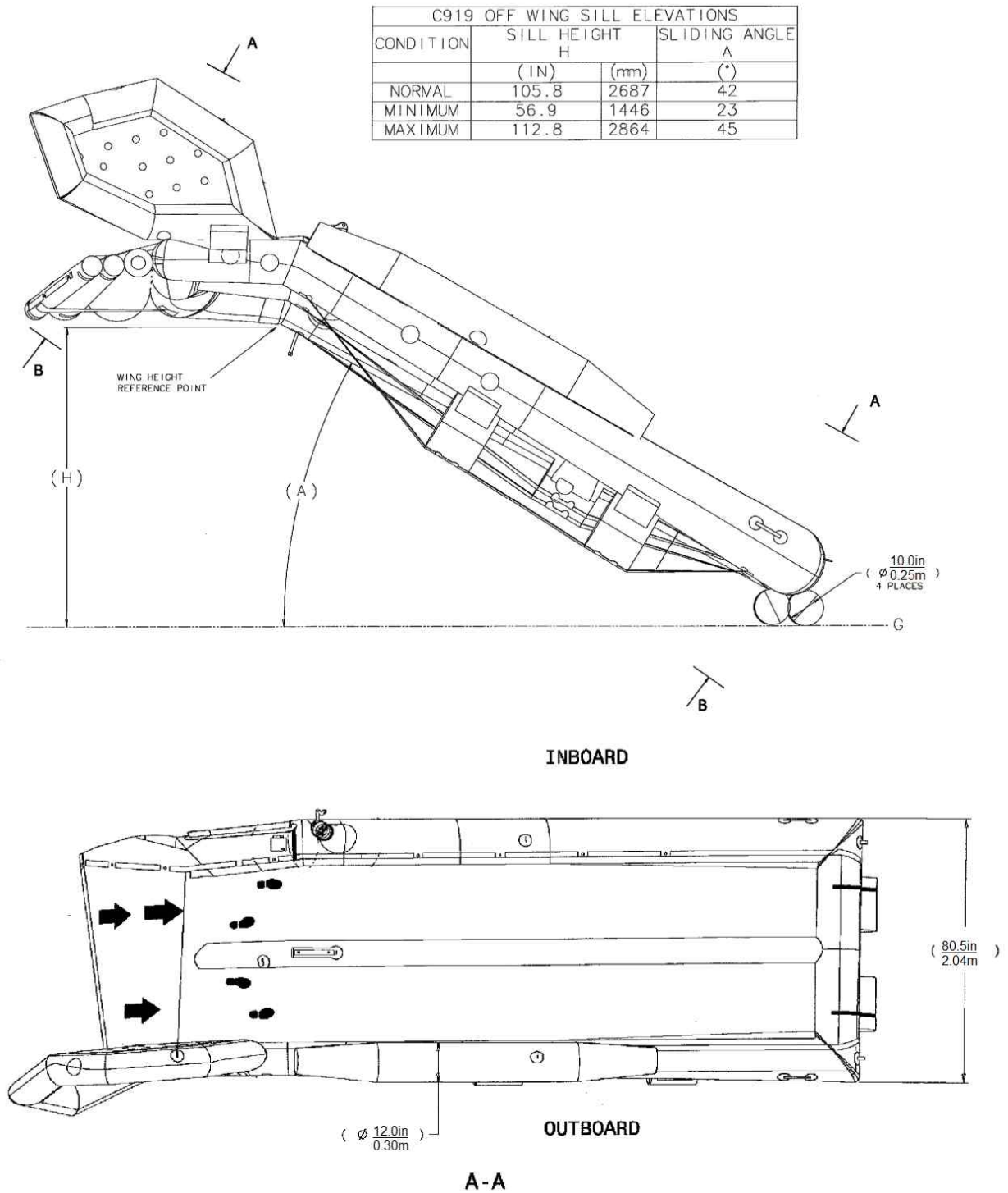

ICN-C919-A-192002-A-SVV19-89273-A-001-01

Figure 4 C919 Evacuation Offwing Slide System (Sheet 1 of 1)

Intentionally left blank

Landing Gear

1. Description

The landing gear system is a tricycle layout undercarriage, including:

- Two inboard retracting main landing gear
- One FWD retracting nose landing gear

Landing gear is electrically controlled and hydraulically powered.

Each main landing gear has three doors. The inner door is hydraulically powered. The outer and middle doors are mechanically operated by the gear.

Applicable to : ALL

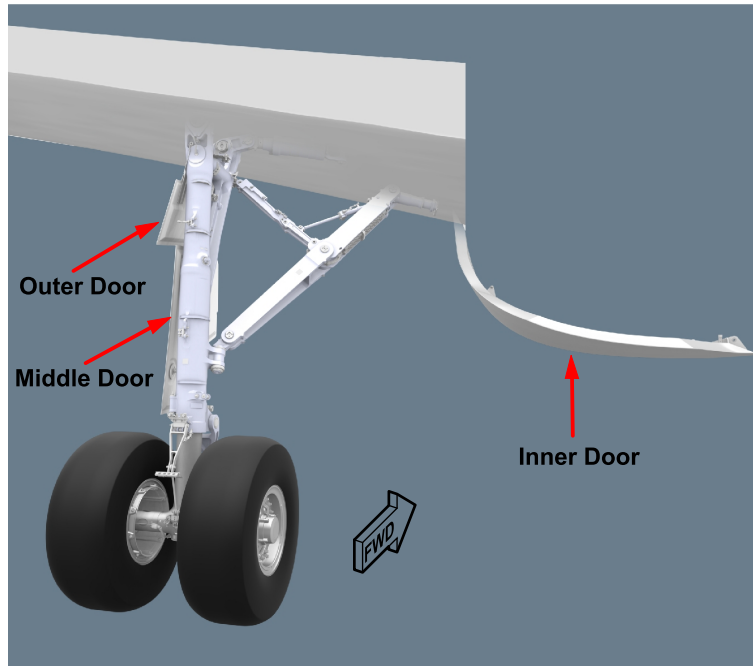

ICN-C919-A-170132-A-SVV19-28118-A-002-01

Figure 1 Main Landing Gear + Door (Sheet 1 of 1)

Nose landing gear has four doors. Two FWD doors are hydraulically powered. Two AFT doors are mechanically operated by the gear.

Applicable to : ALL

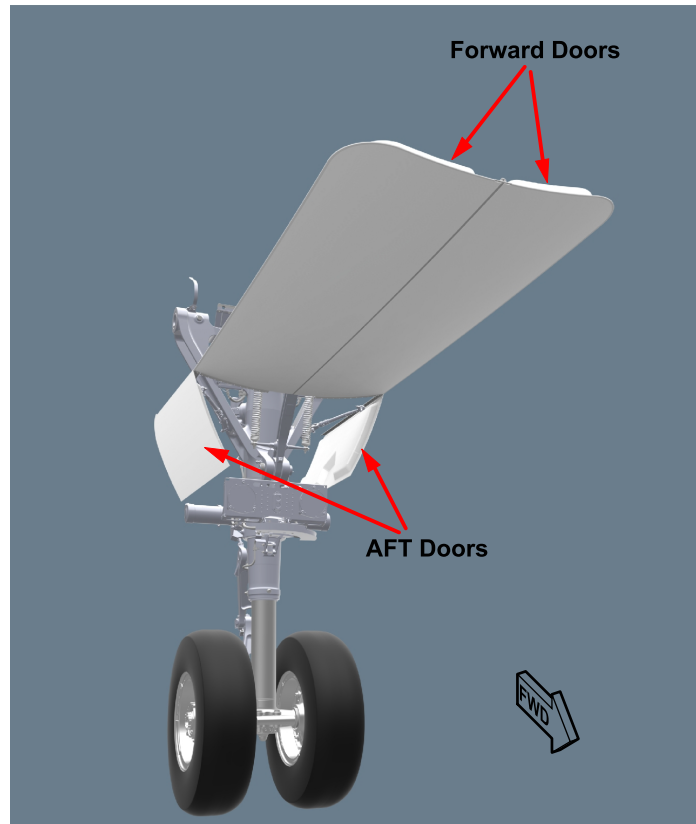

ICN-C919-A-170132-A-SVV19-28115-A-003-01

Figure 2 Nose Landing Gear + Door (Sheet 1 of 1)

During maintenance tasks, the nose landing gear forward doors and main landing gear inner doors can be open or closed by the landing gear doors open/close switch. The switch is located in the ground power panel in front of the nose gear wheel well.

2. Landing Gear Structure

Applicable to : ALL

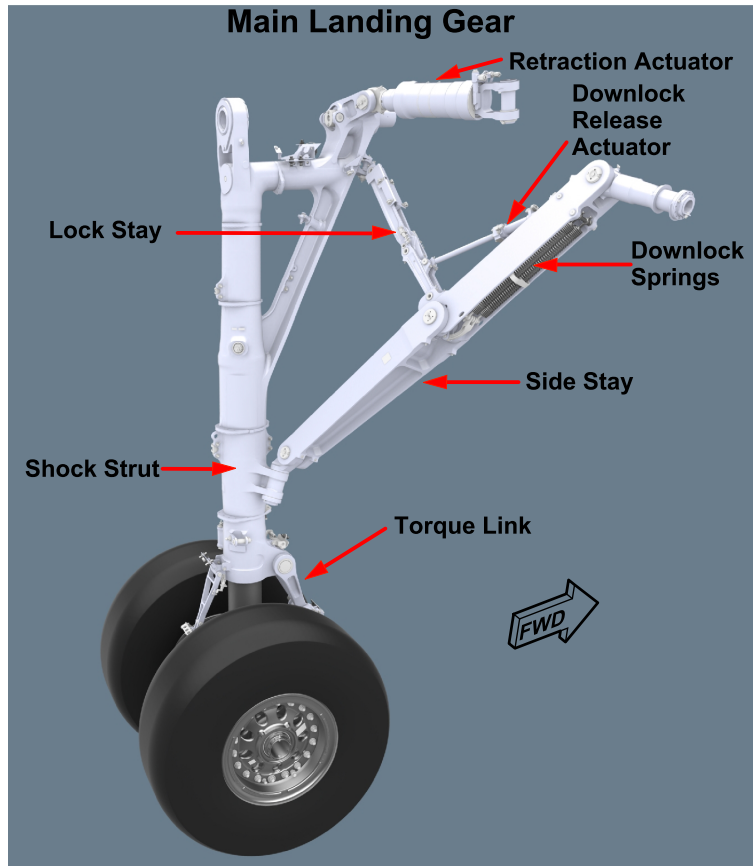

ICN-C919-A-170132-A-SVV19-10862-A-005-01

Figure 3 Main Landing Gear Structure (Sheet 1 of 2)

Applicable to : ALL

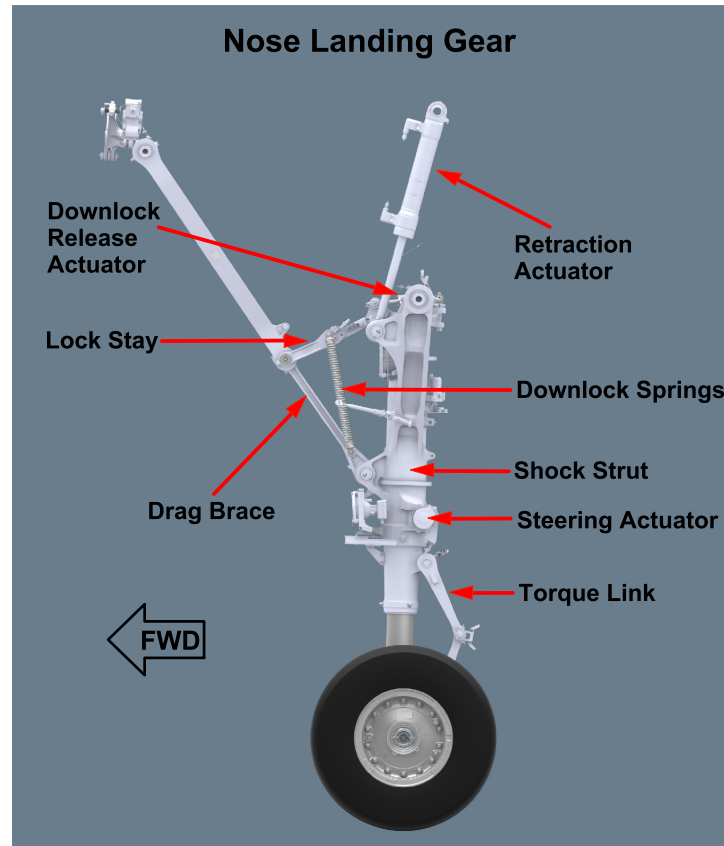

ICN-C919-A-170132-A-SVV19-10863-A-006-01

Figure 3 Main Landing Gear Structure (Sheet 2 of 2)

Each main landing gear has two wheels and an oleo-pneumatic shock strut. Each wheel has a carbon brake.

The nose landing gear has two wheels, an oleo-pneumatic shock strut and nose wheel steering system.

When the landing gear is extended, the lock stay is straight. At this time, lock stay is held in the over center 5° position by the down lock springs and will not be destabilized by external disturbances. With the lock stay in the over center position, the landing gear is held in the down and locked position. The down lock release actuator overcomes the down lock spring force to move the lock stay from its over center and locked position, allowing the landing gear to be retracted.

3. Landing Gear Safety Pin-Down Locking

Applicable to : ALL

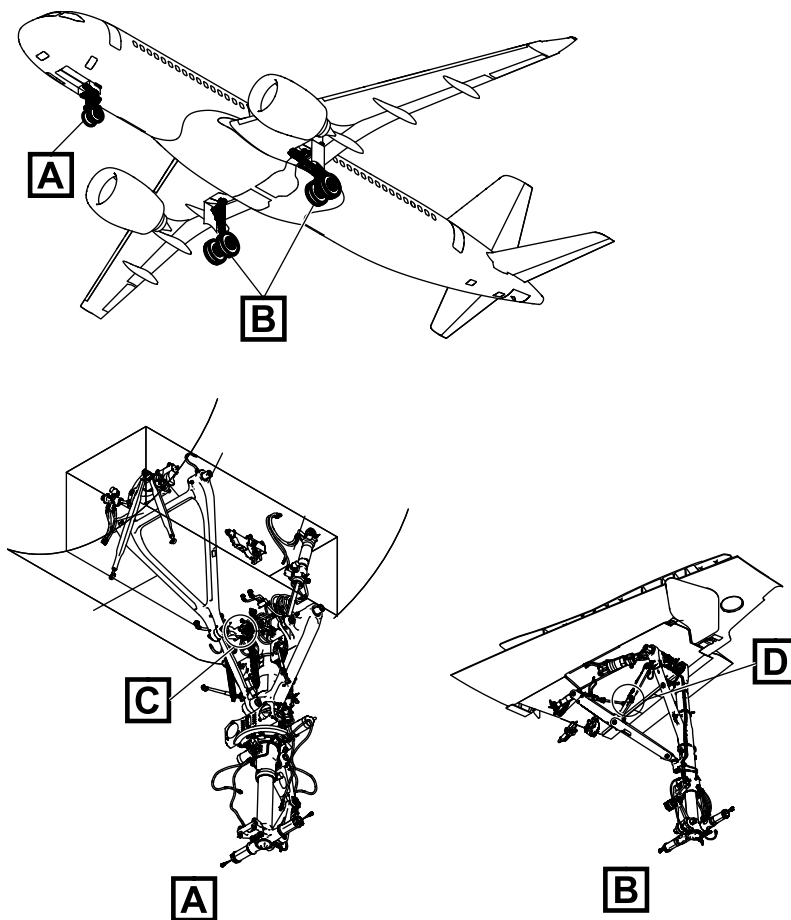

ICN-C919-A-192002-A-SVV19-70474-A-001-01

Figure 4 Landing gear safety pin - down locking (Sheet 1 of 2)

Applicable to : ALL

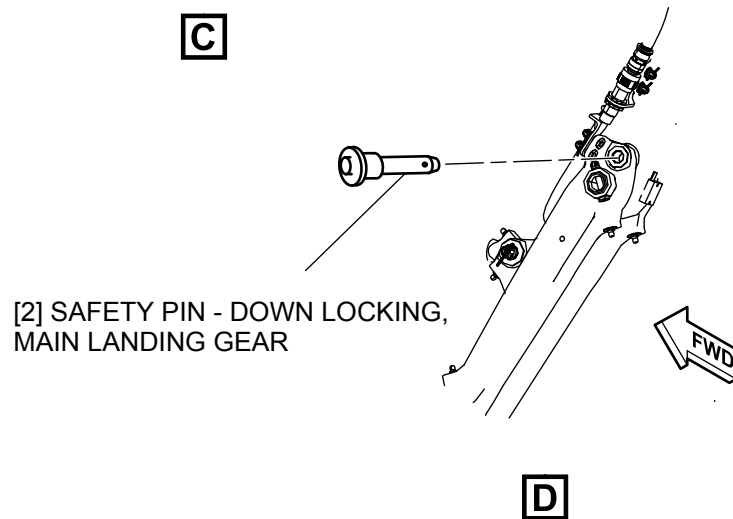
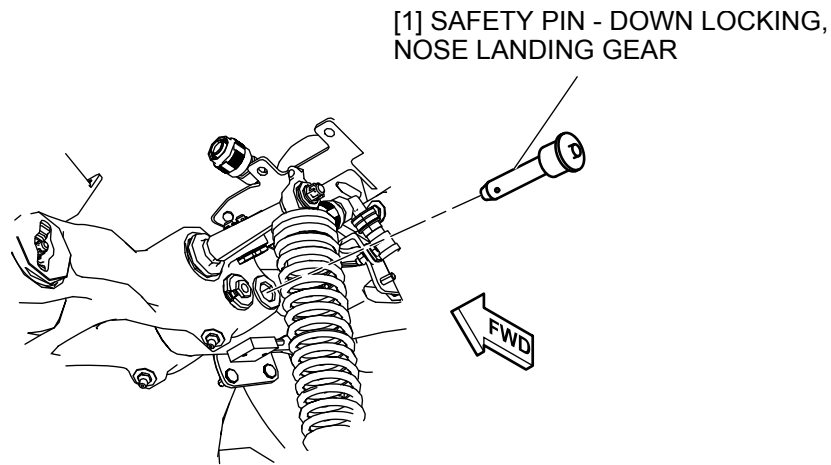

ICN-C919-A-192002-A-SVV19-70527-A-001-01

Figure 4 Landing gear safety pin - down locking (Sheet 2 of 2)

Intentionally left blank

Exterior Lighting

1. System Description

The exterior lights:

- Increase the visibility around the aircraft during operations and improve the flight crew's awareness.
- Enable the identification of the aircraft and its position.

Applicable to : ALL

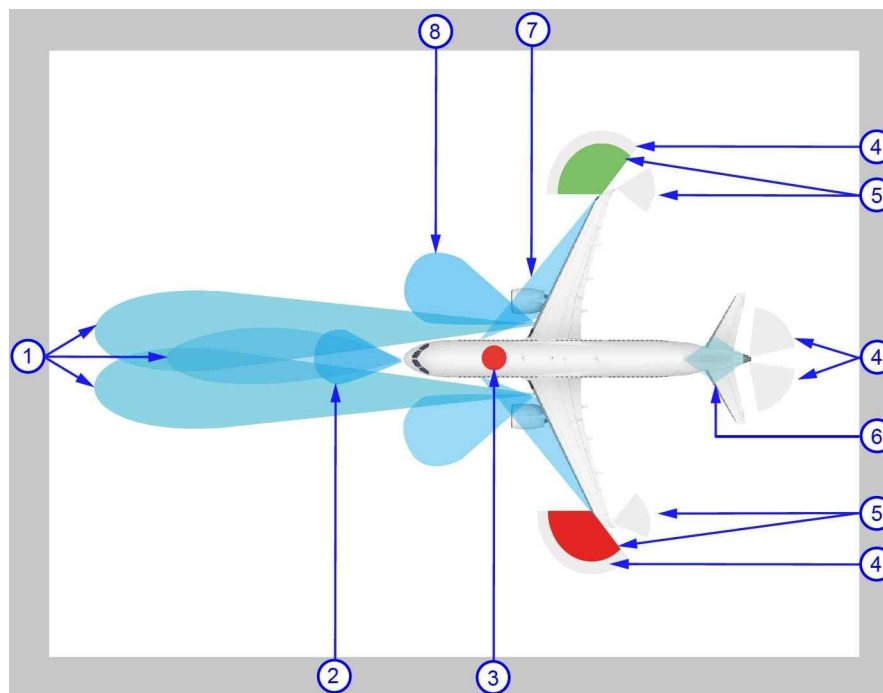

ICN-C919-A-170133-A-SVV19-11705-A-007-01

Figure 1 Exterior Lights (Sheet 1 of 1)

①	Landing lights	⑤	Navigation lights
②	Taxiing lights	⑥	Logo lights
③	Red Anti-Collision lights	⑦	Scan lights
④	White Anti-Collision lights	⑧	Runway turnoff lights

2. Landing Lights

Applicable to : ALL

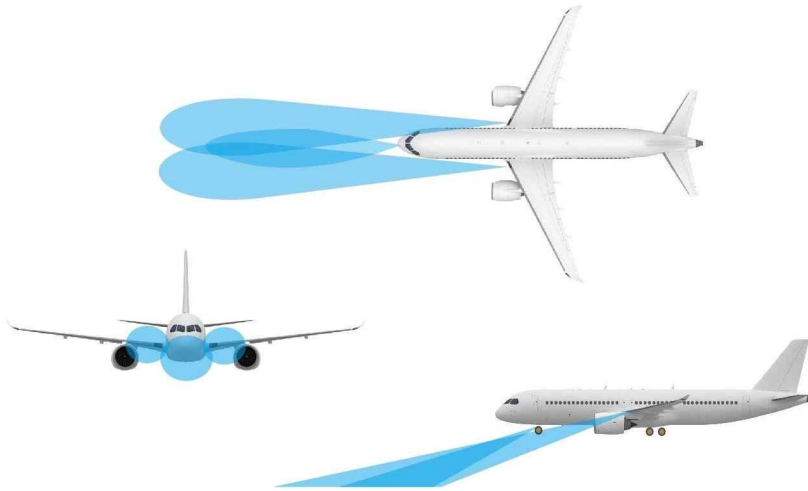

ICN-C919-A-170133-A-SVV19-33496-A-002-01

Figure 2 Landing Lights (Sheet 1 of 1)

Landing lights include two nose landing gear landing lights and two wing-root landing lights, which provide ground lighting during takeoff and landing.

3. Taxiing Lights

Applicable to : ALL

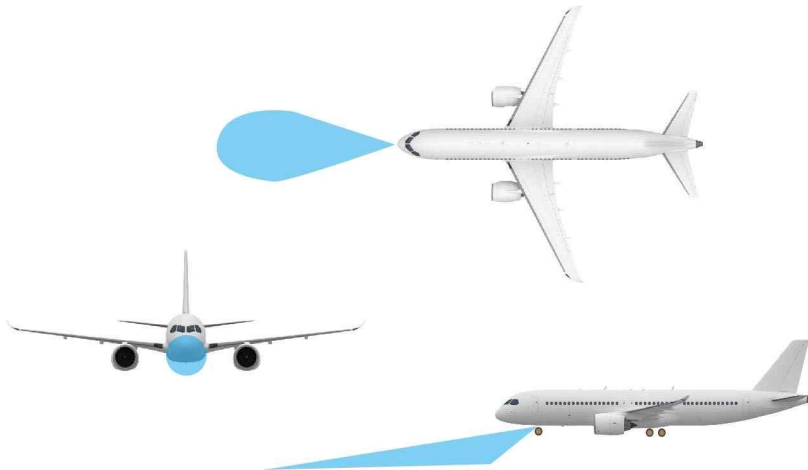

ICN-C919-A-170133-A-SVV19-33497-A-002-01

Figure 3 Taxiing Lights (Sheet 1 of 1)

Two taxiing lights that are used to provide ground lighting during takeoff and taxi. Taxiing lights, which are installed on the nose landing gear.

4. Red Anti-Collision Lights

Applicable to : ALL

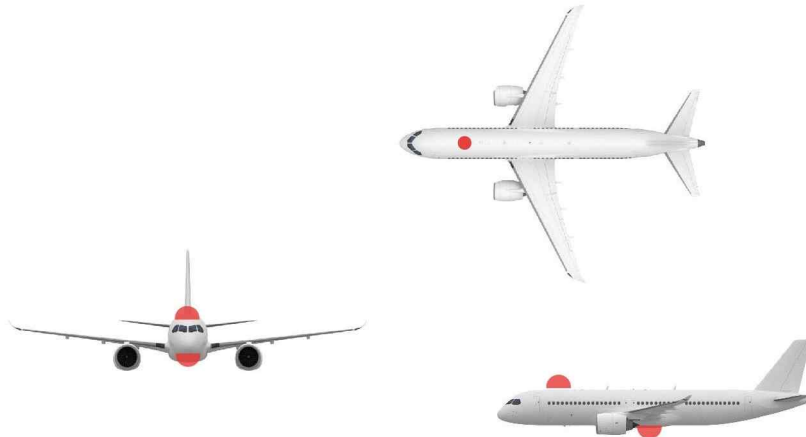

ICN-C919-A-170133-A-SVV19-33500-A-002-01

Figure 4 Red Anti-Collision Lights (Sheet 1 of 1)

Two red Anti-Collision lights are installed on aircraft top and belly, provide a red flashing light with high brightness, and are used to identify aircraft contour and to warn unconcerned personnel not to approach the aircraft during aircraft ground start.

5. White Anti-Collision Lights

Applicable to : ALL

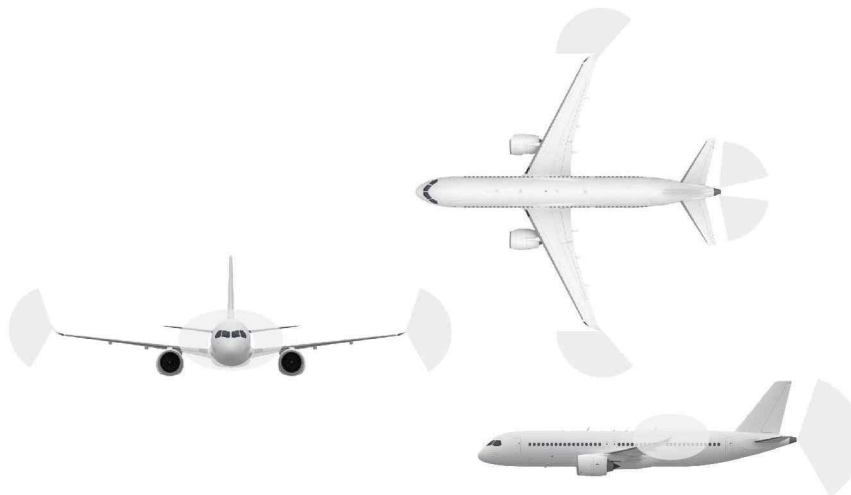

ICN-C919-A-170133-A-SVV19-33499-A-002-01

Figure 5 White Anti-Collision Lights (Sheet 1 of 1)

Four white Anti-Collision lights are installed on the leading edges of the left and right wingtips respectively, and the other two strobe lights on the left and right sides of APU compartment, provide a white flashing light with high brightness, and are used to identify aircraft contour.

Aircraft Characteristics for Airport Planning

6. Navigation Lights

Applicable to : ALL

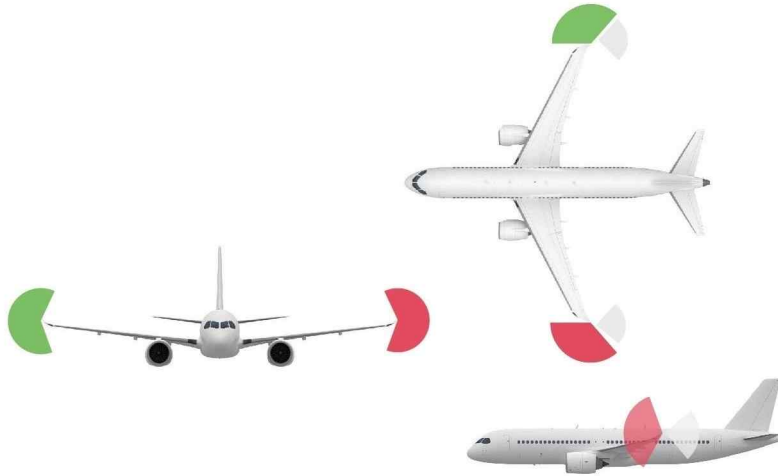

ICN-C919-A-170133-A-SVV19-33501-A-002-01

Figure 6 Navigation Lights (Sheet 1 of 1)

Navigation lights include one red light, one green light and two white navigation lights, which are used to display aircraft position and flight direction.

The red and green navigation lights are installed on the left and right wingtips respectively, and the two white navigation lights are respectively installed on the trailing edges of the left and right wingtips.

7. Logo Lights

Applicable to : ALL

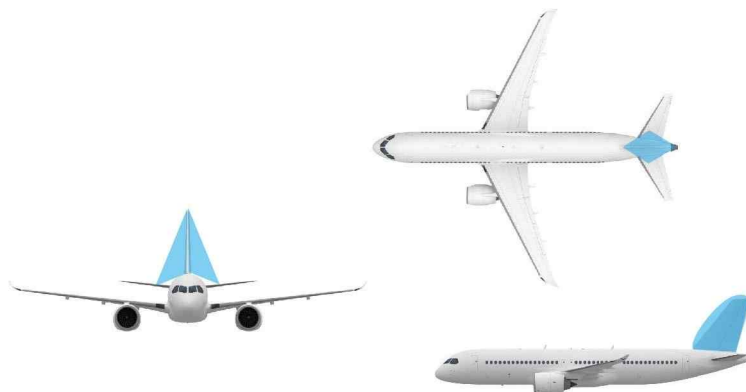

ICN-C919-A-170133-A-SVV19-33498-A-002-01

Figure 7 Logo Lights (Sheet 1 of 1)

Two logo lights that are used to illuminate the airlines logo on the vertical stabilizer. Logo lights are installed on the left and right horizontal stabilizers respectively.

8. Scan Lights

Applicable to : ALL

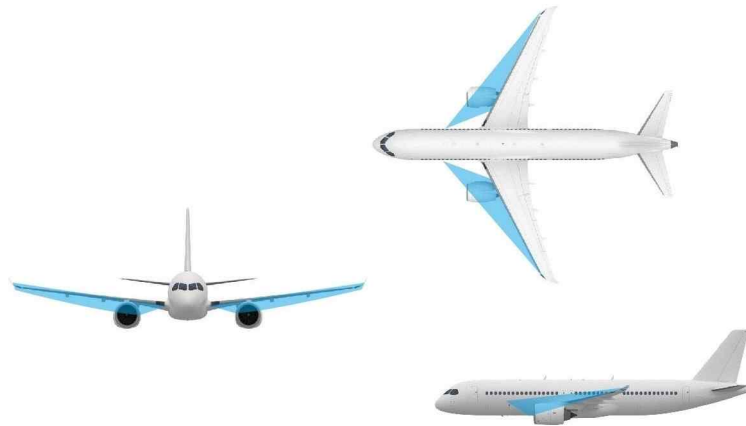

ICN-C919-A-170133-A-SVV19-33494-A-002-01

Figure 8 Scan Lights (Sheet 1 of 1)

Two scan lights that are used to illuminate the icing conditions on wing leading edges and engine nacelle to inspect the ice condition visually for the flight crew.

Scan lights are installed on the two sides of the fuselage.

9. Runway Turnoff Lights

Applicable to : ALL

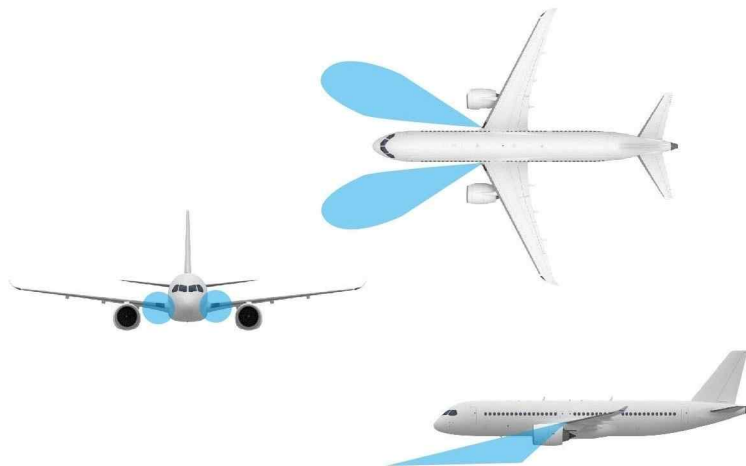

ICN-C919-A-170133-A-SVV19-33495-A-002-01

Figure 9 Runway Turnoff Lights (Sheet 1 of 1)

Two runway turnoff lights that are used to illuminate the front ground area to both sides of the aircraft, to provide the flight crew with a clearer view to detect aircraft taxiing beyond runway exits.

**Aircraft Characteristics for Airport
Planning**

Runway turnoff lights are installed at the left and right wing roots respectively.



Antenna Locations

Aircraft Characteristics for Airport Planning

Applicable to : ALL

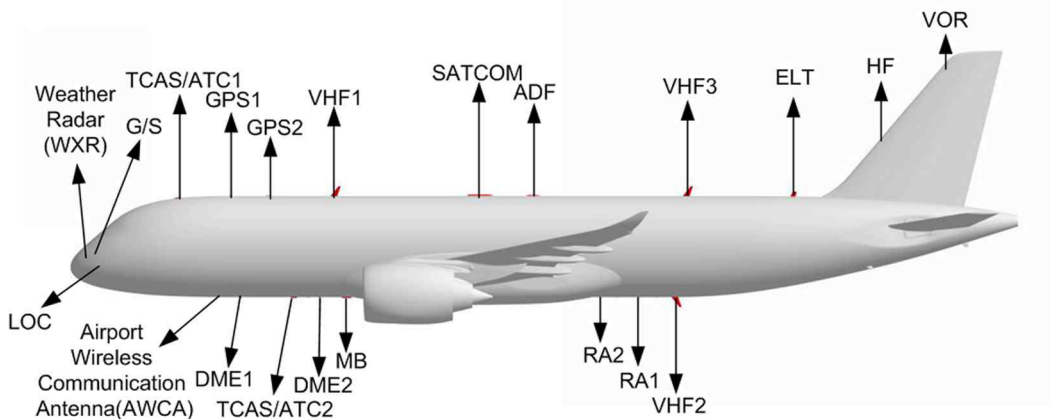

ICN-C919-A-170120-A-SVV19-12358-A-008-01

Figure 1 Antenna Locations (Sheet 1 of 1)

- NOTE:** The (VOR) antenna located on the vertical fin which is common with LOC antenna.
- NOTE:** Glide (G/S) antenna and heading (LOC) antenna are located in the radome.
- NOTE:** The (HF) antenna is installed at the leading edge of the vertical stabilizer, and the (VOR) antenna is installed at the top of the tail.

Table 1 Fuselage exterior antenna

Serial number	Antenna	Antenna name	Receiving/Transmitting character
1	GS	Sliding antenna	Receiving
2	LOC	Heading antenna	Receiving
3	GPS1	GPS antenna -1	Receiving
4	GPS2	GPS antenna -2	Receiving
5	R/A1、 R/A2	Radio altimeter antenna	Receiving /transmitting
6	WXR	Weather radar antenna	Receiving /transmitting
7	TCAS/ATC1	TCAS antenna -1	Receiving /transmitting
8	TCAS/ATC2	TCAS antenna -2	Receiving /transmitting
9	VOR	VHF Omni-directional range	Receiving
10	MB	Marker beacon antenna	Receiving
11	ADF	Automatic directional instrument antenna	Receiving
12	DME1	Distance measurement antenna 1	Receiving /transmitting
13	DME2	Distance measurement antenna 2	Receiving /transmitting



Aircraft Characteristics for Airport Planning

14	VHF1	Very high frequency antenna 1	Receiving /transmitting
15	VHF2	Very high frequency antenna 2	Receiving /transmitting
16	VHF3	Very high frequency antenna 3	Receiving /transmitting
17	SATCOM	Satellite communications	Receiving /transmitting
18	ELT	Emergency locator transmitter	transmitting
19	AWCA	Airport wireless communication antenna	Receiving /transmitting

Applicable to : ALL

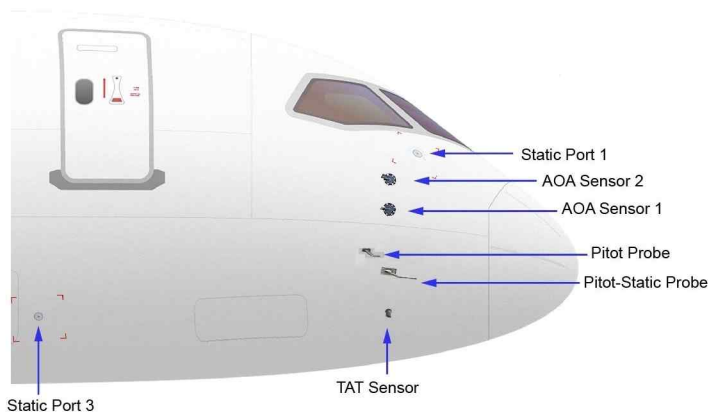

ICN-C919-A-192002-A-SVV19-78595-A-001-01

Figure 2 Air Data Sensor (Sheet 1 of 1)

NOTE: The positions of the air data sensors on the left and right sides of the aircraft are symmetrical.

Intentionally left blank

Power Plant

1. Auxiliary Power Unit(APU)

A. General

APU is a gas turbine. It mainly has following functions:

- On the ground : provide bleed air for the environmental control system and main engine start below 1124.7m(3,690ft), and provide shaft power for the generator below 1124.7m(3,690ft).
- In the air :
 - Provide shaft power for the generator under 12131m(39,800ft) .
 - Provide bleed air for the environmental control system below 6096m(20,000ft) .
 - Under 6096m(20,000ft), when the dual engine fails, you can try (but do not guarantee the ability to start the engine) using APU to start the engine.
- Provides electric power to the electrical system.

B. Controls

The primary APU controls and indications are installed on the overhead panel and on the instrument panel.

2. Engine

A. General

The aircraft power unit has two turbofan engine LEAP-1C produced by CFM company, and is installed under the wings on both sides of the aircraft.

The engine components include:

- Fan and low pressure compressor/turbine module
- High pressure compressor/turbine module
- Combustion chamber
- Accessory gearbox

B. Parameter

Maximum thrust takeoff (ISA): C919 STD 28468 lb and C919 ER 30000 lb

Fan Diameter: 78 in

Show to station: 6126 mm

Nacelle injection quantity: 2.02%

Nacelle runner height: 11.42%

On the elevation: 1.5%

In the Angle: 1.65%

Aircraft Characteristics for Airport Planning

Applicable to : ALL

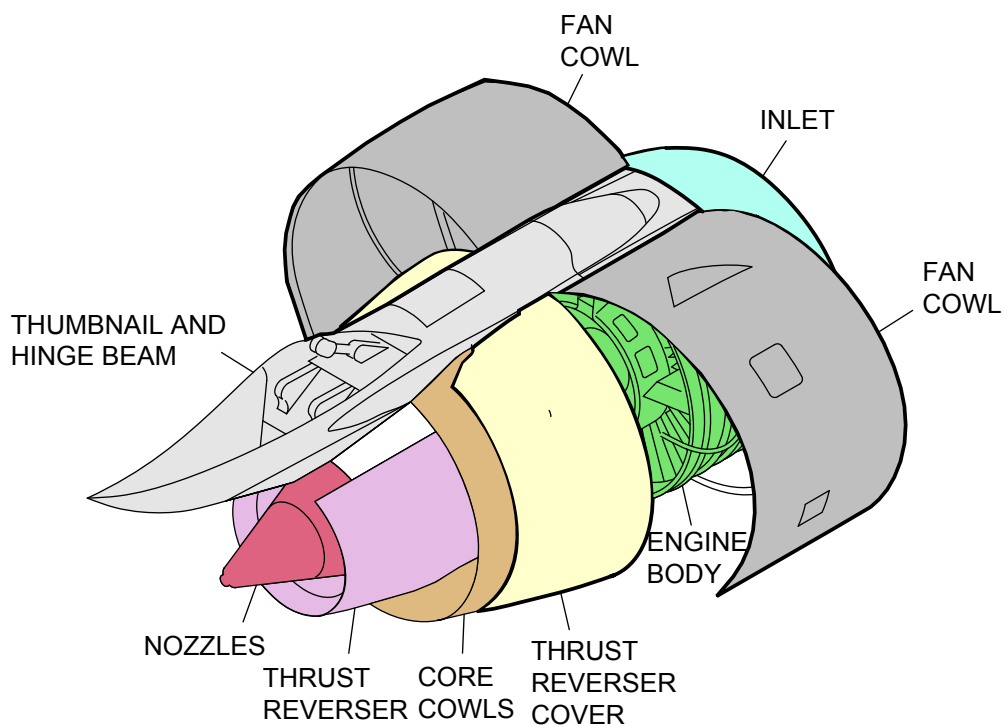
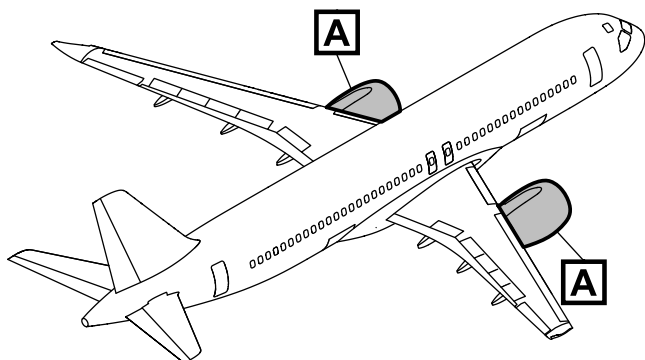

ICN-C919-A-192002-A-SVV19-78458-A-001-01

Figure 1 Engine structure (Sheet 1 of 1)

Intentionally left blank

Leveling/Weighting

1. Quick leveling

Quick leveling of the C919 accomplished by 2 basic methods.

Utilization of gage tool inclinometer, the level precision is within 0.5 degree.

Utilization of plumb, operate steps same as inclinometer, the leveling precision of plumb is within 0.25 degree.

2. Weighting

You can weigh the airplane with one of the following two procedures: Weigh the airplane with platform scales (without leveling), weigh the airplane at the wing and fuselage jacking points (leveling).

To weigh the aircraft on jacks, the aircraft must have a pitch attitude of zero degree, you can do this procedure with load cells on each jack or with platform scales under each jack.

3. Ground Support Equipment

- Quick leveling tool plumb
- Platforms - Weighing, Aircraft

Intentionally left blank

Jacking

1. Description

The jacking points are designed for aircraft maintenance and changing of tires.

The jacking points are divided into fuselage jacking points and airplane axles jacking points according to different purposes.

2. Jacking Airplane

A. Description

The airplane is provided with three main jacking points and one auxiliary jacking point, Table 1 Jacking point locations and maximum loads - Fuselage, Figure 1 Jacking point locations - Fuselage.

The main jacking points are forward jacking point A and two wing jacking points B, C. The auxiliary jacking point is aft body jacking point D.

B. Jacking specifications

Table 1 Jacking point locations and maximum loads - Fuselage. The maximum jack loads listed for each jack point are the maximum load that may be applied to that airplane. These loads will not be exceeded during jacking of the airplane. It is normal practice to select jacks with lifting capacity equal to or greater than the maximum load allowed for the airplane jack point.

Table 1 Table 1 Jacking point locations and maximum loads - Fuselage

Jacking Points - Fuselage		Jacking Point Locations (Meters)			Jacking Loads (Kg)
		X	Y	Z	
Main Jacking Points	A	6.338	-2.035	0	5430
	B	21.759	-0.934	-5.579	31045
	C	21.759	-0.934	5.579	31045
Auxiliary Jacking Point	D	35.35	-1.282	0	2000

3. Jacking Airplane Axles

The three landing gear jacking points are points B at each main gear axle and point A under the nose gear axle, Figure 1 Jacking point locations - Airplane axles. The axle jacking points are designed to permit the changing of two flat tires on the same landing gear while the airplane is at maximum taxi weight. The maximum load on an axle jacking point must not be exceeded, Table 1 Jacking point locations and maximum loads - Airplane axles.

Table 2 Table 1 Jacking point locations and maximum loads - Airplane axles

Jacking Points - Airplane Axles		Jacking Point Locations (Meters)			Jacking Loads (Kg)
		X	Y	Z	
Nose Landing Gear	A	8.868	-4.012	0	9607



**Aircraft Characteristics for Airport
Planning**

Main Landing Gear	B (Left)	22.327	-4.009	3.81	36945
	B (Right)	22.327	-4.009	-3.81	36945

Chapter 03

Aircraft Performance

Intentionally left blank

contents

<u>Document title</u>	<u>Data module code</u>	<u>Number of pages</u>	<u>Applicable to</u>
03 Aircraft Performance			
General Information	C919-A-19-20-03-01A-03CA-A	1	ALL
Payload/Range	C919-A-19-20-03-02A-03CA-A	1	ALL
Takeoff Runway Length	C919-A-19-20-03-03A-03CA-A	1	ALL
Landing Field Length	C919-A-19-20-03-04A-03CA-A	1	ALL
Landing Reference Speed	C919-A-19-20-03-05A-03CA-A	1	ALL

Intentionally left blank



General Information - Performance

Standard day temperatures for the altitudes shown are tabulated below :

Table 1 Altitude-temperature Transfer (ISA)

Altitude		Standard Day Temperature	
FT	M	°F	°C
0	0	59.0	15.0
2000	610	51.9	11.1
4000	1219	44.7	7.1
6000	1829	37.6	3.1
8000	2438	30.5	-0.8
10000	3048	23.3	-4.7
12000	3658	12.6	-10.8
14000	4267	9.1	-12.7
15000	4572	5.5	-14.7

Intentionally left blank

Payload/Range - Performance

This section give the payload/range at ISA.

Table 1 Payload/Range of C919

C919	C919 STD		C919 ER	
	Range(NM)	Payload(KG)	Range(NM)	Payload(KG)
Maximum Payload	1420	18900	2118	18900
Standard Payload	2235	15010	3011	15010
Maximum Fuel	3347	9930	3227	13730
Minimum Payload	3720	0	3723	0

Applicable to : ALL

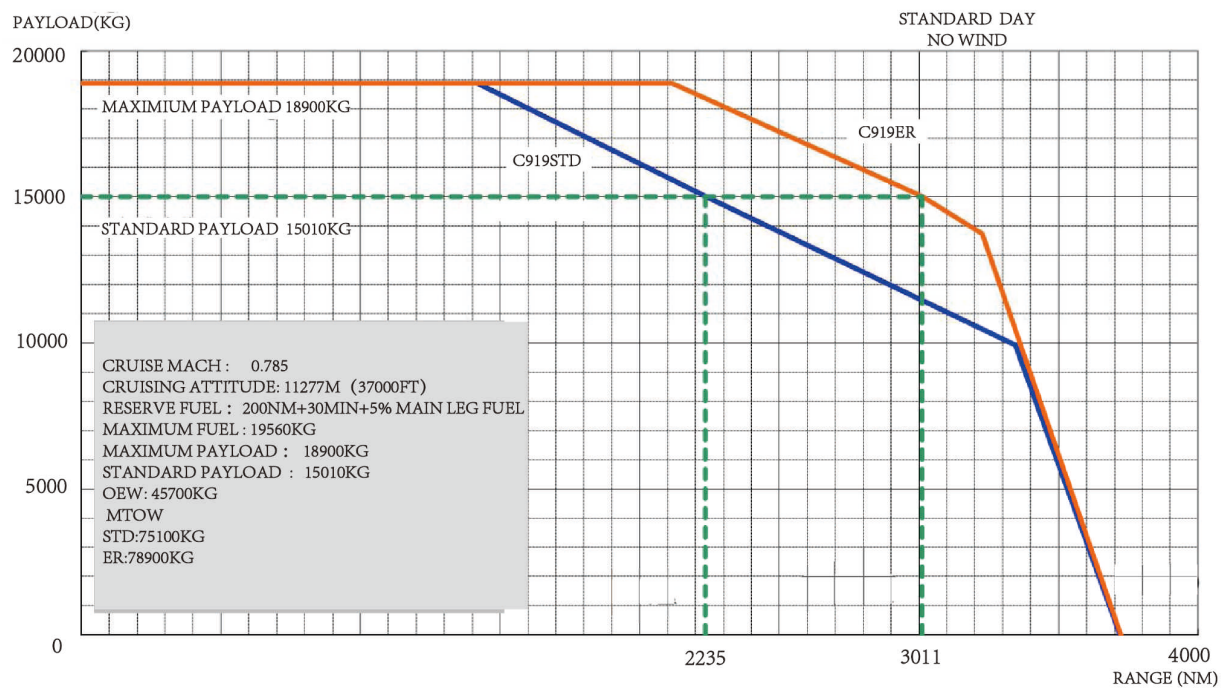

ICN-C919-A-000000-A-SVV19-10714-A-002-01

Figure 1 Payload/Range of C919 (Sheet 1 of 1)

Intentionally left blank

Takeoff Runway Length - Performance

Takeoff performance table give out the takeoff distance of C919 at different kind of airport pressure altitudes and temperatures.

Table 1 Takeoff Distance of C919 STD-Config 1+F ,Unit:m

Weight (KG)	ISA	ISA+10	ISA+20	ISA+30	ISA	ISA+10	ISA+20	ISA+30
	Airport Pressure Altitude = SL				Airport Pressure Altitude = 1000M			
60000	1388	1426	1530	1713	1509	1555	1663	1859
62000	1465	1508	1619	1815	1593	1639	1759	1972
64000	1545	1591	1710	1924	1682	1732	1858	2090
66000	1630	1676	1803	2038	1772	1825	1963	2212
68000	1716	1767	1902	2157	1869	1925	2068	2341
70000	1806	1859	2006	2286	1965	2027	2184	2481
72000	1900	1956	2112	2427	2068	2132	2300	2624
74300	2014	2072	2241	2658	2191	2259	2440	2824
75100	2052	2115	2288	2755	2235	2305	2491	2918
	Airport Pressure Altitude = 2000M				Airport Pressure Altitude = 2500M			
60000	1697	1748	1845	2064	1871	1930	2002	2235
62000	1795	1849	1957	2192	1979	2041	2121	2375
64000	1896	1958	2066	2327	2092	2156	2243	2522
66000	2004	2066	2185	2468	2208	2278	2373	2678
68000	2114	2180	2307	2615	2330	2406	2511	2843
70000	2229	2298	2432	2774	2460	2540	2651	3024
72000	2349	2424	2566	2945	2592	2677	2799	3241
74300	2491	2572	2725	3191	2753	2844	2979	-
75100	2538	2620	2783	3313	2816	2903	3049	-

Table 2 Takeoff Distance of C919 STD—Config2, Unit:m

Weight (KG)	ISA	ISA+10	ISA+20	ISA+30	ISA	ISA+10	ISA+20	ISA+30
	Airport Pressure Altitude = SL				Airport Pressure Altitude = 1000M			
60000	1326	1364	1464	1646	1439	1482	1588	1782
62000	1401	1440	1549	1750	1521	1567	1681	1896
64000	1479	1521	1637	1861	1607	1653	1777	2013
66000	1561	1606	1731	1995	1695	1746	1878	2142
68000	1646	1692	1830	2183	1788	1843	1984	2304
70000	1736	1786	1933	2432	1886	1943	2098	2542
72000	1830	1881	2046	-	1987	2046	2220	-
74300	1944	2000	2204	-	2111	2173	2367	-

Applicable to: ALL

03-03

Issue 001, 2022-10-20

Page 1 of 4



Aircraft Characteristics for Airport Planning

75100	1985	2042	2274	-	2156	2221	2425	-
	Airport Pressure Altitude = 2000M				Airport Pressure Altitude = 2500M			
60000	1619	1669	1762	1980	1783	1841	1909	2146
62000	1714	1765	1867	2106	1890	1950	2024	2287
64000	1811	1869	1977	2243	2002	2064	2148	2444
66000	1915	1977	2092	2392	2120	2184	2277	2648
68000	2026	2088	2212	2586	2242	2314	2415	-
70000	2140	2204	2341	-	2373	2445	2562	-
72000	2258	2329	2478	-	2512	2589	2726	-
74300	2410	2484	2651	-	2699	2770	-	-
75100	2457	2530	2721	-	2793	2863	-	-

Table 3 Takeoff Distance of C919 STD—Config3, Unit:m

Weight (KG)	ISA	ISA+10	ISA+20	ISA+30	ISA	ISA+10	ISA+20	ISA+30
	Airport Pressure Altitude = SL				Airport Pressure Altitude = 1000M			
60000	1243	1278	1406	1585	1350	1394	1525	1714
62000	1346	1385	1489	1690	1461	1504	1614	1825
64000	1422	1461	1576	1801	1544	1590	1709	1943
66000	1501	1542	1668	1968	1630	1679	1807	2077
68000	1585	1629	1762	2191	1720	1771	1911	2292
70000	1670	1719	1867	-	1815	1867	2021	-
72000	1761	1813	1980	-	1914	1969	2142	-
74300	1875	1929	2182	-	2035	2097	2310	-
75100	1918	1971	2273	-	2079	2141	2399	-
	Airport Pressure Altitude = 2000M				Airport Pressure Altitude = 2500M			
60000	1555	1603	1692	1906	1716	1770	1834	2067
62000	1646	1697	1796	2031	1819	1876	1949	2208
64000	1741	1795	1900	2165	1930	1991	2065	2378
66000	1843	1897	2011	2329	2044	2107	2195	2682
68000	1948	2009	2131	2605	2165	2233	2329	-
70000	2059	2122	2256	-	2297	2369	2481	-
72000	2179	2244	2394	-	2448	2514	2711	-
74300	2329	2399	2609	-	-	-	-	-
75100	2378	2451	2731	-	-	-	-	-

Table 4 Takeoff Distance of C919 ER—Config 1+F ,Unit:m

Weight (KG)	ISA	ISA+10	ISA+20	ISA+30	ISA	ISA+10	ISA+20	ISA+30
	Airport Pressure Altitude = SL				Airport Pressure Altitude = 1000M			
60000	1325	1364	1456	1621	1478	1522	1628	1813
62000	1399	1440	1537	1715	1562	1610	1721	1921
64000	1472	1518	1622	1816	1646	1696	1817	2034
66000	1551	1597	1711	1918	1735	1787	1916	2152
68000	1632	1680	1800	2026	1825	1883	2021	2275
70000	1715	1766	1895	2137	1922	1980	2128	2406
72000	1804	1855	1991	2256	2021	2082	2242	2542
74300	1904	1964	2109	2398	2140	2205	2375	2712
76000	1982	2044	2200	2512	2229	2299	2481	2845
78900	2125	2190	2362	2758	2392	2467	2668	3202
	Airport Pressure Altitude = 2000M				Airport Pressure Altitude = 2500M			
60000	1697	1748	1846	2063	1870	1930	2000	2231
62000	1795	1849	1952	2192	1979	2041	2118	2369
64000	1896	1958	2063	2324	2090	2159	2240	2518
66000	2004	2066	2182	2468	2208	2277	2369	2672
68000	2114	2180	2302	2614	2329	2405	2505	2837
70000	2229	2298	2428	2773	2457	2539	2648	3016
72000	2349	2424	2563	2944	2591	2676	2795	3227
74300	2491	2572	2721	3191	2752	2843	2973	-
76000	2604	2689	2844	-	2880	2973	3116	-
78900	2806	2895	3073	-	3108	3211	3383	-

Table 5 Takeoff Distance of C919 ER—Config2, Unit:m

Weight (KG)	ISA	ISA+10	ISA+20	ISA+30	ISA	ISA+10	ISA+20	ISA+30
	Airport Pressure Altitude = SL				Airport Pressure Altitude = 1000M			
60000	1209	1244	1389	1552	1397	1438	1554	1734
62000	1320	1358	1468	1646	1489	1533	1643	1842
64000	1408	1449	1549	1742	1572	1618	1735	1955
66000	1481	1526	1636	1847	1657	1707	1834	2076
68000	1562	1605	1724	1958	1748	1800	1936	2203
70000	1642	1690	1816	2074	1841	1895	2042	2355
72000	1725	1778	1913	2236	1937	1995	2157	2586
74300	1829	1880	2033	2492	2055	2114	2293	-
76000	1906	1961	2125	-	2147	2209	2403	-

Applicable to: ALL

03-03

Issue 001, 2022-10-20

Page 3 of 4



Aircraft Characteristics for Airport Planning

78900	2049	2108	2296	-	2313	2383	2651	-
	Airport Pressure Altitude = 2000M				Airport Pressure Altitude = 2500M			
60000	1619	1669	1759	1977	1783	1841	1907	2141
62000	1714	1765	1865	2107	1890	1950	2025	2282
64000	1811	1869	1975	2242	2002	2064	2144	2438
66000	1915	1977	2089	2391	2120	2184	2272	2631
68000	2026	2088	2208	2585	2242	2313	2411	-
70000	2140	2204	2336	-	2373	2445	2557	-
72000	2258	2329	2473	-	2512	2586	2719	-
74300	2410	2484	2646	-	-	-	-	-
76000	2530	2609	2815	-	-	-	-	-
78900	-	-	-	-	-	-	-	-

Table 6 Takeoff Distance of C919 ER—Config3, Unit:m

Weight (KG)	ISA	ISA+10	ISA+20	ISA+30	ISA	ISA+10	ISA+20	ISA+30
	Airport Pressure Altitude = SL				Airport Pressure Altitude = 1000M			
60000	1130	1158	1333	1493	1284	1322	1492	1670
62000	1217	1251	1410	1585	1412	1454	1578	1774
64000	1334	1372	1490	1679	1511	1554	1668	1885
66000	1424	1466	1573	1781	1592	1639	1764	2001
68000	1500	1543	1657	1889	1678	1728	1860	2129
70000	1577	1625	1747	2027	1768	1821	1967	2338
72000	1660	1707	1841	2225	1861	1918	2077	-
74300	1760	1809	1958	-	1977	2036	2212	-
76000	1836	1888	2049	-	2067	2130	2324	-
78900	1976	2031	2254	-	2234	2301	-	-
	Airport Pressure Altitude = 2000M				Airport Pressure Altitude = 2500M			
60000	1555	1603	1690	1905	1716	1770	1833	2063
62000	1646	1697	1793	2028	1819	1876	1945	2203
64000	1741	1795	1896	2162	1928	1989	2066	2367
66000	1843	1897	2007	2324	2044	2107	2191	2659
68000	1948	2009	2128	2597	2164	2231	2325	-
70000	2059	2122	2251	-	2297	2369	2475	-
72000	2179	2244	2389	-	2448	2514	2695	-
74300	2329	2399	2597	-	-	-	-	-
76000	2487	2546	-	-	-	-	-	-
78900	-	-	-	-	-	-	-	-

Landing Field Length - Performance

1. Required Landing Distance

The required landing distance on a dry runway is the demonstrated landing distance divided by 0.6.

On a wet runway, the required landing distance is the required landing distance calculated for the dry runway multiplied by 1.15.

On a contaminated runway, the required landing distance is the greater of:

-The required landing distance calculated for the dry runway multiplied by 1.15.

-The approved actual landing distance conformed on the contaminated runway multiplied by 1.15.

Before takeoff you must verify that the required landing distance is within the landing distance available (LDA) at the estimated maximum landing weight.

If the airplane has a fault that affects the landing distance pre-dispatch, the available landing distance must be equal to or longer than the required landing distance with the pre-dispatch fault.

2. USE

Select the table according to the landing flaps position, and obtain the Required Landing Distance depending on the landing weight and runway status. Then calculate the corrections according to the airport pressure altitude and wind speed.

3. Required Landing Distance Data Table

Flaps 3-C919 STD

Required Landing Distance for Flaps 3(m)								
Weight (1000kg)		45	50	55	60	65	70	75.1
Dry		1568	1644	1716	1787	1855	1935	2043
Wet		1803	1890	1974	2054	2133	2225	2350
Contaminated runway	Compact ed snow	1803	1890	1974	2054	2133	2225	2350
	Standing water or slush	1826	1968	2106	2241	2375	2530	2718
	Dry or Wet snow	1875	1977	2074	2168	2259	2364	2490
	Ice	3446	3569	3705	3849	3997	4168	4374



Aircraft Characteristics for Airport Planning

Correction of Required Landing Distance for Flaps 3			
Runway status	Altitude Correction		Wind Speed Correction
	Per 1000 ft above Sea Level		Per 5 kt Headwind/ Tailwind
Dry	+45		-45/+145
Wet	+50		-50/+170
Contaminated runway	Compacted snow	+50	-50/+170
	Standing water or slush	+85	-90/+310
	Dry or Wet snow	+60	-65/+220
	Ice	+115	-160/+550

Flaps 3-C919 ER

Required Landing Distance for Flaps 3(m)									
Weight (1000kg)	45	50	55	60	65	70	75	78.9	
Dry	1568	1644	1716	1787	1855	1935	2042	2133	
Wet	1803	1890	1974	2054	2133	2225	2348	2452	
Contaminated runway	Compacted snow	1803	1890	1974	2054	2133	2225	2348	2452
	Standing water or slush	1826	1968	2106	2241	2375	2530	2714	2859
	Dry or Wet snow	1875	1977	2074	2168	2259	2364	2488	2585
	Ice	3446	3569	3705	3849	3997	4168	4371	4530

Correction of Required Landing Distance for Flaps 3			
Runway status	Altitude Correction		Wind Speed Correction
	Per 1000 ft above Sea Level		Per 5 kt Headwind/ Tailwind
Dry	+45		-45/+145
Wet	+50		-50/+170
Contaminated runway	Compacted snow	+50	-50/+170
	Standing water or slush	+85	-90/+310
	Dry or Wet snow	+60	-65/+220
	Ice	+115	-160/+550

Flaps Detent FULL-C919 STD

Required Landing Distance for Flaps FULL(m)								
Weight (1000kg)	45	50	55	60	65	70	75.1	
Dry	1547	1623	1694	1764	1832	1911	2019	
Wet	1779	1866	1949	2029	2106	2197	2322	
Contaminated runway	Compacted snow	1779	1866	1949	2029	2106	2197	2322
	Standing water or slush	1779	1903	2031	2158	2284	2430	2605
	Dry or Wet snow	1823	1923	2018	2110	2201	2303	2426
	Ice	3233	3353	3486	3625	3769	3932	4128

Correction of Required Landing Distance for Flaps FULL			
Runway status	Altitude Correction	Wind Speed Correction	
	Per 1000 ft above Sea Level	Per 5 kt Headwind/Tailwind	
Dry	+45	-40/+145	
Wet	+50	-50/+165	
Contaminated runway	Compacted snow	+50	-50/+165
	Standing water or slush	+80	-85/+290
	Dry or Wet snow	+55	-65/+215
	Ice	+110	-150/+530

Flaps Detent FULL-C919 ER

Required Landing Distance for Flaps FULL(m)									
Weight (1000kg)	45	50	55	60	65	70	75	78.9	
Dry	1547	1623	1694	1764	1832	1911	2017	2107	
Wet	1779	1866	1949	2029	2106	2197	2319	2423	
Contaminated runway	Compacted snow	1779	1866	1949	2029	2106	2197	2319	2423
	Standing water or slush	1779	1903	2031	2158	2284	2430	2602	2737

**Aircraft Characteristics for Airport
Planning**

Required Landing Distance for Flaps FULL(m)									
Weight (1000kg)		45	50	55	60	65	70	75	78.9
	Dry or Wet snow	1823	1923	2018	2110	2201	2303	2424	2518
	Ice	3233	3353	3486	3625	3769	3932	4124	4275

Correction of Required Landing Distance for Flaps FULL			
Runway status	Altitude Correction	Wind Speed Correction	
	Per 1000 ft above Sea Level	Per 5 kt Headwind/ Tailwind	
Dry	+45	-40/+145	
Wet	+50	-50/+165	
Contaminated runway	Compacted snow	+50	-50/+165
	Standing water or slush	+80	-85/+290
	Dry or Wet snow	+55	-65/+215
	Ice	+110	-150/+530



Landing Reference Speed - Performance

Table 1 Landing Reference Speed (SL ,ISA), Unit:KCAS

Weight (KG)	V _{REF-3}	V _{REF-FULL}	Weight (KG)	V _{REF-3}	V _{REF-FULL}
45000	123.72		63000	138.35	
46000	124.66		64000	139.13	
47000	125.52		65000	139.82	
48000	126.45		66000	140.52	
49000	127.31		67000	141.21	
50000	128.17		67800	141.74	
51000	129.03		68000	141.98	
52000	129.89		69000	142.96	
53000	130.66		70000	144.02	
54000	131.52		71000	145.07	
55000	132.3		72000	146.05	
56000	133.08		73000	147.11	
57000	133.85		74000	148.08	
58000	134.63		75000	149.14	
59000	135.41		76000 (ER)	150.04	
60000	136.18		77000 (ER)	151.01	
61000	136.88		78900 (ER)	152.89	
62000	137.66				

Intentionally left blank

Chapter 04

Ground Maneuvering

Intentionally left blank

contents

<u>Document title</u>	<u>Data module code</u>	<u>Number of pages</u>	<u>Applicable to</u>
04 Ground Maneuvering			
General Information	C919-A-19-20-04-01A-04AA-A	1	ALL
Turning Radii, No Slip Angle	C919-A-19-20-04-02A-04AA-A	1	ALL
Minimum Turning Radium	C919-A-19-20-04-03A-04AA-A	1	ALL
Visibility from Cockpit in Static Position	C919-A-19-20-04-04A-04AA-A	1	ALL
Runway and Taxiway Turn Paths	C919-A-19-20-04-05A-04AA-A	1	ALL
Runway Holding Bay	C919-A-19-20-04-06A-04AA-A	1	ALL
Mooring	C919-A-19-20-04-07A-84AA-A	1	ALL

Intentionally left blank

General Information

This chapter provides aircraft turning capability and maneuvering characteristics on the ground.

For ease of presentation, these data have been determined from the theoretical limits imposed by the geometry of the aircraft. As such, they reflect the turning capability in favorable operating circumstances. These data should be used only as guidelines for the method of determination of such parameters and for the maneuvering characteristics of this aircraft.

Intentionally left blank

Turning Radii, No Slip Angle

Applicable to : ALL

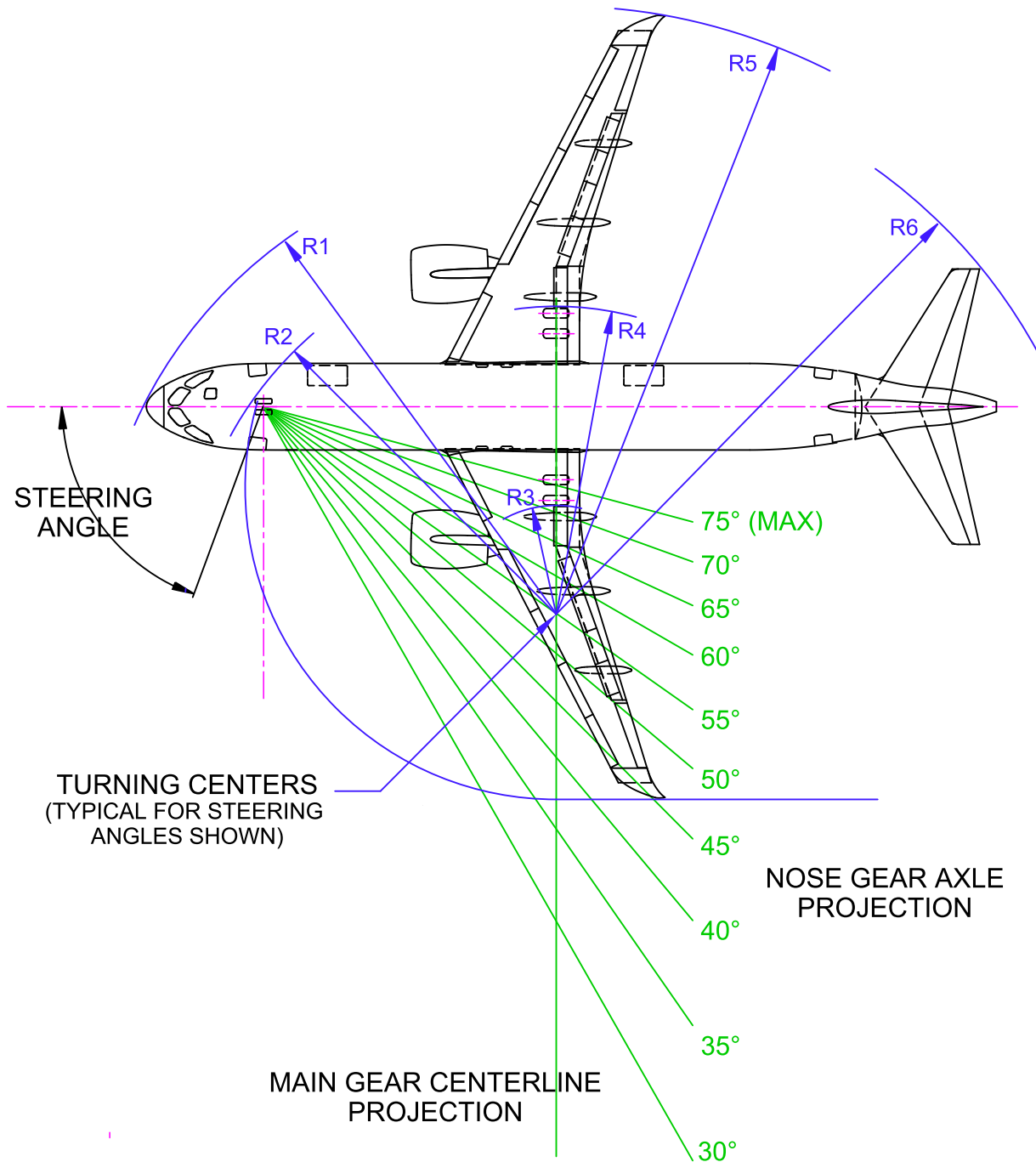

ICN-C919-A-192004-A-SVV19-21852-A-004-01

Figure 1 Turning Radii - No Slip Angle (Sheet 1 of 1)

NOTE: ACTUAL OPERATING TURNING RADII MAY BE GREATER THAN SHOWN.
CONSULT WITH AIRLINE FOR SPECIFIC OPERATING PROCEDURE.

**Aircraft Characteristics for Airport
Planning**
Table 1 Turning Radii Value

Steering Angle (Degrees)	R1 Nose		R2 Nose Gear		R3 Inner Gear		R4 Outer Gear		R5 Wing		R6 Tail	
	FT	M	FT	M	FT	M	FT	M	FT	M	FT	M
30	98.19	29.93	89.56	27.30	61.81	18.84	91.26	27.82	136. 25	41.53	116. 15	35.40
35	88.13	26.86	78.23	23.84	48.38	14.75	77.84	23.72	122. 93	37.47	105. 17	32.06
40	80.97	24.68	69.93	21.31	37.93	11.56	67.39	20.54	112. 58	34.31	97.06	29.58
45	75.74	23.09	63.68	19.41	29.46	8.98	58.92	17.96	104. 21	31.76	90.83	27.68
50	71.82	21.89	58.87	17.94	22.35	6.81	51.81	15.79	97.19	29.62	85.89	26.18
55	68.86	20.99	55.13	16.80	16.21	4.94	45.67	13.92	91.15	27.78	81.89	24.96
60	66.59	20.30	52.21	15.91	10.78	3.29	40.24	12.27	85.81	26.16	78.59	23.95
65	64.87	19.77	49.94	15.22	5.88	1.79	35.33	10.77	81.00	24.69	75.81	23.11
70	63.58	19.38	48.21	14.69	1.35	0.41	30.81	9.39	76.58	23.34	73.44	22.39
75	62.64	19.09	46.93	14.31	-2.89	-0.88	26.57	8.10	72.44	22.08	71.41	21.77

Minimum Turning Radii

Applicable to : ALL

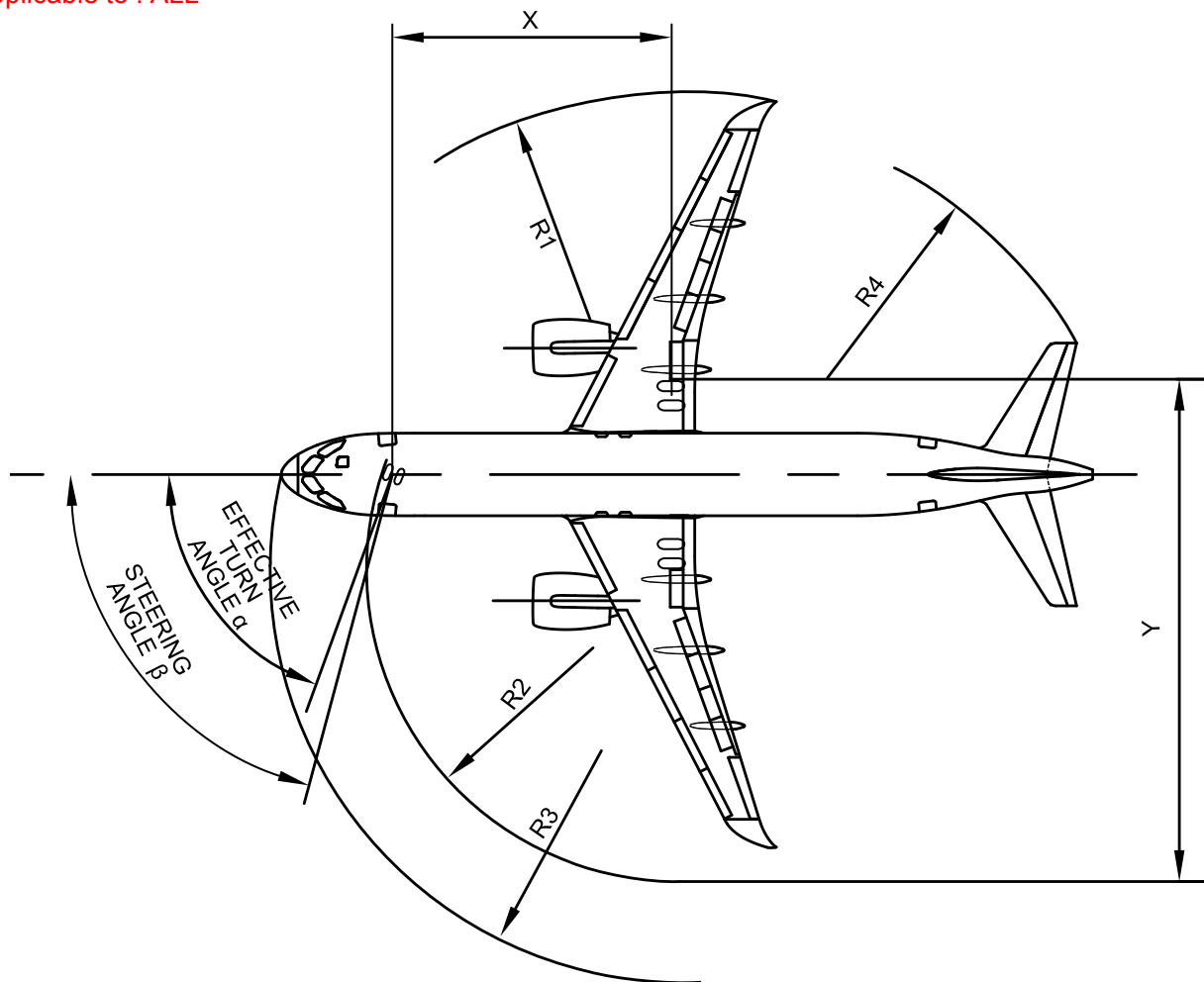

ICN-C919-A-192004-A-SVV19-10713-A-002-01

Figure 1 Minimum Turning Radii (Sheet 1 of 1)

Table 1 Minimum Turning Radil Value

α	β	X		Y		R1		R2		R3		R4	
		FT	M	FT	M	FT	M	FT	M	FT	M	FT	M
70°	75°	44.19	13.47	79.02	24.09	76.49	23.32	48.22	14.70	63.58	19.38	73.44	22.39

Intentionally left blank

Visibility from Cockpit in Static Position

Applicable to : ALL

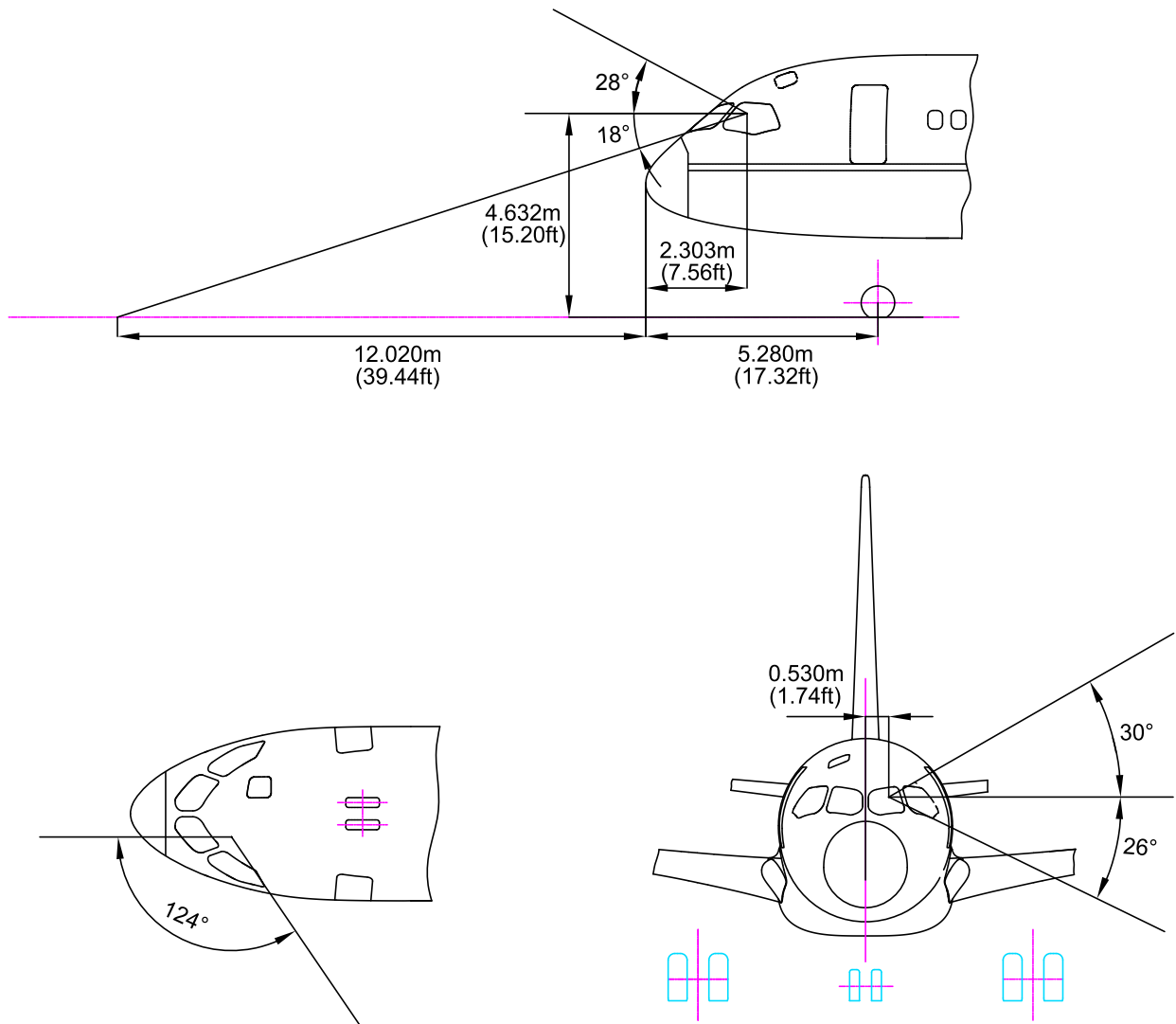

ICN-C919-A-192004-A-SVV19-21855-A-001-01

Figure 1 Visibility from Cockpit in Static Position (Sheet 1 of 1)

Intentionally left blank



Runway and Taxiway Turn Paths

1. Runway-to-Taxiway, 90 Degrees

Applicable to : ALL

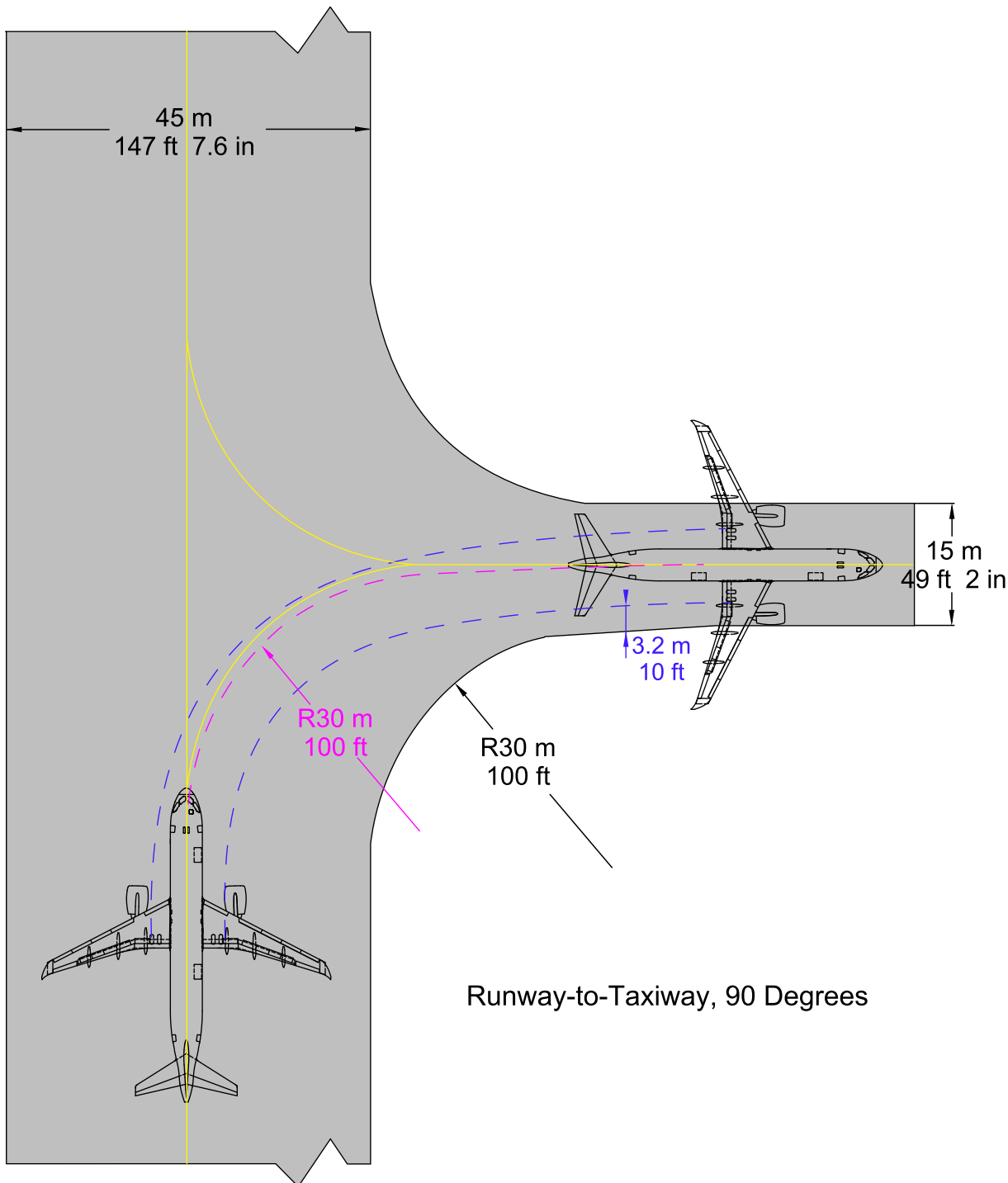

Runway-to-Taxiway, 90 Degrees

ICN-C919-A-192004-A-SVV19-21856-A-003-01

Figure 1 Runway-to-Taxiway, 90 Degrees (Sheet 1 of 1)

2. Runway-to-Taxiway, 135 Degrees

Applicable to : ALL

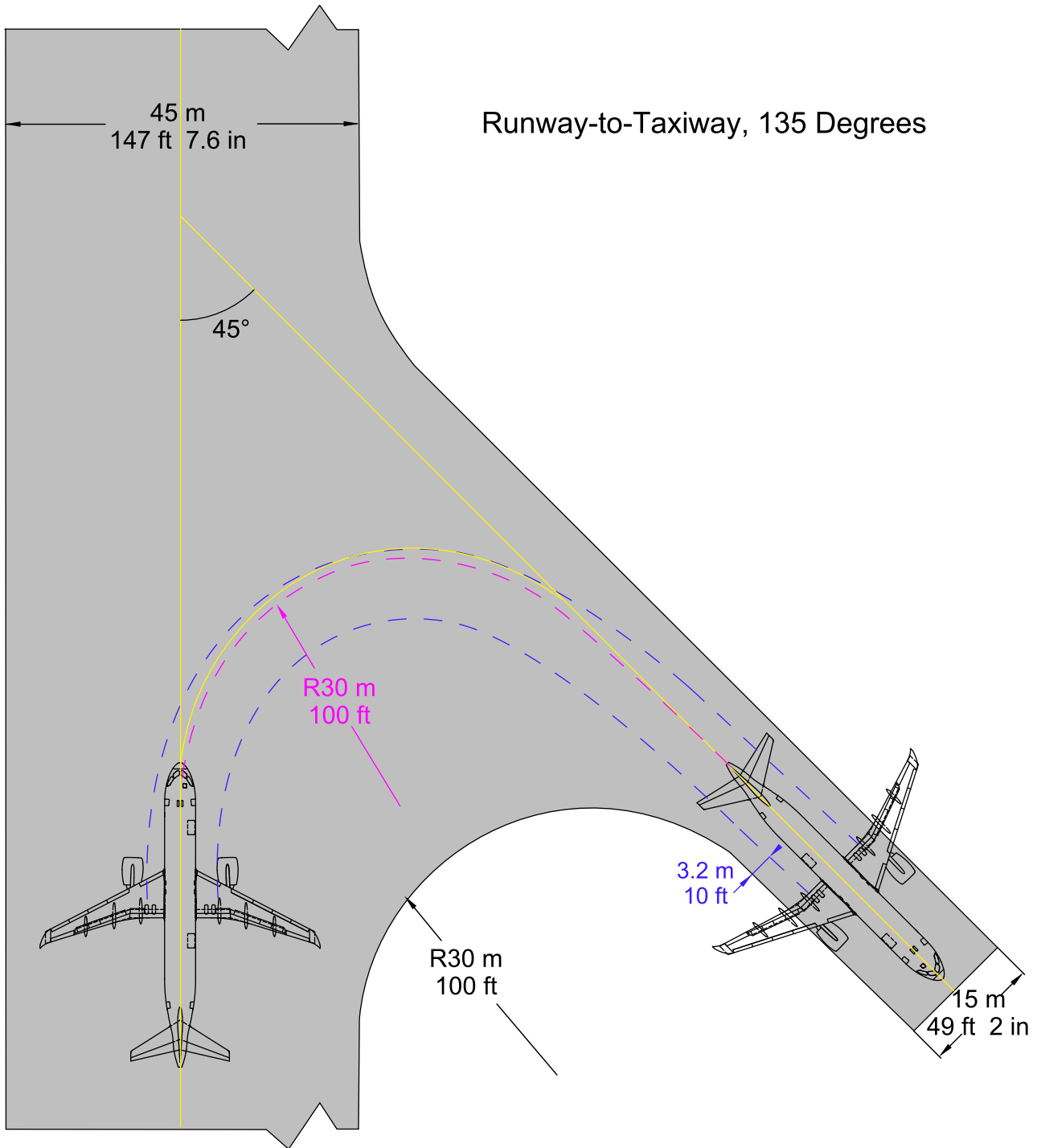

ICN-C919-A-192004-A-SVV19-21857-A-002-01

Figure 2 Runway-to-Taxiway, 135 Degrees (Sheet 1 of 1)

3. Taxiway-to-Taxiway, 90 Degrees

Applicable to : ALL

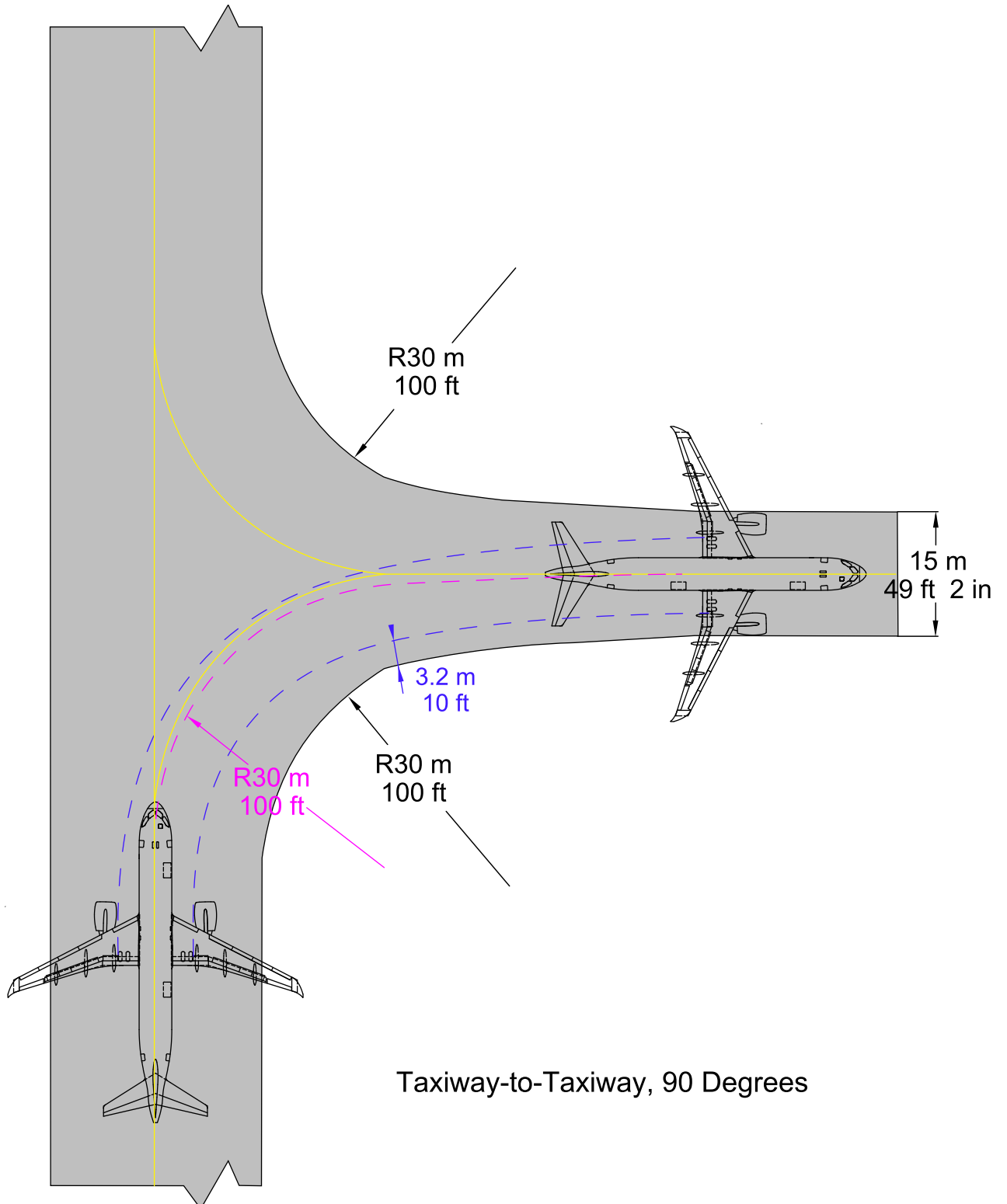

ICN-C919-A-192004-A-SVV19-21858-A-002-01

Figure 3 Taxiway-to-Taxiway, 90 Degrees (Sheet 1 of 1)

Intentionally left blank

Runway Holding Bay

Applicable to : ALL

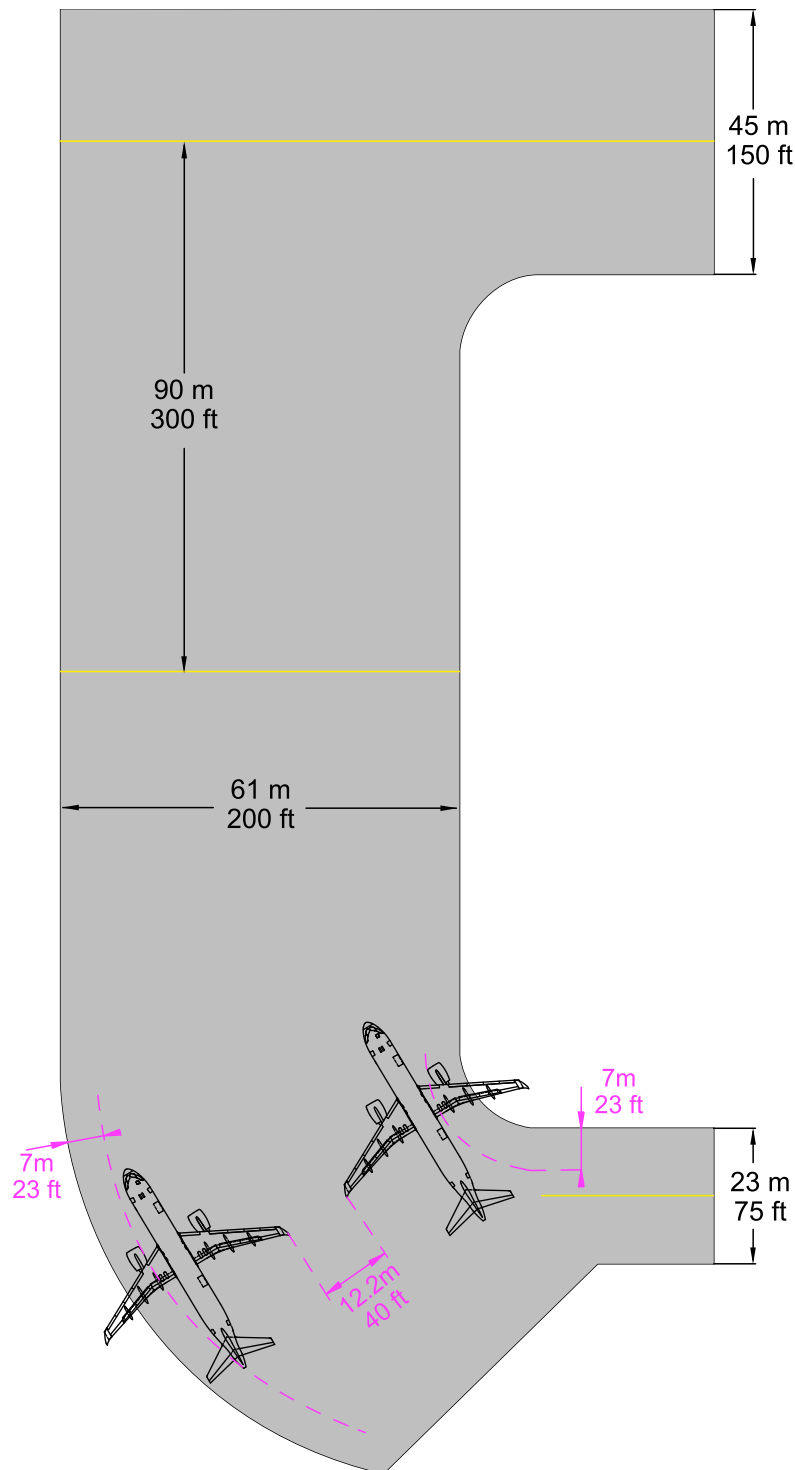

ICN-C919-A-192004-A-SVV19-21859-A-003-01

Figure 1 Runway Holding Bay (Sheet 1 of 1)

Intentionally left blank

Mooring

Description

Allowable mooring weight of aircraft

The minimum allowable mooring weight of aircraft is Operating Empty Weight (OEW). The maximum allowable mooring weight of aircraft is Maximum Design Taxi Weight (MTW).

Normal mooring ground anchor areas

The aircraft adopts the first three-point mooring from of nose landing gear mooring point and main landing gear mooring point. The ground anchor arrangement is as follows:

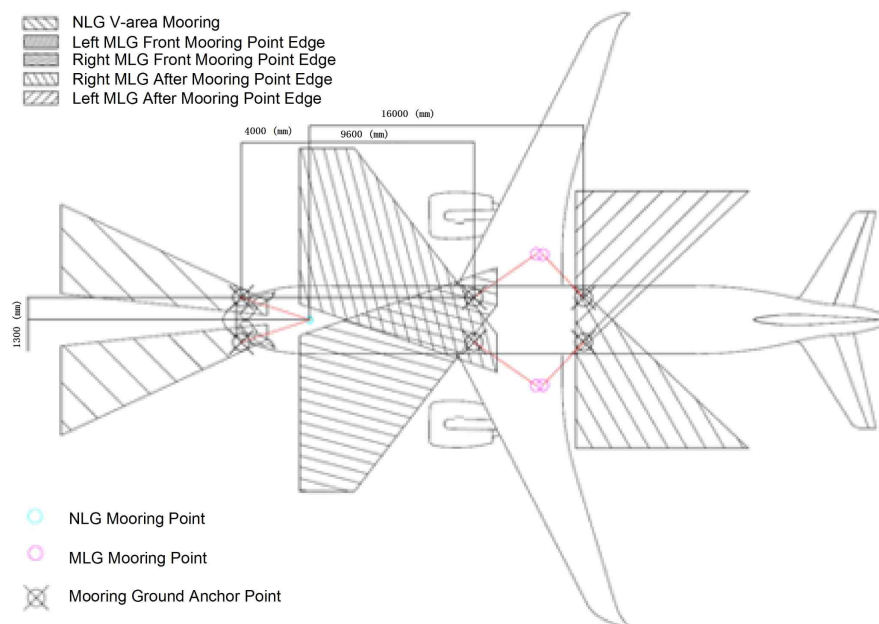

ICN-C919-A-192002-A-SVV19-65665-A-002-01

Figure 1 Diagram of Aircraft Mooring Anchor Area and Mooring Mode (Sheet 1 of 1)

Mooring Tool

Customers can use the part number provided by COMAC or their own equivalent equipment for mooring.

The nose landing gear mooring interface is the nose landing gear towing pin, standard AS 1614 (ISO 8267-1) category 1.

The main landing gear mooring interfaces are two lugs located on the front and rear of each main landing gear strut. The inner diameter of the front and rear mooring lug is 20 ± 0.05 mm, and the thickness is 17 ± 0.14 mm and 19 ± 0.14 mm respectively.

The length of the the mooring equipment shall meet the link requirements of the on-site mooring scheme.

The overall breaking load of the nose landing gear mooring equipment shall not be less than 8 tons, and the overall breaking load of the main landing gear mooring equipment shall not be less than 10 tons.

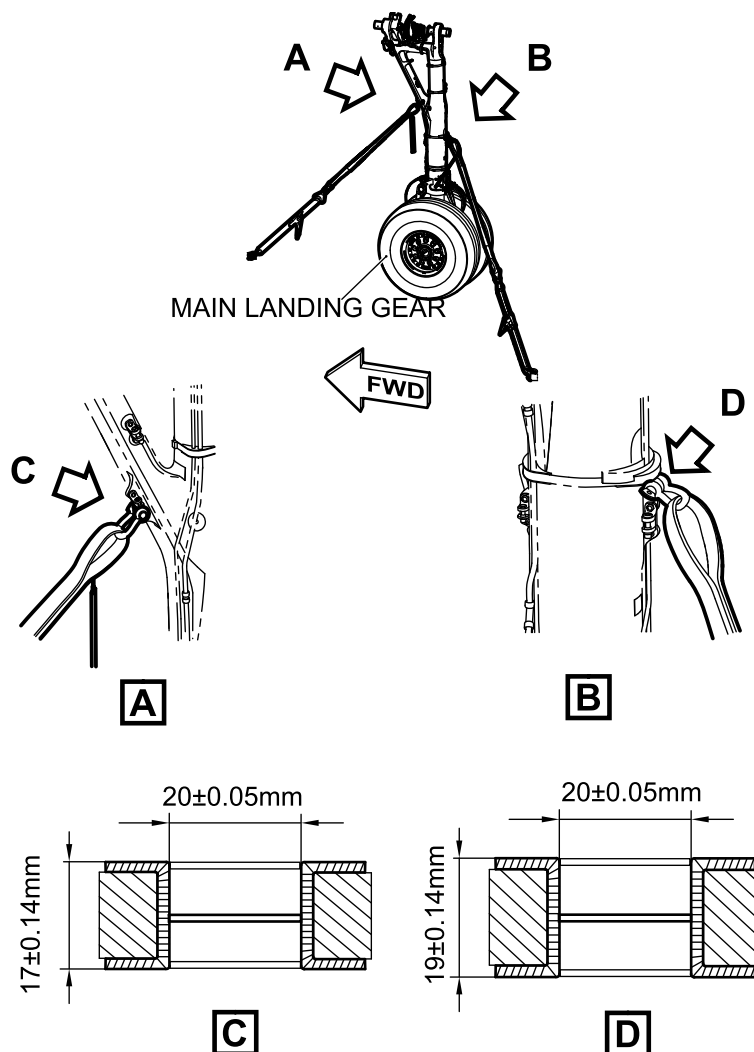

ICN-C919-A-192004-A-SVV19-77906-A-002-01

Figure 2 Lashing Strap Kit - Mooring, Main Landing Gear (Sheet 1 of 1)

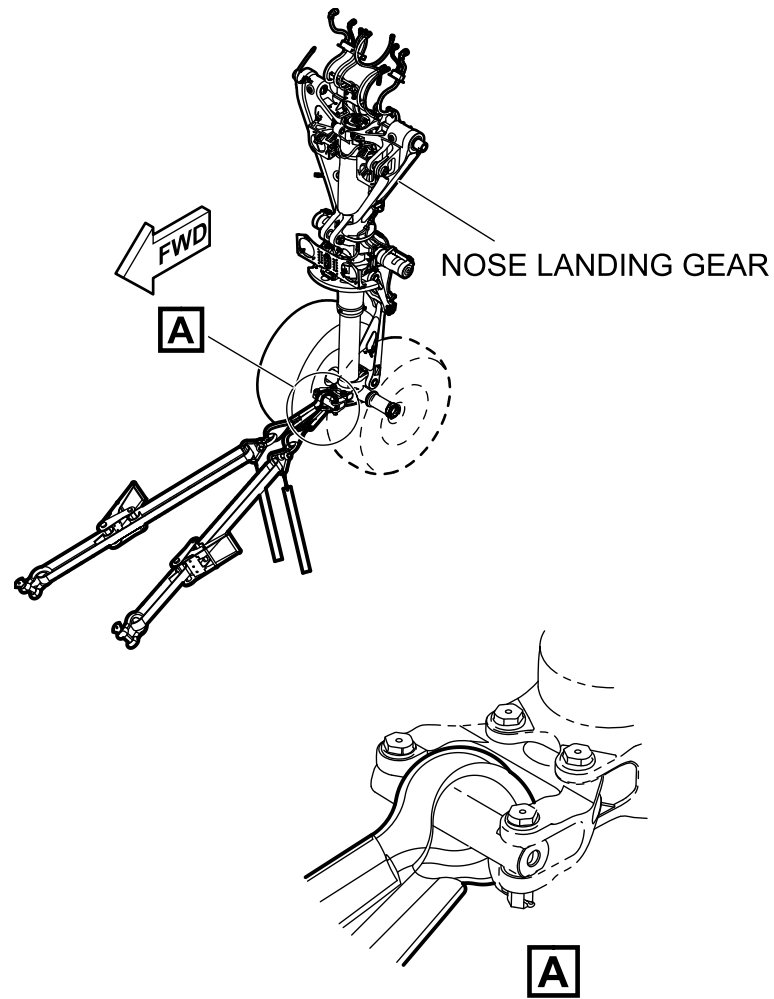

ICN-C919-A-192004-A-SVV19-77907-A-001-01

Figure 3 Lashing Strap Kit - Mooring, Nose Landing Gear (Sheet 1 of 1)

Intentionally left blank

Chapter 05

Terminal Servicing

Intentionally left blank

contents

<u>Document title</u>	<u>Data module code</u>	<u>Number of pages</u>	<u>Applicable to</u>
05 Terminal Servicing			
Aircraft Ramp Equipment Layout	C919-A-19-20-05-01A-04AA-A	1	ALL
Terminal Operations	C919-A-19-20-05-02A-04AA-A	1	ALL
Ground Service Connections	C919-A-19-20-05-03A-04AA-A	1	ALL
Engine Starting Pneumatic Requirements	C919-A-19-20-05-04A-04AA-A	1	ALL
Ground Pneumatic Requirements	C919-A-19-20-05-05A-04AA-A	1	ALL
Preconditioned Airflow Requirements	C919-A-19-20-05-06A-04AA-A	1	ALL
Hydraulic System	C919-A-19-20-05-07A-84AA-A	1	ALL
Electrical Power System	C919-A-19-20-05-08A-84AA-A	1	ALL
Oxygen System	C919-A-19-20-05-09A-84AA-A	1	ALL
Fuel System	C919-A-19-20-05-10A-84AA-A	1	ALL
Pneumatic System	C919-A-19-20-05-11A-84AA-A	1	ALL
Power Plant	C919-A-19-20-05-12A-84AA-A	1	ALL
Water/Waste System	C919-A-19-20-05-13A-84AA-A	1	ALL
Towing	C919-A-19-20-05-14A-04AA-A	1	ALL

Intentionally left blank

Aircraft Ramp Equipment Layout

Applicable to : ALL

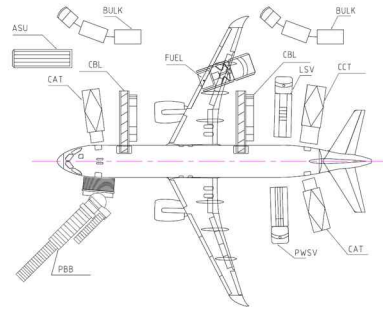

ICN-C919-A-192005-A-SVV19-10818-A-007-01

Figure 1 Aircraft Ramp Equipment Layout (Sheet 1 of 1)

Abbreviation	Definition
CAT	Catering Truck
FUEL	Aircraft Fueling Equipment
CBL	Conveyer Belt Loader
LSV	Lavatory Service Vehicle
PWSV	Potable Water Service Vehicle
ACU	Air Conditioning Unit
ASU	Air Start Unit
GPU	Gound Power Unit
PBB	Passenger Boarding Bridge
CCT	Cabin Cleaning Trcuk
BULK	Bulk Train

Intentionally left blank



Terminal Operations

1. Typical Turnaround Station (158)

Applicable to : ALL

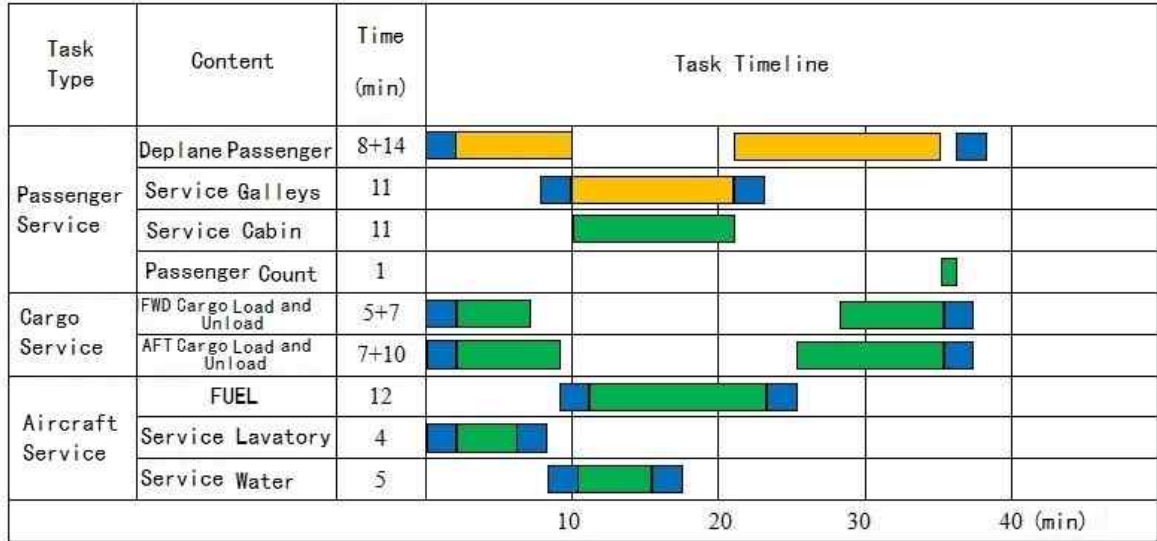

1. 158 Passengers Deplane, Unload Compartment
 - 158 New Passengers Board, Load Compartment
 2. 158 passengers board and deplane from the FWD door
 3. FUEL 9720kg (About 60% MAX FUEL)
 4. Assume One Baggage is Carried by one passenger
64 bags FWD/94 bags AFT
 5. One galley truck used
 6. Passengers Loading Rates:
Loading: 12 persons per min
Unloading: 20 persons per min
 7. Baggage Loading Rates:
Loading: 10 bags per min
Unloading: 15 bags per min
- NOTE:
- The blue line segments are for position/remove equipment
 - The green line segments are task activities
 - The orange line segments are critical path

ICN-C919-A-192005-A-SVV19-10819-A-003-01

Figure 1 Typical Turnaround Station (158) (Sheet 1 of 1)

2. Typical Turnaround Station (164)

Aircraft Characteristics for Airport Planning

Applicable to : ALL

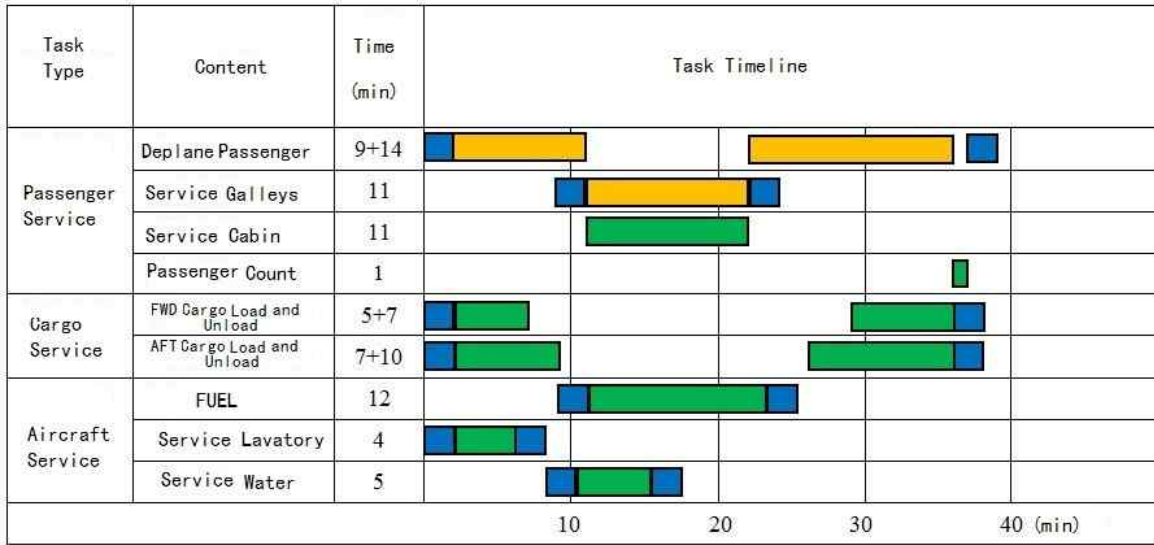

1. 164 Passengers Deplane, Unload Compartment
164 New Passengers Board, Load Compartment
 2. 164 passengers board and deplane from the FWD door
 3. FUEL 9720kg (About 60% MAX FUEL)
 4. Assume One Baggage is Carried by one passenger
66bags FWD/ 98 bags AFT
 5. One galley truck used
 6. Passengers Loading Rates:
Loading: 12 persons per min
Unloading: 20 persons per min
 7. Baggage Loading Rates:
Loading: 10 bags per min
Unloading: 15 bags per min
- NOTE: ■ The blue line segments are position/remove equipment
■ The green line segments are task activities
■ The orange line segments are critical path

ICN-C919-A-192005-A-SVV19-10820-A-004-01

Figure 2 Typical Turnaround Station (164) (Sheet 1 of 1)

3. Typical Turnaround Station (168)

Applicable to : ALL

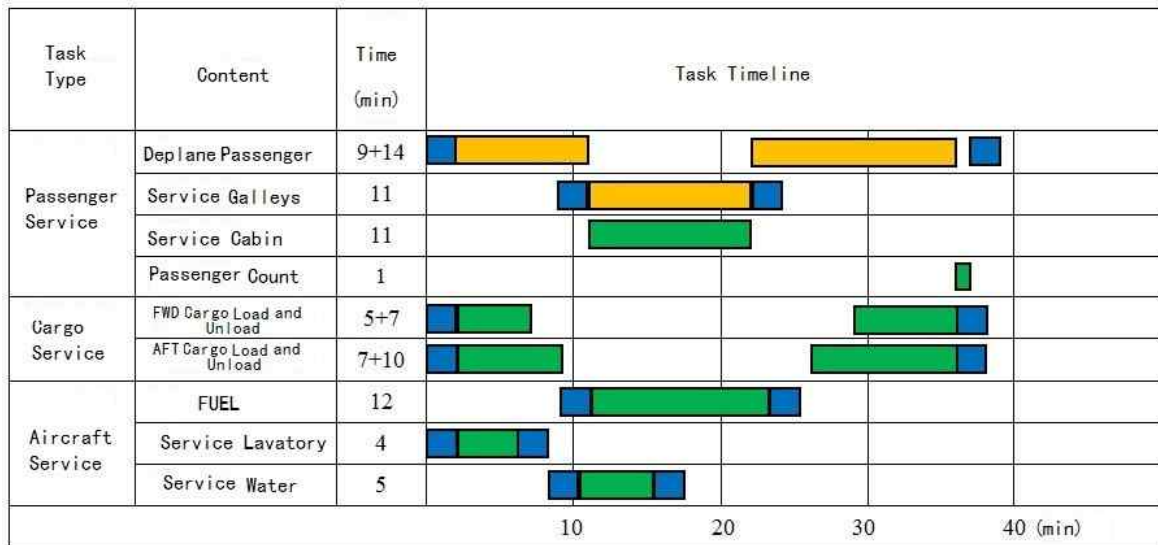

1. 168 Passengers Deplane, Unload Compartment
168 New Passengers Board, Load Compartment
 2. 168 passengers board and deplane from the FWD door
 3. FUEL 9720kg (About 60% MAX FUEL)
 4. Assume One Baggage is Carried by one passenger
68 bags FWD/100 bags AFT
 5. One galley truck used
 6. Passengers Loading Rates:
Loading: 12 persons per min
Unloading: 20 persons per min
 7. Baggage Loading Rates:
Loading: 10 bags per min
Unloading: 15 bags per min
- NOTE: ■ The blue line segments are for position/remove equipment.
■ The green line segments are task activities
■ The orange line segments are critical path

ICN-C919-A-192005-A-SVV19-77931-A-001-01

Figure 3 Typical Turnaround Station3 (Sheet 1 of 1)

4. Typical Turnaround Station (174)

Aircraft Characteristics for Airport Planning

Applicable to : ALL

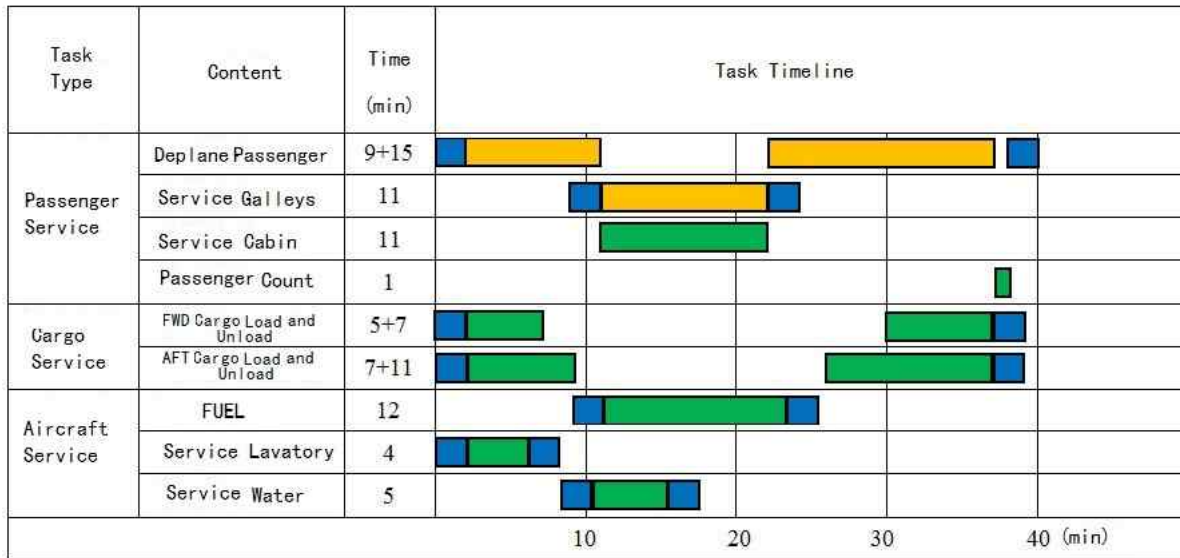

1. 174 Passengers Deplane, Unload Compartment
174 New Passengers Board, Load Compartment
 2. 174 passengers board and deplane from the FWD door
 3. FUEL 9720kg (About 60% MAX FUEL)
 4. Assume One Baggage is Carried by one passenger
70 bags FWD/104 bags AFT
 5. One galley truck used
 6. Passengers Loading Rates:
Loading: 12 persons per min
Unloading: 20 persons per min
 7. Baggage Loading Rates:
Loading: 10 bags per min
Unloading: 15 bags per min
- NOTE: ■ The blue line segments are for position/remove equipment
 ■ The green line segments are task activities
 ■ The orange line segments are critical path

ICN-C919-A-192005-A-SVV19-77932-A-001-01

Figure 4 Typical Turnaround Station (174) (Sheet 1 of 1)

5. Quick Turnaround Station

Applicable to : ALL

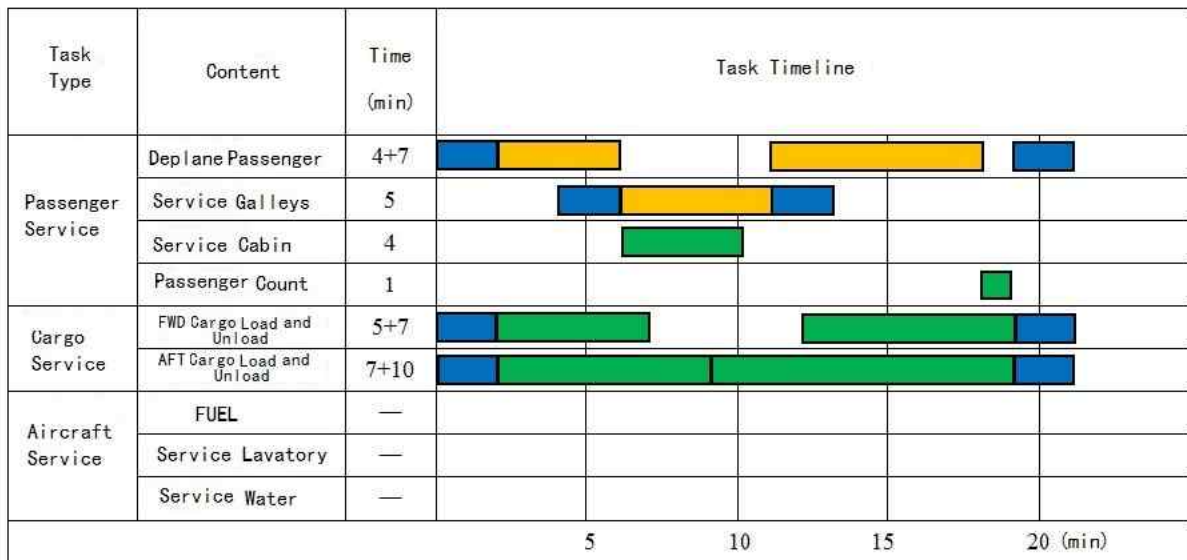

1. 158 Passengers Deplane, Unload Compartment
158 New Passengers Board, Load Compartment
 2. 79 passengers board and deplane from the left FWD passenger entry door
79 passengers board and deplane from the left AFT passenger entry door
 3. FUEL 9720kg (About 60% MAX FUEL)
 4. Assume One Baggage is Carried by one passenger
64 bags FWD/94 bags AFT
 5. One galley truck used
 6. Passengers Loading Rates:
Loading: 12 persons per min
Unloading: 20 persons per min
 7. Baggage Loading Rates:
Loading: 10 bags per min
Unloading: 15 bags per min
- NOTE: ■ The blue line segments are for position/remove equipment
■ The green line segments are task activities
■ The orange line segments are critical path

ICN-C919-A-192005-A-SVV19-10821-A-003-01

Figure 5 Quick Turnaround Station (Sheet 1 of 1)

Intentionally left blank

Ground Service Connections

Applicable to : ALL

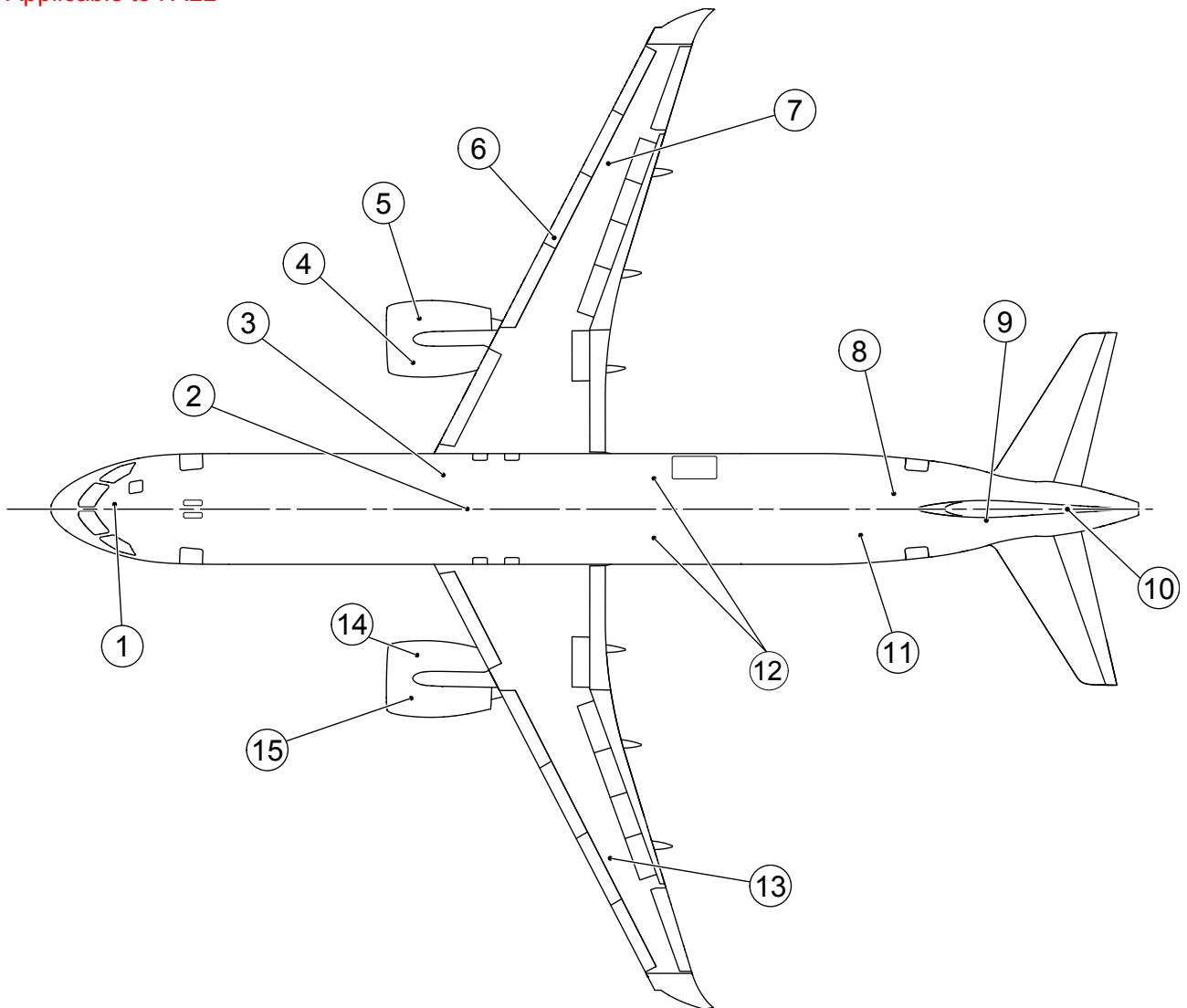

ICN-C919-A-192005-A-SVV19-10807-A-004-01

Figure 1 Ground Service Connections (Sheet 1 of 1)

Table 1 Service Provider

No.	Service Provider
1	Ground Electrical Power Service Connection
2	High Pressure Ground Air Source Service Connection
3	Low Pressure Ground Air Source Service Connection
4	Variable Frequency Generator Oil Filling Port
5	Engine Oil/Artificial Gravity Filling Port
6	Refuel/Defuel Connection

**Aircraft Characteristics for Airport
Planning**

No.	Service Provider
7	Gravity Fill Connection
8	Waste Service Panel
9	Hydraulic Service Connection
10	APU Oil Connection
11	Water Service Connection
12	Hydraulic Service Connection
13	Gravity Fill Connection
14	Engine Oil/Artificial Gravity Filling Port
15	Variable Frequency Generator Oil Filling Port

Engine Starting Pneumatic Requirements

The function of this section gives the minimum air data requirements at the aircraft connection, needed to start the engine within no more than 150 seconds, at sea level (0 feet), for a set of Outside Air Temperatures (OAT).

Abbreviation	Definition
ASU	Air Start Unit
HPGC	High Pressure Ground Connection
OAT	Outside Air Temperature

- (1) This section addresses requirements for the ASU only, and is not representative of the start performance of the aircraft using the APU or engine cross bleed procedure.
- (2) The temperature must be less than 220 °C (428 °F).
- (3) The recommended pressure at HPGC is 40 psig (55 psia).
- (4) The OAT and the ASU performance (see the technical data from the ASU manufacturer) effect the ASU output temperature.

Applicable to : ALL

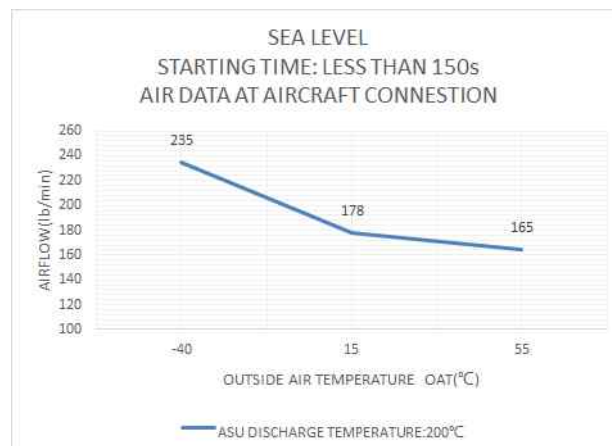

ICN-C919-A-192005-A-SVV19-68873-A-001-01

Figure 1 (Sheet 1 of 1)

EXAMPLE:

'15,178' in the chart means that when ASU discharge temperature is 200 °C, and the OAT is 15 °C, the minimum air data requirements at the aircraft connection is 178 lb/min.

Intentionally left blank



Ground Pneumatic Requirements

Applicable to : ALL

HEATING

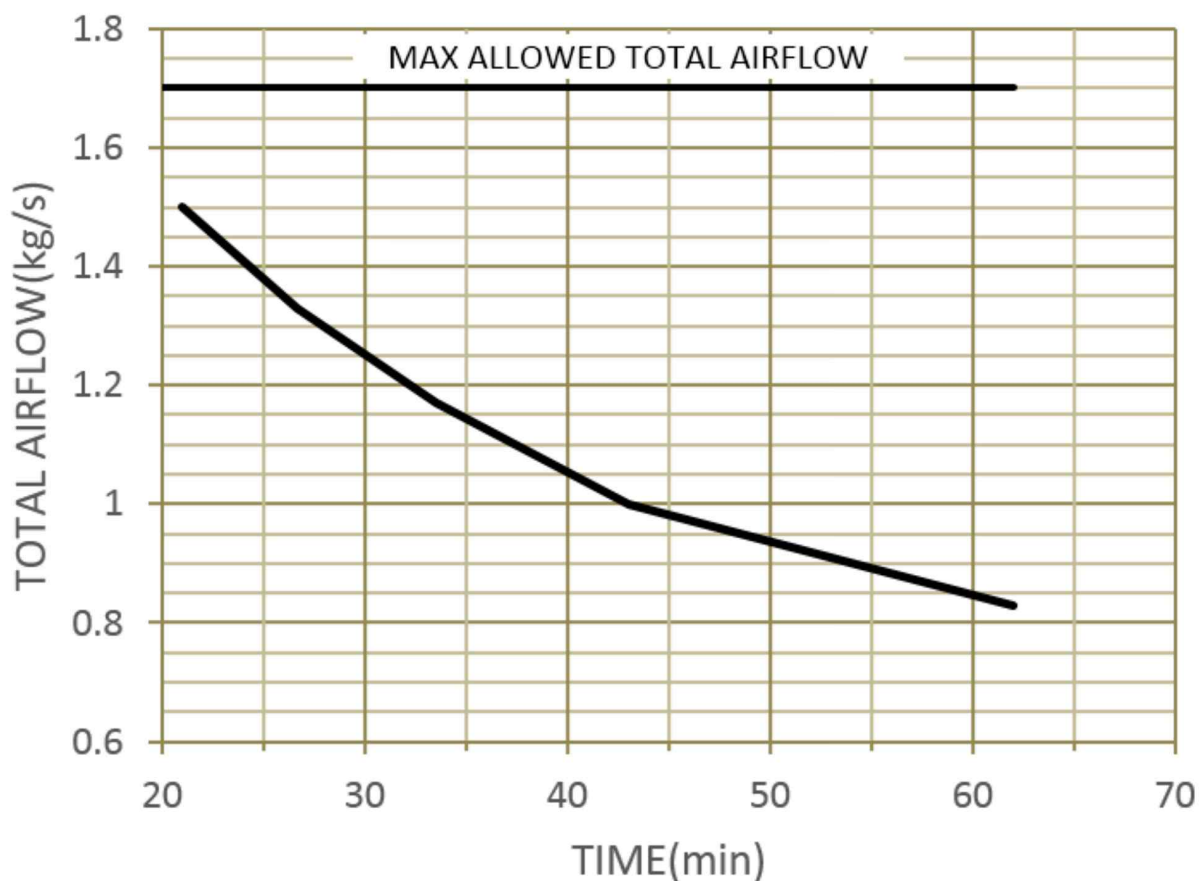

ICN-C919-A-192005-A-SVV19-22956-A-001-01

Figure 1 Heating (Sheet 1 of 1)

Initial cabin temperature is **-30°C** , target cabin temperature is **21°C** , the temperature of air supplied from low pressure ground connection is **70°C** .

Aircraft condition:

- standard sea level
- no passengers
- recirculation fans on
- doors and windows are closed
- no other heat load and electricity load.

Applicable to : ALL

COOLING

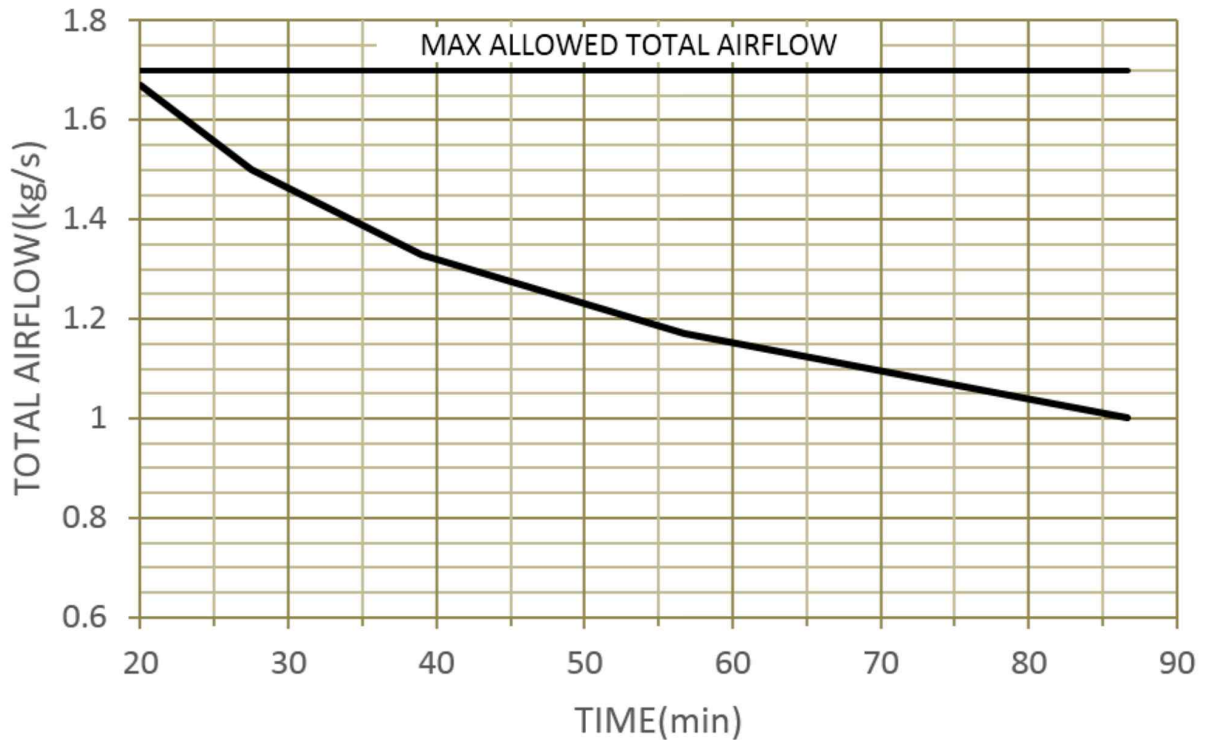

ICN-C919-A-192005-A-SVV19-22959-A-001-01

Figure 2 Cooling (Sheet 1 of 1)

Initial cabin temperature is **40°C** , target cabin temperature is **27°C** , the temperature of air supplied from low pressure ground connection is **1.5°C** .

Aircraft condition:

- standard sea level
- no passengers
- recirculation fans on
- doors and windows are closed
- sun radiation is **1400 W**
- electricity load is **1040 W** .

Intentionally left blank

Preconditioned Airflow Requirements

Applicable to : ALL

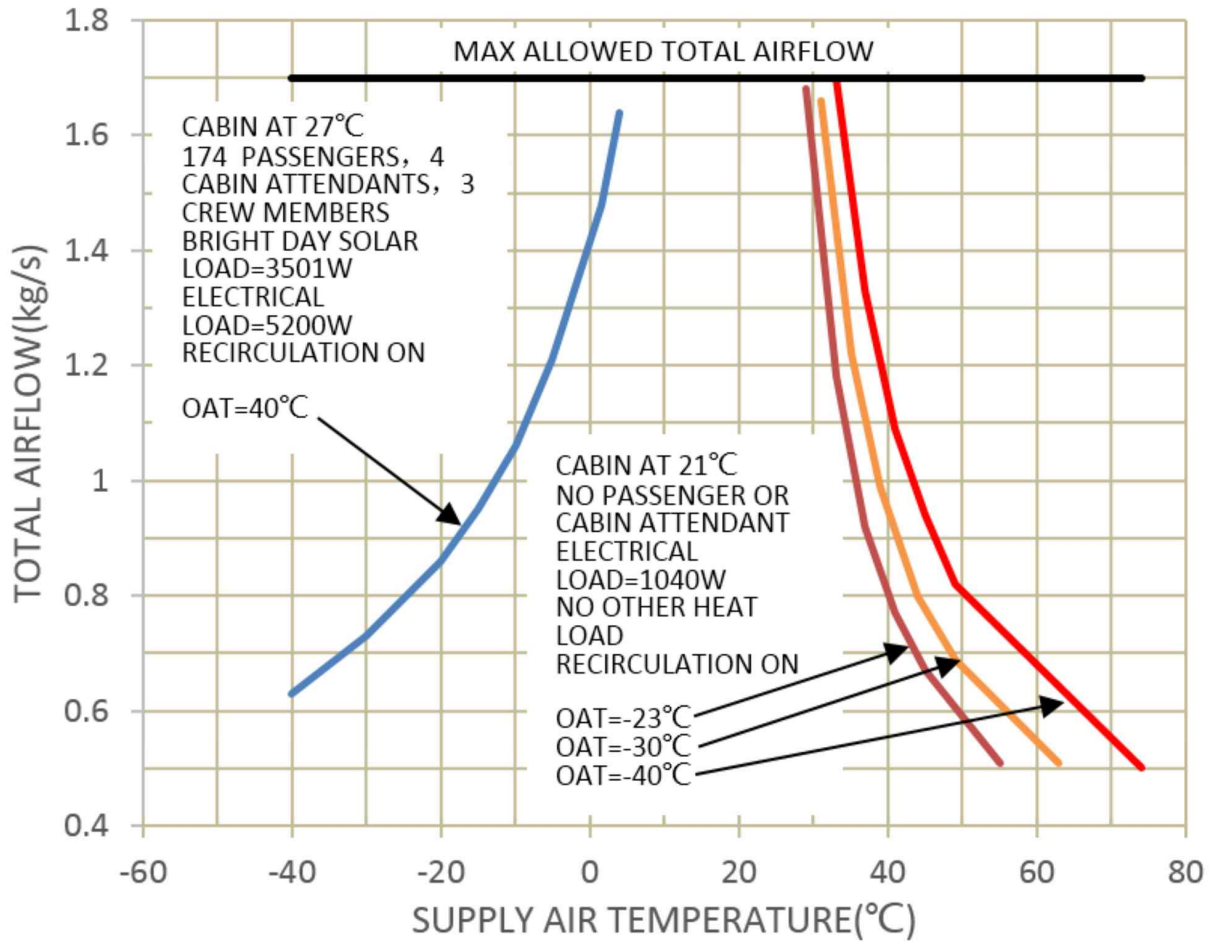

ICN-C919-A-192005-A-SVV19-22962-A-001-01

Figure 1 Preconditioned Airflow Requirement (Sheet 1 of 1)

Intentionally left blank

Hydraulic System

Description

Preconditions are ambient temperature 15°C, standard atmospheric pressure, and use of OEW weight.

Access Panels

Access Panel	Access Panel Number	Distance from the nose (Units : m)	Distance to plane of symmetry (Units : m)		Altitude above ground (Units : m)	
			Left	Right	Center of gravity front limit	Center of gravity rear limit
No.1 system Ground maintenance panel	197EB	21.09	0.67	/	1.87	1.82
No.2 System Ground maintenance panel	198NR	20.82	/	0.90	1.84	1.80
Aft fuselage fwd maintenance panel	311AB	33.33	0.38	/	3.34	3.17

Fitting

Fitting	Fitting size (r is the fitting radius, Units:mm)
Hydraulic-reservoir pressurization fitting	r=25.53
Accumulator charging fitting	44.45*44.45
Hydraulic-reservoir refueling fitting	r=22.99
Hydraulic-reservoir return fitting	r=31.75

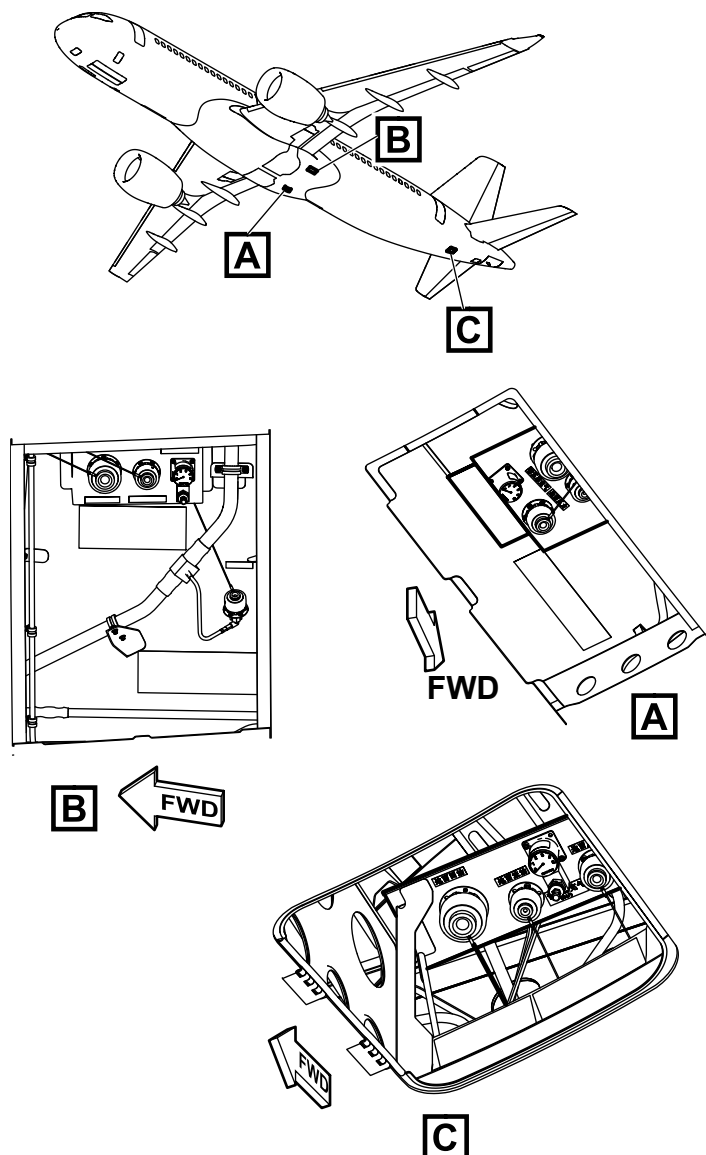

ICN-C919-A-192005-A-SVV19-65122-A-002-01

Figure 1 Hydraulic access panel and fitting (Sheet 1 of 1)



Electrical Power System

Description

Preconditions are ambient temperature 15°C, standard atmospheric pressure, and use of OEW weight.

Access Panels

Access Panel	Access Panel Number	Distance from the nose(Units:m)	Forward of the centerline of the fuselage Size(left side) (Units:m)	Forward of the centerline of the fuselage Size(right side) (Units:m)	Altitude above ground (Units:m)	
					Forward limit of center of gravity (12%MAC)	Back limit of center of gravity (35.14%MAC)
Ground power maintenance panel	122AR	2.2	/	0.21	1.97	2.12

A. The socket complies with ISO 461 standard, with a rated input power of 90 kVA.

B. 115/200V, 400Hz three-phase AC power.

C. When supplying to the aircraft from an external power source, the output cable must be connected to an aircraft external power socket that meets the standard ISO 461.

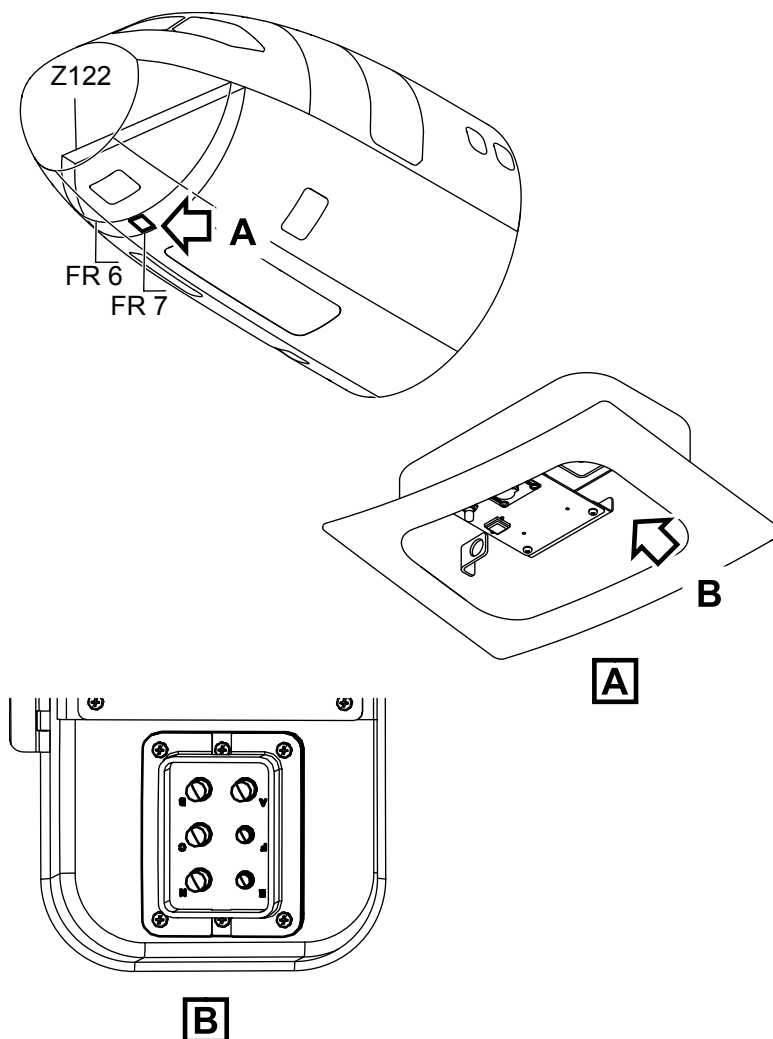

ICN-C919-A-192005-A-SVV19-65125-A-001-01

Figure 1 Ground power socket (Sheet 1 of 1)



Oxygen System

Description

Preconditions are ambient temperature 15°C, standard atmospheric pressure, and use of OEW weight.

Access Panels

Access Panel	Access Panel Number	Distance from the nose(Units:m)	Forward of the centerline of the fuselage Size(left side) (Units:m)	Forward of the centerline of the fuselage Size(right side) (Units:m)	Altitude above ground (Units:m)	
					Center of gravity front limit	Center of gravity rear limits
Oxygen filling service panel	131AL	8.77	1.79	/	3.01	3.09

Table 1 Fitting

Fitting	Size (Units : in)
Oxygen filling valve	0.25

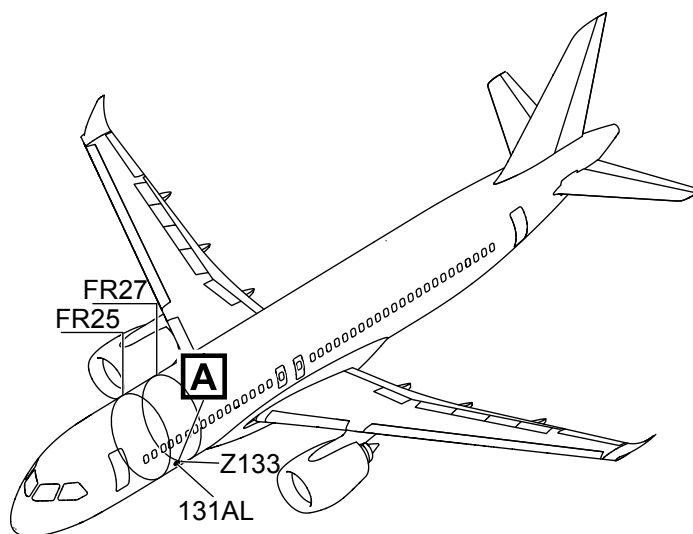

OXYGEN FILLING
SERVICE PANEL

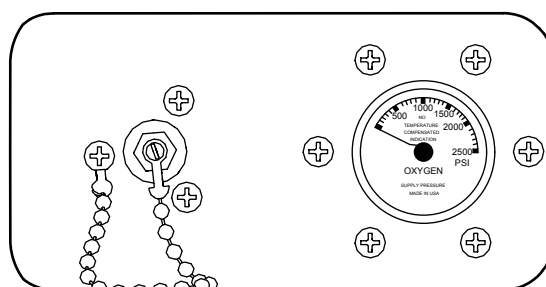

A



ICN-C919-A-192005-A-SVV19-65123-A-001-01

Figure 1 Oxygen Filling Service Panel (Sheet 1 of 1)



Fuel System

Description

Preconditions are ambient temperature 15°C, standard atmospheric pressure, and use of OEW weight.

Access Panels

Access Panel	Access Panel Number	Distance from the nose(Units:m)	Forward of the centerline of the fuselage Size(left side) (Units:m)	Forward of the centerline of the fuselage Size(right side) (Units:m)	Altitude above ground, 12%MAC(Units:m)	Altitude above ground, 35.14%MAC(Units:m)
Pressure refuel door	620VB	18.27	/	10.08	3.76	3.75
Gravity refuel cap (right)	Null	19.78	/	12.34	4.26	4.23
Gravity refuel cap (left)	Null	19.78	12.34	/	4.26	4.23

Fitting

Fitting	Size (Units:in)	Standrd
Pressure fuel fitting	2.5	/

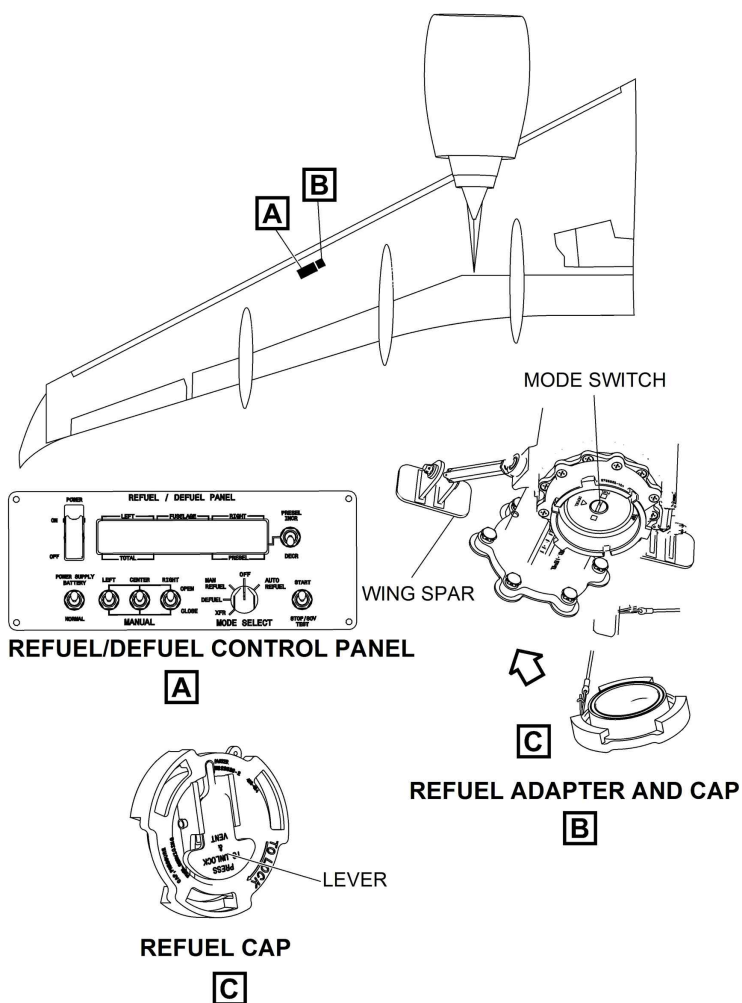

ICN-C919-A-192005-A-SVV19-66037-A-002-01

Figure 1 Pressure refueling with automatic control (Sheet 1 of 1)

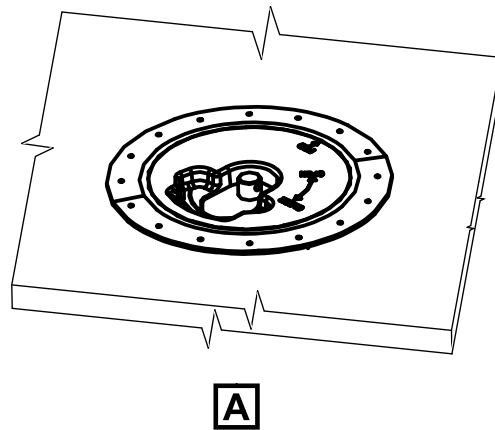
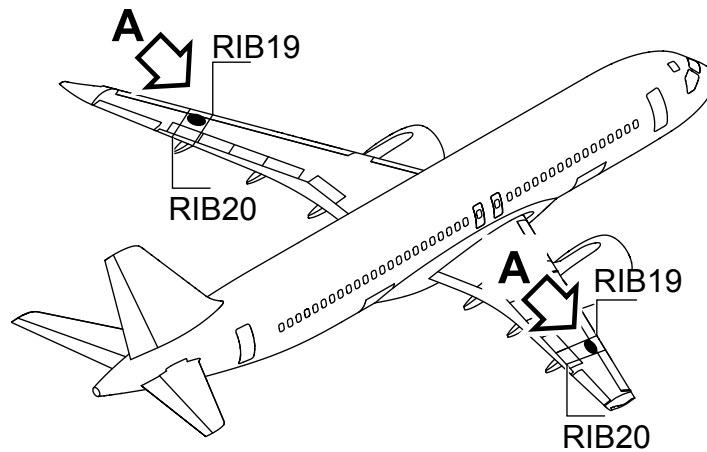

ICN-C919-A-121128-A-SVV19-20494-A-001-01

Figure 2 Gravity Refueling Port Location (Sheet 1 of 1)

Intentionally left blank



Pneumatic System

Description

Preconditions are ambient temperature 15°C, standard atmospheric pressure, and use of OEW weight.

Access Panels

Access Panel	Access Panel Number	Distance from the nose(Units:m)	Forward of the centerline of the fuselage Size(left side) (Units:m)	Forward of the centerline of the fuselage Size(right side) (Units:m)	Altitude above ground (Units:m)	
					Forward limit of center of gravity (12%MAC)	Back limit of center of gravity (35.14%MAC)
High pressure pneumatic maintenance door assembly	195BB	14.95	/	/	1.54	1.56
Low pressure pneumatic maintenance door assembly	192DR	13.98	/	1.28	1.72	1.75

Fitting

Fitting	Size (in)	Standrd
High Pressure Ground Connector	3	ISO2026
Low Pressure Ground Connector	8	MS33562

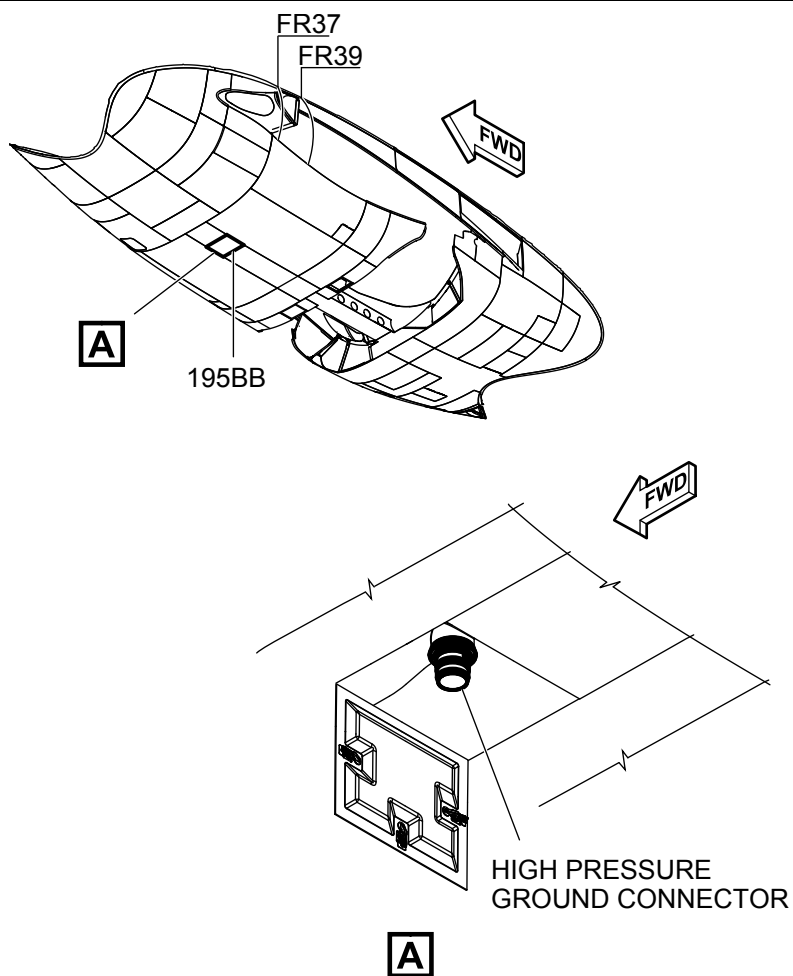

ICN-C919-A-192005-A-SVV19-65124-A-002-01

Figure 1 High Pressure Ground Connector (Sheet 1 of 1)

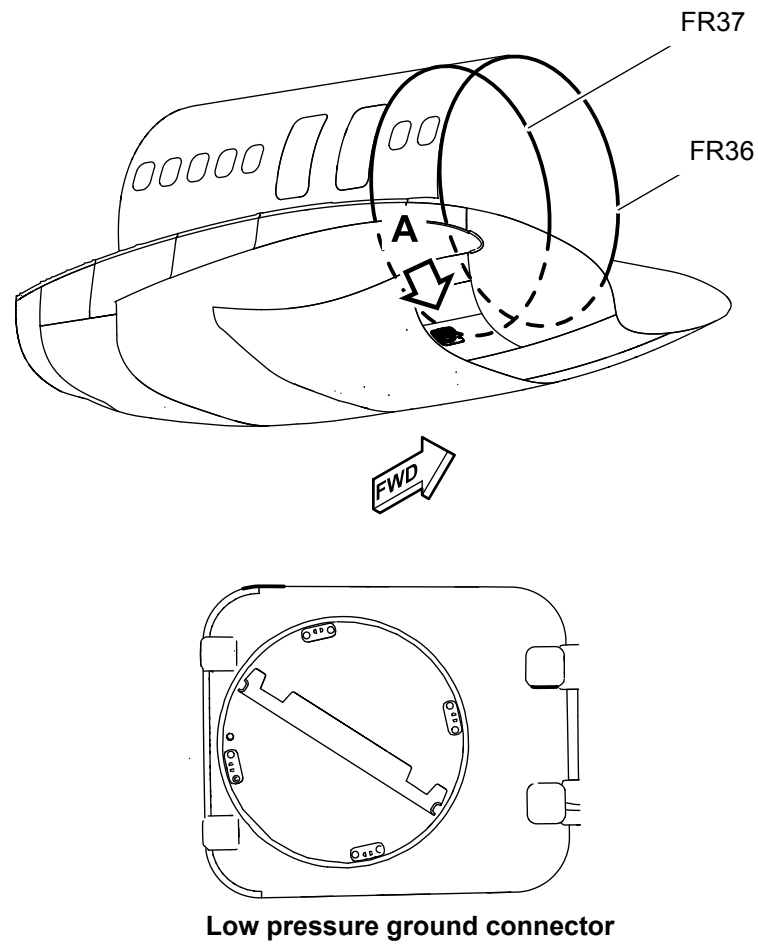

A

ICN-C919-A-192005-A-SVV19-66043-A-001-01

Figure 2 Low Pressure Ground Connector (Sheet 1 of 1)

Intentionally left blank



Power Plant

Description

Preconditions are ambient temperature 15°C, standard atmospheric pressure, and use of OEW weight.

Access Panels

Access Panel	Access Panel Number	Distance from the nose(Units: mm)	Distance to plane of symmetry (Units : m)		Altitude above ground (Units : m)	
			Left	Right	Center of gravity front limit(12%MAC)	Center of gravity rear limit(35.14%MAC)
Oil Tank Access Panel(LEFT)	414AR	13.72	4.72	/	1.79	1.82
Oil Tank Access Panel(RIGHT)	424AR	13.72	/	4.72	1.79	1.82

Fitting

Fitting	Part Number	Fitting size (r is the fitting radius, Units:mm)
VFG Oil Pressure Fuel Fitting	2421C00102G99 (AS5205-06)	r=16.43
Engine Oil Pressure Fuel Fitting	SN_L-362-094-111-0_P_00_002	r=28.70

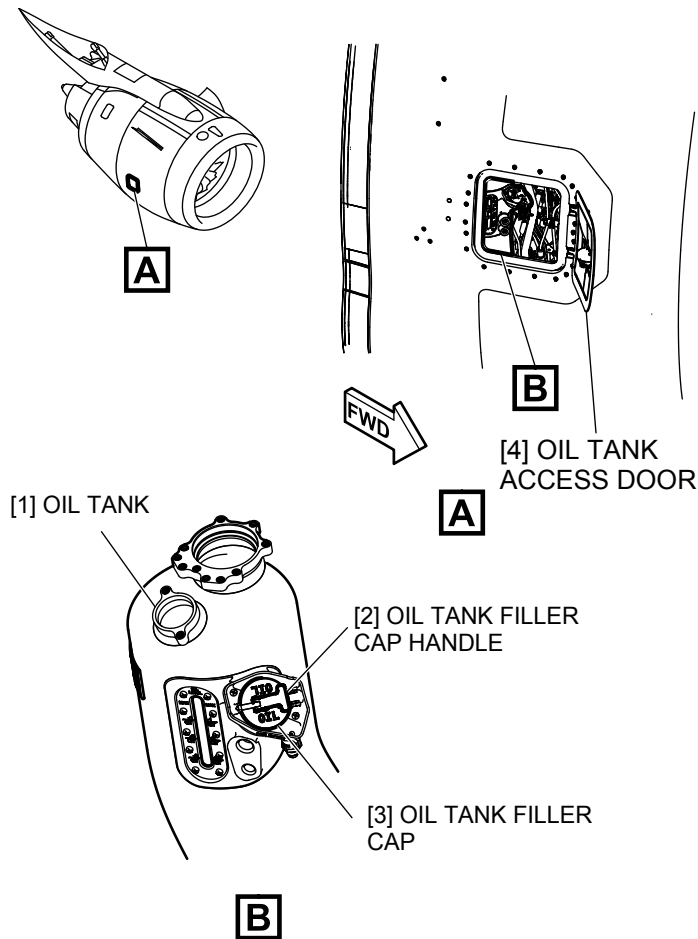

ICN-C919-A-192005-A-SVV19-66044-A-001-01

Figure 1 Engine oil Service (Sheet 1 of 1)



Water/Waste System

Description

Preconditions are ambient temperature 15°C, standard atmospheric pressure, and use of OEW weight.

The maximum usable capacity of a water tank in the potable water system is 171 L.

The maximum usable capacity of a water tank in the waste system is 227 L.

Water tank filling pressure reference standard MHT_6014-1999 is 0.25-0.35 MPa.

The flushing pressure of waste water tank refers to standard MHT_6015-1999 is 0.25-0.35 MPa.

Water Service Access Panels

Access Panel	Access Panel Number	Distance from the nose(Units:m)	Forward of the centerline of the fuselage Size(left side) (Units:m)	Forward of the centerline of the fuselage Size(right side) (Units:m)	Altitude above ground (Units:m)	
					Center of gravity front limit	Center of gravity rear limits
Water Service Panel Door	173AL	28.51	0.87	/	2.45	2.34

Table 1 Waste Service Access Panels

Access Panel	Access Panel Number	Distance from the nose(Units:m)	Forward of the centerline of the fuselage Size(left side) (Units:m)	Forward of the centerline of the fuselage Size(right side) (Units:m)	Altitude above ground (Units:m)	
					Center of gravity front limit	Center of gravity rear limits
Waste Service Panel Door	198NR	30.17	/	0.52	2.63	2.50

Water Service Fitting

Fitting	Size (Units:in)	Standrd
Water Fill Port	0.75	ISO 17775

**Aircraft Characteristics for Airport
Planning**

Table 2 Waste Service Fitting

Fitting	Size (Units:in)	Standrd
Waste Rinse Fitting	1	ISO 17775
Waste Drain Fitting	4	ISO 17775

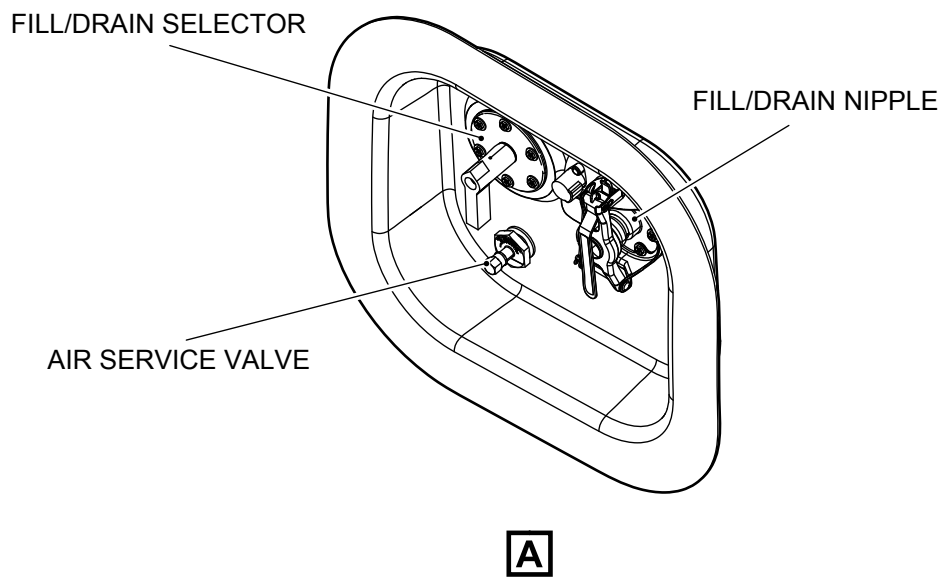
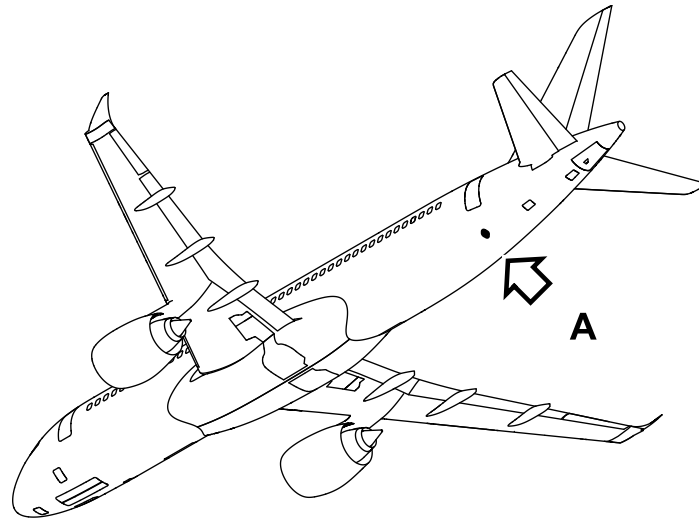

ICN-C919-A-381000-A-SVV19-18116-A-001-01

Figure 1 Portable water servicing (Sheet 1 of 1)

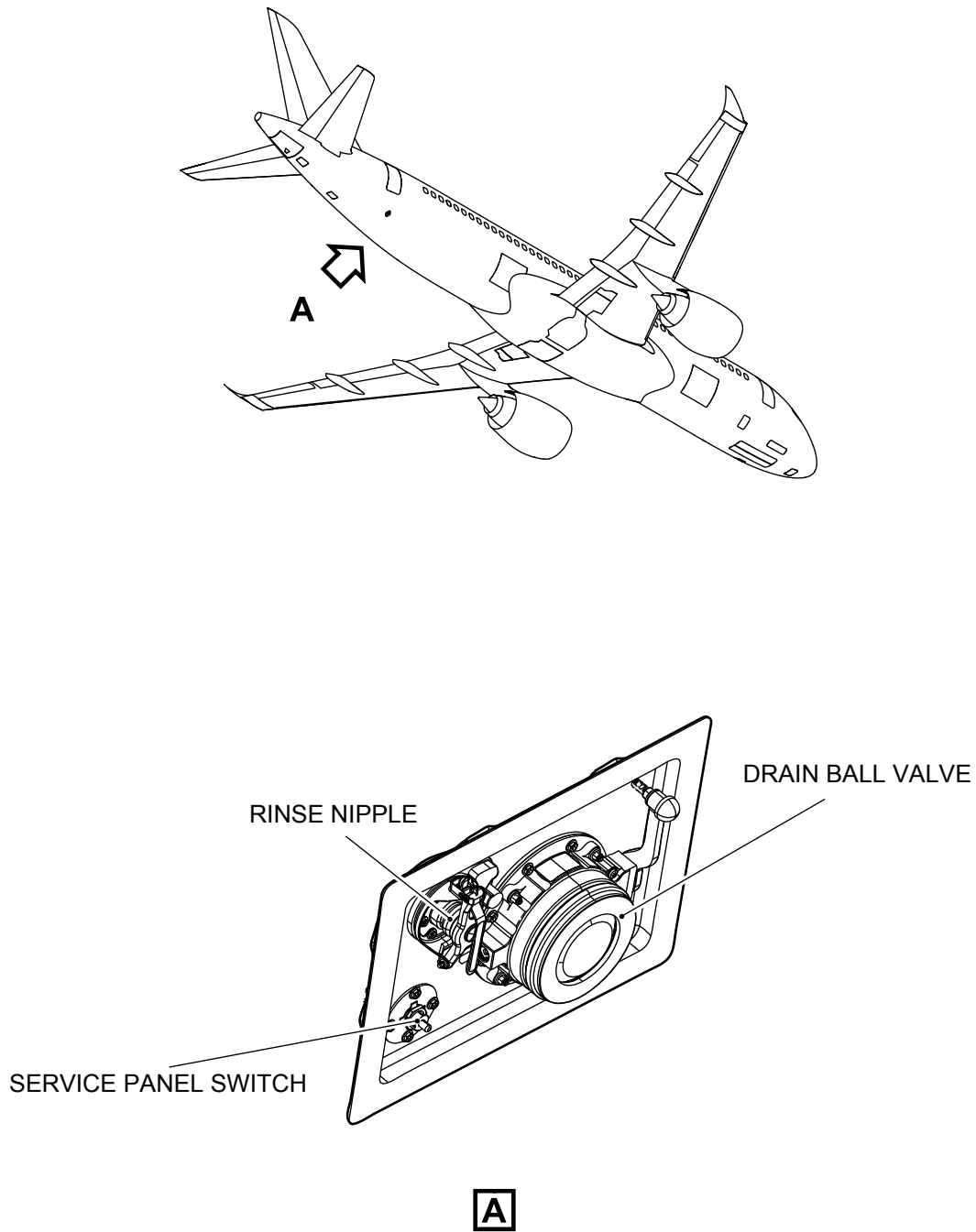

ICN-C919-A-383000-A-SVV19-18119-A-001-01

Figure 2 Waste water servicing (Sheet 1 of 1)

Towing

1. Description

You can tow the aircraft by the nose landing gear or the main landing gear. The towing of aircraft can be divided into normal towing and emergency towing.

2. Limitations

The maximum draught weight of the aircraft is 79300 kg.

The maximum towing angle of the nose wheel is 95° relative to the neutral position with a towbar.

When you tow the airplane with a towbar, the speed for forward towing in a straight line shall not exceed 25 km/h .

The speed for backward towing in a straight line shall not exceed 5 km/h.

The towing speed for turning shall not exceed 5 km/h. (includes turning when forward towing and pushing backward.)

3. Tow tractor weight calculation curve

Applicable to : ALL

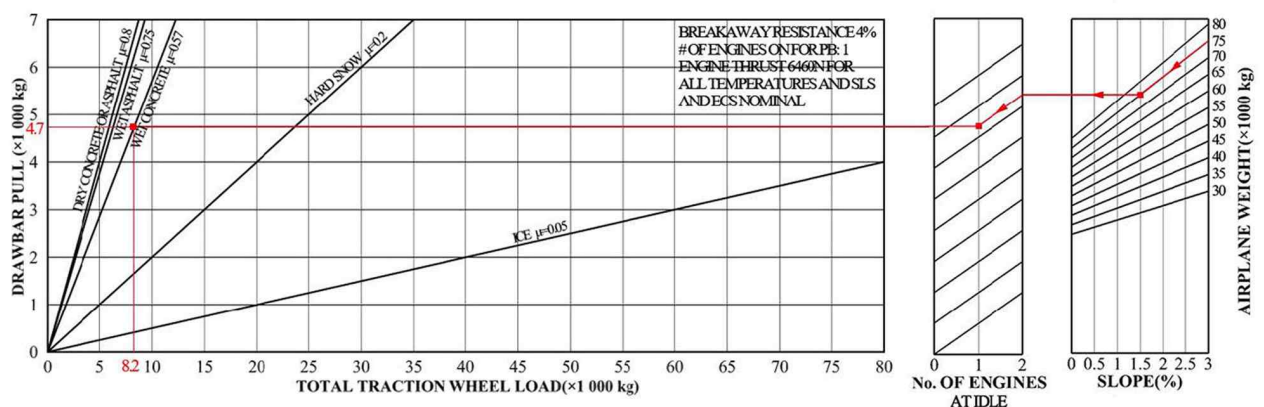

ICN-C919-A-192005-A-SVV19-71295-A-001-01

Figure 1 AIRPLANE WEIGHT (x1000 kg) (Sheet 1 of 1)

EXAMPLE HOW TO DETERMINE THE MASS REQUIREMENT TO TOW AT 75000 kg, AT 1.5% SLOPE. ONE ENGINE AT IDLE AND FOR WET TARMAC CONDITIONS:

ON THE RIGHT HAND SIDE OF THE GRAPH, CHOOSE THE RELEVANT AIRCRAFT WEIGHT (75000 kg).

FROM THIS POINT DRAW A PARALLEL LINE TO THE REQUIRED SLOPE PERCENTAGE (1.5%).

FROM THE POINT OBTAINED DRAW A STRAIGHT HORIZONTAL LINE UNTIL No. OF ENGINES AT IDLE = 2.

FROM THIS POINT DRAW A PARALLEL LINE TO THE REQUESTED No. OF ENGINES (1).

Aircraft Characteristics for Airport Planning

FROM THIS POINT DRAW A STRAIGHT HORIZONTAL LINE TO THE DRAWBAR PULL AXIS. THE Y-COORDINATE OBTAINED IS THE NECESSARY DRAWBAR PULL FOR THE TRACTOR (4700 kg).

SEARCH THE INTERSECTION WITH THE "WET CONCRETE" LINE. THE OBTAINED X-COORDINATE IS THE TOTAL TRACTION WHEEL LOAD (8200 kg).

NOTE: The three parts of the figure share the coordinate DRAWBAR PULL (Towing Load).

The figure does not take into account the influence of wind speed. In order to ensure the safety of the towing process, tow tractor with greater weight should be appropriately selected in windy weather.

4. Towbar design guidelines

- (1) The aircraft towbar shall comply with the following standards,
 - ISO 8267-1 "Aircraft - Towbar Attachment Fitting - Interface Requirements - Part 1: Main Line Aircraft"
 - SAE AS 1614 "Main Line Aircraft Towbar Attach Fitting Interface"
 - ISO 9667 "Aircraft Ground Support Equipment - Towbar"
 - SAE ARP 1915 "Aircraft Towbar"
 - IATA Airport Handling Manual AHM 958 "Functional Specification for an Aircraft Towbar"
- (2) The aircraft towbar should have a buffer device to prevent the nose landing gear from being impacted, and a limited load and torque protection device (usually safety pins or safety bolts).
When towing:
 - The limited load of nose landing gear is 116,650 N.
 - The limited Torque of nose landing gear is 8,733 N·m.
- (3) The towing head is designed according to SAE AS 1614(ISO 8267-1), Category.I.

Chapter 06

Operating Conditions

Intentionally left blank

contents

<u>Document title</u>	<u>Data module code</u>	<u>Number of pages</u>	<u>Applicable to</u>
06 Operating Conditions			
Jet Engine Exhaust Temperatures	C919-A-19-20-06-01A-04AA-A	1	ALL
Airport and Community Noise	C919-A-19-20-06-02A-04AA-A	1	ALL
Jet Engine Exhaust Velocities and Danger Areas	C919-A-19-20-06-03A-04AA-A	1	ALL
APU Exhaust Velocities and Temperatures	C919-A-19-20-06-04A-04AA-A	1	ALL

Intentionally left blank

Jet Engine Exhaust Temperatures

Aircraft Characteristics for Airport Planning

Applicable to : ALL

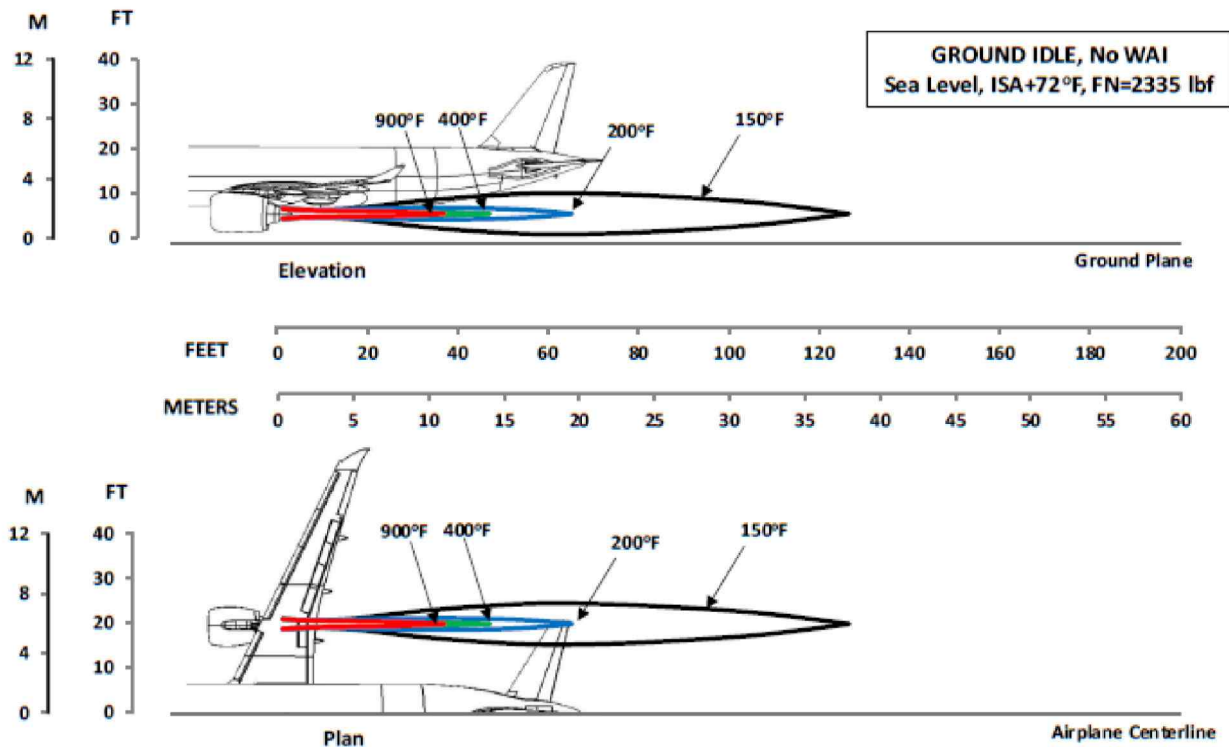

ICN-C919-A-192006-A-SVV19-10841-A-002-01

Figure 1 Engine Exhaust Temperatures – Ground Idle Thrust (Sheet 1 of 1)

Applicable to : ALL

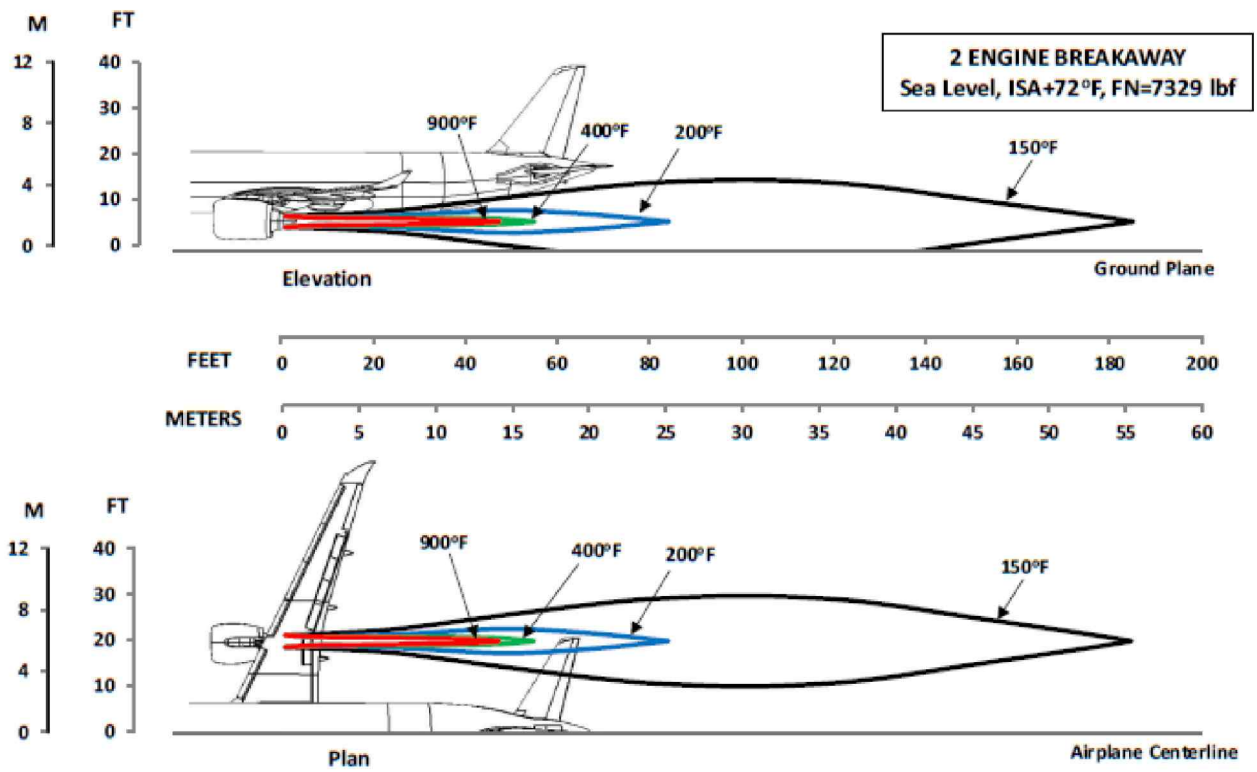

ICN-C919-A-192006-A-SVV19-10844-A-002-01

Figure 2 Engine Exhaust Temperatures – Two Engine Breakaway Thrust (Sheet 1 of 1)

Applicable to : ALL

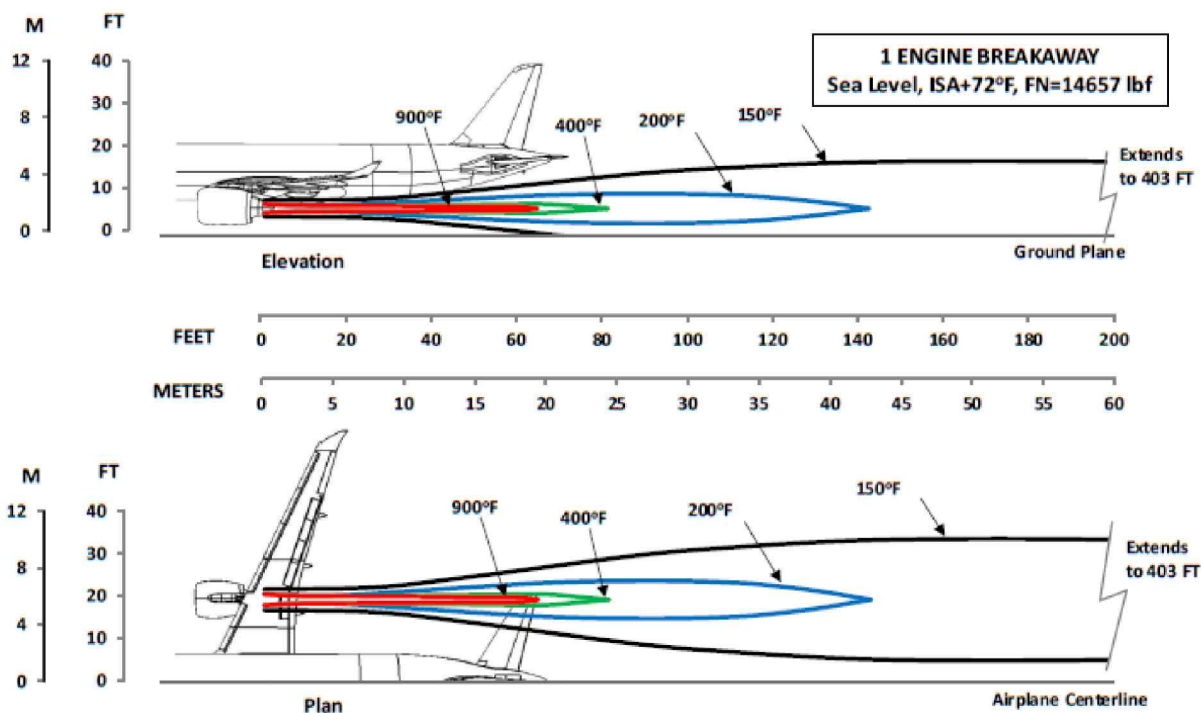

ICN-C919-A-192006-A-SVV19-10843-A-002-01

Figure 3 Engine Exhaust Temperatures – One Engine Breakaway Thrust (Sheet 1 of 1)

Applicable to : ALL

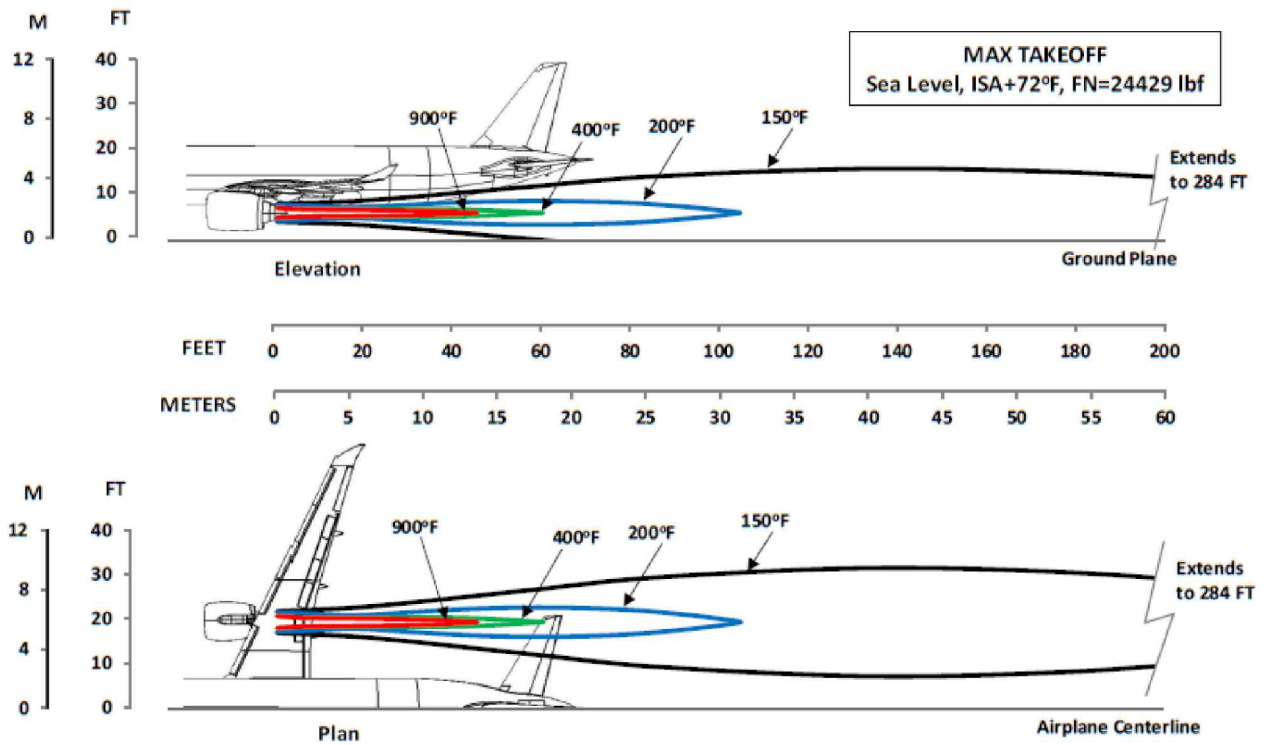

ICN-C919-A-192006-A-SVV19-10842-A-002-01

Figure 4 Engine Exhaust Temperatures – Max Takeoff Thrust (Sheet 1 of 1)



Intentionally left blank

Airport and Community Noise

The following picture provides only the description of acoustic area. Picture is not to scale.

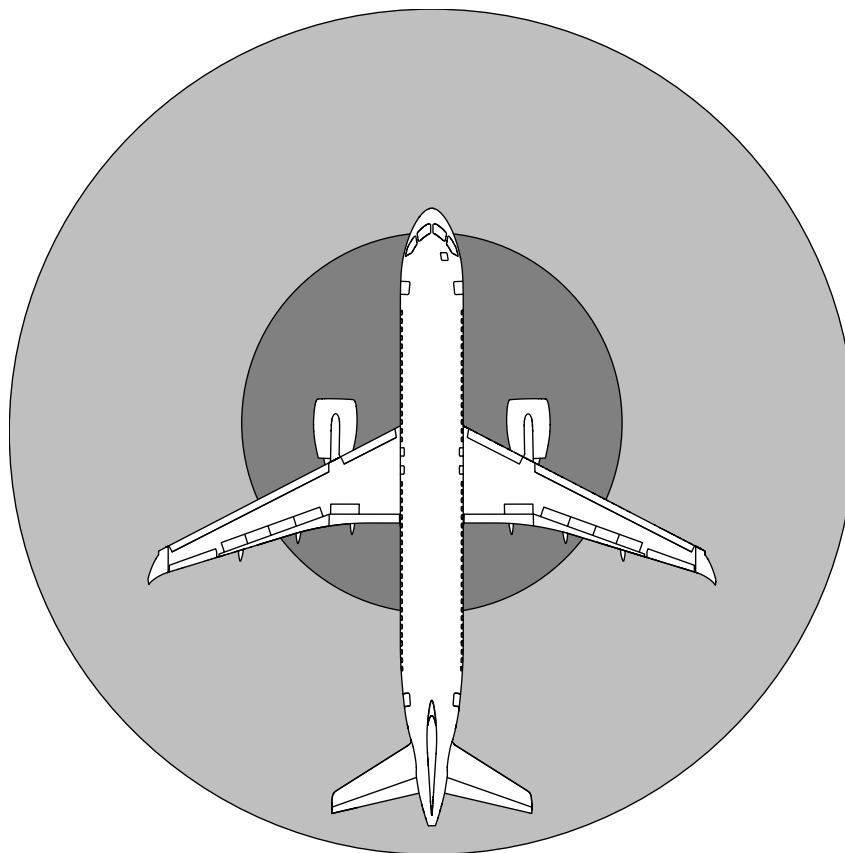
Applicable to : ALL



-  Ear protection is required within this area.
 Forbidden area.

ICN-C919-A-192006-A-SVV19-10815-A-001-01

Figure 1 Engine Acoustic Hazard Area (Sheet 1 of 1)

Note: Based on 2 engines acoustic evaluation with production nacelle at ISA+15, sea level static and 70% of humidity conditions. Specification for ear protection devices should meet or exceed the values of noise reduction as tabulated in the following table.

Frequency [Hz]	63	125	250	500	1000	2000	4000	8000
Attenuation [dB(A)]	0.8	2.8	7.2	10.4	14.8	17.2	24.0	23.7

Applicable to : ALL

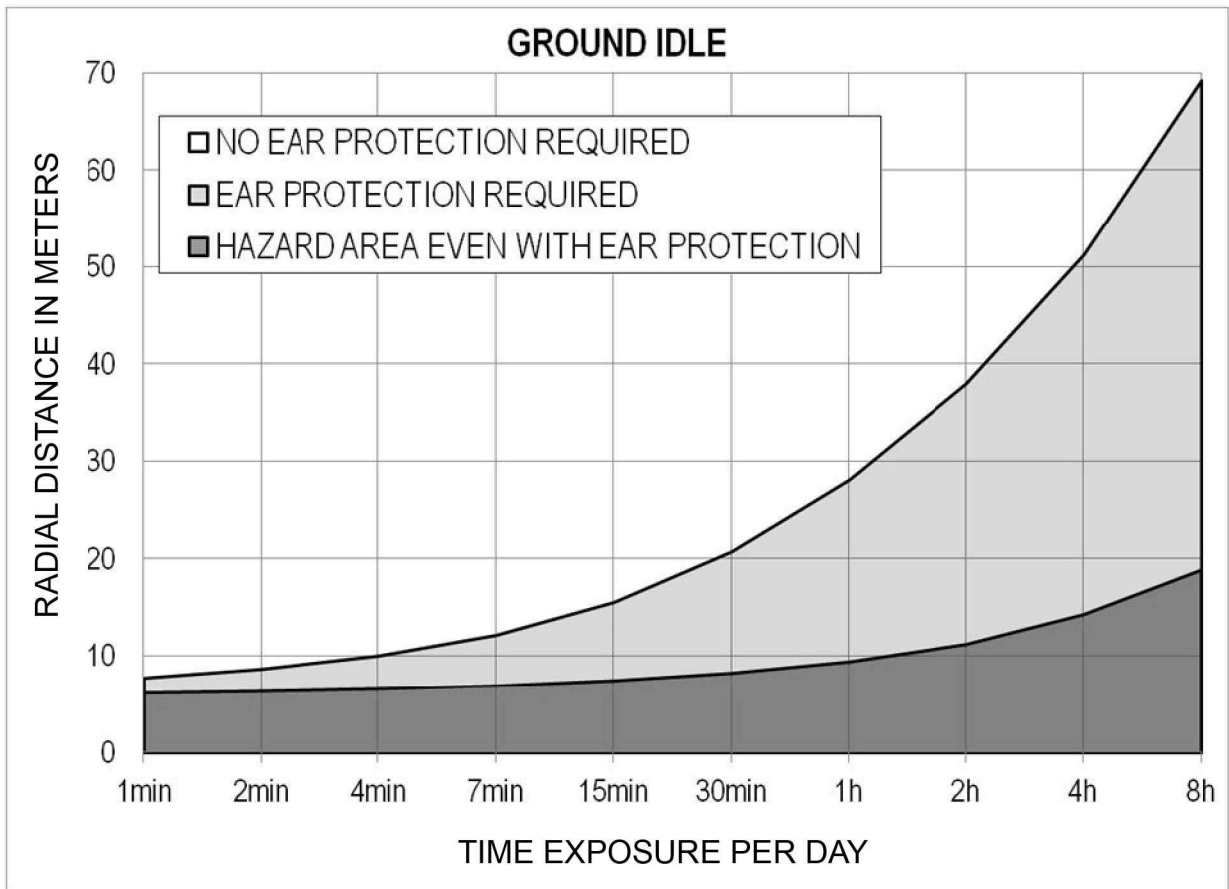

ICN-C919-A-192006-A-SVV19-10816-A-002-01

Figure 2 Engine Acoustic Hazard Area - Ground Idle Thrust (Sheet 1 of 1)

Applicable to : ALL

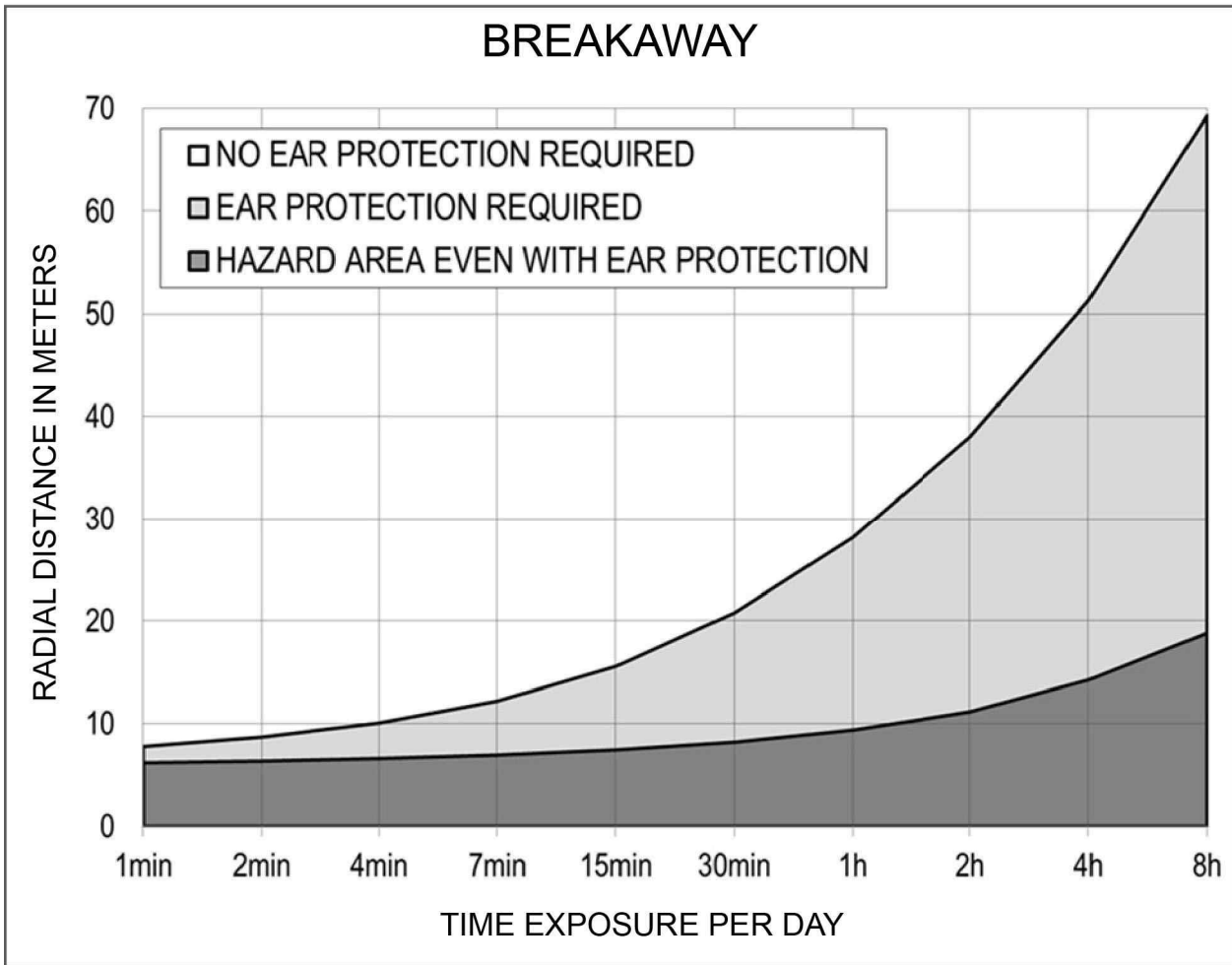

ICN-C919-A-192006-A-SVV19-10814-A-002-01

Figure 3 Engine Acoustic Hazard Area – Breakaway Thrust (Sheet 1 of 1)

Applicable to : ALL

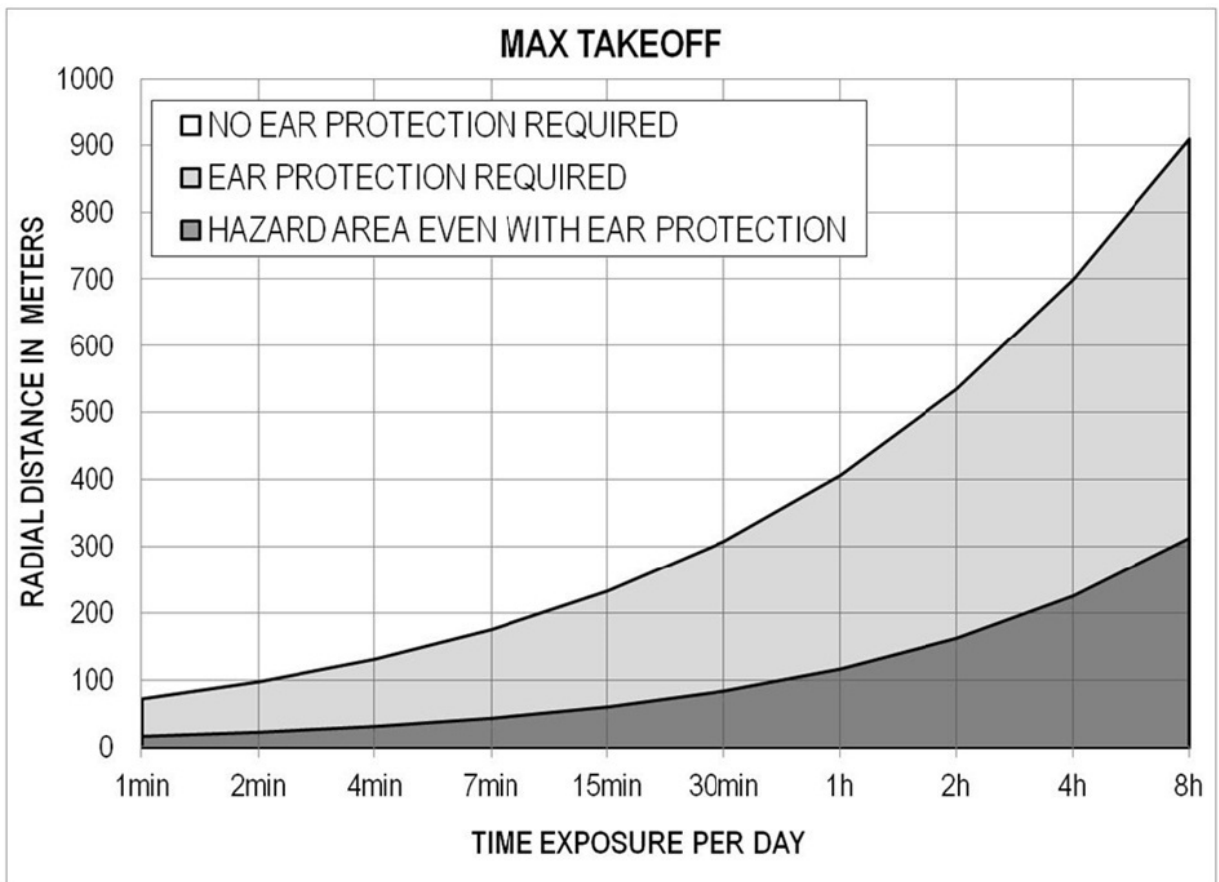

ICN-C919-A-192006-A-SVV19-10813-A-001-01

Figure 4 Engine Acoustic Hazard Area – Max Takeoff Thrust (Sheet 1 of 1)

Intentionally left blank



Jet Engine Exhaust Velocities and Danger Areas

Applicable to : ALL

C919 LEAP-1C VELOCITY HAZARD AREAS
 Ground Idle Operational, SLS, ISA+72F, WAI Off, FN=2,335lbf
 With Ground Plane (73.1 IN From Engine Centerline)

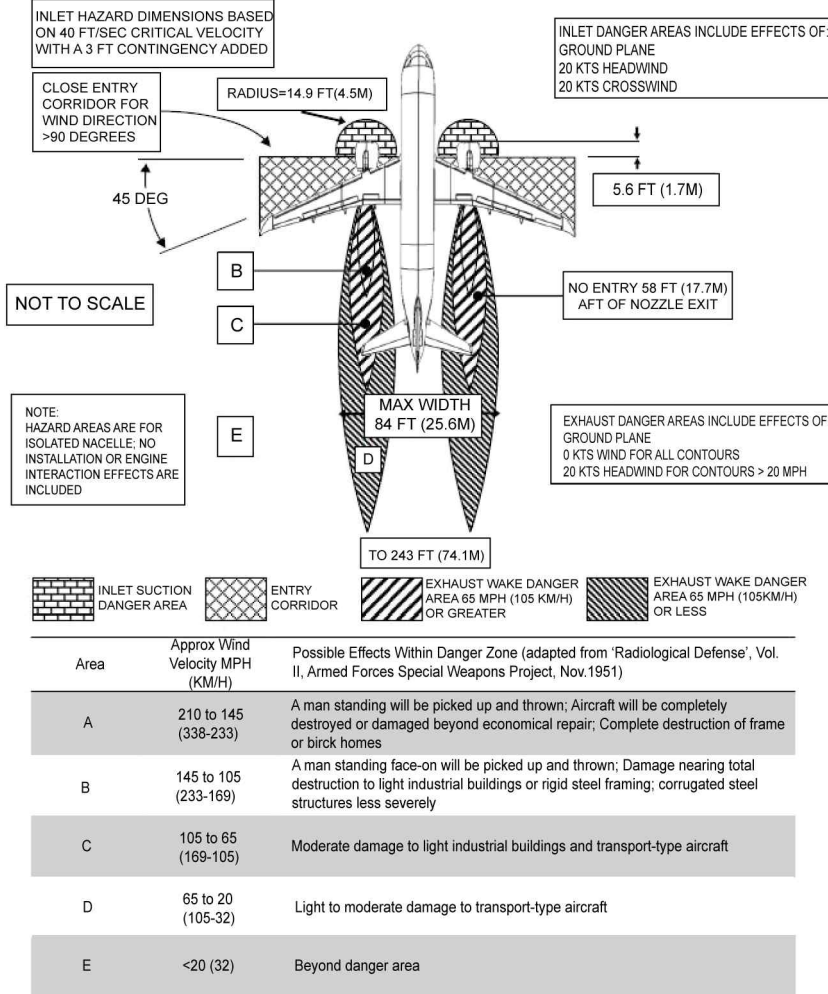

ICN-C919-A-192006-A-SVV19-10845-A-002-01

Figure 1 Engine Physical Hazard Areas – Ground Idle - Exhaust Velocities (Sheet 1 of 1)

Applicable to : ALL

C919 LEAP-1C VELOCITY HAZARD AREAS

Two-Engine Breakaway, SLS, ISA+72F, FN=7,329lbf
With Ground Plane (73.1 IN From Engine Centerline)

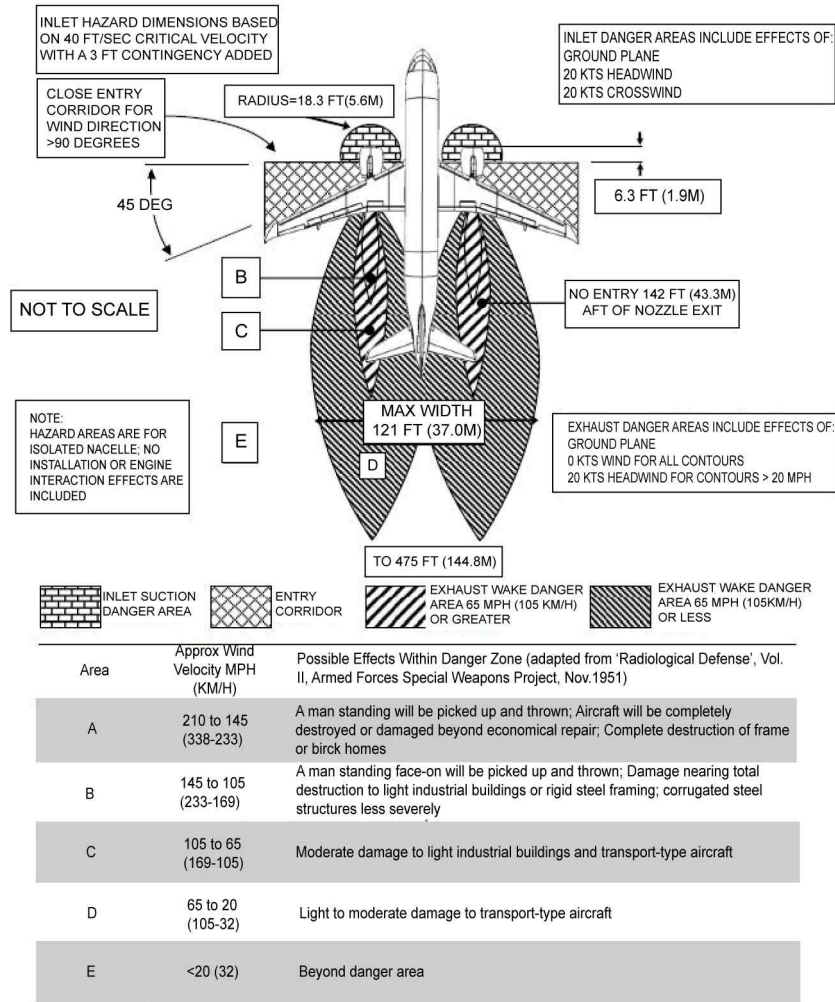

ICN-C919-A-192006-A-SVV19-10848-A-002-01

Figure 2 Engine Physical Hazard Areas – Two-Engine Breakaway - Exhaust Velocities (Sheet 1 of 1)

Aircraft Characteristics for Airport Planning

Applicable to : ALL

C919 LEAP-1C VELOCITY HAZARD AREAS
 One-Engine Breakaway, SLS, ISA+72F, FN=14,657lbf
 With Ground Plane (73.1 IN From Engine Centerline)

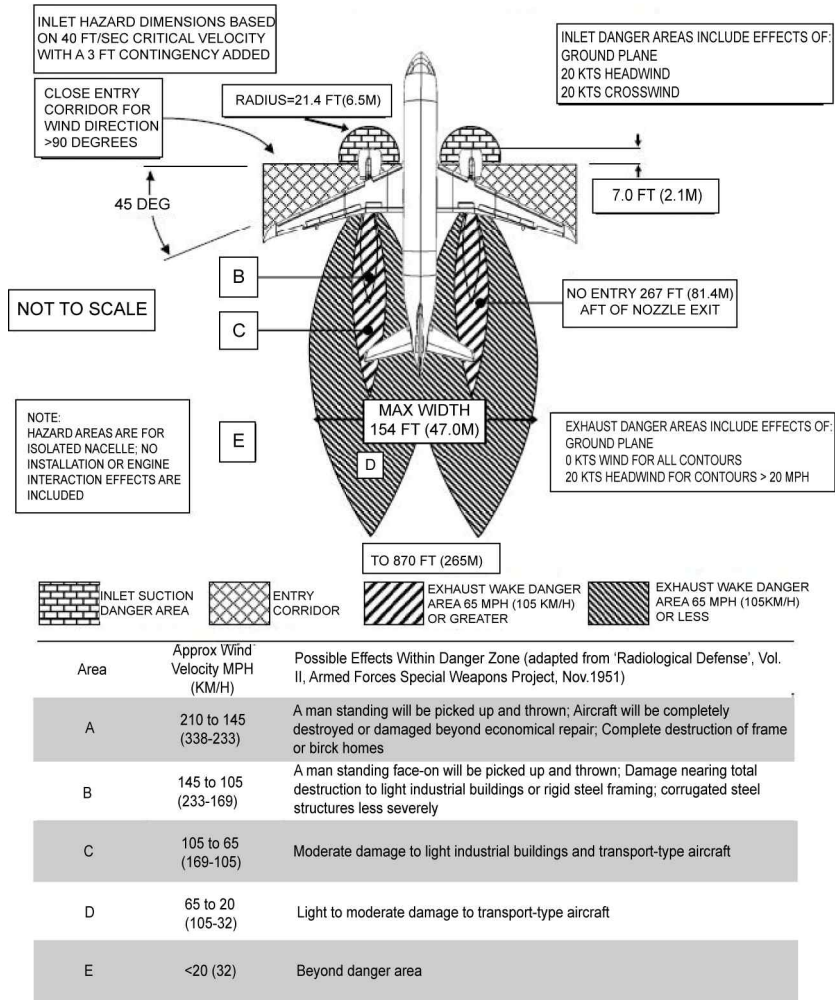

ICN-C919-A-192006-A-SVV19-10847-A-002-01

Figure 3 Engine Physical Hazard Areas – One-Engine Breakaway - Exhaust Velocities (Sheet 1 of 1)

Applicable to : ALL

C919 LEAP-1C VELOCITY HAZARD AREAS

Max TKOF, SLS, ISA+27F, FN=30,574lbf

With Ground Plane (73.1 IN From Engine Centerline)

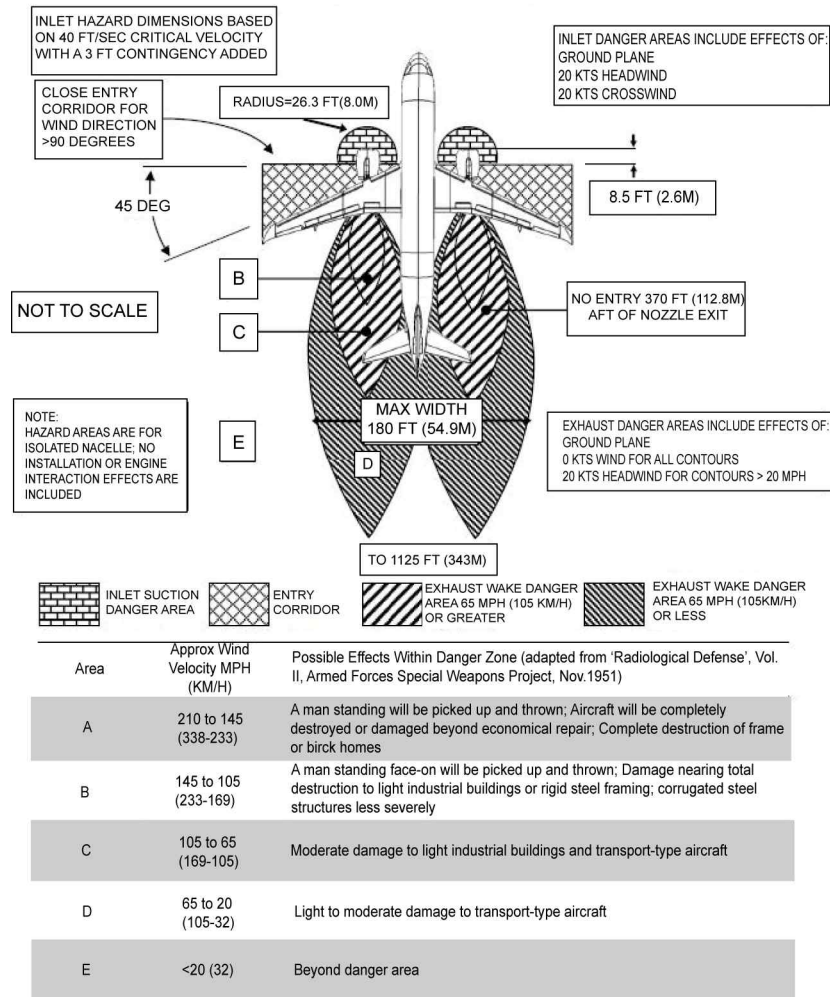

ICN-C919-A-192006-A-SVV19-10846-A-002-01

Figure 4 Engine Physical Hazard Areas – Max Takeoff - Exhaust Velocities (Sheet 1 of 1)

Intentionally left blank

APU Exhaust Velocities and Temperatures

This section gives APU exhaust velocities and temperatures.

Aircraft Characteristics for Airport Planning

Applicable to : ALL

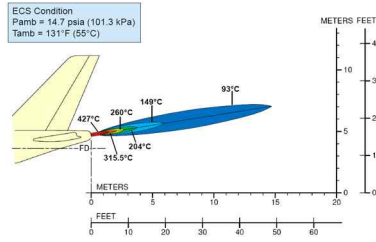

ICN-C919-A-192006-A-SVV19-64986-A-001-01

Figure 1 Plime-Temperature Contours (Sheet 1 of 2)

Applicable to : ALL

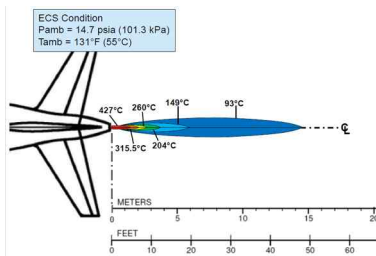

ICN-C919-A-192006-A-SVV19-64987-A-001-01

Figure 1 Plime-Temperature Contours (Sheet 2 of 2)

Applicable to : ALL

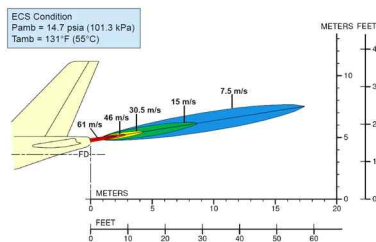

ICN-C919-A-192006-A-SVV19-64988-A-001-01

Figure 2 Plime-Velocity Contours (Sheet 1 of 2)

Applicable to : ALL

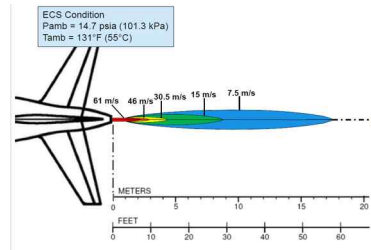

ICN-C919-A-192006-A-SVV19-64989-A-001-01

Figure 2 Plume-Velocity Contours (Sheet 2 of 2)

Intentionally left blank

Chapter 07

Pavement Data

Intentionally left blank

contents

<u>Document title</u>	<u>Data module code</u>	<u>Number of pages</u>	<u>Applicable to</u>
07 Pavement Data			
General Information	C919-A-19-20-07-01A-04AA-A	1	ALL
Landing Gear Footprint	C919-A-19-20-07-02A-04AA-A	1	ALL
Maximum Pavement Loads	C919-A-19-20-07-03A-04AA-A	1	ALL
Landing Gear Loading on Pavement	C919-A-19-20-07-04A-04AA-A	1	ALL
Flexible Pavement Requirements	C919-A-19-20-07-05A-04AA-A	1	ALL
Flexible Pavement Requirements LCN Conversion	C919-A-19-20-07-06A-04AA-A	1	ALL
Rigid Pavement Requirements Portland Cement Association(PCA)	C919-A-19-20-07-07A-04AA-A	1	ALL
Rigid Pavement Requirements LCN Conversion	C919-A-19-20-07-08A-04AA-A	1	ALL
ACN/PCN Reporting System - Flexible and Rigid Pavements	C919-A-19-20-07-09A-04AA-A	1	ALL
ACR/PCR Reporting System	C919-A-19-20-07-10A-04AA-A	1	ALL

Intentionally left blank

General Information

A brief description of the pavement charts that follow will help in their use for airport planning. Each aircraft configuration is depicted with a minimum range of multiple loads imposed on the main landing gear to aid in interpolation between the discrete values shown. All curves for any single chart represent data based on rated loads and tire pressures considered normal and acceptable by current aircraft tire manufacturer's standards. Tire pressures, where specifically designated on tables and charts, are at values obtained under loaded conditions as certificated for commercial use.

Section 07-02 presents basic data on the landing gear footprint configuration, maximum design taxi loads, and tire sizes and pressures.

Maximum pavement loads for certain critical conditions at the tire-to-ground interface are shown in Section 07-03, with the tires having equal loads on the struts.

The charts in Section 07-04 are provided in order to determine these loads throughout the stability limits of the aircraft at rest on the pavement.

The flexible pavement design curves (Section 07-05) are based on procedures set forth in Instruction Report No. S-77-1, "Procedures for Development of CBR Design Curves," dated June 1977. The line showing 10,000 coverages is used to calculate Aircraft Classification Number (ACN).

All Load Classification Number (LCN) curves (Sections 07-06 and 07-08) have been developed from a computer program based on data provided in International Civil Aviation Organization (ICAO) document 7920-AN/865/2, Aerodrome Design Manual, Part 2 ("Airport Physical Characteristics", Second Edition, 1965).

Rigid pavement design curves (Section 07-07) have been prepared with the Westergaard equation in general accordance with the procedures outlined in the Design of Concrete Airport Pavement (1973 edition) and Computer Program for Airport Pavement Design (1967 edition), published by the Portland Cement Association.

The ACN/PCN system (Section 07-09) as referenced in ICAO Annex 14, "Aerodromes", provides a standardized international aircraft/pavement rating system. ACN is the Aircraft Classification Number and PCN is the Pavement Classification Number. An aircraft having an ACN equal to or less than the PCN can operate on the pavement subject to no limitation on the tire pressure. Numerically, the ACN is two times the derived single-wheel load expressed in thousands of kilograms, where the derived single wheel load is defined as the load on a single tire inflated to 1.25 MPa (181 psi) that would have the same pavement requirements as the aircraft. Computationally, the ACN/PCN system uses the PCA program PDILB for rigid pavements and S-77-1 for flexible pavements to calculate ACN values. The method of pavement evaluation is left up to the airport with the results of their evaluation presented as follows:

PCN			
Pavement Type	Subgrade Category	Tire Pressure Category	Evaluation Method
R = Rigid	A = High	W = No Limit	T = Technical
F = Flexible	B = Medium	X - ≤ 1.5 MPa (217 psi)	U = Using Aircraft
	C = Low	Y - ≤ 1 MPa (145 psi)	
	D = Ultra Low	Z - ≤ 0.5 MPa (73 psi)	



Aircraft Characteristics for Airport Planning

ACN values for flexible pavements are calculated for the following four subgrade categories:

- High Strength - CBR 15
- Medium Strength - CBR 10
- Low Strength - CBR 6
- Ultra Low Strength - CBR 3

ACN values for rigid pavements are calculated for the following four subgrade categories:

- High Strength, $k = 150 \text{ MN/m}^3$ (550 pci)
- Medium Strength, $k = 80 \text{ MN/m}^3$ (300 pci)
- Low Strength, $k = 40 \text{ MN/m}^3$ (150 pci)
- Ultra Low Strength, $k = 20 \text{ MN/m}^3$ (75 pci)

The ACR/PCR method comes from aerodrome Design Manual released by the International Civil Aviation Organization (2022). ACR is the aircraft classification rating, and PCR is the corresponding pavement classification rating. Aircraft whose ACR is less than or equal to PCR can Operations on the pave without restriction under this tire pressure. In terms of value, ACR is twice the equivalent single wheel load (in 100 kg). The equivalent single-wheel load is the load of a single tire inflated to 1.50MPa (218psi). In this case, the track requirements of the tire are the same as those of the Aircraft tire. In terms of calculation, the ACR/PCR method uses the ICAO-ACR program recommended by the International Civil Aviation Organization (ICAO) to calculate the ACR values on the rigid and flexible pavement surfaces. Aerodrome authorities must determine the pavement analysis method, and the evaluation result of PCR are as follows:

PCR			
Pavement type	Classification	Tire Pressure category	Determination Method
R = Rigid	A = High	W - No pressure limit	T = Technical evaluation
F = Flexible	B = Medium	X - High Pressure limit is 1.75 MPa (254 psi)	U = Using aircraft experience
	C = Low	Y - Medium Pressure limit is 1.25 MPa (181 psi)	
	D = Ultra-low	Z - Low Pressure limit is 0.5 MPa (73 psi)	

For rigid and flexible pavement, ACR calculation under any weight is carried out according to these four types of base layer (E):

- A High strength, $E = 200\text{MPa}(29008 \text{ psi})$
- B Medium strength, $E = 120\text{MPa}(17405 \text{ psi})$
- C Low Strength, $E = 80\text{MPa}(11603 \text{ psi})$
- D Ultra-low Strength, $E = 50\text{MPa}(7252 \text{ psi})$

Landing Gear Footprint

Table 1 Landing Gear Footprint

Aircraft Model	Units	C919 STD	C919 ER
Maximum Taxi Weight	KG	75500	79300
Nose Gear Tire Size	IN	30×8.8R15/16PR	30×8.8R15/16PR
Nose Gear Tire Pressure(unloaded)	PSI	178	178
Main Gear Tire Size	IN	46×17R20/30PR	46×17R20/30PR
Main Gear Tire Pressure(unloaded)	PSI	187	196

Applicable to : ALL

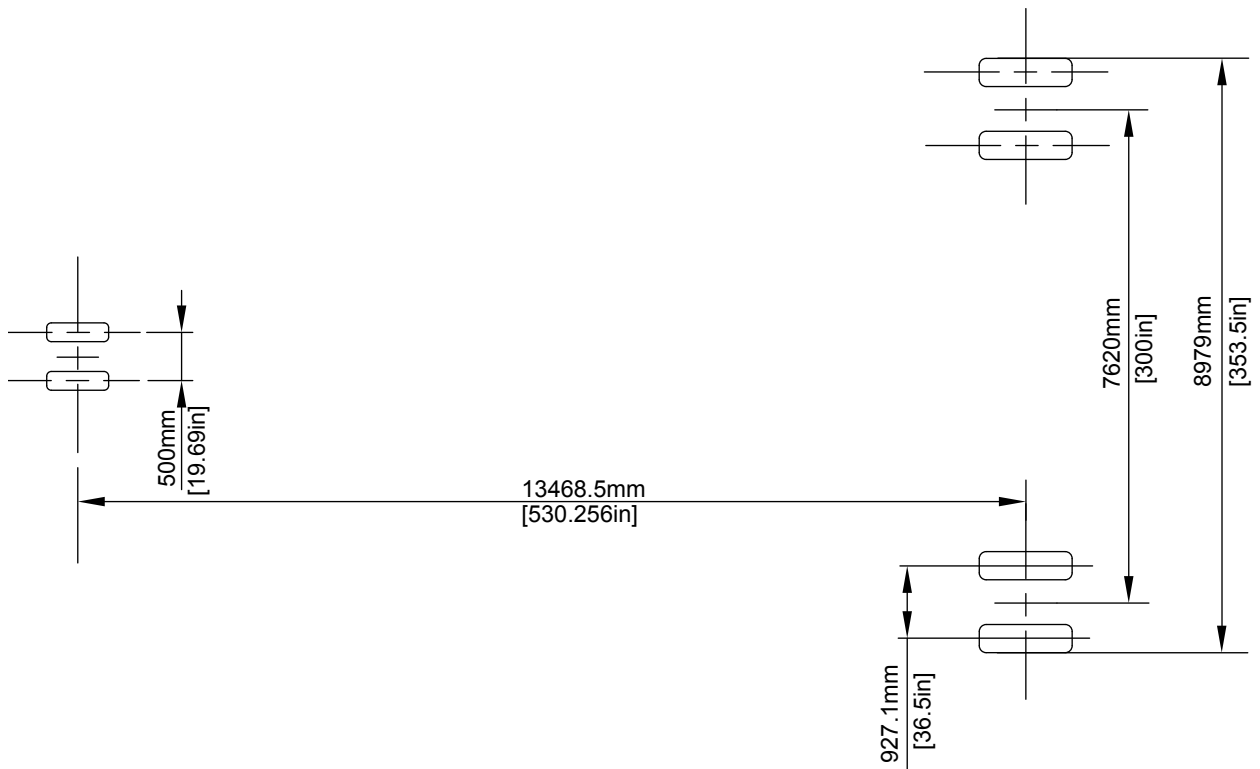

ICN-C919-A-192007-A-SVV19-10808-A-005-01

Figure 1 Landing Gear Footprint (Sheet 1 of 1)

Intentionally left blank

Maximum Pavement Loads

Applicable to : ALL



ICN-C919-A-192007-A-SVV19-23120-A-001-01

Figure 1 Maximum Pavement Load (Sheet 1 of 1)

Vng: Maximum vertical nose gear ground load at most forward center of gravity.

Vmg: Maximum vertical main gear ground load at most aft center of gravity.

H: Maximum horizontal ground load from braking.

NOTE: All loads calculated using aircraft maximum design taxi weight.

Model	Maximum Taxi Weight	Vng		Vmg (Single Landing Gear)	H (Single Landing Gear)	
		Static At Most Fwd c.g.	Steady Braking (Acceleration =-3 m/s ²)	Static At Most Aft c.g.	Steady Braking (Acceleration =-3 m/s ²)	Continuous Braking (μ= 0.8)
STD	75500 kg 166447 lb	9830 kg 21671 lb	14003 kg 30870 lb	34833 kg 76793 lb	113250 kg 249671 lb	28697 kg 63265 lb
ER	79300 kg 174825 lb	9143 kg 20158 lb	14708 kg 32424 lb	36712 kg 80935 lb	118950 kg 262237 lb	30245 kg 66677 lb

Intentionally left blank

Landing Gear Loading on Pavement

1. C919-STD:

Applicable to : ALL

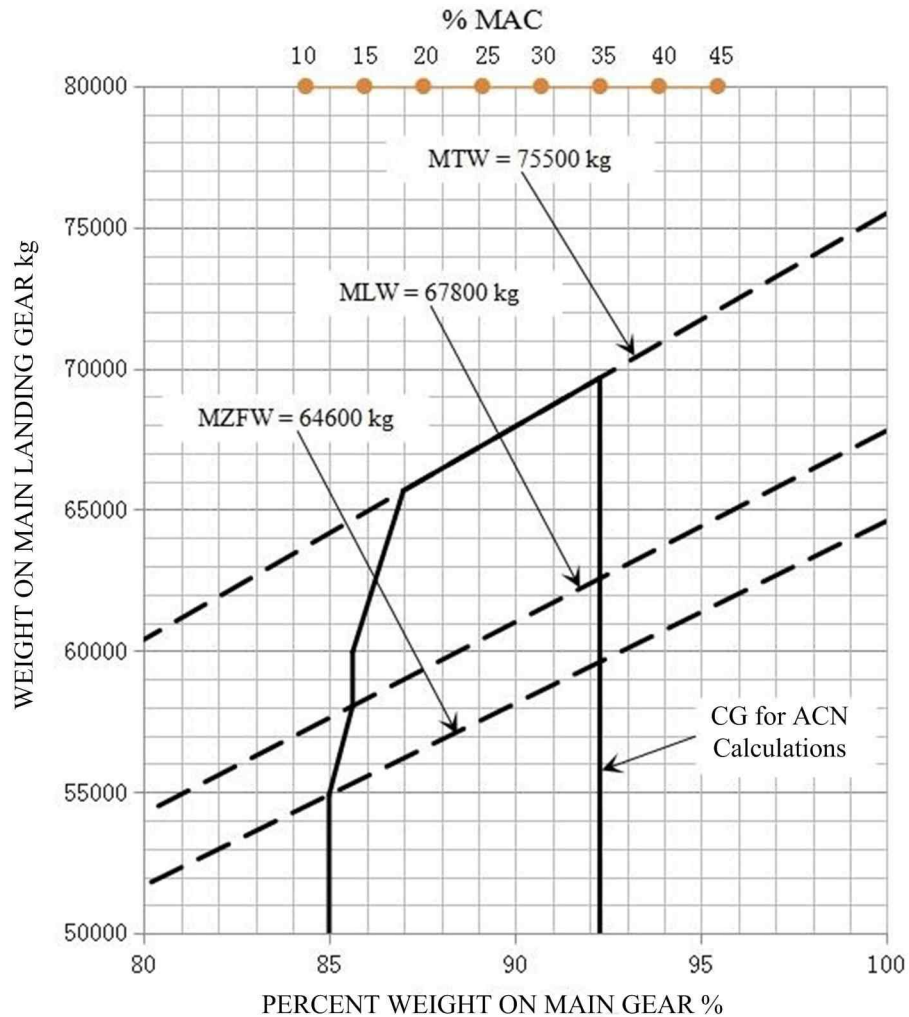

ICN-C919-A-192007-A-SVV19-23121-A-002-01

Figure 1 STD-Landing Gear Loading on Pavement (Sheet 1 of 1)

2. C919-ER:

Aircraft Characteristics for Airport Planning

Applicable to : ALL

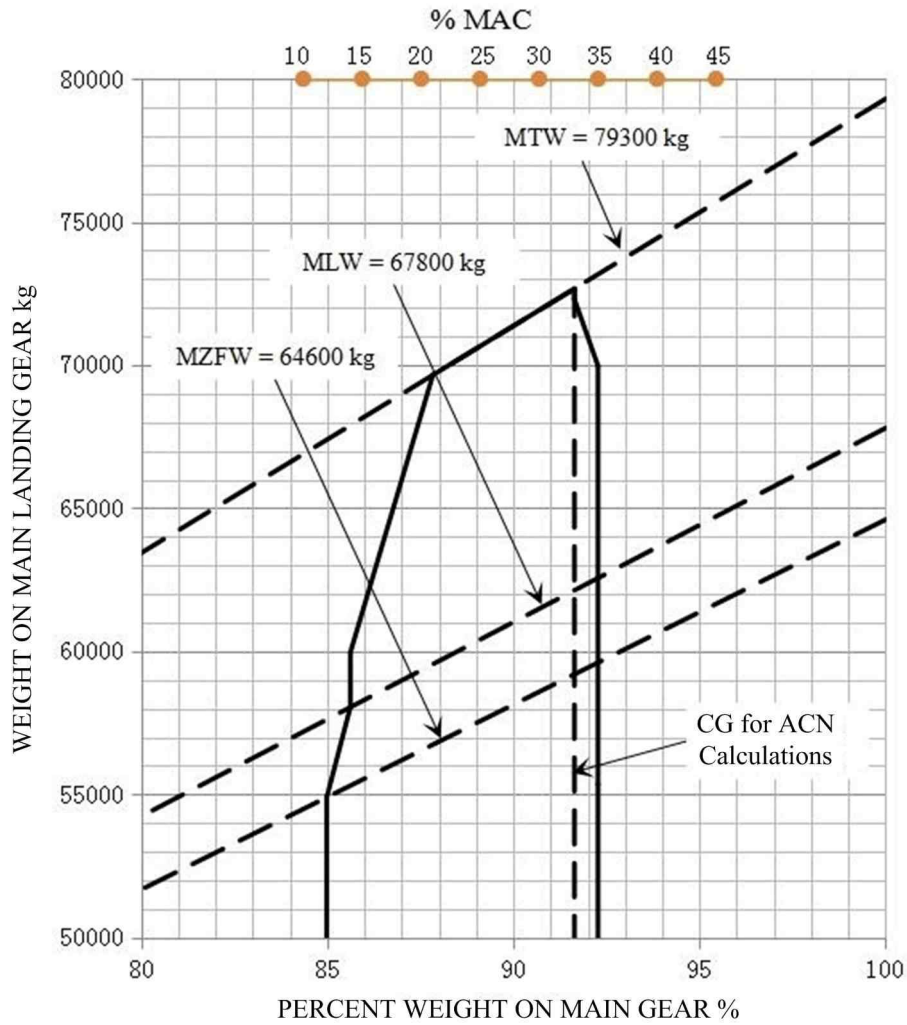

ICN-C919-A-192007-A-SVV19-23122-A-002-01

Figure 2 ER-Landing Gear Loading on Pavement (Sheet 1 of 1)

Flexible Pavement Requirements

To determine the flexible pavement thickness, the CBR, the annual departures and the main gear load must be known.

For example:

- CBR 7.
- Annual Departures 3000.
- Weight on Single Main Landing Gear 20000 kg (44092 lb).

For these conditions, flexible pavement thickness is at 46.7 cm (18.4 in).

1. C919-STD:

Applicable to : ALL

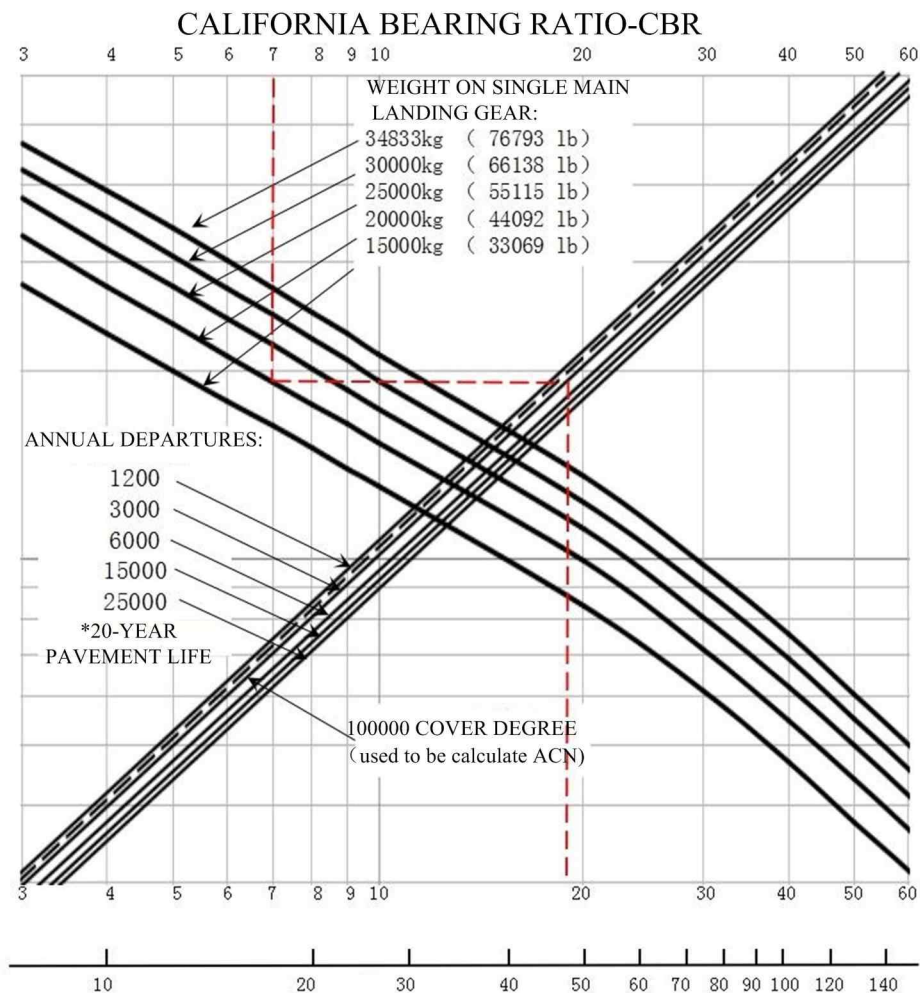

ICN-C919-A-192007-A-SVV19-23123-A-002-01

Figure 1 STD-Flexible Pavement Requirements (Sheet 1 of 1)

Aircraft Characteristics for Airport Planning

NOTE: The size of main landing gear tire is 46×17R20/30PR and tire pressure stays at 187 psi.

2. C919-ER:

Applicable to : ALL

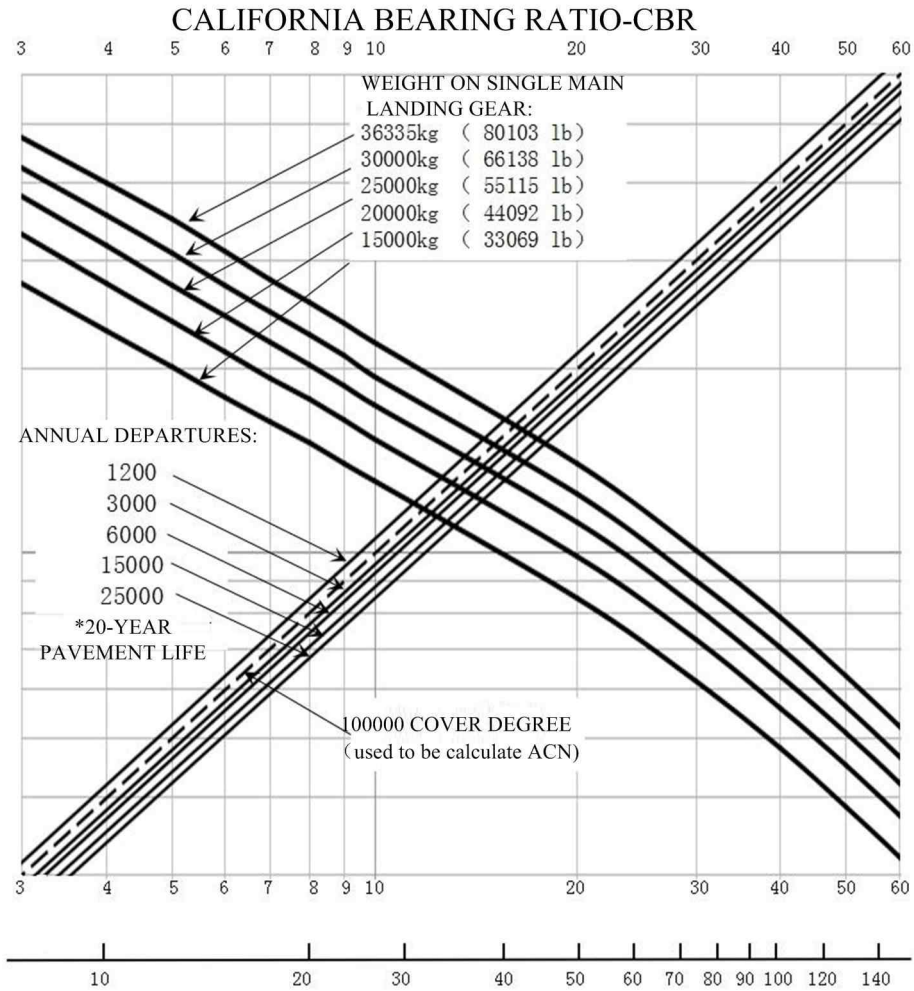

ICN-C919-A-192007-A-SVV19-23124-A-002-01

Figure 2 ER-Flexible Pavement Requirements (Sheet 1 of 1)

NOTE: The size of main landing gear tire is 46×17R20/30PR and tire pressure stays at 196 psi.

Flexible Pavement Requirements LCN Conversion

To determine the aircraft weight that can be accommodated on a particular flexible pavement, both the Load Classification Number (LCN) of the pavement and the thickness must be known.

For example:

- Flexible Pavement Thickness **50 cm (19.7 in)**.
- LCN 60.

For these conditions, the apparent maximum allowable weight permissible on the single main landing gear is **25000 kg (55115 lb)**.

1. C919-STD:

Applicable to : ALL

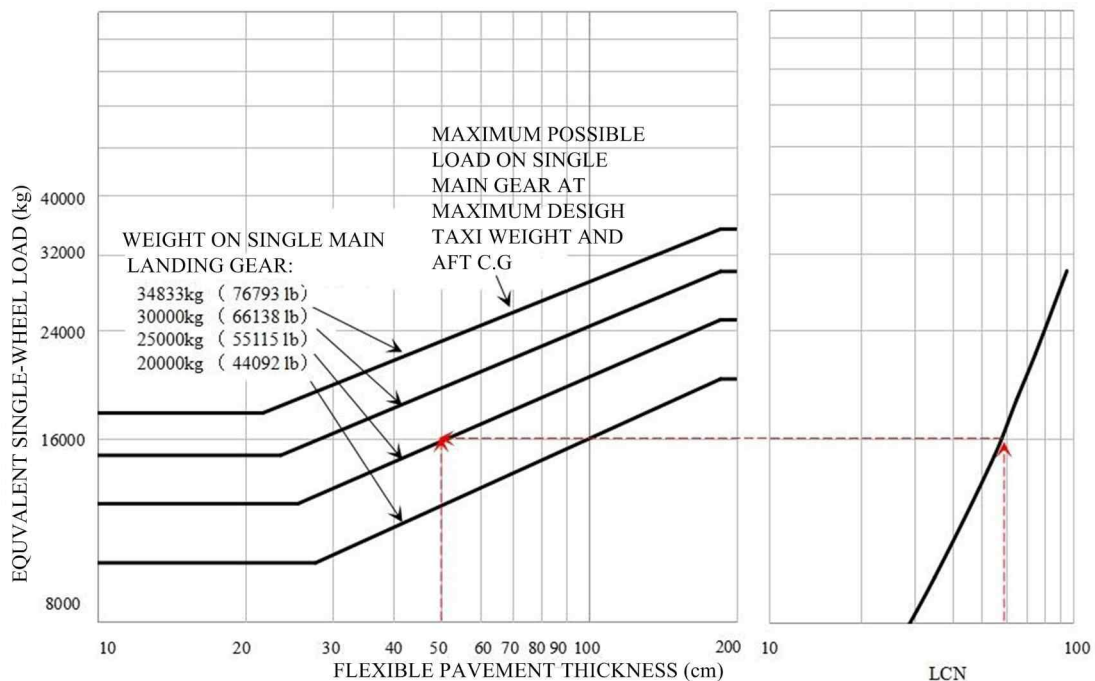

ICN-C919-A-192007-A-SVV19-23125-A-002-01

Figure 1 STD-Flexible Pavement LCN Conversion (Sheet 1 of 1)

NOTE: The size of main landing gear tire is 46×17R20/30PR and tire pressure stays at **187 psi**.

2. C919-ER:

Aircraft Characteristics for Airport Planning

Applicable to : ALL

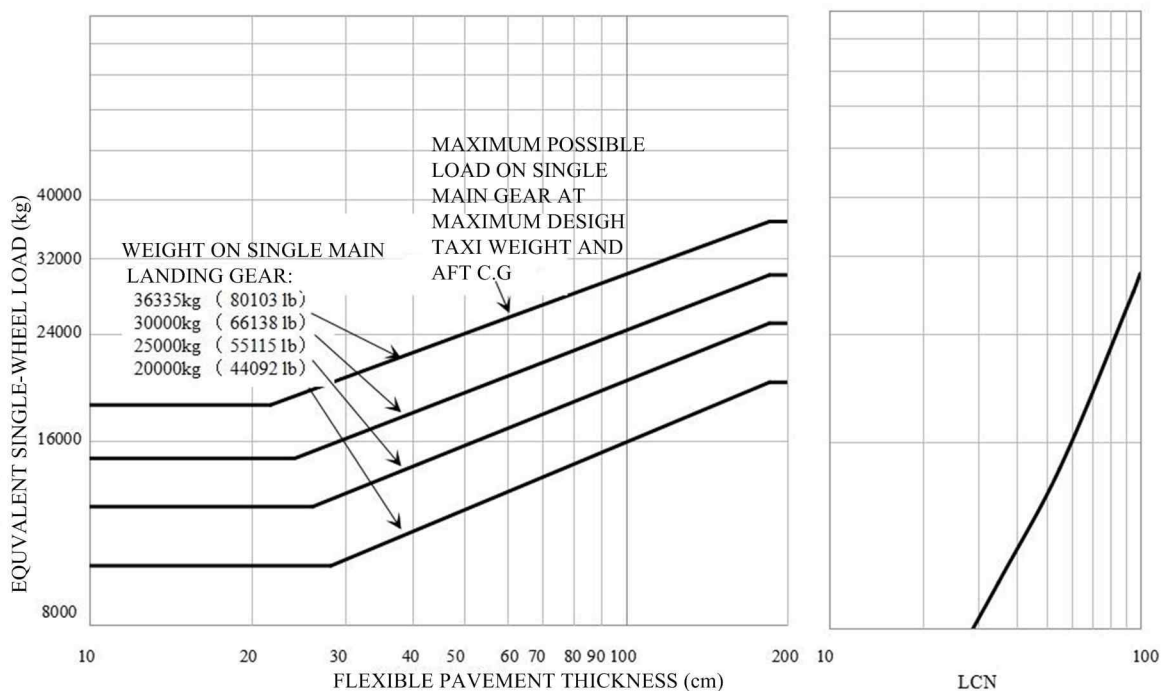

ICN-C919-A-192007-A-SVV19-23126-A-002-01

Figure 2 ER-Flexible Pavement LCN Conversion (Sheet 1 of 1)

NOTE: The size of main landing gear tire is 46×17R20/30PR and tire pressure stays at **196 psi** .

Rigid Pavement Requirements Portland Cement Association(PCA)

To determine the rigid pavement thickness, the subgrade strength (k), the allowable working stress and the weight on main landing gear must be known.

For example:

- Subgrade Strength $k = 80 \text{ MN/m}^3$ (300 lb/in^3).
- Allowable Working Stress 34 kgf/cm^2 (483.6 lbf/in^2).
- Weight on Single Main Landing Gear 35192 Kg (77584 Lb).

For these conditions, the rigid pavement thickness is 26.4 cm (10.4 in).

1. C919-STD:

Applicable to : ALL

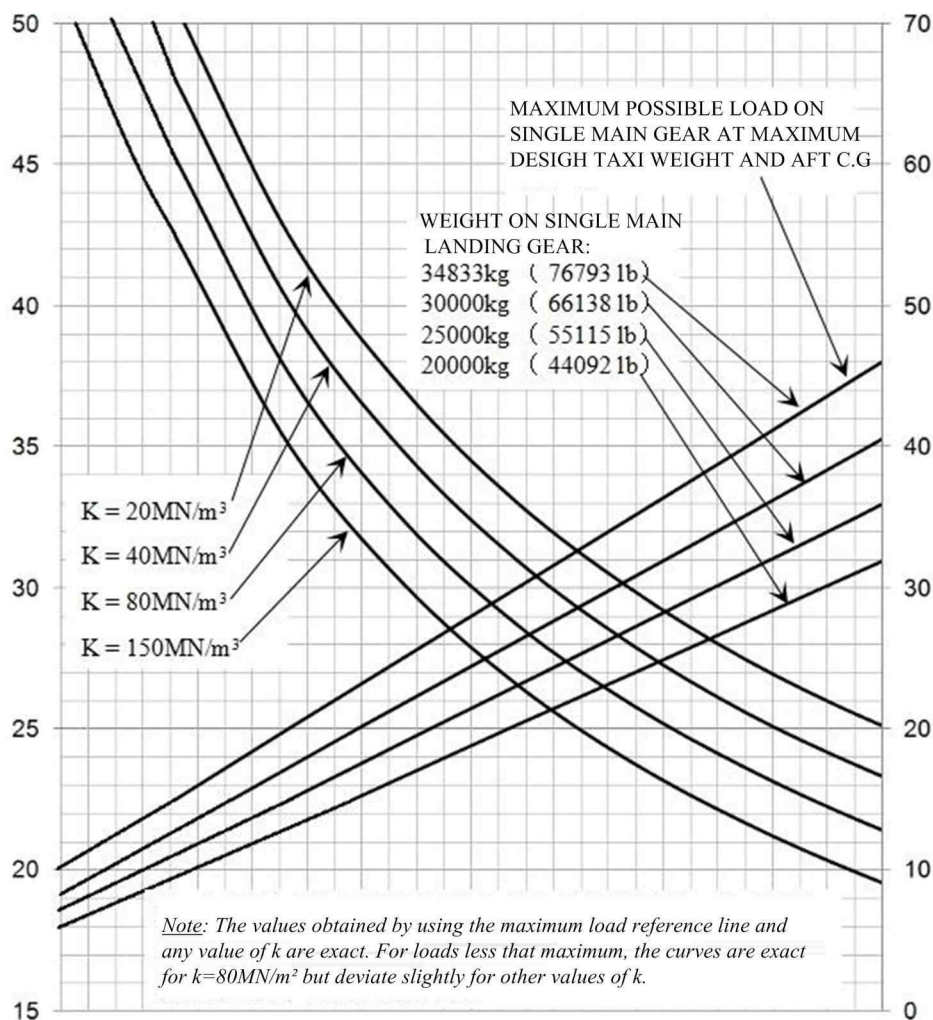

ICN-C919-A-192007-A-SVV19-23127-A-002-01

Figure 1 STD-Rigid Pavement Requirements (Sheet 1 of 1)

Aircraft Characteristics for Airport Planning

NOTE: The size of main landing gear tire is 46×17R20/30PR and tire pressure stays at 187 psi.

2. C919-ER:

Applicable to : ALL

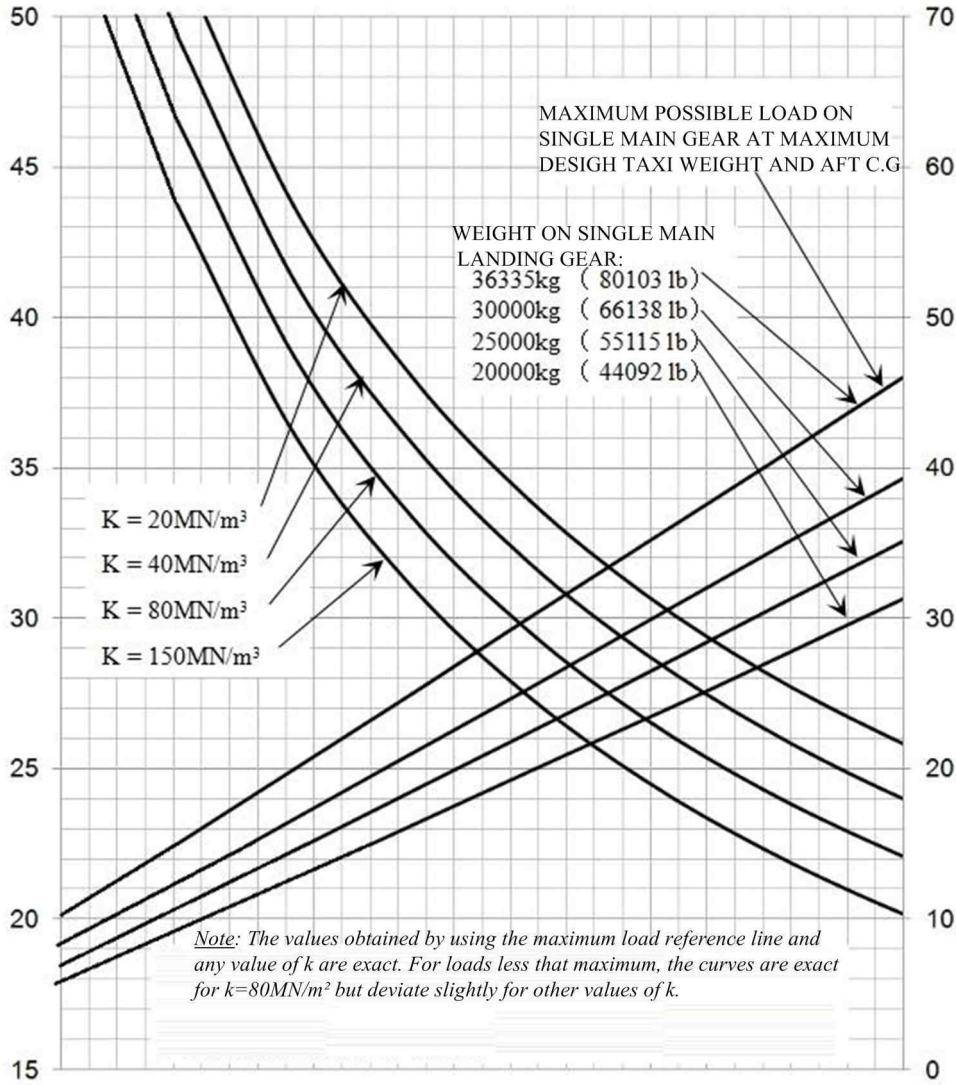

ICN-C919-A-192007-A-SVV19-23128-A-002-01

Figure 2 ER-Rigid Pavement Requirements (Sheet 1 of 1)

NOTE: The size of main landing gear tire is 46×17R20/30PR and tire pressure stays at 196 psi.



Rigid Pavement Requirements LCN Conversion

To determine the aircraft weight that can be accommodated on a particular rigid pavement, both the LCN of the pavement and the radius of relative stiffness (L) of the pavement must be known.

For example:

- LCN 42
- Radius of Relative Stiffness 76.2 cm (30 in)

For these conditions, the maximum allowable weight permissible on the main landing gear is 19082 kg (42069 lb).

Radius of Relative Stiffness (L) : $L = (Ed^3/12(1-\mu^2)k)^{1/4} = 24.1652(d^3/k)^{1/4}$, unit:in.

NOTE: E = 4×10^6 psi (YOUNG'S MODULUS)

k (SUBGRADE MODULUS, lbf/in³)

d (Rigid pavement thickness, in)

$\mu = 0.15$ (POISSON'S RATIO)

Table 1 Radius of Relative Stiffness Inquiry Table

d	k=75	k=100	k=150	k=200	k=250	k=300	k=350	k=400	k=500	k=550
6.00	31.48	29.30	26.47	24.63	23.30	22.26	21.42	20.72	19.59	19.13
6.50	33.43	31.11	28.11	26.16	24.74	23.64	22.74	22.00	20.80	20.31
7.00	35.34	32.89	29.72	27.65	26.15	24.99	24.04	23.25	21.99	21.47
7.50	37.22	34.63	31.29	29.12	27.54	26.32	25.32	24.49	23.16	22.61
8.00	39.06	36.35	32.85	30.57	28.91	27.62	26.58	25.70	24.31	23.74
8.50	40.88	38.04	34.37	31.99	30.25	28.91	27.81	26.90	25.44	24.84
9.00	42.67	39.71	35.88	33.39	31.58	30.17	29.03	28.08	26.55	25.93
9.50	44.43	41.35	37.36	34.77	32.89	31.42	30.23	29.24	27.65	27.00
10.00	46.18	42.97	38.83	36.14	34.17	32.65	31.42	30.39	28.74	28.06
10.50	47.90	44.57	40.28	37.48	35.45	33.87	32.59	31.52	29.81	29.11
11.00	49.60	46.16	41.71	38.81	36.71	35.07	33.75	32.64	30.87	30.14
11.50	51.28	47.72	43.12	40.13	37.95	36.26	34.89	33.74	31.91	31.16
12.00	52.94	49.27	44.52	41.43	39.18	37.44	36.02	34.84	32.95	32.17
12.50	54.59	50.80	45.90	42.72	40.40	38.60	37.14	35.92	33.97	33.17
13.00	56.22	52.32	47.27	43.99	41.61	39.75	38.25	36.99	34.99	34.16
13.50	57.83	53.82	48.63	45.26	42.80	40.89	39.35	38.06	35.99	35.14
14.00	59.43	55.31	49.98	46.51	43.98	42.02	40.44	39.11	36.99	36.12
14.50	61.02	56.78	51.31	47.75	45.16	43.15	41.51	40.15	37.97	37.08
15.00	62.59	58.25	52.63	48.98	46.32	44.26	42.58	41.19	38.95	38.03
15.50	64.15	59.70	53.94	50.20	47.47	45.36	43.64	42.21	39.92	38.98

Aircraft Characteristics for Airport Planning

d	k=75	k=100	k=150	k=200	k=250	k=300	k=350	k=400	k=500	k=550
16.00	65.69	61.13	55.24	51.41	48.62	46.45	44.70	43.23	40.88	39.92
16.50	67.23	62.56	56.53	52.61	49.75	47.54	45.74	44.24	41.84	40.85
17.00	68.75	63.98	57.81	53.80	50.88	48.61	46.77	45.24	42.78	41.78
17.50	70.26	65.38	59.08	54.98	52.00	49.68	47.80	46.23	43.72	42.70
18.00	71.76	66.78	60.34	56.15	53.11	50.74	48.82	47.22	44.66	43.61
19.00	74.73	69.54	62.84	58.48	55.31	52.84	50.84	49.17	46.51	45.41
20.00	77.66	72.27	65.30	60.77	57.47	54.91	52.84	51.10	48.33	47.19
21.00	80.55	74.96	67.74	63.04	59.62	56.96	54.81	53.01	50.13	48.95
22.00	83.41	77.63	70.14	65.28	61.73	58.98	56.75	54.89	51.91	50.69
23.00	86.24	80.26	72.52	67.49	63.83	60.98	58.68	56.75	53.67	52.41
24.00	89.04	82.86	74.87	69.68	65.90	62.96	60.58	58.59	55.41	54.11
25.00	91.81	85.44	77.20	71.84	67.95	64.92	62.46	60.41	57.14	55.79

1. C919-STD:

Applicable to : ALL

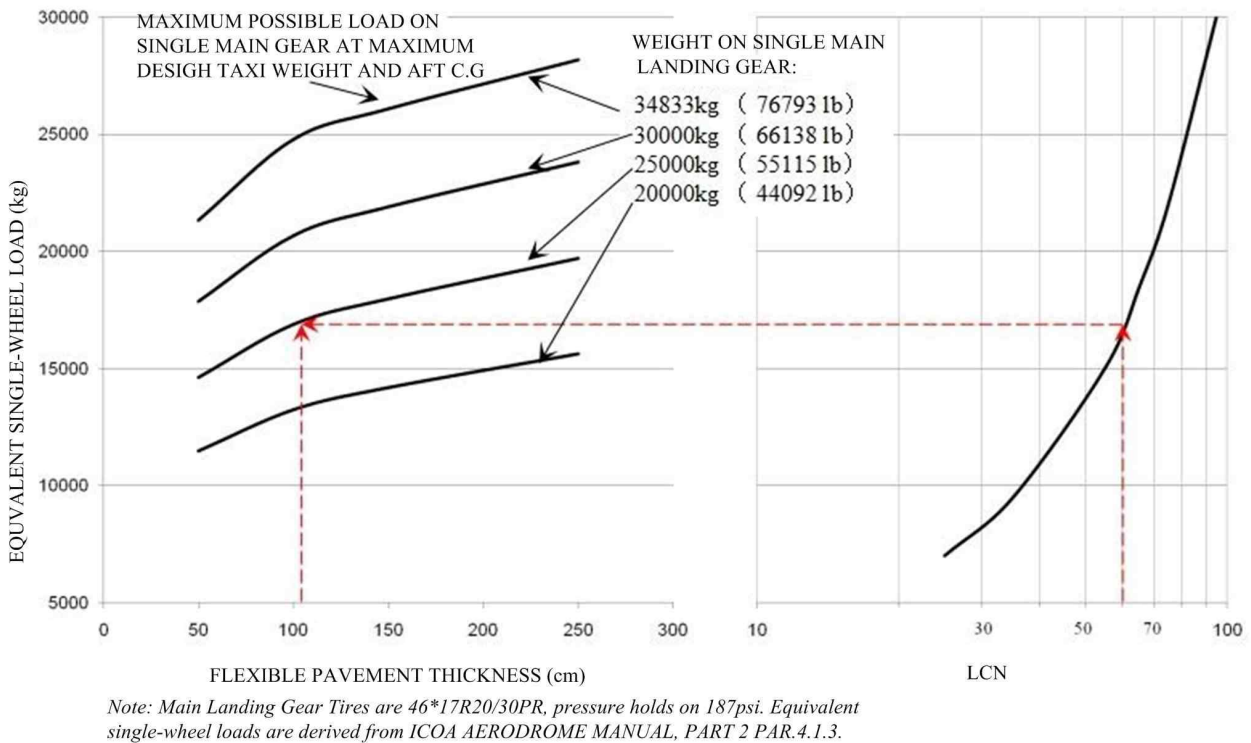

ICN-C919-A-192007-A-SVV19-23129-A-003-01

Figure 1 STD-Rigid Pavement LCN Conversion (Sheet 1 of 1)

2. C919-ER:

Applicable to : ALL

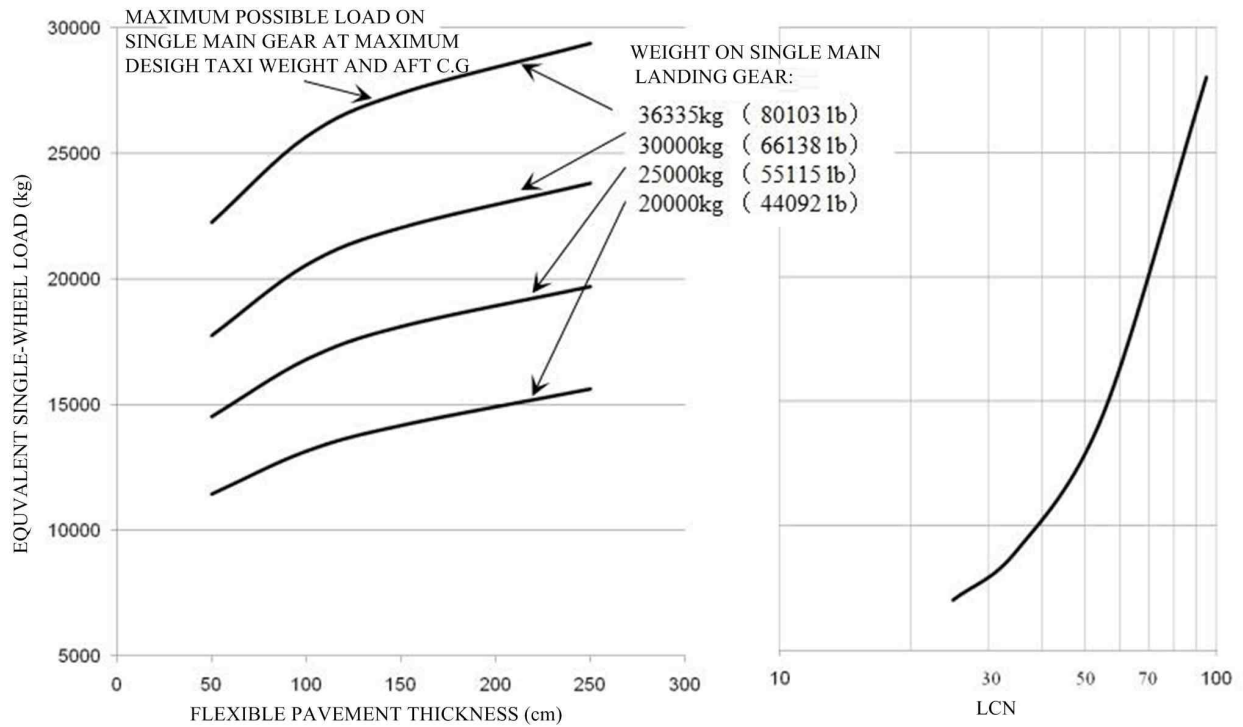

Note: Main Landing Gear Tires are 46*17R20/30PR, pressure holds on 187psi. Equivalent single-wheel loads are derived from ICAO AERODROME MANUAL, PART 2 PAR.4.1.3.

ICN-C919-A-192007-A-SVV19-23130-A-003-01

Figure 2 ER-Rigid Pavement LCN Conversion (Sheet 1 of 1)

This section above is about the radius of relative stiffness L calculated on this case of the Young's modulus of elasticity $E = 4 \times 10^6$ psi, Poisson's ratio $\mu = 0.15$. When the value of Young's modulus of elasticity E or Poisson's ratio μ equals other value, the value of originally obtained radius of relative stiffness L shall be multiplied by a coefficient.

For example:

- $E = 3 \times 10^6$ psi

In accordance with the query graph from Young's modulus of elasticity E to radius of relative stiffness L, it can determine coefficient of the Young's modulus of elasticity E to equal 0.931.

Similarly, it can determine the coefficient of Poisson's ratio μ .

Applicable to : ALL

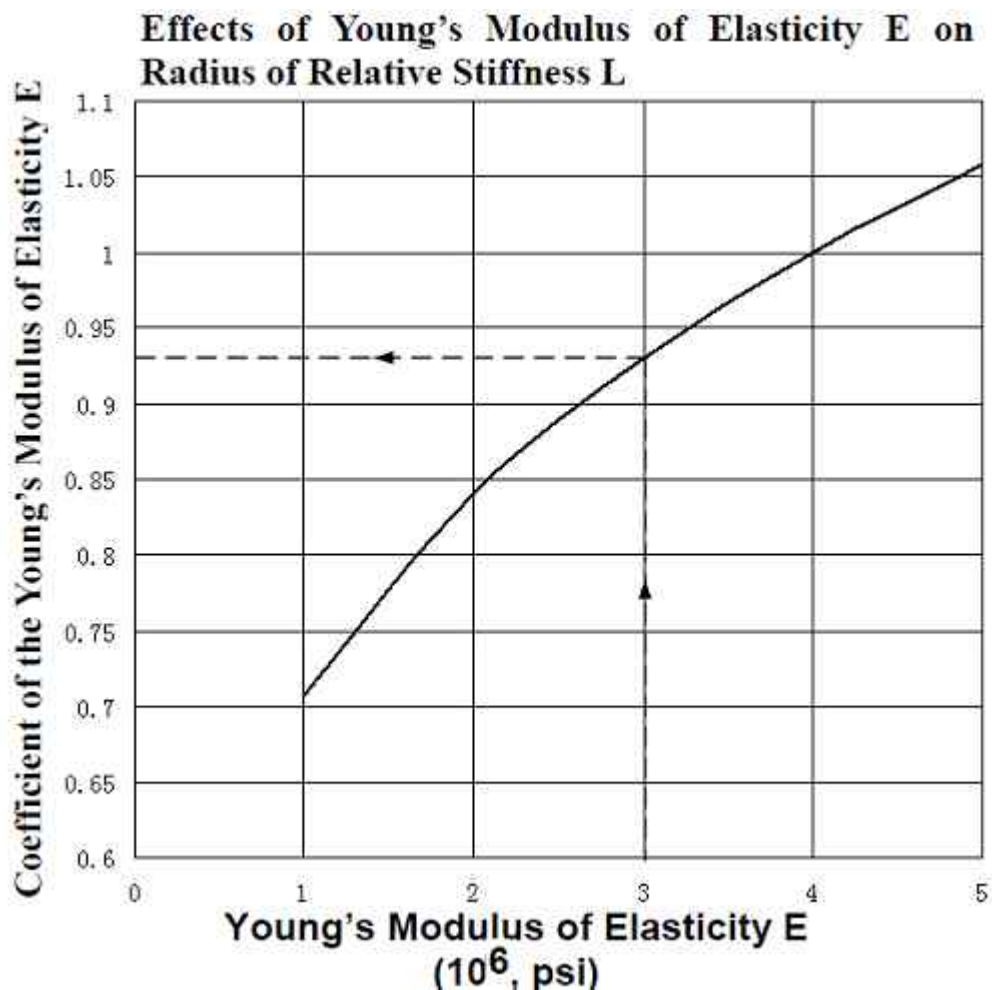

ICN-C919-A-192007-A-SVV19-23131-A-001-01

Figure 3 Young's modulus (Sheet 1 of 1)

Applicable to : ALL

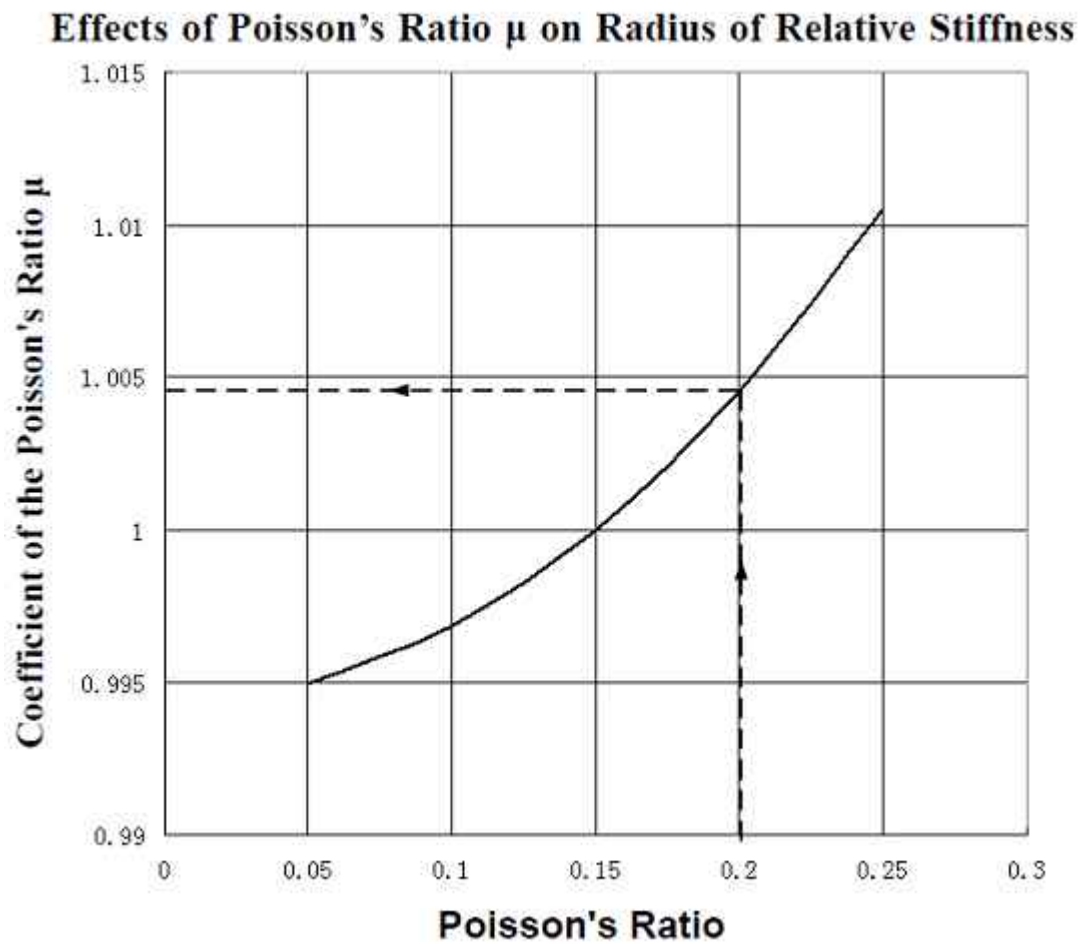

ICN-C919-A-192007-A-SVV19-23132-A-001-01

Figure 4 Poisson's Ratio (Sheet 1 of 1)

Intentionally left blank



ACN/PCN Reporting System - Flexible and Rigid Pavements

To determine the ACN of an aircraft on flexible or rigid pavement, both the aircraft gross weight and the subgrade strength category must be known.

NOTE: If the ACN of an aircraft is less than or equal to the PCN of a pavement, the aircraft can be operated on the pavement without limitation of tire inflation pressure.

The table below provides ACN data of C919 aircraft. If the ACN for an intermediate weight between Operating Empty Weight (OEW) and Maximum Taxi Weight (MTW) of the aircraft is required, the ACN data can be referred to the figures below.

Model	MTW/OEW kg/lb	Load on One MLG Leg %	Tire Pressure MPa/PSI	ACN for Rigid Pavement Subgrades – MN/m ³				ACN for Flexible Pavement Subgrades – CBR			
				High 150	Medi um 80	Low 40	Ultra Low 20	High 15	Medi um 10	Low 6	Ultra Low 3
STD	75500/ 166449.01	92.3%	1.29/187	42.9	45.5	48.0	50.1	38.1	39.7	44.5	50.4
	45700/ 100751.25	92.3%		23.7	25.2	26.8	28.1	21.8	22.0	23.9	27.7
ER	79300/ 174826.57	91.6%	1.35/196	45.8	48.3	50.9	53.0	40.4	42.3	47.1	53.0
	45700/ 100751.25	92.3%		24.1	25.5	27.1	28.3	21.8	22.1	23.9	27.8

1. C919-STD:

Aircraft Characteristics for Airport Planning

Applicable to : ALL

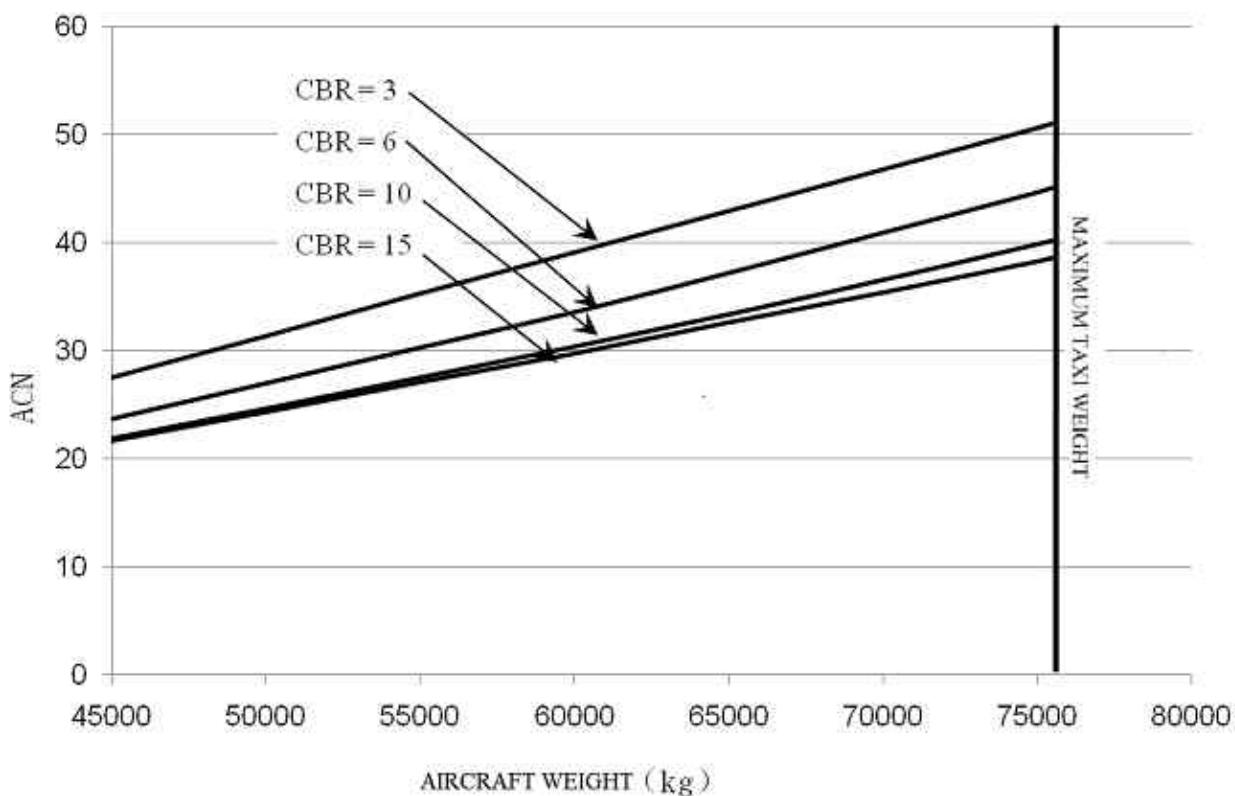

ICN-C919-A-192007-A-SVV19-23133-A-001-01

Figure 1 STD-ACN for flexible pavement (Sheet 1 of 1)

NOTE: The size of main landing gear tire is 46×17R20/30PR and tire pressure stays at 187 psi.

Applicable to : ALL

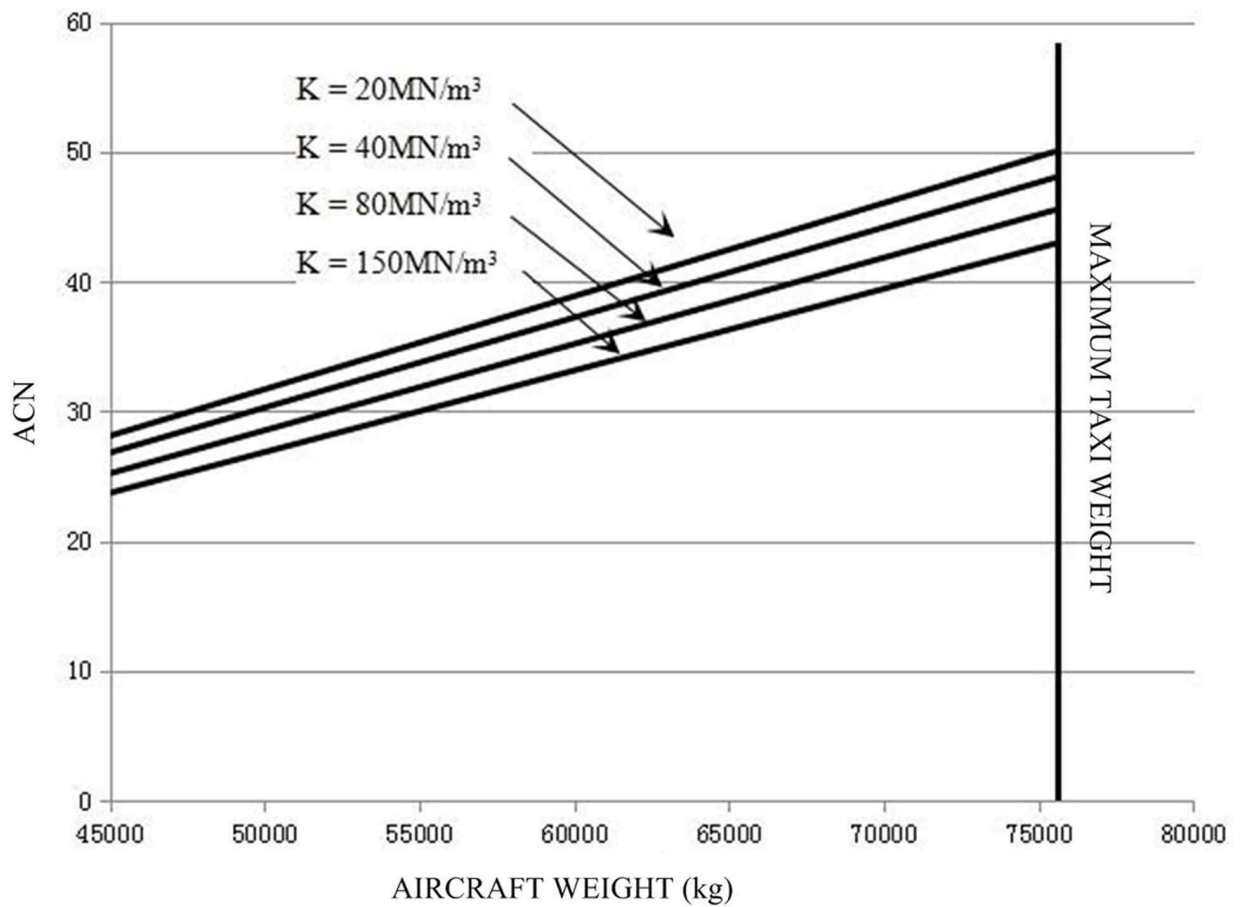

ICN-C919-A-192007-A-SVV19-23135-A-003-01

Figure 2 STD-ACN for rigid pavement (Sheet 1 of 1)

NOTE: The size of main landing gear tire is 46×17R20/30PR and tire pressure stays at 187 psi.

2. C919-ER:

Aircraft Characteristics for Airport Planning

Applicable to : ALL

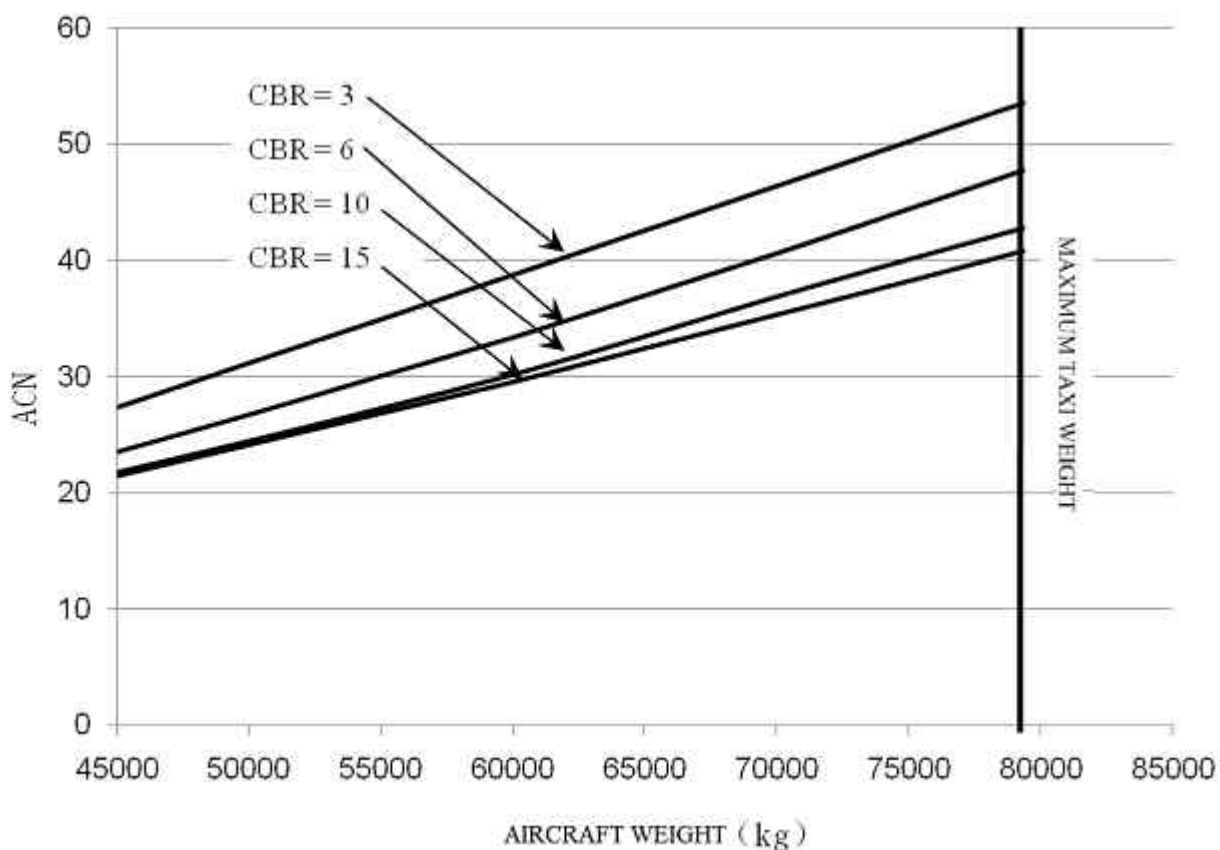

ICN-C919-A-192007-A-SVV19-23134-A-001-01

Figure 3 ER-ACN for flexible pavement (Sheet 1 of 1)

NOTE: The size of main landing gear tire is 46×17R20/30PR and tire pressure stays at 196 psi.



Applicable to : ALL

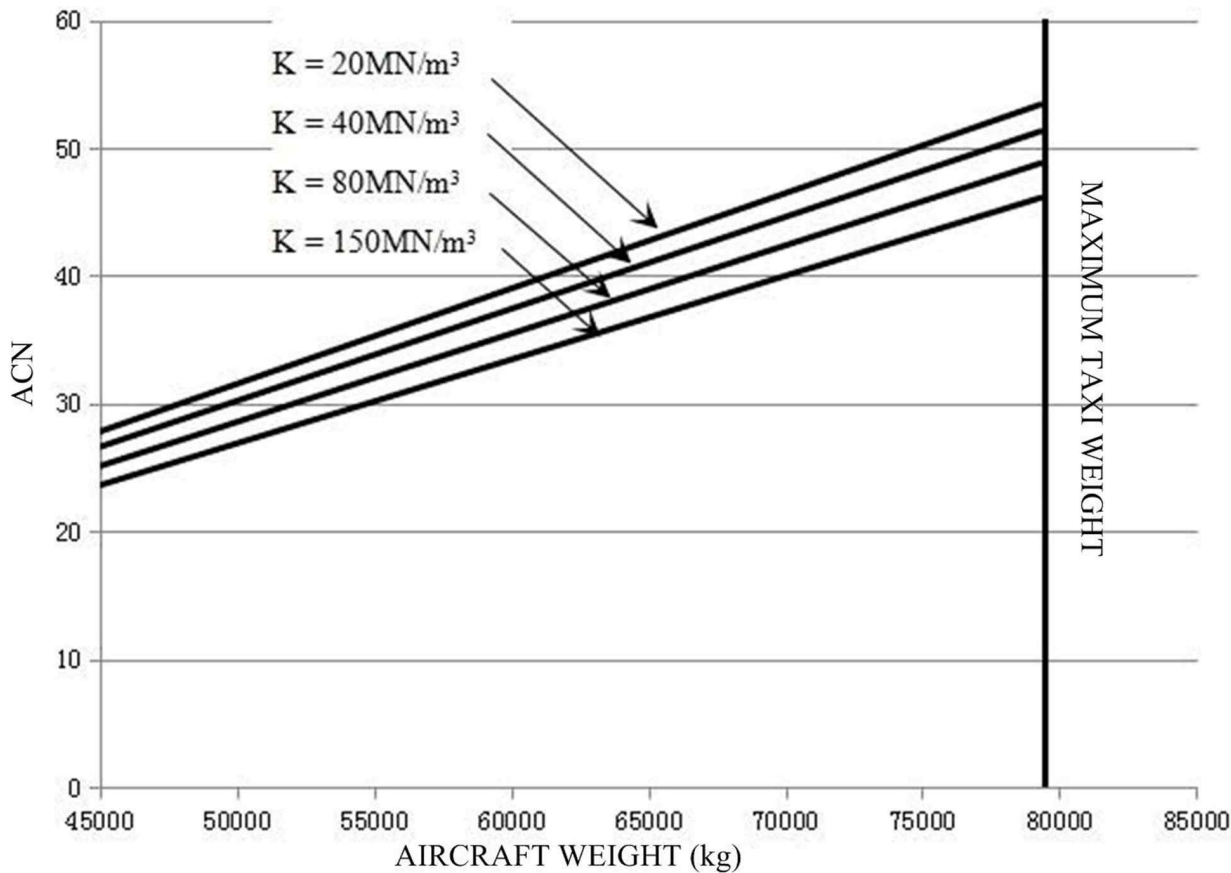

ICN-C919-A-192007-A-SVV19-23136-A-003-01

Figure 4 ER-ACN for rigid pavement (Sheet 1 of 1)

NOTE: The size of main landing gear tire is 46×17R20/30PR and tire pressure stays at 196 psi.

Intentionally left blank

ACR/PCR Reporting System

This section gives the ACR values for Aircraft on rigid and flexible surfaces with different roadbed strengths, as shown in Figure 1-4.

To calculate the ACR value of a Aircraft on the rigid and flexible pavement, you must also know the weight and circuit base strength of the Aircraft as. List 1 also gives the ACR value of the Aircraft in the form of List compartment. Approximately, the following linear interpolation formula can be used to get the ACR of the Aircraft under the calculated weight, as follows :

$$\text{Weight of ACR} = \text{ACR min} + (\text{ACR max} - \text{ACR min}) \times (\text{Weight of Operations} - 45000\text{kg}) / (\text{MTW} - 45000\text{kg})$$

Approximately, linear interpolation can be used to get the allowable Operations weight of a Aircraft under a given pavement PCR, as follows:

$$\text{Weight of operations} = 45000\text{kg} + (\text{MTW} - 45000\text{kg}) \times (\text{PCR} - \text{ACR min}) / (\text{ACR max} - \text{ACR min})$$

In the formula: The ACR max is the ACR value under the corresponding MTW. The ACR min is the ACR value at 45000kg.

NOTE: CG in the title of the figure is used for the calculation of ACR.

Model	MTW/ Minimum Weight (kg)	Main landing gear on one side Bearin g (%)	Main landing gear tire Tire Pressure (MPa)	ACR under rigid runway E-MPa				ACR under flexible runway E-MPa			
				High A 200	Midd le B 120	Low C 80	Ultr a- low D 50	High A 200	Midd le B 120	Low C 80	Ultr a- lowD 50
C919STD	75500	46.14	1.29	442	466	482	500	340	366	399	445
	45000	46.14	1.29	238	252	262	274	199	207	217	235
C919ER	79300	45.82	1.35	471	495	511	528	361	387	423	472
	45000	45.82	1.35	240	253	263	274	200	207	216	234

NOTE: The minimum weight is only used to generate ACR curve.

1. C919-STD:

Applicable to : ALL

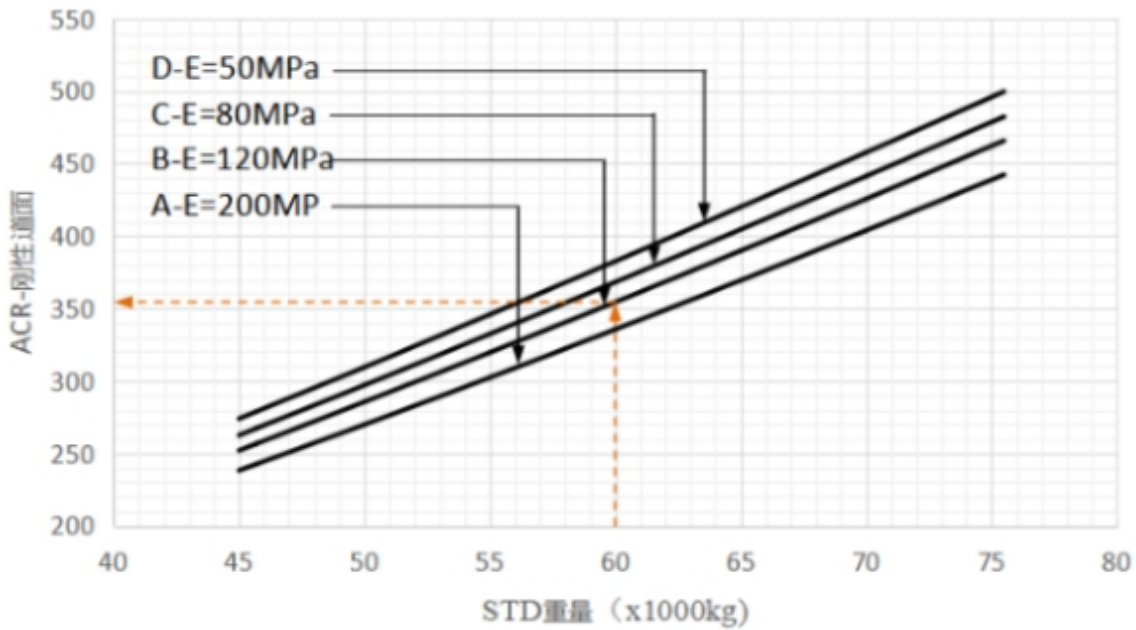

ICN-C919-A-192007-A-SVV19-86281-A-001-01

Figure 1 Type C919STD, ACR rigid pavement (MRW 75500kg,CG 35%MAC) (Sheet 1 of 1)

Applicable to : ALL

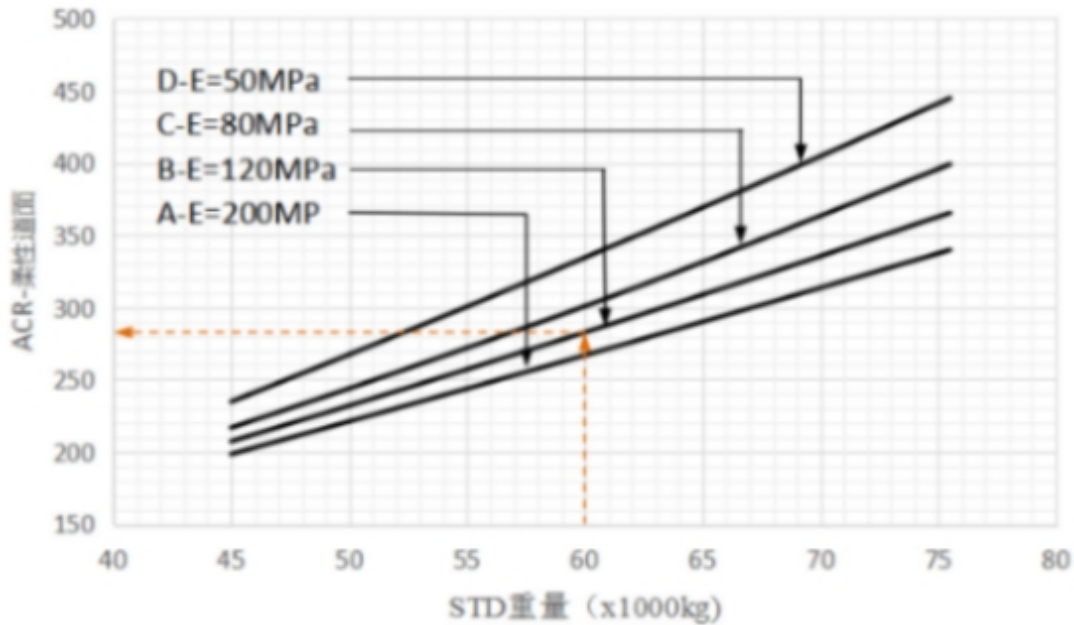

ICN-C919-A-192007-A-SVV19-86282-A-001-01

Figure 2 Type C919STD, ACR Flexible Roadway (MRW 75500kg,CG 35%MAC) (Sheet 1 of 1)



2. C919-ER:

Applicable to : ALL

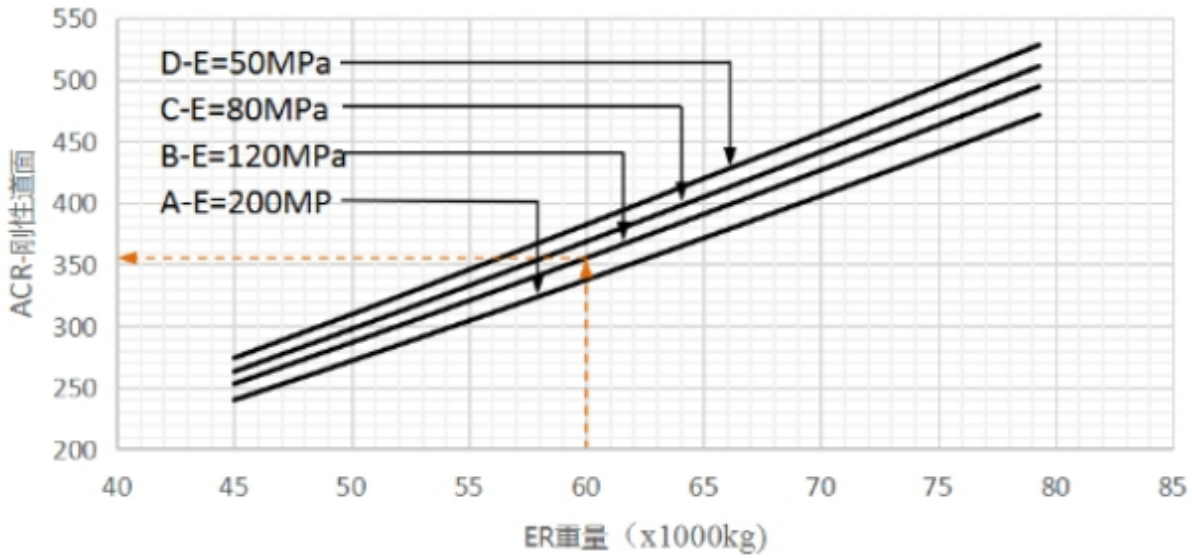

ICN-C919-A-192007-A-SVV19-86283-A-001-01

Figure 3 C919ER type ACR rigid pavement (MRW 79300kg,CG 33%MAC) (Sheet 1 of 1)

Applicable to : ALL

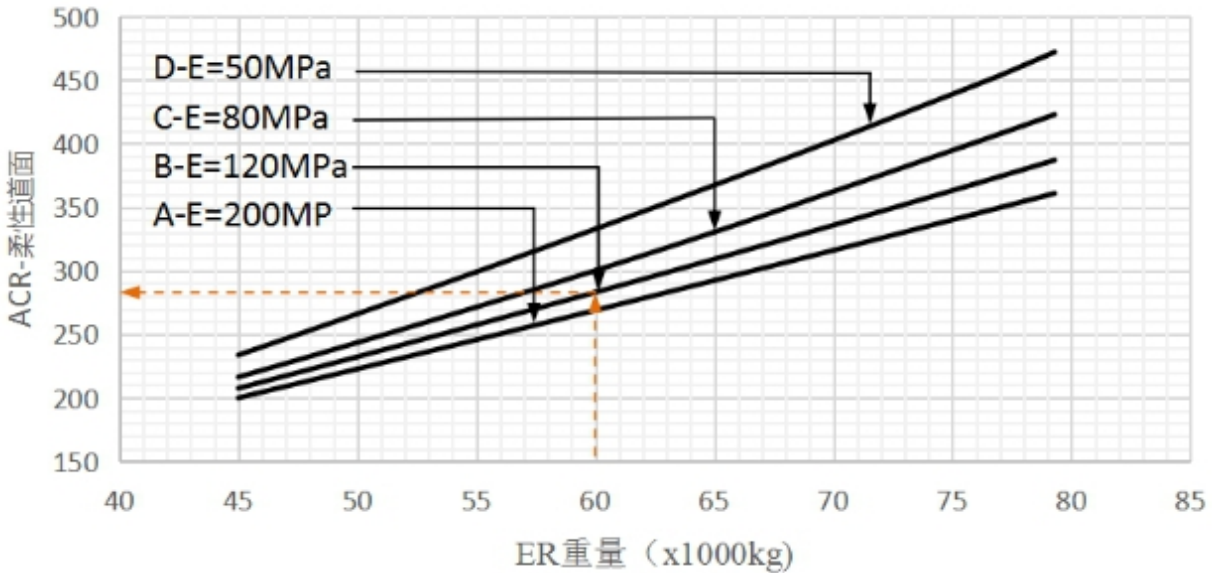

ICN-C919-A-192007-A-SVV19-86284-A-001-01

Figure 4 C919ER type ACR flexible pavement (MRW 79300kg,CG 33%MAC) (Sheet 1 of 1)