British Railways Board

Mechanical & Electrical Engineering Department

VEHICLE DIAGRAM BOOK NO 230

FOR

Diesel Electric Multiple Unit Trains

(Including H.S.T.)

© COPYRIGHT NOTICE

This PDF file has been created from the original book with permission of BRB Residuary Ltd who, retain copyright in the original document.

The original book was provided courtesy of Eddie Knorn.

This PDF version by David Faulkner, 2012.

Individuals may: use, retain and print out this PDF version for their private information or for that of their non-commercial enthusiast society or railway club.

This document and any copies produced from it in any form may not be sold or lent for any payment in any form other than to cover copying or transmission costs. No reproduction permitted in any other form or circumstance without prior permission from the original copyright holder



Contained in this book:

Design Code	Class	Vehicle Type	ex Diag	Issue	Date
DA201	210	DMS		1	Sep 80
DB201	201	DMBS	650	3	Dec 81
	202				
DB202	203	DMBS	651	3	Dec 81
	206				
	204				
DB203	205	DMBS	652	2	Dec 81
	205/1				
DB204	205	DMBS	656	3	Dec 85
DB205	207	DMBS	655	1	Sep 80
DB206	210	DMBS		2	Aug 82
DB207	205/1	DMBS		1	Sep 80
DE201	207	DTS	681	3	Nov 84
DE202	204	DTS		4	Nov 84
DE203	210	DTS		3	Aug 82
DE204	205/1	DTS		1	Sep 80
	204				
DE301	205	DTC	679	5	Dec 85
	205/1				
DE302	205	DTC	683	2	Nov 84
DE303	205	DTC	680	1	Sep 80
DH201	201	TS	670	2	Dec 81
	202				
DH202	203	TS	671	2	Nov 84
	205				
DH203	205/1	TS	672	4	Nov 84
	210				
DH205	210	TS		3	Aug 82
DH206	205/1	TS		2	Dec 81
DH301	207	TC	667	2	Nov 84
DH302	210	TC		2	Aug 82
DH303	201	TC	660	1	Jun 81
	201				
DH304	202	TC	661	2	Nov 84
	203				
DH305	206	TC	660	1	Jun 81
GH102		TF	666	7	Mar 87
GH103		TF		2	Mar 87
GH202		TS	675	3	Mar 87
GH203		TS		5	Mar 87
GJ201		TGS	676	3	Mar 87

Design Code	Class	Vehicle Type	ex Diag	Issue	Date
GK101		TRFB	697	2	Mar 87
GK102		TRFM		1	Mar 87
GK202		TRSB	695	4	Mar 87
GK401		TRUB	697	5	Mar 87
GL101		TRFK	696	2	Mar 87
GL402		TRUK	696	3	Mar 87
GM401		TLUK		2	Mar 87
GN401		TRB		2	Mar 87

PREFACE

A complete list of Vehicle Diagram Books is shown below, together with new or revised book reference numbers & the colours of the respective book covers. The existing Diagram books covering Locomotives and Rail Crane vehicles which were previously shown with MT/reference numbers, have now received new covers in accordance with this revised numbering system.

REVISED VEHICLE DIAGRAM BOOK NUMBERS

Vehicle Type	Diagram Book No	Colour of Cover	Vehicle Type	Diagram Book No	Colour of Cover
<u>Locomotives:- Diagram Book Series 100</u>			<u>Freight Vehicles:- Diagram Book Series 300</u>		
Diesel Electric Main Line Locos	100 (Previously No MT/25)	Red	Privately Owned Freight Vehicles	300	White
Electric Main Line Locos	110 (Previously No MT/26)	Green	Privately Owned International Ferry Vehicle	310	White
Diesel Shunting Locos	120 (Previously No MT/27)	Yellow	BR Revenue Freight Vehicle	320	Buff
<u>Coaching & Multiple Unit Stock:- Diagram Book Series 200</u>			BR International Ferry Vehicles	330	Buff
Loco Hauled Coaches	200	Orange	Foreign Administration Freight Vehicles	340	White
Electric Multiple Units	210	Blue	BR Service Department Vehicles	350	Buff
Diesel Multiple Units (Railcar)	220	Pink			
Diesel Electric Multiple Units (HST)	230	Pink			
			<u>ON Track Plant:- Diagram Book Series 400</u>		
			Rail Cranes & Tracklaying Vehicles	400 (Previously No MT/212)	Red

Issued by:-

Director of Mechanical & Electrical Engineering
Railway Technical Centre
DERBY

JULY 1982

Appendix To Vehicle Diagram Book No 230

Diesel Electric Multiple Unit Trains

(Including H.S.T.)

INDEX

OF

DEMU. VEHICLE NUMBERS TO DESIGN CODE

1. The first part of the document is a list of names and addresses.

2. The second part of the document is a list of names and addresses.

3. The third part of the document is a list of names and addresses.

4. The fourth part of the document is a list of names and addresses.

PREF/ OWNER	VEH NO/SFX	DESIGN CODE	PREF/ OWNER	VEH NO/SFX	DESIGN CODE	PREF/ OWNER	VEH NO/SFX	DESIGN CODE	PREF/ OWNER	VEH NO/SFX	DESIGN CODE	PREF/ OWNER	VEH NO/SFX	DESIGN CODE
E	53000	DA201 0A	S	60044	DB202 0A	S	60148	DB204 0A	S	60549	DH202 0A	S	60668	DH203 0A
E	53001	DB206 0A	S	60045	DB202 0A	S	60149	DB204 0A	S	60550	DH202 0A	S	60669	DH203 0A
E	54000	DE203 0A	S	60100	DB203 0A	S	60150	DB204 0A	S	60551	DH202 0A	S	60670	DH203 0A
E	54001	DE203 0A	S	60101	DB203 0A	S	60151	DB204 0A	S	60552	DH202 0A	S	60671	DH203 0A
E	57000	DH205 0A	S	60102	DB203 0A	S	60500	DH201 0A	S	60553	DH202 0A	S	60672	DH203 0A
E	57001	DH205 0A	S	60103	DB203 0A	S	60501	DH201 0A	S	60554	DH202 0A	S	60673	DH203 0A
E	58000	DH302 0A	S	60104	DB203 0A	S	60502	DH201 0A	S	60555	DH202 0A	S	60674	DH203 0A
S	60000	DB201 0C	S	60105	DB203 0A	S	60503	DH201 0A	S	60556	DH202 0A	S	60675	DH203 0A
S	60001	DB201 0C	S	60106	DB203 0A	S	60504	DH201 0A	S	60557	DH202 0A	S	60676	DH203 0A
S	60002	DB201 0A	S	60107	DB203 0A	S	60505	DH201 0A	S	60558	DH202 0A	S	60677	DH203 0A
S	60003	DB201 0B	S	60108	DB203 0A	S	60506	DH201 0A	S	60559	DH202 0A	S	60678	DH203 0A
S	60004	DB201 0A	S	60109	DB203 0A	S	60509	DH201 0A	S	60560	DH202 0A	S	60700	DH303 0A
S	60005	DB201 0A	S	60110	DB203 1C	S	60510	DH201 0A	S	60561	DH202 0A	S	60701	DH303 0A
S	60006	DB201 0A	S	60111	DB203 0A	S	60511	DH201 0A	S	60600	DH301 0A	S	60702	DH305 0A
S	60007	DB201 0A	S	60112	DB203 0A	S	60512	DH201 0A	S	60601	DH301 0A	S	60703	DH303 0A
S	60008	DB201 0C	S	60113	DB203 0A	S	60513	DH201 0A	S	60602	DH301 0A	S	60704	DH303 0A
S	60009	DB201 0C	S	60114	DB203 0A	S	60514	DH201 0A	S	60603	DH301 0A	S	60705	DH303 0A
S	60010	DB201 0C	S	60115	DB203 0A	S	60515	DH201 0A	S	60604	DH301 0A	S	60707	DH304 0A
S	60011	DB201 0C	S	60116	DB203 0A	S	60516	DH201 0A	S	60605	DH301 0A	S	60708	DH304 0A
S	60012	DB201 0C	S	60117	DB203 0A	S	60517	DH201 0A	S	60606	DH301 0A	S	60709	DH304 0A
S	60013	DB201 0C	S	60118	DB203 0A	S	60518	DH201 0A	S	60607	DH301 0A	S	60710	DH304 0A
S	60014	DB202 0A	S	60119	DB203 0A	S	60519	DH201 0A	S	60608	DH301 0A	S	60711	DH304 0A
S	60015	DB202 0A	S	60120	DB203 0A	S	60521	DH202 0A	S	60609	DH301 0A	S	60712	DH304 0A
S	60016	DB202 0A	S	60121	DB203 0A	S	60522	DH202 0A	S	60610	DH301 0A	S	60713	DH304 0A
S	60017	DB202 0A	S	60122	DB203 0A	S	60523	DH202 0A	S	60611	DH301 0A	S	60714	DH304 0A
S	60018	DB202 0A	S	60123	DB203 0A	S	60524	DH202 0A	S	60612	DH301 0A	S	60715	DH304 0A
S	60019	DB202 0A	S	60124	DB203 0A	S	60525	DH202 0A	S	60613	DH301 0A	S	60716	DH304 0A
S	60020	DB202 0A	S	60125	DB203 0A	S	60526	DH202 0A	S	60614	DH301 0A	S	60717	DH304 0A
S	60021	DB202 0A	S	60126	DB205 0A	S	60527	DH202 0A	S	60615	DH301 0A	S	60718	DH304 0A
S	60022	DB202 0A	S	60127	DB205 0A	S	60528	DH202 0A	S	60616	DH301 0A	S	60719	DH304 0A
S	60023	DB202 0A	S	60128	DB205 0A	S	60529	DH202 0A	S	60617	DH301 0A	S	60720	DH304 0A
S	60024	DB202 0A	S	60129	DB205 0A	S	60530	DH202 0A	S	60618	DH301 0A	S	60721	DH304 0A
S	60025	DB202 0A	S	60130	DB205 0A	S	60531	DH202 0A	S	60650	DH203 0A	S	60722	DH304 0A
S	60026	DB202 0A	S	60131	DB205 0A	S	60532	DH202 0A	S	60651	DH203 0A	S	60800	DE301 0A
S	60027	DB202 0A	S	60132	DB205 0A	S	60533	DH202 0A	S	60652	DH203 0A	S	60801	DE301 0A
S	60028	DB202 0A	S	60133	DB205 0A	S	60534	DH202 0A	S	60653	DH203 0A	S	60802	DE301 0A
S	60029	DB202 0A	S	60134	DB205 0A	S	60535	DH202 0A	S	60654	DH203 0A	S	60803	DE301 0A
S	60030	DB202 0A	S	60135	DB205 0A	S	60536	DH202 0A	S	60655	DH203 0A	S	60804	DE301 0A
S	60031	DB202 0A	S	60136	DB205 0A	S	60537	DH202 0A	S	60656	DH203 0A	S	60805	DE302 0A
S	60032	DB202 0A	S	60137	DB205 0A	S	60538	DH202 0A	S	60657	DH203 0A	S	60806	DE302 0A
S	60033	DB202 0A	S	60138	DB205 0A	S	60539	DH202 0A	S	60658	DH203 0A	S	60807	DE301 0A
S	60034	DB202 0A	S	60139	DB205 0A	S	60540	DH202 0A	S	60659	DH203 0A	S	60808	DE302 0A
S	60035	DB202 0A	S	60140	DB205 0A	S	60541	DH202 0A	S	60660	DH203 1B	S	60809	DE301 0A
S	60037	DB202 0A	S	60141	DB205 0A	S	60542	DH202 0A	S	60661	DH203 0A	S	60810	DE301 1B
S	60038	DB202 0A	S	60142	DB205 0A	S	60543	DH202 0A	S	60662	DH203 0A	S	60811	DE302 0A
S	60039	DB202 0A	S	60143	DB205 0A	S	60544	DH202 0A	S	60663	DH203 0A	S	60812	DE302 0A
S	60040	DB202 0A	S	60144	DB205 0A	S	60545	DH202 0A	S	60664	DH203 0A	S	60813	DE302 0A
S	60041	DB202 0A	S	60145	DB204 0A	S	60546	DH202 0A	S	60665	DH203 0A	S	60814	DE302 0A
S	60042	DB202 0A	S	60146	DB204 0A	S	60547	DH202 0A	S	60666	DH203 0A	S	60815	DE302 0A
S	60043	DB202 0A	S	60147	DB204 0A	S	60548	DH202 0A	S	60667	DH203 0A	S	60816	DE302 0A

PREF/ OWNER CODE	VEH NO/SFX	DESIGN CODE
S	60817	DE302 0A
S	60818	DE301 0A
S	60819	DE301 0A
S	60820	DE302 0A
S	60821	DE301 0A
S	60822	DE302 0A
S	60823	DE301 0A
S	60824	DE301 0A
S	60825	DE301 0A
S	60826	DE303 0A
S	60827	DE303 0A
S	60828	DE303 0A
S	60829	DE303 0A
S	60830	DE303 0A
S	60831	DE303 0A
S	60832	DE303 0A
S	60900	DE201 0A
S	60901	DE201 0A
S	60902	DE201 0A
S	60903	DE201 0A
S	60904	DE201 0A
S	60905	DE201 0A
S	60906	DE201 0A
S	60907	DE201 0A
S	60908	DE201 0A
S	60909	DE201 0A
S	60910	DE201 0A
S	60911	DE201 0A
S	60912	DE201 0A
S	60913	DE201 0A
S	60914	DE201 0A
S	60915	DE201 0A
S	60916	DE201 0A
S	60917	DE201 0A
S	60918	DE201 0A
S	77500	DE202 0A
S	77503	DE202 0A
S	77507	DE202 0A
S	77508	DE202 0A
S	77510	DE202 0A

PREF/ OWNER CODE	VEH NO/SFX	DESIGN CODE	PREF/ OWNER CODE	VEH NO/SFX	DESIGN CODE	PREF/ OWNER CODE	VEH NO/SFX	DESIGN CODE	PREF/ OWNER CODE	VEH NO/SFX	DESIGN CODE	PREF/ OWNER CODE	VEH NO/SFX	DESIGN CODE
W	40001	GK202 0A	E	40313	GK401 0A	E	40510	GL402 0A	W	41042	GH102 0A	SC	41092	GH102 0A
W	40002	GK202 0A	E	40314	GK401 0A	E	40511	GL402 0A	W	41043	GH102 0A	SC	41093	GH102 0A
W	40003	GK202 0A	E	40315	GK401 0A	E	40512	GL402 0A	W	41044	GH102 0A	SC	41094	GH102 0A
W	40004	GK202 0B	E	40316	GK401 0A	E	40513	GL402 0A	W	41045	GH102 0A	SC	41095	GH102 0A
W	40005	GK202 0B	E	40317	GK401 0A	E	40514	GL402 0A	W	41046	GH102 0A	SC	41096	GH102 0A
W	40006	GK202 0B	E	40318	GK401 0A	E	40515	GL402 0A	W	41047	GH102 0A	E	41097	GH102 0A
W	40007	GK202 0B	E	40319	GK401 0A	SC	40516	GL402 0A	W	41048	GH102 0A	E	41098	GH102 0A
W	40008	GK202 0B	E	40320	GK401 0A	SC	40517	GL402 0A	W	41049	GH102 0A	E	41099	GH102 0A
W	40009	GK202 0B	E	40321	GK401 0A	SC	40518	GL402 0A	W	41050	GH102 0A	E	41100	GH102 0A
W	40010	GK202 0B	E	40322	GK401 0B	SC	40519	GL402 0A	W	41051	GH102 0A	E	41101	GH102 0A
W	40011	GK202 0B	W	40323	GK401 0B	SC	40520	GL402 0A	W	41052	GH102 0A	E	41102	GH102 0A
W	40012	GK202 0B	W	40324	GK401 0B	W	41003	GH102 0A	W	41053	GH102 0A	E	41103	GH102 0A
W	40013	GK202 0B	W	40325	GK401 0B	W	41004	GH102 0A	W	41054	GH102 0A	E	41104	GH102 0A
W	40014	GK202 0B	W	40326	GK401 0B	W	41005	GH102 0A	W	41055	GH102 0A	E	41105	GH102 0A
W	40015	GK202 0B	W	40327	GK401 0B	W	41006	GH102 0A	W	41056	GH102 0A	E	41106	GH102 0A
W	40016	GK202 0B	W	40328	GK401 0B	W	41007	GH102 0A	W	41057	GH102 0A	E	41107	GH102 0A
W	40017	GK202 0B	W	40329	GK401 0B	W	41008	GH102 0A	E	41058	GH102 0A	E	41108	GH102 0A
W	40018	GK202 0B	W	40330	GK401 0B	W	41009	GH102 0A	E	41059	GH102 0A	E	41109	GH102 0A
E	40019	GK202 0B	W	40331	GK401 0B	W	41010	GH102 0A	E	41060	GH102 0A	E	41110	GH102 0A
E	40020	GK202 0B	W	40332	GK401 0B	W	41011	GH102 0A	E	41061	GH102 0A	E	41111	GH102 0A
E	40021	GK202 0B	W	40333	GK401 0B	W	41012	GH102 0A	E	41062	GH102 0A	E	41112	GH102 0A
E	40022	GK202 0B	W	40334	GK401 0B	W	41013	GH102 0A	E	41063	GH102 0A	E	41113	GH102 0A
E	40023	GK202 0B	W	40335	GK401 0B	W	41014	GH102 0A	E	41064	GH102 0A	E	41114	GH102 0A
E	40024	GK202 0B	W	40336	GK401 0B	W	41015	GH102 0A	E	41065	GH102 0A	E	41115	GH102 0A
E	40025	GK202 0B	W	40337	GK401 0B	W	41016	GH102 0A	E	41066	GH102 0A	E	41116	GH102 0A
E	40026	GK202 0B	W	40338	GK401 0B	W	41017	GH102 0A	E	41067	GH102 0A	E	41117	GH102 0A
E	40027	GK202 0B	E	40339	GK401 0B	W	41018	GH102 0A	E	41068	GH102 0A	E	41118	GH102 0A
E	40028	GK202 0B	E	40340	GK401 0B	W	41019	GH102 0A	E	41069	GH102 0A	E	41119	GH102 0A
E	40029	GK202 0B	E	40341	GK401 0B	W	41020	GH102 0A	E	41070	GH102 0A	E	41120	GH102 0A
E	40030	GK202 0B	E	40342	GK401 0B	W	41021	GH102 0A	E	41071	GH102 0A	W	41121	GH102 0B
E	40031	GK202 0B	E	40343	GK401 0B	W	41022	GH102 0A	E	41072	GH102 0A	W	41122	GH102 0B
E	40032	GK202 0B	W	40344	GK401 0B	W	41023	GH102 0A	E	41073	GH102 0A	W	41123	GH102 0B
SC	40033	GK202 0B	W	40345	GK401 0B	W	41024	GH102 0A	E	41074	GH102 0A	W	41124	GH102 0B
SC	40034	GK202 0B	W	40346	GK401 0B	W	41025	GH102 0A	E	41075	GH102 0A	W	41125	GH102 0B
SC	40035	GK202 0B	W	40347	GK401 0B	W	41026	GH102 0A	E	41076	GH102 0A	W	41126	GH102 0B
SC	40036	GK202 0B	W	40348	GK401 0B	W	41027	GH102 0A	E	41077	GH102 0A	W	41127	GH102 0B
SC	40037	GK202 0B	W	40349	GK401 0B	W	41028	GH102 0A	E	41078	GH102 0A	W	41128	GH102 0B
W	40300	GK401 0A	W	40350	GK401 0B	W	41029	GH102 0A	E	41079	GH102 0A	W	41129	GH102 0B
W	40301	GK401 0A	W	40351	GK401 0B	W	41030	GH102 0A	E	41080	GH102 0A	W	41130	GH102 0B
W	40302	GK401 0A	W	40352	GK401 0B	W	41031	GH102 0A	E	41081	GH102 0A	W	41131	GH102 0B
W	40303	GK401 0A	W	40353	GK401 0B	W	41032	GH102 0A	E	41082	GH102 0A	W	41132	GH102 0B
W	40304	GK401 0A	E	40501	GL402 0A	W	41033	GH102 0A	E	41083	GH102 0A	W	41133	GH102 0B
W	40305	GK401 0A	E	40502	GL402 0A	W	41034	GH102 0A	E	41084	GH102 0A	W	41134	GH102 0B
W	40306	GK401 0A	E	40503	GL402 0A	W	41035	GH102 0A	E	41085	GH102 0A	W	41135	GH102 0B
W	40307	GK401 0A	E	40504	GL402 0A	W	41036	GH102 0A	E	41086	GH102 0A	W	41136	GH102 0B
W	40308	GK401 0A	E	40505	GL402 0A	W	41037	GH102 0A	E	41087	GH102 0A	W	41137	GH102 0B
W	40309	GK401 0A	E	40506	GL402 0A	W	41038	GH102 0A	SC	41088	GH102 0A	W	41138	GH102 0B
E	40310	GK401 0A	E	40507	GL402 0A	W	41039	GH102 0A	SC	41089	GH102 0A	W	41139	GH102 0B
E	40311	GK401 0A	E	40508	GL402 0A	W	41040	GH102 0A	SC	41090	GH102 0A	W	41140	GH102 0B
E	40312	GK401 0A	E	40509	GL402 0A	W	41041	GH102 0A	SC	41091	GH102 0A	W	41141	GH102 0B

PREF/ OWNER	VEH NO/SFX	DESIGN CODE	PREF/ OWNER	VEH NO/SFX	DESIGN CODE	PREF/ OWNER	VEH NO/SFX	DESIGN CODE	PREF/ OWNER	VEH NO/SFX	DESIGN CODE	PREF/ OWNER	VEH NO/SFX	DESIGN CODE
W	41142	GH102 OB	W	42028	GH202 OB	W	42078	GH202 OB	E	42128	GH202 OB	E	42178	GH202 OB
W	41143	GH102 OB	W	42029	GH202 OB	W	42079	GH202 OB	E	42129	GH202 OB	SC	42179	GH202 OB
W	41144	GH102 OB	W	42030	GH202 OB	W	42080	GH202 OB	E	42130	GH202 OB	SC	42180	GH202 OB
W	41145	GH102 OB	W	42031	GH202 OB	W	42081	GH202 OB	E	42131	GH202 OB	SC	42181	GH202 OB
W	41146	GH102 OB	W	42032	GH202 OB	W	42082	GH202 OB	E	42132	GH202 OB	E	42182	GH202 OB
W	41147	GH102 OB	W	42033	GH202 OB	W	42083	GH202 OB	E	42133	GH202 OB	SC	42183	GH202 OB
W	41148	GH102 OB	W	42034	GH202 OB	W	42084	GH202 OB	E	42134	GH202 OB	SC	42184	GH202 OB
W	41149	GH102 OB	W	42035	GH202 OB	W	42085	GH202 OB	E	42135	GH202 OB	SC	42185	GH202 OB
W	41150	GH102 OB	W	42036	GH202 OB	W	42086	GH202 OB	E	42136	GH202 OB	E	42186	GH202 OB
W	41151	GH102 OB	W	42037	GH202 OB	W	42087	GH202 OB	E	42137	GH202 OB	SC	42187	GH202 OB
W	41152	GH102 OB	W	42038	GH202 OB	W	42088	GH202 OB	E	42138	GH202 OB	SC	42188	GH202 OB
W	41153	GH102 OB	W	42039	GH202 OB	W	42089	GH202 OB	E	42139	GH202 OB	SC	42189	GH202 OB
W	41154	GH102 OB	W	42040	GH202 OB	W	42090	GH202 OB	E	42140	GH202 OB	E	42190	GH202 OB
W	41155	GH102 OB	W	42041	GH202 OB	W	42091	GH202 OB	E	42141	GH202 OB	E	42191	GH202 OB
W	41156	GH102 OB	W	42042	GH202 OB	W	42092	GH202 OB	E	42142	GH202 OB	E	42192	GH202 OB
W	41157	GH102 OB	W	42043	GH202 OB	W	42093	GH202 OB	E	42143	GH202 OB	E	42193	GH202 OB
W	41158	GH102 OB	W	42044	GH202 OB	W	42094	GH202 OB	E	42144	GH202 OB	E	42194	GH202 OB
W	41159	GH102 OB	W	42045	GH202 OB	W	42095	GH202 OB	E	42145	GH202 OB	E	42195	GH202 OB
W	41160	GH102 OB	W	42046	GH202 OB	W	42096	GH202 OB	E	42146	GH202 OB	E	42196	GH202 OB
W	41161	GH102 OB	W	42047	GH202 OB	W	42097	GH202 OB	E	42147	GH202 OB	E	42197	GH202 OB
W	41162	GH102 OB	W	42048	GH202 OB	W	42098	GH202 OB	E	42148	GH202 OB	E	42198	GH202 OB
W	41163	GH102 OB	W	42049	GH202 OB	W	42099	GH202 OB	E	42149	GH202 OB	E	42199	GH202 OB
W	41164	GH102 OB	W	42050	GH202 OB	W	42100	GH202 OB	E	42150	GH202 OB	E	42200	GH202 OB
W	41165	GH102 OB	W	42051	GH202 OB	W	42101	GH202 OB	E	42151	GH202 OB	E	42201	GH202 OB
W	41166	GH102 OB	W	42052	GH202 OB	W	42102	GH202 OB	E	42152	GH202 OB	E	42202	GH202 OB
W	42003	GH202 OA	W	42053	GH202 OB	W	42103	GH202 OB	E	42153	GH202 OB	E	42203	GH202 OB
W	42004	GH202 OA	W	42054	GH202 OB	W	42104	GH202 OB	E	42154	GH202 OB	E	42204	GH202 OB
W	42005	GH202 OA	W	42055	GH202 OB	W	42105	GH202 OB	E	42155	GH202 OB	E	42205	GH202 OB
W	42006	GH202 OA	W	42056	GH202 OB	W	42106	GH202 OB	E	42156	GH202 OB	E	42206	GH202 OB
W	42007	GH202 OA	W	42057	GH202 OB	W	42107	GH202 OB	E	42157	GH202 OB	E	42207	GH202 OB
W	42008	GH202 OA	W	42058	GH202 OB	W	42108	GH202 OB	E	42158	GH202 OB	E	42208	GH202 OB
W	42009	GH202 OA	W	42059	GH202 OB	W	42109	GH202 OB	E	42159	GH202 OB	E	42209	GH202 OB
W	42010	GH202 OA	W	42060	GH202 OB	W	42110	GH202 OB	E	42160	GH202 OB	E	42210	GH202 OB
W	42011	GH202 OA	W	42061	GH202 OB	W	42111	GH202 OB	E	42161	GH202 OB	E	42211	GH202 OB
W	42012	GH202 OA	W	42062	GH202 OB	W	42112	GH202 OB	E	42162	GH202 OB	E	42212	GH202 OB
W	42013	GH202 OA	W	42063	GH202 OB	W	42113	GH202 OB	E	42163	GH202 OB	E	42213	GH202 OB
W	42014	GH202 OA	W	42064	GH202 OB	W	42114	GH202 OB	E	42164	GH202 OB	E	42214	GH202 OB
W	42015	GH202 OA	W	42065	GH202 OB	W	42115	GH202 OB	E	42165	GH202 OB	E	42215	GH202 OB
W	42016	GH202 OA	W	42066	GH202 OB	W	42116	GH202 OB	E	42166	GH202 OB	E	42216	GH202 OB
W	42017	GH202 OA	W	42067	GH202 OB	W	42117	GH202 OB	E	42167	GH202 OB	E	42217	GH202 OB
W	42018	GH202 OA	W	42068	GH202 OB	W	42118	GH202 OB	E	42168	GH202 OB	E	42218	GH202 OB
W	42019	GH202 OA	W	42069	GH202 OB	W	42119	GH202 OB	E	42169	GH202 OB	E	42219	GH202 OB
W	42020	GH202 OA	W	42070	GH202 OB	W	42120	GH202 OB	E	42170	GH202 OB	E	42220	GH202 OB
W	42021	GH202 OA	W	42071	GH202 OB	W	42121	GH202 OB	SC	42171	GH202 OB	E	42221	GH202 OB
W	42022	GH202 OA	W	42072	GH202 OB	W	42122	GH202 OB	SC	42172	GH202 OB	E	42222	GH202 OB
W	42023	GH202 OB	W	42073	GH202 OB	W	42123	GH202 OB	SC	42173	GH202 OB	E	42223	GH202 OB
W	42024	GH202 OB	W	42074	GH202 OB	W	42124	GH202 OB	E	42174	GH202 OB	E	42224	GH202 OB
W	42025	GH202 OB	W	42075	GH202 OB	W	42125	GH202 OB	SC	42175	GH202 OB	E	42225	GH202 OB
W	42026	GH202 OB	W	42076	GH202 OB	W	42126	GH202 OB	SC	42176	GH202 OB	E	42226	GH202 OB
W	42027	GH202 OB	W	42077	GH202 OB	W	42127	GH202 OB	SC	42177	GH202 OB	E	42227	GH202 OB

PREF/ OWNER	VEH NO/SFX	DESIGN CODE	PREF/ OWNER	VEH NO/SFX	DESIGN CODE	PREF/ OWNER	VEH NO/SFX	DESIGN CODE	PREF/ OWNER	VEH NO/SFX	DESIGN CODE	PREF/ OWNER	VEH NO/SFX	DESIGN CODE
E	42228	GH202 OB	W	42278	GH202 OC	W	43024	GB502 OA	E	43074	GB502 OA	W	43124	GB502 OA
E	42229	GH202 OB	W	42279	GH202 OC	W	43025	GB502 OA	E	43075	GB502 OA	W	43125	GB502 OA
E	42230	GH202 OB	W	42280	GH202 OC	W	43026	GB502 OA	E	43076	GB502 OA	W	43126	GB502 OA
E	42231	GH202 OB	W	42281	GH202 OC	W	43027	GB502 OA	E	43077	GB502 OA	W	43127	GB502 OA
E	42232	GH202 OB	W	42282	GH202 OC	W	43028	GB502 OA	E	43078	GB502 OA	W	43128	GB502 OA
E	42233	GH202 OB	W	42283	GH202 OC	W	43029	GB502 OA	E	43079	GB502 OA	W	43129	GB502 OA
E	42234	GH202 OB	W	42284	GH202 OC	W	43030	GB502 OA	E	43080	GB502 OA	W	43130	GB502 OA
E	42235	GH202 OB	W	42285	GH202 OC	W	43031	GB502 OA	E	43081	GB502 OA	W	43131	GB502 OA
E	42236	GH202 OB	W	42286	GH202 OC	W	43032	GB502 OA	E	43082	GB502 OA	W	43132	GB502 OA
E	42237	GH202 OB	W	42287	GH202 OC	W	43033	GB502 OA	E	43083	GB502 OA	W	43133	GB502 OA
E	42238	GH202 OB	W	42288	GH202 OC	W	43034	GB502 OA	E	43084	GB502 OA	W	43134	GB502 OA
E	42239	GH202 OB	W	42289	GH202 OC	W	43035	GB502 OA	E	43085	GB502 OA	W	43135	GB502 OA
E	42240	GH202 OB	W	42290	GH202 OC	W	43036	GB502 OA	SC	43086	GB502 OA	W	43136	GB502 OA
E	42241	GH202 OB	W	42291	GH202 OC	W	43037	GB502 OA	SC	43087	GB502 OA	W	43137	GB502 OA
E	42242	GH202 OB	W	42292	GH202 OC	W	43038	GB502 OA	SC	43088	GB502 OA	W	43138	GB502 OA
E	42243	GH202 OB	W	42293	GH202 OC	W	43039	GB502 OA	SC	43089	GB502 OA	W	43139	GB502 OA
E	42244	GH202 OB	W	42294	GH202 OC	W	43040	GB502 OA	SC	43090	GB502 OA	W	43140	GB502 OA
E	42245	GH202 OB	W	42295	GH202 OC	W	43041	GB502 OA	SC	43091	GB502 OA	W	43141	GB502 OA
E	42246	GH202 OB	W	42296	GH202 OC	W	43042	GB502 OA	SC	43092	GB502 OA	W	43142	GB502 OA
E	42247	GH202 OB	W	42297	GH202 OC	W	43043	GB502 OA	SC	43093	GB502 OA	W	43143	GB502 OA
E	42248	GH202 OB	W	42298	GH202 OC	W	43044	GB502 OA	SC	43094	GB502 OA	W	43144	GB502 OA
E	42249	GH202 OB	W	42299	GH202 OC	W	43045	GB502 OA	SC	43095	GB502 OA	W	43145	GB502 OA
E	42250	GH202 OB	W	42300	GH202 OC	W	43046	GB502 OA	E	43096	GB502 OA	W	43146	GB502 OA
W	42251	GH202 OC	W	42301	GH202 OC	W	43047	GB502 OA	E	43097	GB502 OA	W	43147	GB502 OA
W	42252	GH202 OC	W	42302	GH202 OC	W	43048	GB502 OA	E	43098	GB502 OA	W	43148	GB502 OA
W	42253	GH202 OC	W	42303	GH202 OC	W	43049	GB502 OA	E	43099	GB502 OA	W	43149	GB502 OA
W	42254	GH202 OC	W	42304	GH202 OC	W	43050	GB502 OA	E	43100	GB502 OA	W	43150	GB502 OA
W	42255	GH202 OC	W	42305	GH202 OC	W	43051	GB502 OA	E	43101	GB502 OA	W	43151	GB502 OA
W	42256	GH202 OC	W	43002	GB502 OA	W	43052	GB502 OA	E	43102	GB502 OA	W	43152	GB502 OA
W	42257	GH202 OC	W	43003	GB502 OA	W	43053	GB502 OA	E	43103	GB502 OA	E	43153	GB503 OA
W	42258	GH202 OC	W	43004	GB502 OA	W	43054	GB502 OA	E	43104	GB502 OA	E	43154	GB503 OA
W	42259	GH202 OC	W	43005	GB502 OA	W	43055	GB502 OA	E	43105	GB502 OA	E	43155	GB503 OA
W	42260	GH202 OC	W	43006	GB502 OA	W	43056	GB502 OA	E	43106	GB502 OA	E	43156	GB503 OA
W	42261	GH202 OC	W	43007	GB502 OA	W	43057	GB502 OA	E	43107	GB502 OA	W	43157	GB503 OA
W	42262	GH202 OC	W	43008	GB502 OA	W	43058	GB502 OA	E	43108	GB502 OA	W	43158	GB503 OA
W	42263	GH202 OC	W	43009	GB502 OA	W	43059	GB502 OA	E	43109	GB502 OA	W	43159	GB503 OA
W	42264	GH202 OC	W	43010	GB502 OA	W	43060	GB502 OA	E	43110	GB502 OA	W	43160	GB503 OA
W	42265	GH202 OC	W	43011	GB502 OA	W	43061	GB502 OA	E	43111	GB502 OA	W	43161	GB503 OA
W	42266	GH202 OC	W	43012	GB502 OA	W	43062	GB502 OA	E	43112	GB502 OA	W	43162	GB503 OA
W	42267	GH202 OC	W	43013	GB502 OA	W	43063	GB502 OA	E	43113	GB502 OA	W	43163	GB503 OA
W	42268	GH202 OC	W	43014	GB502 OA	W	43064	GB502 OA	E	43114	GB502 OA	W	43164	GB503 OA
W	42269	GH202 OC	W	43015	GB502 OA	W	43065	GB502 OA	E	43115	GB502 OA	W	43165	GB503 OA
W	42270	GH202 OC	W	43016	GB502 OA	W	43066	GB502 OA	E	43116	GB502 OA	W	43166	GB503 OA
W	42271	GH202 OC	W	43017	GB502 OA	W	43067	GB502 OA	E	43117	GB502 OA	W	43167	GB503 OA
W	42272	GH202 OC	W	43018	GB502 OA	W	43068	GB502 OA	E	43118	GB502 OA	W	43168	GB503 OA
W	42273	GH202 OC	W	43019	GB502 OA	W	43069	GB502 OA	E	43119	GB502 OA	W	43169	GB503 OA
W	42274	GH202 OC	W	43020	GB502 OA	W	43070	GB502 OA	W	43120	GB502 OA	W	43170	GB503 OA
W	42275	GH202 OC	W	43021	GB502 OA	W	43071	GB502 OA	W	43121	GB502 OA	W	43171	GB503 OA
W	42276	GH202 OC	W	43022	GB502 OA	W	43072	GB502 OA	E	43122	GB502 OA	W	43172	GB503 OA
W	42277	GH202 OC	W	43023	GB502 OA	W	43073	GB502 OA	E	43123	GB502 OA	W	43173	GB503 OA

PREF/ OWNER CODE	VEH NO/SFX	DESIGN CODE	PREF/ OWNER CODE	VEH NO/SFX	DESIGN CODE	PREF/ OWNER CODE	VEH NO/SFX	DESIGN CODE
W	43174	GB503 0A	W	44033	GJ201 0A	W	44083	GJ201 0A
W	43175	GB503 0A	W	44034	GJ201 0A	W	44084	GJ201 0A
W	43176	GB503 0A	W	44035	GJ201 0A	W	44085	GJ201 0A
W	43177	GB503 0A	W	44036	GJ201 0A	W	44086	GJ201 0A
W	43178	GB503 0A	W	44037	GJ201 0A	W	44087	GJ201 0A
W	43179	GB503 0A	W	44038	GJ201 0A	W	44088	GJ201 0A
W	43180	GB503 0A	W	44039	GJ201 0A	W	44089	GJ201 0A
W	43181	GB503 0A	W	44040	GJ201 0A	W	44090	GJ201 0A
W	43182	GB503 0A	W	44041	GJ201 0A			
W	43183	GB503 0A	W	44042	GJ201 0A			
W	43184	GB503 0A	W	44043	GJ201 0A			
W	43185	GB503 0A	W	44044	GJ201 0A			
W	43186	GB503 0A	W	44045	GJ201 0A			
W	43187	GB503 0A	W	44046	GJ201 0A			
W	43188	GB503 0A	W	44047	GJ201 0A			
W	43189	GB503 0A	W	44048	GJ201 0A			
W	43190	GB503 0A	W	44049	GJ201 0A			
W	44000	GJ201 0A	W	44050	GJ201 0A			
W	44001	GJ201 0A	W	44051	GJ201 0A			
W	44002	GJ201 0A	W	44052	GJ201 0A			
W	44003	GJ201 0A	W	44053	GJ201 0A			
W	44004	GJ201 0A	W	44054	GJ201 0A			
W	44005	GJ201 0A	W	44055	GJ201 0A			
W	44006	GJ201 0A	W	44056	GJ201 0A			
W	44007	GJ201 0A	W	44057	GJ201 0A			
W	44008	GJ201 0A	W	44058	GJ201 0A			
W	44009	GJ201 0A	W	44059	GJ201 0A			
W	44010	GJ201 0A	W	44060	GJ201 0A			
W	44011	GJ201 0A	W	44061	GJ201 0A			
W	44012	GJ201 0A	W	44062	GJ201 0A			
W	44013	GJ201 0A	W	44063	GJ201 0A			
W	44014	GJ201 0A	W	44064	GJ201 0A			
W	44015	GJ201 0A	W	44065	GJ201 0A			
W	44016	GJ201 0A	W	44066	GJ201 0A			
W	44017	GJ201 0A	W	44067	GJ201 0A			
W	44018	GJ201 0A	W	44068	GJ201 0A			
W	44019	GJ201 0A	W	44069	GJ201 0A			
W	44020	GJ201 0A	W	44070	GJ201 0A			
W	44021	GJ201 0A	W	44071	GJ201 0A			
W	44022	GJ201 0A	W	44072	GJ201 0A			
W	44023	GJ201 0A	W	44073	GJ201 0A			
W	44024	GJ201 0A	W	44074	GJ201 0A			
W	44025	GJ201 0A	W	44075	GJ201 0A			
W	44026	GJ201 0A	W	44076	GJ201 0A			
W	44027	GJ201 0A	W	44077	GJ201 0A			
W	44028	GJ201 0A	W	44078	GJ201 0A			
W	44029	GJ201 0A	W	44079	GJ201 0A			
W	44030	GJ201 0A	W	44080	GJ201 0A			
W	44031	GJ201 0A	W	44081	GJ201 0A			
W	44032	GJ201 0A	W	44082	GJ201 0A			

VEHICLE DIAGRAM BOOK NO 230

FOR

Diesel Electric Multiple Unit Trains

(Including H.S.T.)

()

()

SUMMARY OF CONTENTS

NOTE:- The contents of this book are arranged in alphabetical order, according to vehicle DESIGN CODE

DA Driving Motor Second
DB Driving Motor Brake Second
DE Driving Trailer Second
DE Driving Trailer Composite
DH Trailer Second
DH Trailer Composite

GB Driving Motor Brake - HST
GH Trailer First - HST
GH Trailer Second - HST
GJ Trailer Guards Second - HST
GK Trailer Restaurant Second with Buffet - HST
GK Trailer Restaurant Unclassed with Buffet - HST
GL Trailer Restaurant Unclassed with Kitchen - HST

Barrowmore Management Group

Barrowmore Management Group is a leading provider of management services to the construction industry.

Our services include project management, cost management, and contract administration. We have a proven track record of successful projects across the UK.

We are currently seeking experienced project managers to join our team. If you are interested, please contact us at info@barrowmoremg.co.uk.

DRIVING MOTOR SECOND

CLASS 210

DMS

DA 201

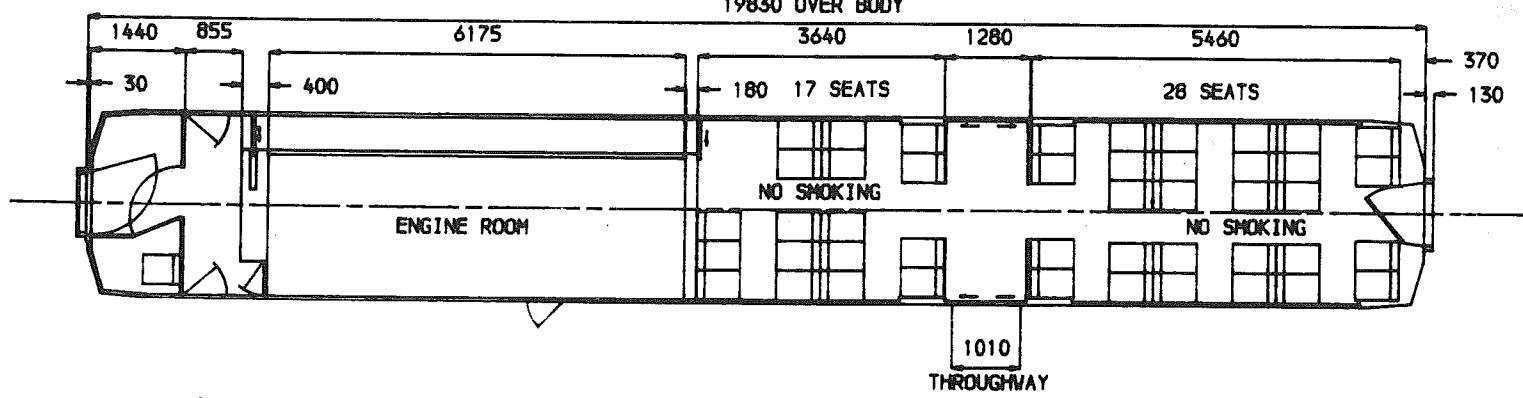
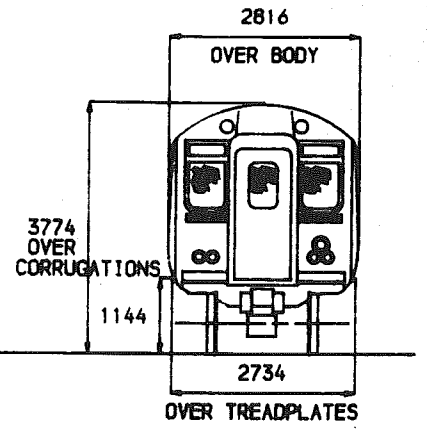
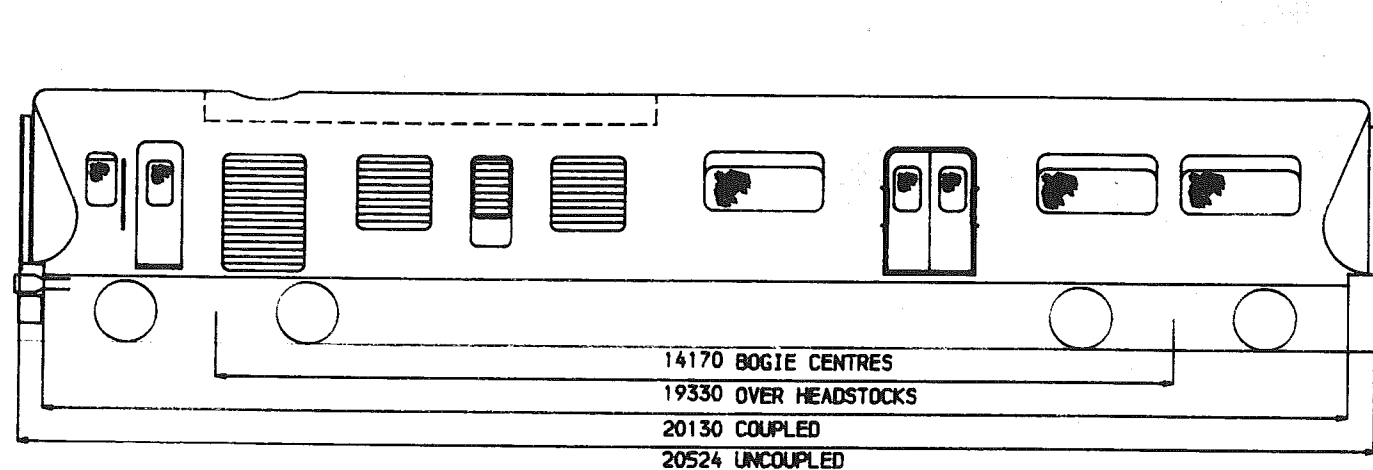

- SEATS 45
- TOILETS -
- COMPARTMENTS -
- GUARDS COMPARTMENTS CAB WHEN TRAILING
- VENTILATION PRESSURE
- CATERING EQUIPMENT -

ISSUE 1 DATE SEP' 80

DA 201

BRAKES
BOGIE/SUSPENSION
BODY CONSTRUCTION
COUPLINGS
TRAIN HEATING
MAX. SPEED M.P.H.
MIN. RAD. CURVE CHAINS
LIGHTING
TARE WEIGHT TONNES
GANGWAYS

A. V. S.
TRAIN COMMUNICATION
BUFFERS

BASIC TYPE

ELECTRO-PNEUMATIC (VESTCODE)
BP 20a & BP 20b (ONE OF EACH)
STEEL
AUTOMATIC TIGHTLOCK OUTER END-BAR INNER END
ELECTRIC (BR) WITH PRESSURE VENTILATION & HEATING
90
3.5
FLUORESCENT & TUNGSTEN
62
CENTRALLY SUPPORTED-SWIVELLING-FLEXIBLE DIAPHRAGM-STEEL FACE PLATE
OUTER END-FLEXIBLE DIAPHRAGM/RIGID (GRP) INNER END
FITTED
DRIVER/GUARD & PUBLIC ADDRESS
NOT FITTED

ALTERNATIVES

TRACTION DATA FOR MULTIPLE UNITS

DEMU-BUILDER	BR DERBY-PROTOTYPE
ENGINE	MTU PT.NO.12V396TC12-12 CYL-V CONFIGURATION-1100 HP
TRACTION MOTORS	4 X 250 HP (187 kW) GEC
ALTERNATOR	GEC TYPE G563AZ-OUTPUT 670 AMPS 1225 VOLTS

BASIC TYPE

DA 201 0A

VARIANTS

NONE

DRIVING MOTOR BRAKE SECOND

CLASS 201

DMBS

DB 201

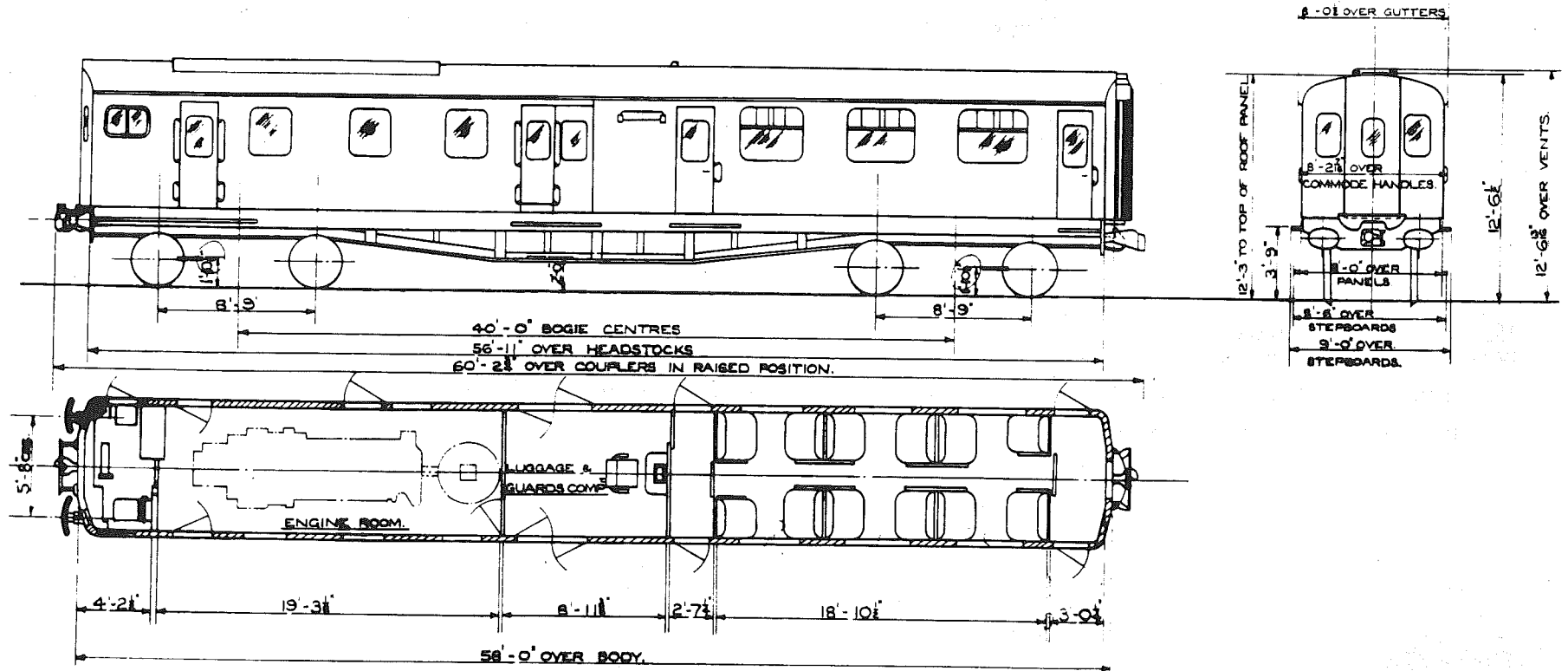

SEATS	22
TOILETS	-
COMPARTMENTS	-
GUARDS COMPARTMENTS	1
VENTILATION	-
CATERING EQUIPMENT	-

ORIGINAL DIAGRAMS FOR REFERENCE, -
BR 650

ISSUE 3 DATE DEC '81

DB 201

BASIC TYPE

ALTERNATIVES

BRAKES
BOGIE/SUSPENSION
BODY CONSTRUCTION
COUPLINGS

ELECTRO-PNEUMATIC
S.R.MK 4 POWERED & UNPOWERED (ONE OF EACH)
STEEL
AUTOMATIC DROPHEAD (BUCKEYE) OUTER END-AUTOMATIC SOLID SHANK
(ALLIANCE NO.2) INNER END
ELECTRIC (BR)
75
3.5
TUNGSTEN
55
EXPRESS ELECTRIC-INNER END ONLY
NOT FITTED
NOT FITTED
RETRACTABLE SPINDLE-559 X 356 OVAL OUTER END ONLY
500 HP

DRIVER/GUARD
600 HP

TRAIN HEATING
MAX. SPEED M.P.H.
MIN. RAD. CURVE CHAINS
LIGHTING
TARE WEIGHT TONNES
GANGWAYS
A. V. S.
TRAIN COMMUNICATION
BUFFERS
ENGINE

TRACTION DATA FOR MULTIPLE UNITS

DEMU-BUILDER	BR EASTLEIGH
ENGINE	ENGLISH ELECTRIC 4 CYL. TYPE 4SRKT MK 11 OF 500 OR 600 HP AT 850 RPM-SEE VARIANTS
TRACTION MOTORS	2-NOSE SUSPENDED-AXLE HUNG
GENERATOR	ENGLISH ELECTRIC TYPE 824

BASIC TYPE

DB 201 0A

VARIANTS

0B 600 HP ENGINE.
0C DRIVER/GUARD COMMUNICATION.

DRIVING MOTOR BRAKE SECOND

CLASS 202
203
206

DMBS

DB 202

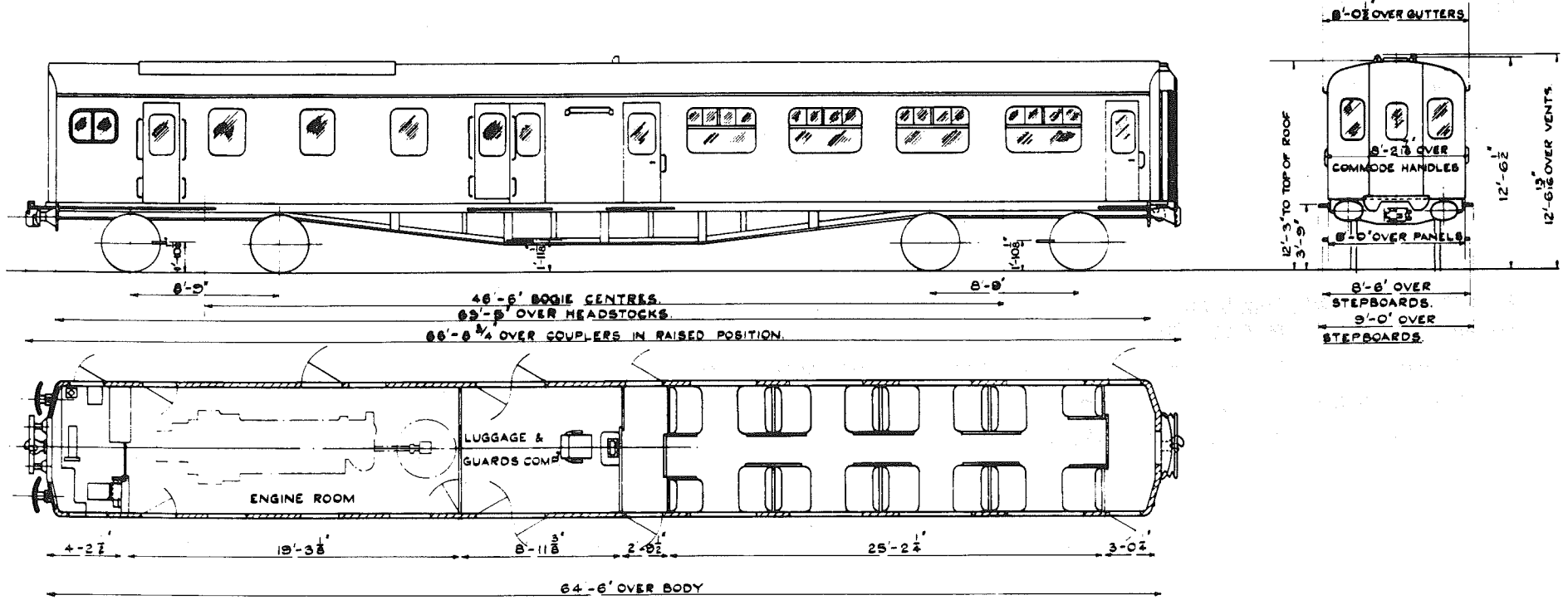

- SEATS 30
- TOILETS -
- COMPARTMENTS -
- GUARDS COMPARTMENTS 1
- VENTILATION -
- CATERING EQUIPMENT -

ORIGINAL DIAGRAMS FOR REFERENCE.-
BR 651

ISSUE 3 DATE DEC' 81

DB 202

BRAKES
BOGIE/SUSPENSION
BODY CONSTRUCTION
COUPLINGS

TRAIN HEATING
MAX. SPEED M.P.H.
MIN. RAD. CURVE CHAINS
LIGHTING
TARE WEIGHT TONNES
GANGWAYS
A.V.S.
TRAIN COMMUNICATION
BUFFERS

BASIC TYPE

ELECTRO-PNEUMATIC
S.R. MK 4 POWERED & UNPOWERED (ONE OF EACH)
STEEL
AUTOMATIC DROPHEAD (BUCKEYE) OUTER END-AUTOMATIC SOLID SHANK
(ALLIANCE NO.2) INNER END
ELECTRIC (BR)
75
3.5
TUNGSTEN
56
EXPRESS ELECTRIC-INNER END ONLY
NOT FITTED
DRIVER/GUARD
RETRACTABLE SPINDLE (559 X 356 OVAL) OUTER END ONLY

ALTERNATIVES

TRACTION DATA FOR MULTIPLE UNITS

DEMU-BUILDER	BR EASTLEIGH
ENGINE	ENGLISH ELECTRIC 4 CYL. TYPE 4SRKT MK 11 OF 500 HP AT 850 RPM
TRACTION MOTORS	2-NOSE SUSPENDED-AXLE HUNG
GENERATOR	ENGLISH ELECTRIC TYPE 824

BASIC TYPE

DB 202 0A

VARIANTS

NONE

DRIVING MOTOR BRAKE SECOND

CLASS 204
205
205/1

DMBS

DB 203

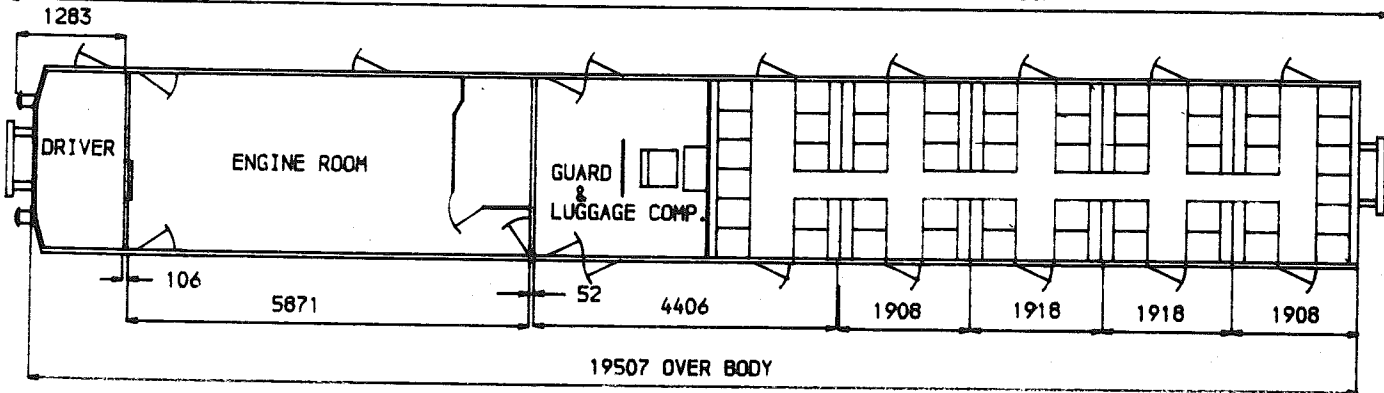
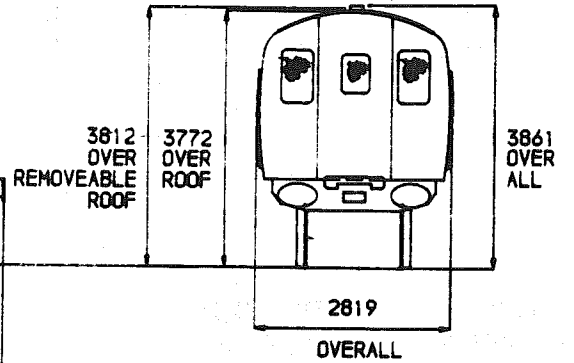
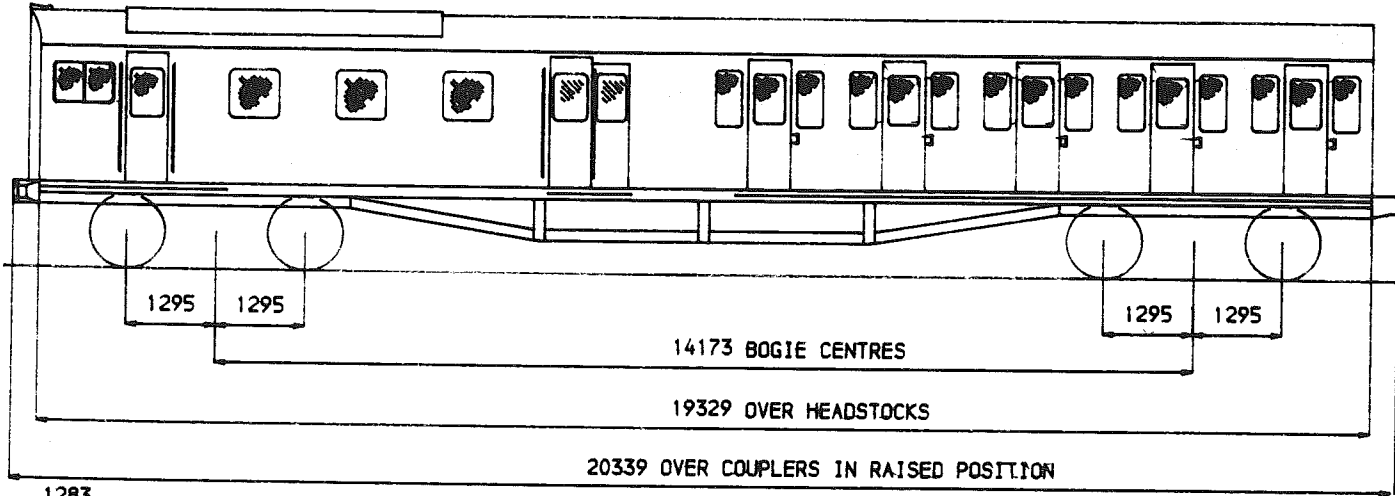

- SEATS 52
- TOILETS -
- COMPARTMENTS -
- GUARDS COMPARTMENTS 1
- VENTILATION -
- CATERING EQUIPMENT -

ORIGINAL DIAGRAMS FOR REFERENCE.-
BR 652

ISSUE 2 DATE DEC '81

DB 203

BASIC TYPE

BRAKES
BOGIE/SUSPENSION
BODY CONSTRUCTION
COUPLINGS

TRAIN HEATING
MAX. SPEED M.P.H.
MIN. RAD. CURVE CHAINS
LIGHTING
TARE WEIGHT TONNES
GANGWAYS
A.V.S.
TRAIN COMMUNICATION
BUFFERS

ELECTRO-PNEUMATIC
S.R. MK 4 POWERED & UNPOWERED (ONE OF EACH)
STEEL
AUTOMATIC DROPHEAD (BUCKEYE) OUTER END-AUTOMATIC SOLID SHANK
(ALLIANCE NO.2) INNER END
ELECTRIC (BR)
75
3.5
ELECTRIC
57
NOT FITTED
FITTED
NOT FITTED
RETRACTABLE SPINDLE-559 X 356 OVAL OUTER END ONLY

ALTERNATIVES

FLUORESCENT & TUNGSTEN

TRACTION DATA FOR MULTIPLE UNITS

DEMU-BUILDER BR EASTLEIGH

ENGINE ENGLISH ELECTRIC 4 CYL. TYPE 4SRKT MK 11 OF 600 HP AT 850 RPM

TRACTION MOTORS 2-NOSE SUSPENDED-AXLE HUNG

GENERATOR ENGLISH ELECTRIC TYPE 824

BASIC TYPE

DB 203 0A

VARIANTS

1C CLASS 205/1-PROTOTYPE REFURBISHED VEHICLE-FLUORESCENT & TUNGSTEN LIGHTING.

DRIVING MOTOR BRAKE SECOND

CLASS 205

DMBS

DB 204

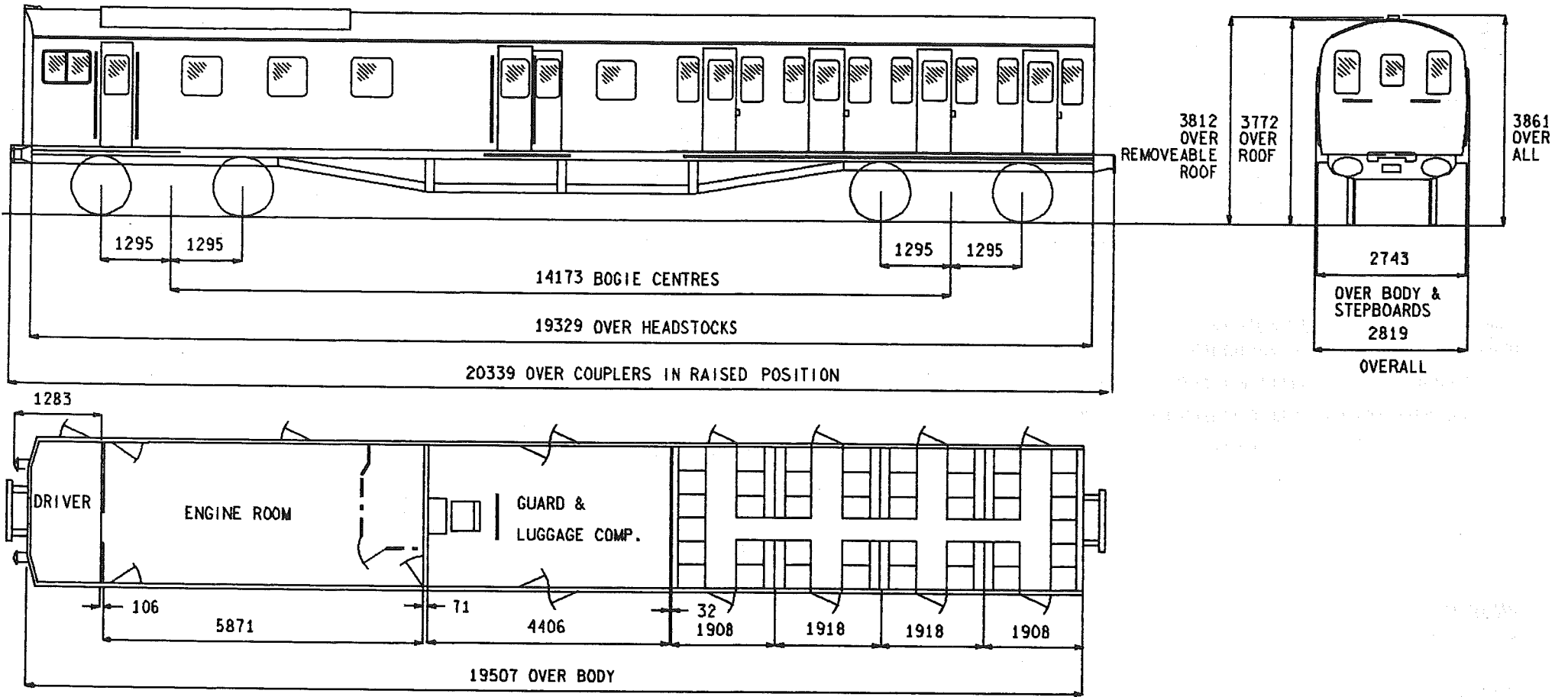

- SEATS 42
- TOILETS -
- COMPARTMENTS -
- GUARDS COMPARTMENTS 1
- VENTILATION -
- CATERING EQUIPMENT -

ORIGINAL DIAGRAMS FOR REFERENCE:
BR 656

ISSUE 3 DATE DEC 85

DB 204

BRAKES
BOGIE/SUSPENSION
BODY CONSTRUCTION
COUPLINGS

TRAIN HEATING
MAX.SPEED M.P.H.
MIN.RAD.CURVE CHAINS
LIGHTING
TARE WEIGHT TONNES
GANGWAYS
A.W.S.
TRAIN COMMUNICATION
BUFFERS

BASIC TYPE

ELECTRO-PNEUMATIC
S.R.MK 4 POWERED & UNPOWERED(ONE OF EACH)
STEEL
AUTOMATIC DROPHEAD(BUCKEYE) OUTER END-AUTOMATIC SOLID SHANK
(ALLIANCE NO.2) INNER END
ELECTRIC(BR)
75
3.5
TUNGSTEN
32.5
NOT FITTED
FITTED
NOT FITTED
RETRACTABLE SPINDLE-559 X 356 OVAL OUTER END ONLY

ALTERNATIVES

TRACTION DATA FOR MULTIPLE UNITS

DEMU-BUILDER BR EASTLEIGH
ENGINE ENGLISH ELECTRIC 4 CYL.TYPE 4SRKT MK 11 OF 600 HP AT 850 RPM
TRACTION MOTORS 2-NOSE SUSPENDED-AXLE HUNG
GENERATOR ENGLISH ELECTRIC TYPE 824

BASIC TYPE

DB 204 QA

VARIANTS

NONE

DRIVING MOTOR BRAKE SECOND

CLASS 207

DMBS

DB 205

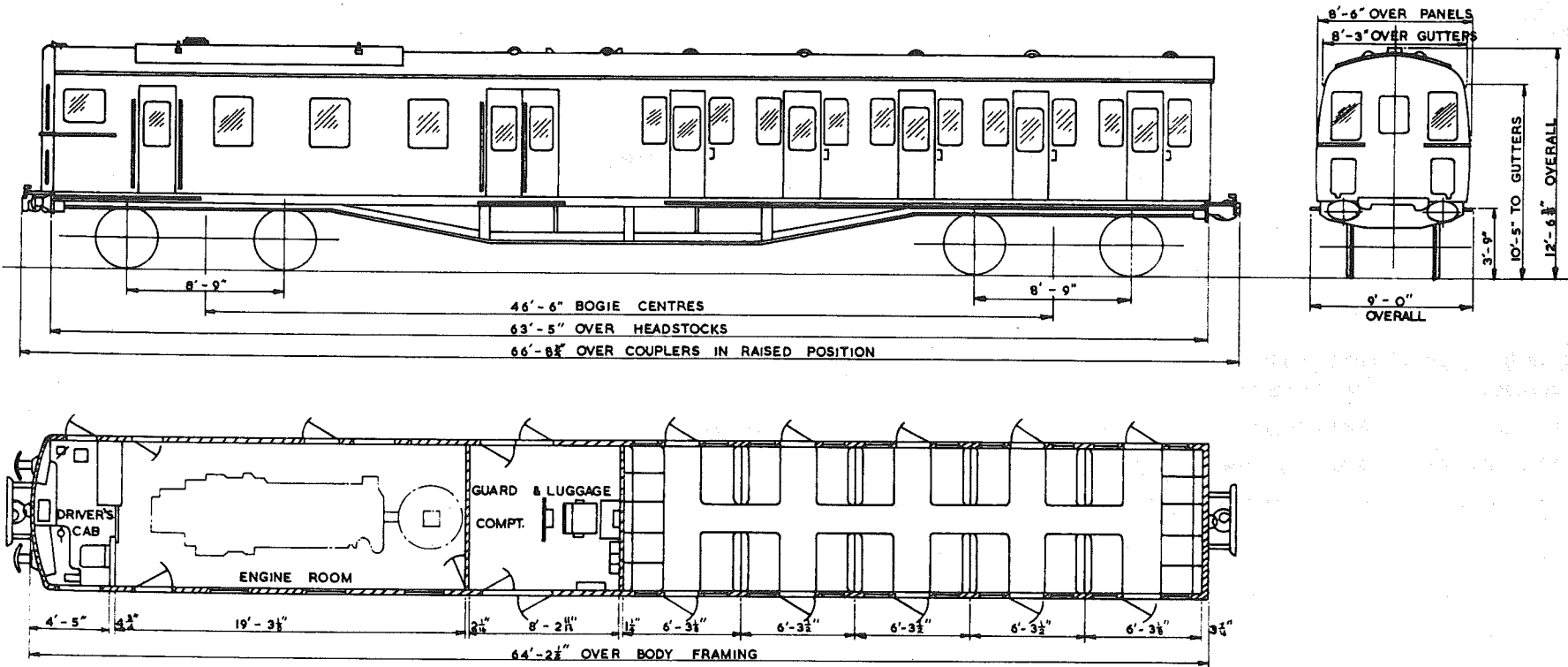

SEATS	42
TOILETS	-
COMPARTMENTS	-
GUARDS COMPARTMENTS	1
VENTILATION	-
CATERING EQUIPMENT	-

ORIGINAL DIAGRAMS FOR REFERENCE.-
BR 655

ISSUE 1 DATE SEP' 80

DB 205

BRAKES
BOGIE/SUSPENSION
BODY CONSTRUCTION
COUPLINGS

TRAIN HEATING
MAX. SPEED M.P.H.
MIN. RAD. CURVE CHAINS
LIGHTING
TARE WEIGHT TONNES
GANGWAYS
A.V.S.
TRAIN COMMUNICATION
BUFFERS

BASIC TYPE

ELECTRO-PNEUMATIC
S.R. MK 3A POWERED & UNPOWERED (ONE OF EACH)
STEEL
AUTOMATIC DROPHEAD (BUCKEYE) OUTER END-AUTOMATIC SOLID SHANK
(ALLIANCE NO.2) INNER END
ELECTRIC (BR)
75
3.5
ELECTRIC
57
NOT FITTED
FITTED
NOT FITTED
RETRACTABLE SPINDLE-559 X 356 OVAL OUTER END ONLY

ALTERNATIVES

TRACTION DATA FOR MULTIPLE UNITS

DEMU-BUILDER	BR EASTLEIGH
ENGINE	ENGLISH ELECTRIC 4 CYL. TYPE 4SRKT MK 11 OF 600 HP AT 850 RPM
TRACTION MOTORS	2-NOSE SUSPENDED-AXLE HUNG
GENERATOR	ENGLISH ELECTRIC TYPE 824

BASIC TYPE

DB 205 0A

VARIANTS

NONE

DRIVING MOTOR BRAKE SECOND

CLASS 210

DMBS

DB 206

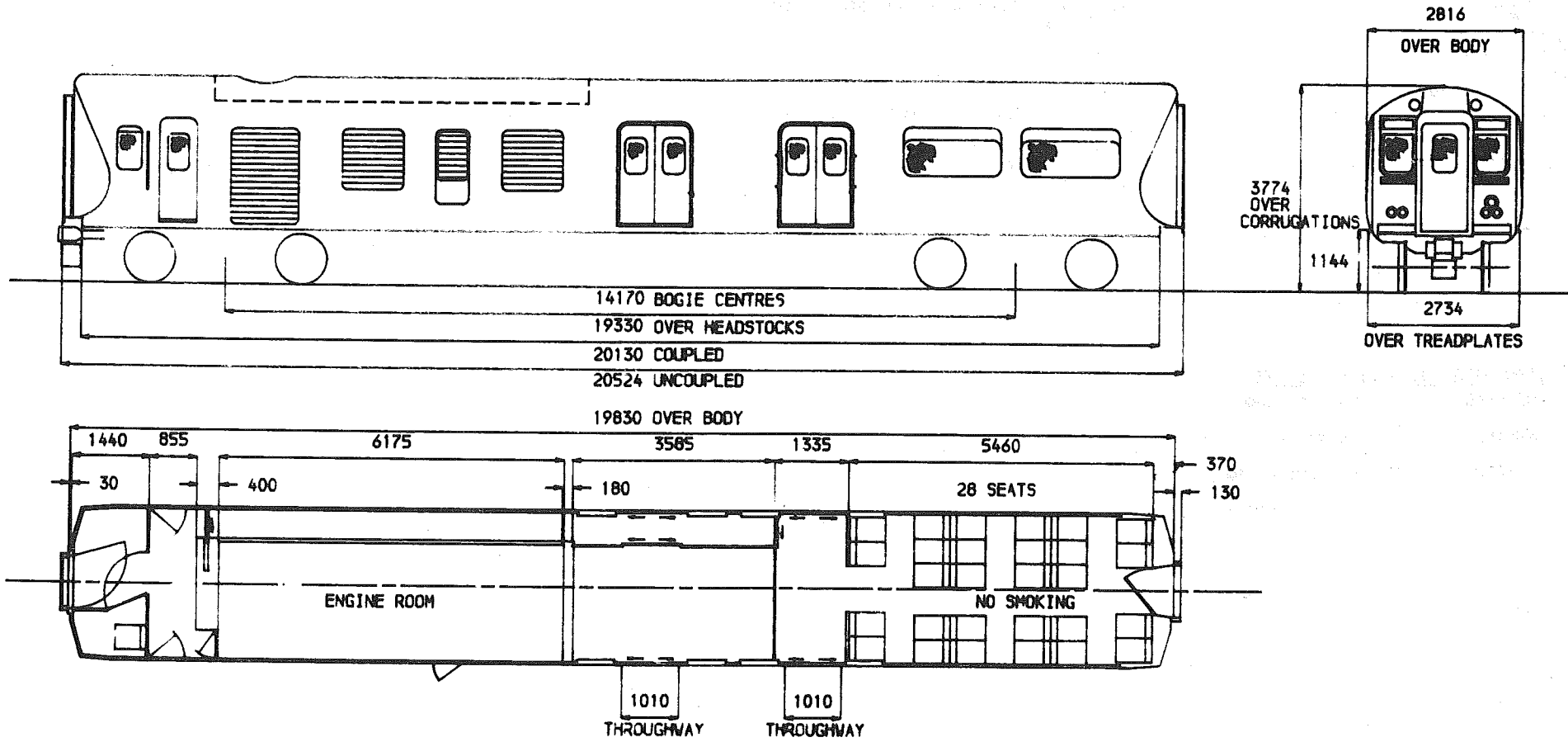

SEATS	28
TOILETS	-
COMPARTMENTS	-
GUARDS COMPARTMENTS	-
VENTILATION	CAB WHEN TRAILING
CATERING EQUIPMENT	PRESSURE
	-

ISSUE 2 DATE AUG '82

BRAKES
BOGIE/SUSPENSION
BODY CONSTRUCTION
COUPLINGS
TRAIN HEATING
MAX. SPEED M.P.H.
MIN. RAD. CURVE CHAINS
LIGHTING
TARE WEIGHT TONNES
GANGWAYS

A.V.S.
TRAIN COMMUNICATION
BUFFERS

BASIC TYPE

ELECTRO-PNEUMATIC (WESTCODE)
BP20a & BP20b (ONE OF EACH)
STEEL
AUTOMATIC TIGHTLOCK OUTER END-BAR INNER END
ELECTRIC (BR) WITH PRESSURE VENTILATION & HEATING
90
3.5
FLUORFSCENT & TUNGSTEN
62
CENTRALLY SUPPORTED-SWIVELLING-FLEXIBLE DIAPHRAGM-STEEL FACE PLATE
OUTER END-FLEXIBLE DIAPHRAGM/RIGID (GRP) INNER END
FITTED
DRIVER/GUARD & PUBLIC ADDRESS
NOT FITTED

ALTERNATIVES

TRACTION DATA FOR MULTIPLE UNITS

DEMU-BUILDER BR DERBY-PROTOTYPE
ENGINE PAXMAN PT. NO. 6RP200-6 CYL. IN LINE-1100 HP
TRACTION MOTORS 4 X 250 HP BRUSH
ALTERNATOR BRUSH BA1002A-OUTPUT 670 AMPS 1240 VOLTS

BASIC TYPE

DB 206 0A

VARIANTS

NONE

DRIVING MOTOR BRAKE SECOND

CLASS 205/1

DMBS

DB 207

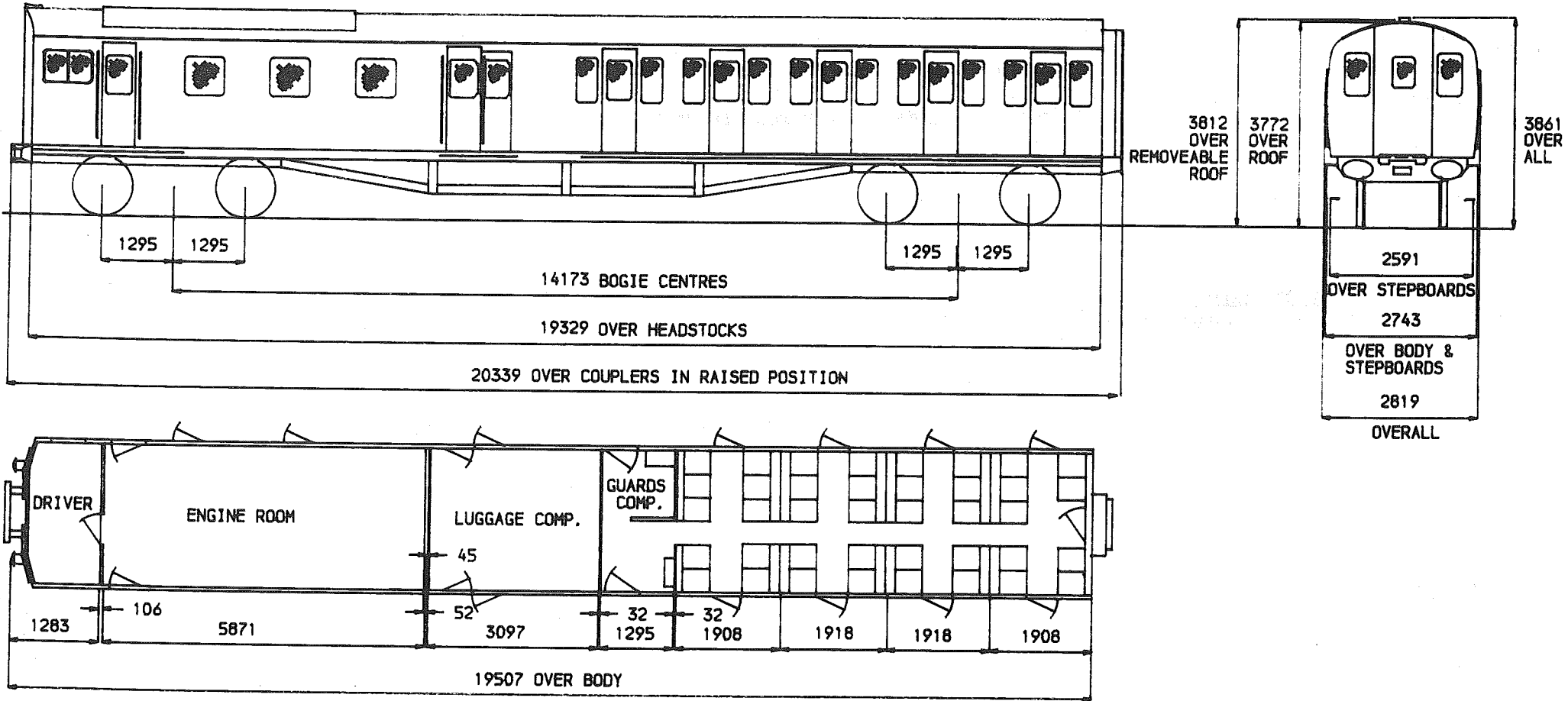

SEATS	. 39
TOILETS	-
COMPARTMENTS	-
GUARDS COMPARTMENTS	1
VENTILATION	-
CATERING EQUIPMENT	-

ISSUE 1 DATE SEP' 80

DB 207

BASIC TYPE

BRAKES
BOGIE/SUSPENSION
BODY CONSTRUCTION
COUPLINGS

TRAIN HEATING
MAX. SPEED M.P.H.
MIN. RAD. CURVE CHAINS
LIGHTING
TARE WEIGHT TONNES
GANGWAYS
A.V.S.
TRAIN COMMUNICATION
BUFFERS

ELECTRO-PNEUMATIC
S.R.MK 4 POWERED & UNPOWERED (ONE OF EACH)
STEEL
AUTOMATIC DROPHEAD (BUCKEYE) OUTER END-AUTOMATIC SOLID SHANK
(ALLIANCE NO.2) INNER END
ELECTRIC (BR)
75
3.5
FLUORESCENT & TUNGSTEN
57
PULLMAN WITH RIGID (GRP) INNER PANELS-INNER END ONLY
FITTED
NOT FITTED
RETRACTABLE SPINDLE (559X356 OVAL) OUTER END ONLY

ALTERNATIVES

TRACTION DATA FOR MULTIPLE UNITS

DEMU-BUILDER BR EASTLIEGH - REFURBISHED 1980 (PROTOTYPE)

BASIC TYPE

DB 207 0A

VARIANTS

NONE

DRIVING TRAILER SECOND

CLASS 207

DTS

DE 201

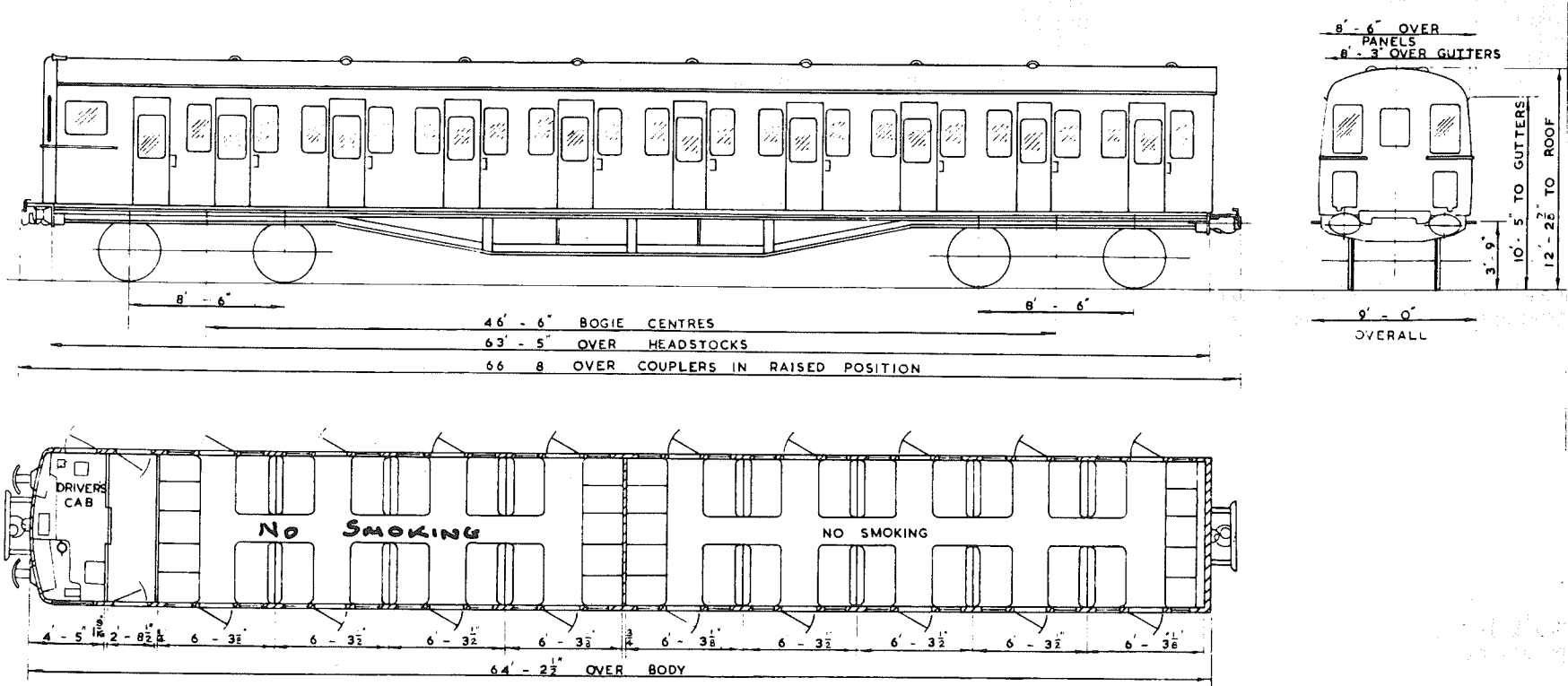

SEATS	76
TOILETS	-
COMPARTMENTS	-
GUARDS COMPARTMENTS	-
VENTILATION	-
CATERING EQUIPMENT	-

ORIGINAL DIAGRAMS FOR REFERENCE:-
BR 681

ISSUE 3 DATE NOV '84

DE 201

BRAKES
BOGIE/SUSPENSION
BODY CONSTRUCTION
COUPLINGS

TRAIN HEATING
MAX. SPEED M.P.H.
MIN. RAD. CURVE CHAINS
LIGHTING
TARE WEIGHT TONNES
GANGWAYS
A.W.S.
TRAIN COMMUNICATION
BUFFERS

BASIC TYPE

ELECTRO-PNEUMATIC
S.R. MK 3A UNPOWERED
STEEL
AUTOMATIC DROPHEAD (BUCKEYE) OUTER END-AUTOMATIC SOLID SHANK
(ALLIANCE NO.2) INNER END
ELECTRIC (BR)
75
3.5
TUNGSTEN
31.5
NOT FITTED
FITTED
NOT FITTED
RETRACTABLE SPINDLE-559 X 356 OVAL OUTER END ONLY

ALTERNATIVES

TRACTION DATA FOR MULTIPLE UNITS

DEMU-BUILDER BR EASTLEIGH

BASIC TYPE

DE 201 0A

VARIANTS

NONE

DRIVING TRAILER SECOND (LUGGAGE)

CLASS 204

DTS

DE 202

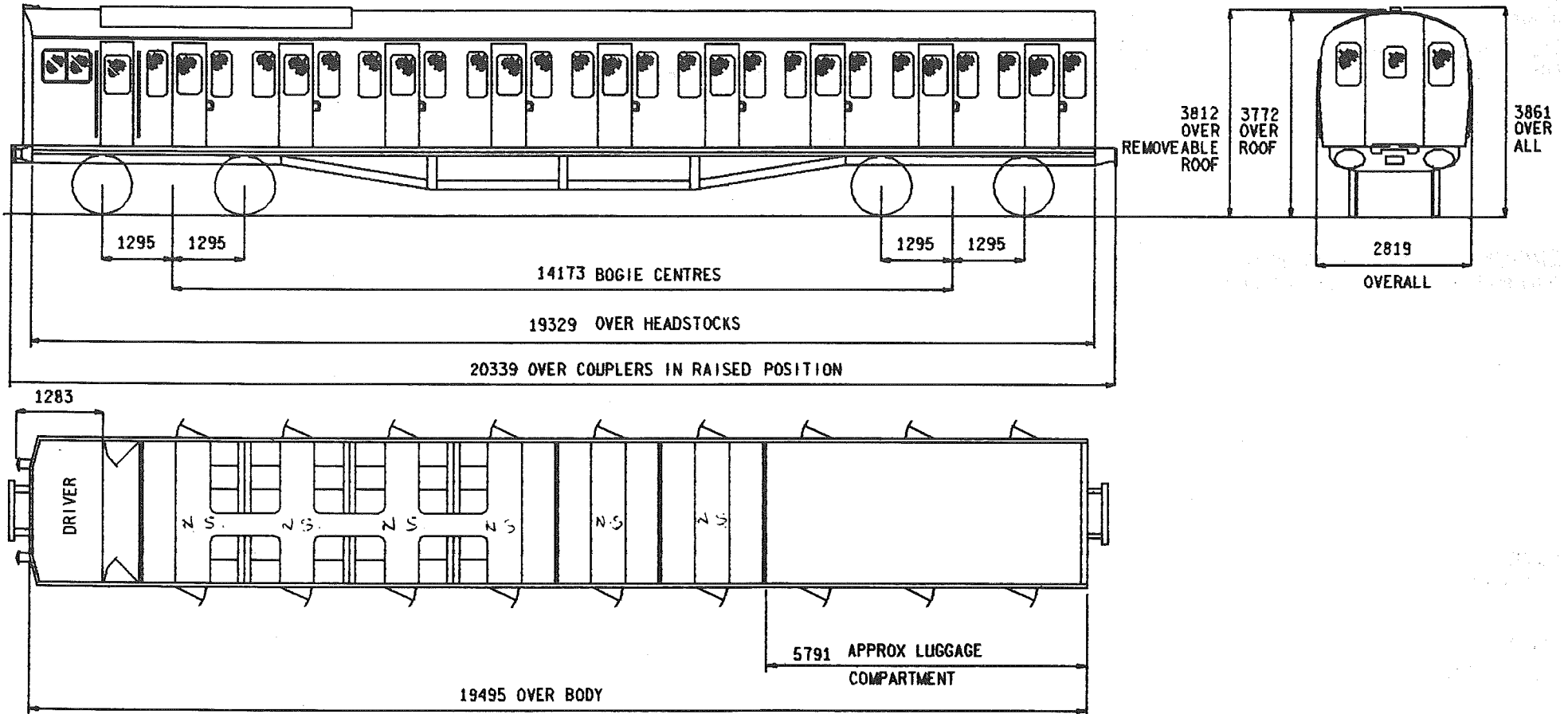

- | | |
|----------------------|---------------|
| SEATS | 66 |
| TOILETS | - |
| COMPARTMENTS | 2 PLUS SALOON |
| LUGGAGE COMPARTMENTS | 1 |
| VENTILATION | - |
| CATERING EQUIPMENT | - |

ISSUE 4 DATE NOV 84

DE 202

BASIC TYPE

ALTERNATIVES

BRAKES
BOGIE/SUSPENSION
BODY CONSTRUCTION
COUPLINGS

ELECTRO-PNEUMATIC
S.R.MK 4 UNPOWERED
STEEL
AUTOMATIC DROPHEAD(BUCKEYE) OUTER END-AUTOMATIC SOLID SHANK
(ALLIANCE NO.2) INNER END
ELECTRIC(BR)
75
3.5
TUNGSTEN
30
NOT FITTED
NOT FITTED
NOT FITTED
RETRACTABLE SPINDLE-559 X 356 OVAL OUTER END ONLY

TRAIN HEATING
MAX.SPEED M.P.H.
MIN.RAD.CURVE CHAINS
LIGHTING
TARE WEIGHT TONNES
GANGWAYS
A.W.S.
TRAIN COMMUNICATION
BUFFERS

TRACTION DATA FOR MULTIPLE UNITS

DEM-J-BUILDER BR EASTLEIGH

BASIC TYPE

DE 202 0A

VARIANTS

NONE

DRIVING TRAILER SECOND

CLASS 210

DTS

DE 203

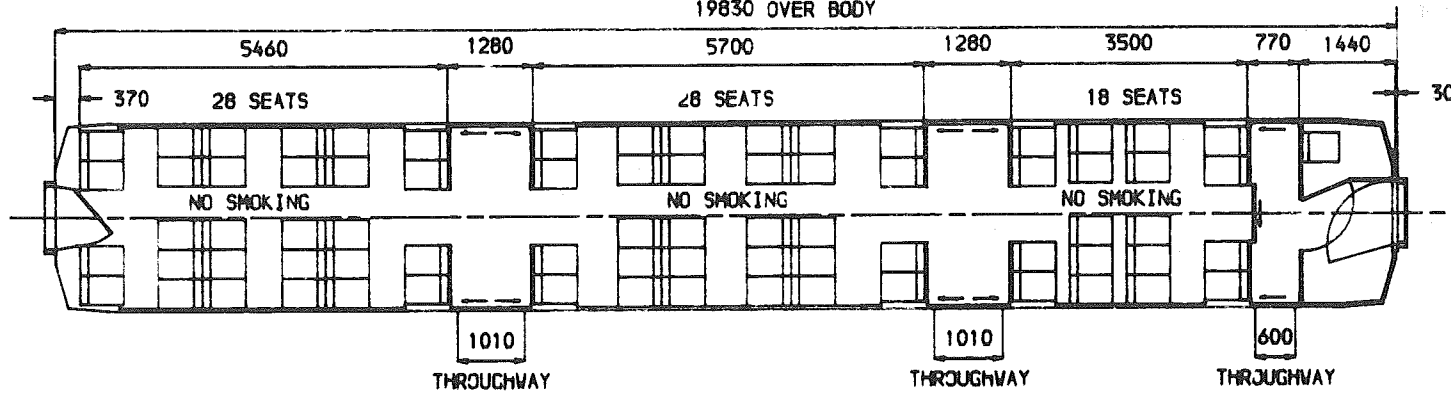
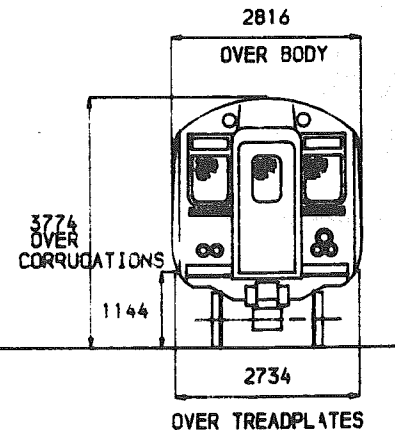
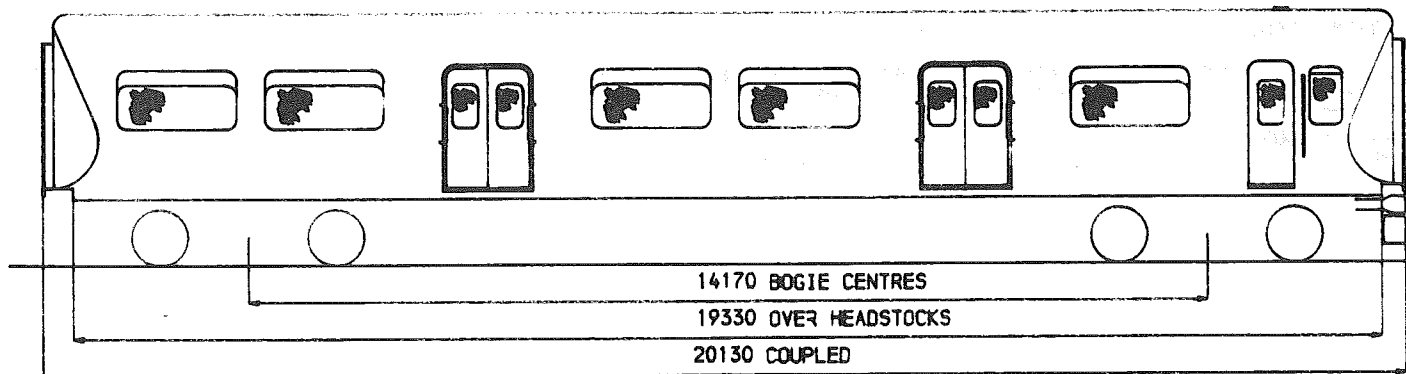

- SEATS 74
- TOILETS -
- COMPARTMENTS -
- GUARDS COMPARTMENTS -
- VENTILATION CAB WHEN TRAILING
- CATERING EQUIPMENT PRESSURE

ISSUE 3 DATE AUG '82

BRAKES
BOGIE/SUSPENSION
BODY CONSTRUCTION
COUPLINGS
TRAIN HEATING
MAX. SPEED M.P.H.
MIN. RAD. CURVE CHAINS
LIGHTING
TARE WEIGHT TONNES
GANGWAYS

A.V.S.
TRAIN COMMUNICATION
BUFFERS

BASIC TYPE

ELECTRO-PNEUMATIC (WESTCODE)
BT13a & BT13b (ONE OF EACH)
STEEL
AUTOMATIC TIGHTLOCK OUTER END-BAR INNER END
ELECTRIC (BR) WITH PRESSURE VENTILATION & HEATING
90
3.5
FLUORESCENT
29
CENTRALLY SUPPORTED-SWIVELLING-FLEXIBLE DIAPHRAGM-STEEL FACE PLATE
OUTER END-FLEXIBLE DIAPHRAGM/RIGID (GRP) INNER END
FITTED
PUBLIC ADDRESS
NOT FITTED

ALTERNATIVES

TRACTION DATA FOR MULTIPLE UNITS

DEMU-BUILDER BR DERBY-PROTOTYPE

BASIC TYPE

DE 203 0A

VARIANTS

NONE

DRIVING TRAILER SECOND

CLASS 205/1

DTS

DE 204

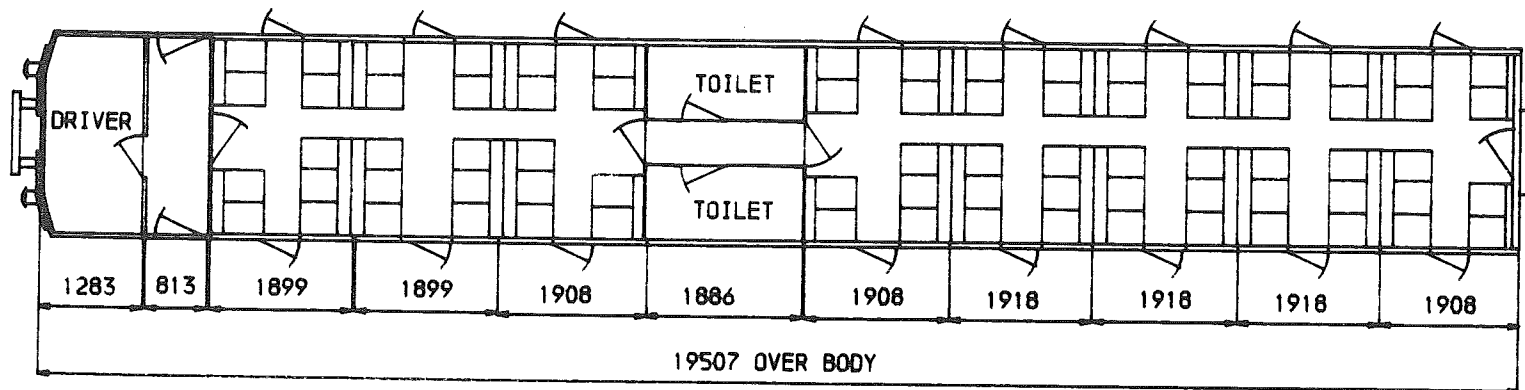
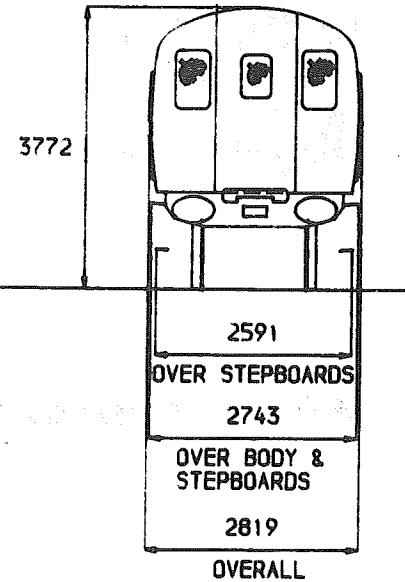
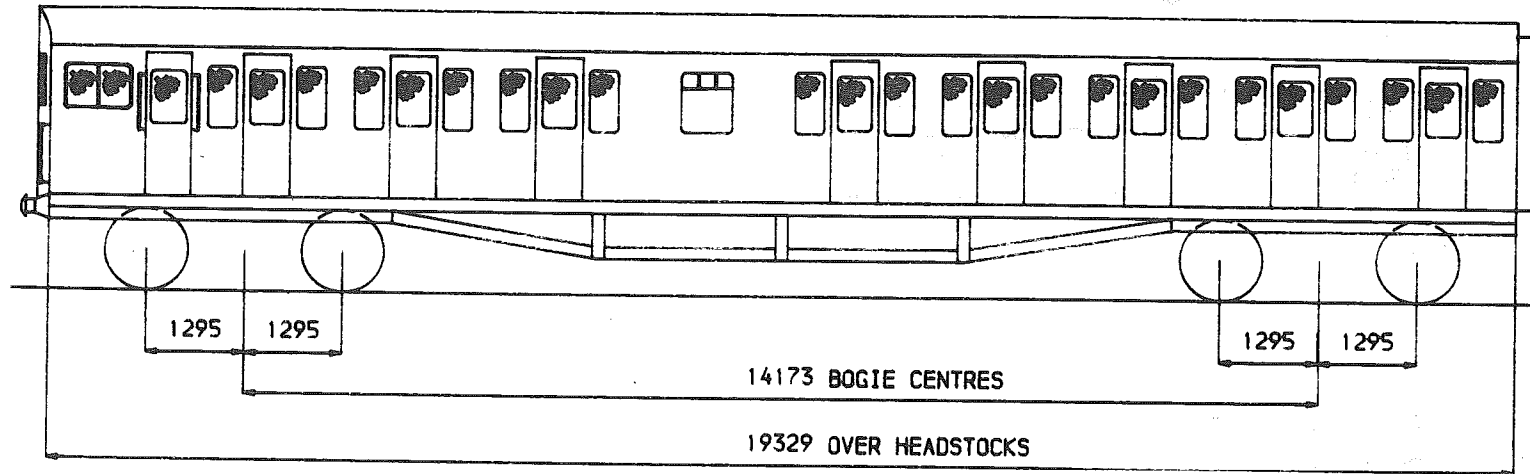

SEATS	76
TOILETS	2
COMPARTMENTS	-
GUARDS COMPARTMENTS	-
VENTILATION	-
CATERING EQUIPMENT	-

ISSUE 1 DATE SEP' 80

DE 204

BRAKES
BOGIE/SUSPENSION
BODY CONSTRUCTION
COUPLINGS

TRAIN HEATING
MAX. SPEED M.P.H.
MIN. RAD. CURVE CHAINS
LIGHTING
TARE WEIGHT TONNES
GANGWAYS
A. V. S.
TRAIN COMMUNICATION
BUFFERS

BASIC TYPE

ELECTRO-PNEUMATIC
S.R. MK 4 UNPOWERED
STEEL
AUTOMATIC DROPHEAD (BUCKEYE) OUTER END-AUTOMATIC SOLID SHANK
(ALLIANCE NO.2) INNER END
ELECTRIC (BR)
75
3.5
FLUORESCENT & TUNGSTEN
32.5
PULLMAN WITH RIGID (GRP) INNER PANELS-INNER END ONLY
FITTED
NOT FITTED
RETRACTABLE SPINDLE (559X356 OVAL) OUTER END ONLY

ALTERNATIVES

TRACTION DATA FOR MULTIPLE UNITS

DEMU-BUILDER BR EASTLIEGH - REFURBISHED 1980 (PROTOTYPE)

BASIC TYPE

DE 204 0A

VARIANTS

NONE

DRIVING TRAILER COMPOSITE

CLASS 204
205
205/1

DTC

DE 301

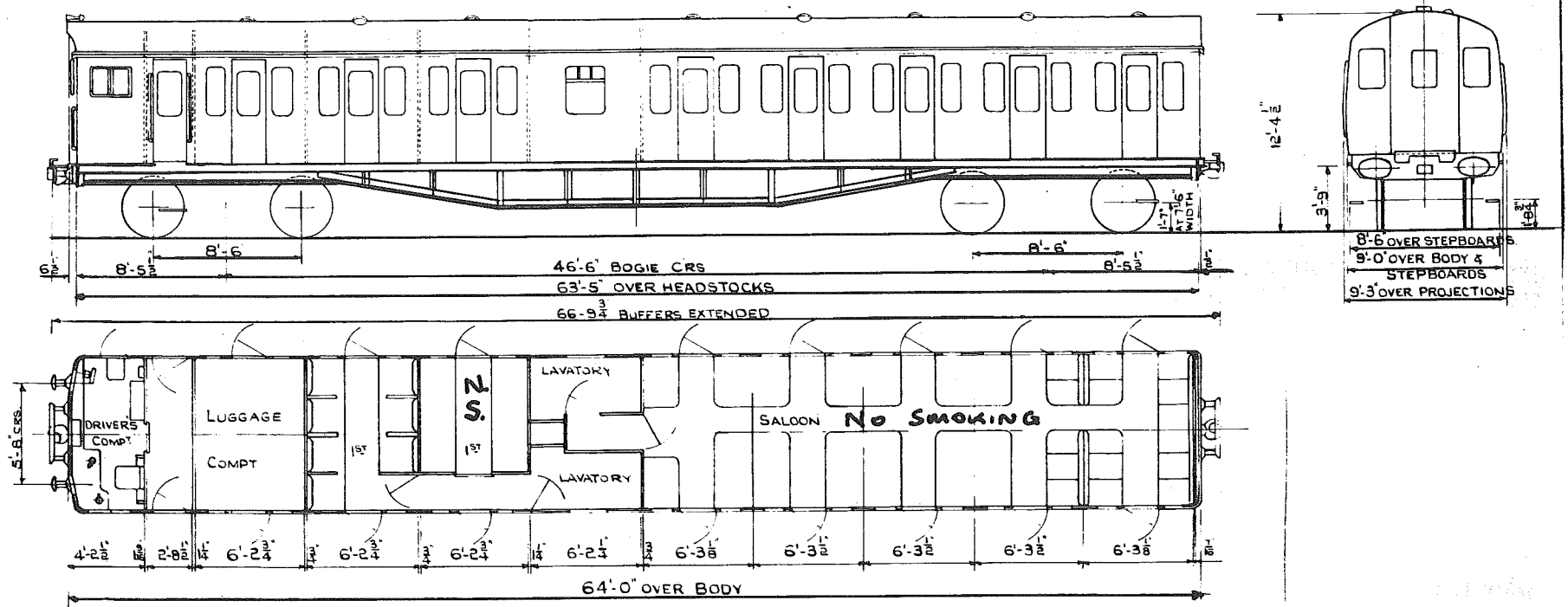

- | | |
|---------------------|--|
| SEATS | 13 FIRST CLASS 50 SECOND CLASS |
| TOILETS | 2 |
| COMPARTMENTS | 2 FIRST CLASS PLUS SECOND CLASS SALOON |
| GUARDS COMPARTMENTS | - |
| VENTILATION | - |
| CATERING EQUIPMENT | - |

ORIGINAL DIAGRAMS FOR REFERENCE:-
BR 679

ISSUE 5 DATE DEC 85

DE 301

BASIC TYPE

ALTERNATIVES

BRAKES
BOGIE/SUSPENSION
BODY CONSTRUCTION
COUPLINGS

ELECTRO PNEUMATIC
S.R.MK 4 UNPOWERED
STEEL
AUTOMATIC DROPHEAD(BUCKEYE) OUTER END-AUTOMATIC SOLID SHANK
(ALLIANCE NO 2) INNER END
ELECTRIC(BR)
75
3.5
TUNGSTEN
32.5
NOT FITTED
FITTED
NOT FITTED
RETRACTABLE SPINDLE(559 X 356 OVAL) OUTER END ONLY

TRAIN HEATING
MAX.SPEED M.P.H.
MIN.RAD.CURVE CHAINS
LIGHTING
TARE WEIGHT TONNES
GANGWAYS
A.W.S.
TRAIN COMMUNICATION
BUFFERS

TRACTION DATA FOR MULTIPLE UNITS

DEMU-BUILDER BR EASTLEIGH

BASIC TYPE

DE 301 0A

VARIANTS

NONE

DRIVING TRAILER COMPOSITE

CLASS 205

DTC

DE 302

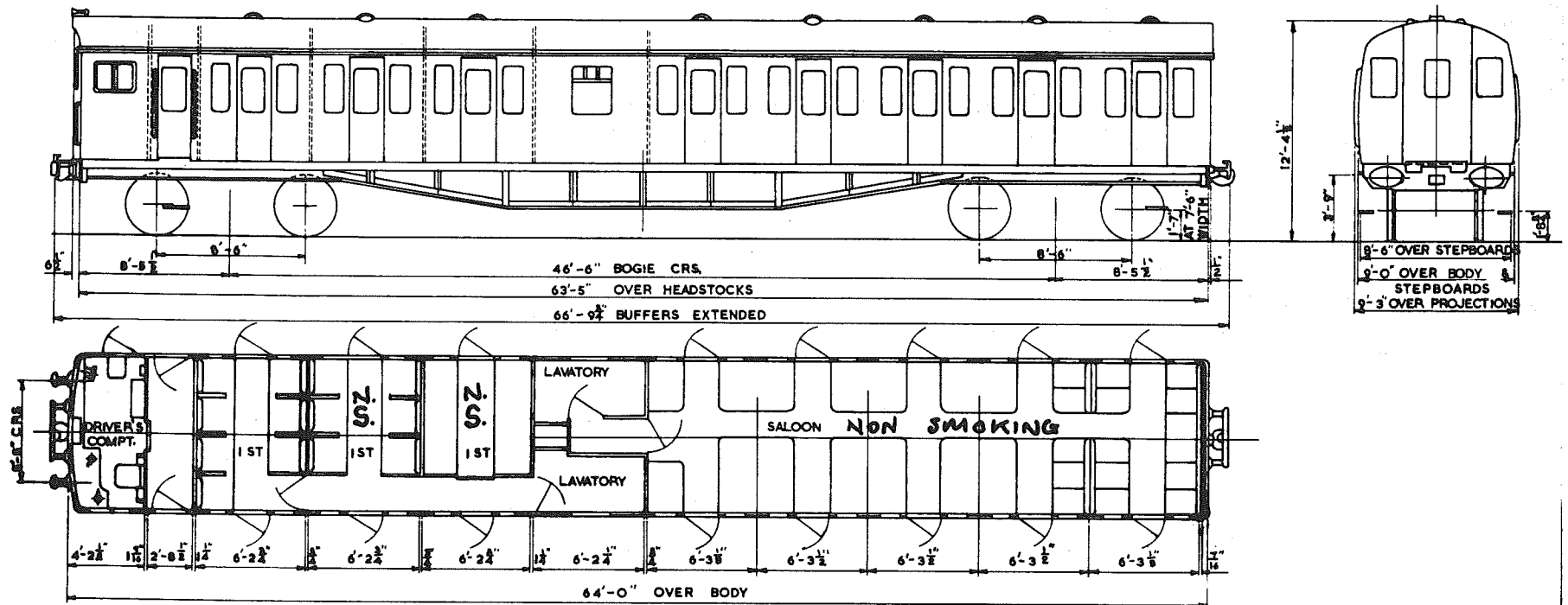

- | | |
|---------------------|--|
| SEATS | 19 FIRST CLASS 50 SECOND CLASS |
| TOILETS | 2 |
| COMPARTMENTS | 3 FIRST CLASS PLUS SECOND CLASS SALOON |
| GUARDS COMPARTMENTS | - |
| VENTILATION | - |
| CATERING EQUIPMENT | - |

ORIGINAL DIAGRAMS FOR REFERENCE - BR 683

ISSUE 2 DATE NOV '84

DE 302

BASIC TYPE

ELECTRO-PNEUMATIC
S.R.MK 4 UNPOWERED
STEEL
AUTOMATIC DROPHEAD(BUCKEYE) OUTER END-AUTOMATIC SOLID SHANK
(ALLIANCE NO.2) INNER END
ELECTRIC(BR)
75
3.5
TUNGSTEN
32.5
NOT FITTED
FITTED
NOT FITTED
RETRACTABLE SPINDLE-559 X 356 OVAL OUTER END ONLY

ALTERNATIVES

BRAKES
BOGIE/SUSPENSION
BODY CONSTRUCTION
COUPLINGS

TRAIN HEATING
MAX.SPEED M.P.H.
MIN.RAD.CURVE CHAINS
LIGHTING
TARE WEIGHT TONNES
GANGWAYS
A.W.S.
TRAIN COMMUNICATION
BUFFERS

TRACTION DATA FOR MULTIPLE UNITS

DEMU-BUILDER BR EASTLEIGH

BASIC TYPE

DE 302 0A

VARIANTS

NONE

DRIVING TRAILER COMPOSITE

CLASS 205

DTC

DE 303

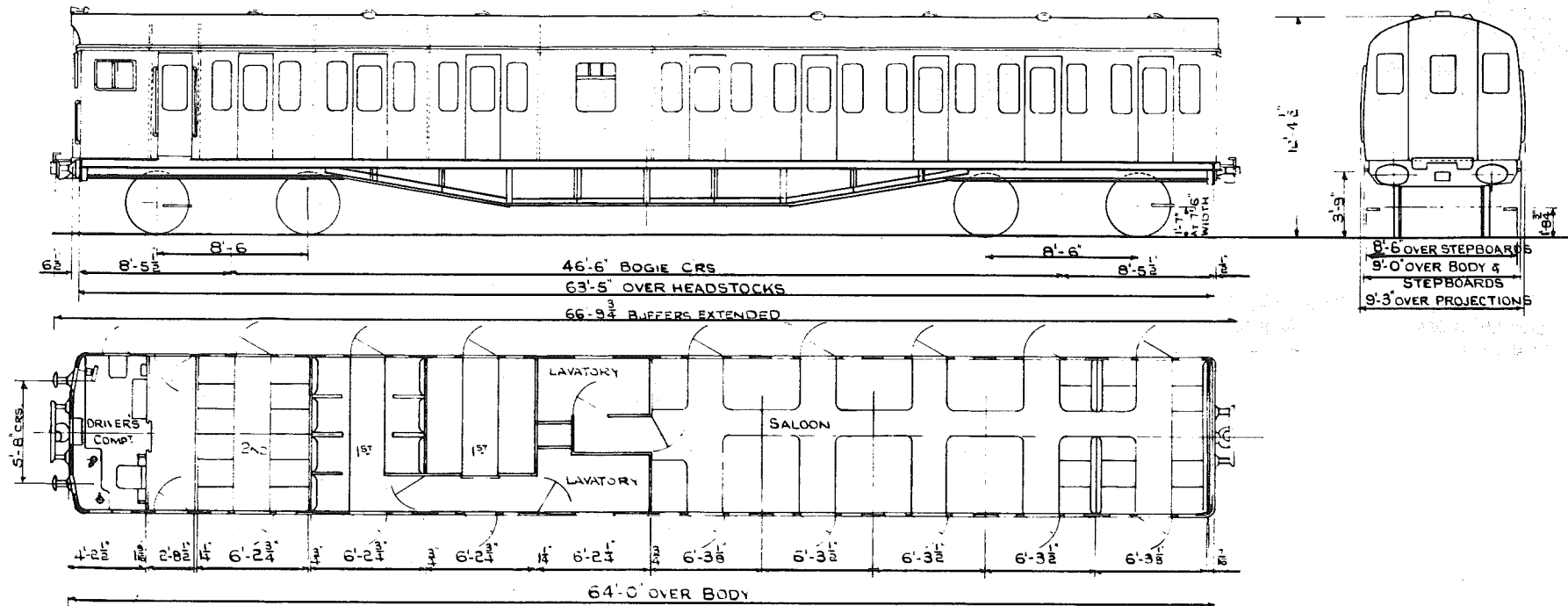

SEATS
TOILETS
COMPARTMENTS
GUARDS COMPARTMENTS
VENTILATION
CATERING EQUIPMENT

13 FIRST CLASS 42 SECOND CLASS
2
2 FIRST CLASS 1 SECOND CLASS PLUS SECOND CLASS SALOON
-
-
-

ORIGINAL DIAGRAMS FOR REFERENCE, -
BR 480

ISSUE 1 DATE SEP 80

DE 303

BRAKES
BOGIE/SUSPENSION
BODY CONSTRUCTION
COUPLINGS

TRAIN HEATING
MAX. SPEED M.P.H.
MIN. RAD. CURVE CHAINS
LIGHTING
TARE WEIGHT TONNES
GANGWAYS
A. V. S.
TRAIN COMMUNICATION
BUFFERS

BASIC TYPE

ELECTRO-PNEUMATIC
S.R. MK 4 UNPOWERED
STEEL
AUTOMATIC DROPHEAD (BUCKEYE) OUTER END-AUTOMATIC SOLID SHANK
(ALLIANCE NO.2) INNER END
ELECTRIC (BR)
75
3.5
ELECTRIC
34.5
NOT FITTED
FITTED
NOT FITTED
RETRACTABLE SPINDLE-559 X 356 OVAL OUTER END ONLY

ALTERNATIVES

TRACTION DATA FOR MULTIPLE UNITS

DEMU-BUILDER BR EASTLEIGH

BASIC TYPE

DE 303 0A

VARIANTS

NONE

TRAILER SECOND

CLASS 201

TS

DH 201

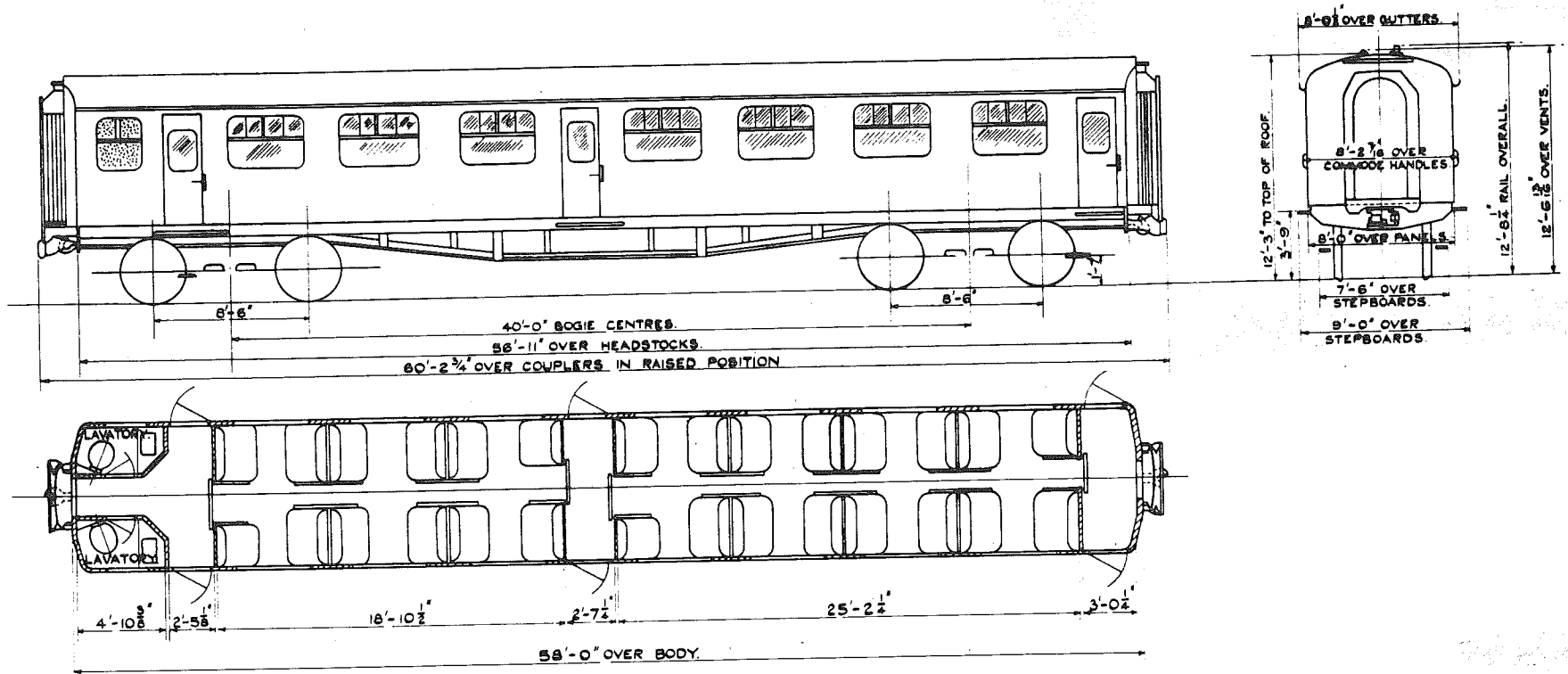

SEATS	52
TOILETS	2
COMPARTMENTS	-
GUARDS COMPARTMENTS	-
VENTILATION	-
CATERING EQUIPMENT	-

ORIGINAL DIAGRAMS FOR REFERENCE.-
BR 670

ISSUE 2 DATE DEC '81

DH 201

BRAKES
BOGIE/SUSPENSION
BODY CONSTRUCTION
COUPLINGS
TRAIN HEATING
MAX. SPEED M.P.H.
MIN. RAD. CURVE CHAINS
LIGHTING
TARE WEIGHT TONNES
GANGWAYS
TRAIN COMMUNICATION
BUFFERS

BASIC TYPE

ELECTRO-PNEUMATIC
S.R. MK 4 UNPOWERED
STEEL
AUTOMATIC SOLID SHANK (ALLIANCE NO.2)
ELECTRIC (BR)
75
3.5
ELECTRIC
29.5
EXPRESS ELECTRIC
NOT FITTED
NOT FITTED

ALTERNATIVES

TRACTION DATA FOR MULTIPLE UNITS

DEMU-BUILDER BR EASTLEIGH

BASIC TYPE

DH 201 0A

VARIANTS

NONE

TRAILER SECOND

CLASS 202
203

TS

DH 202

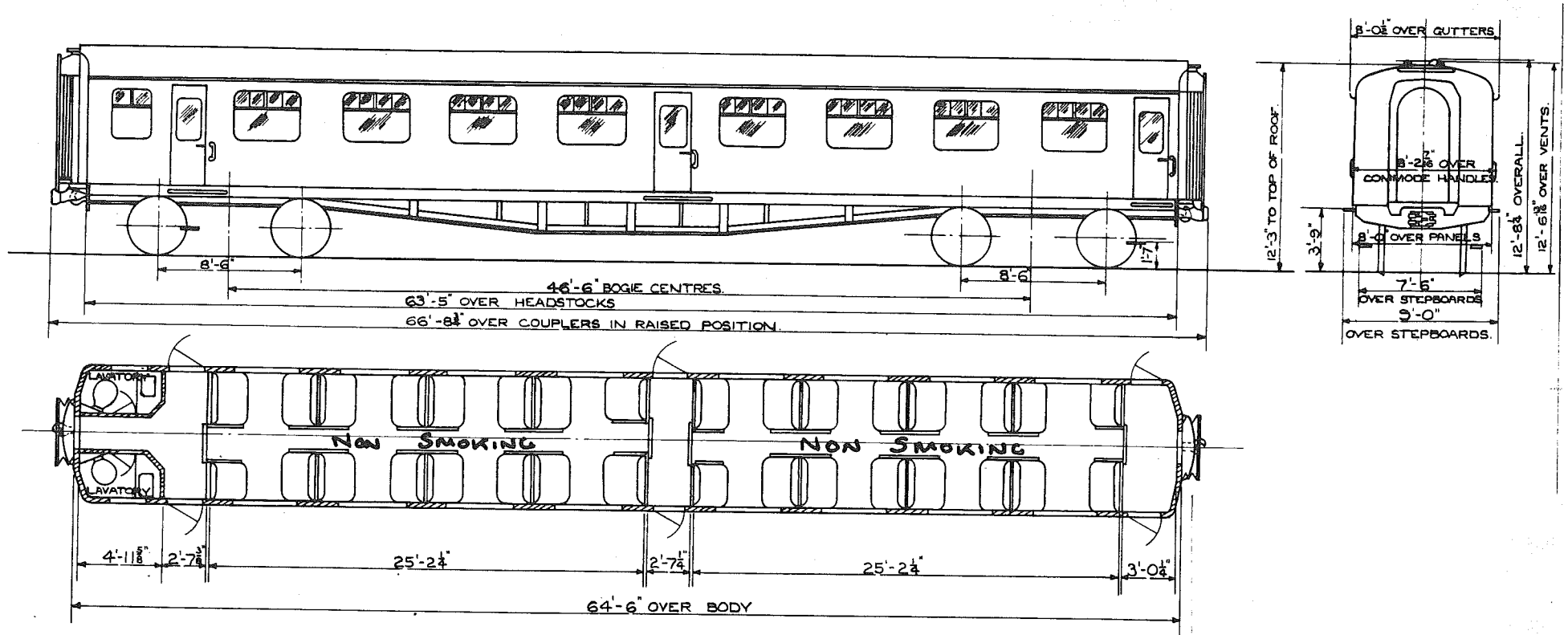

SEATS	60
TOILETS	2
COMPARTMENTS	-
GUARDS COMPARTMENTS	-
VENTILATION	-
CATERING EQUIPMENT	-

ORIGINAL DIAGRAMS FOR REFERENCE:-
BR 671

ISSUE 2 DATE NOV '84

DH 202

BRAKES
BOGIE/SUSPENSION
BODY CONSTRUCTION
COUPLINGS
TRAIN HEATING
MAX.SPEED M.P.H.
MIN.RAD.CURVE CHAINS
LIGHTING
TARE WEIGHT TONNES
GANGWAYS
TRAIN COMMUNICATION
BUFFERS

BASIC TYPE

ELECTRO-PNEUMATIC
S.R.MK 4 UNPOWERED
STEEL
AUTOMATIC SOLID SHANK(ALLIANCE NO.2)
ELECTRIC(BR)
75
3.5
TUNGSTEN
30.5
EXPRESS ELECTRIC
NOT FITTED
NOT FITTED

ALTERNATIVES

TRACTION DATA FOR MULTIPLE UNITS

DEMU-BUILDER BR EASTLEIGH

BASIC TYPE

DH 202 OA

VARIANTS

NONE

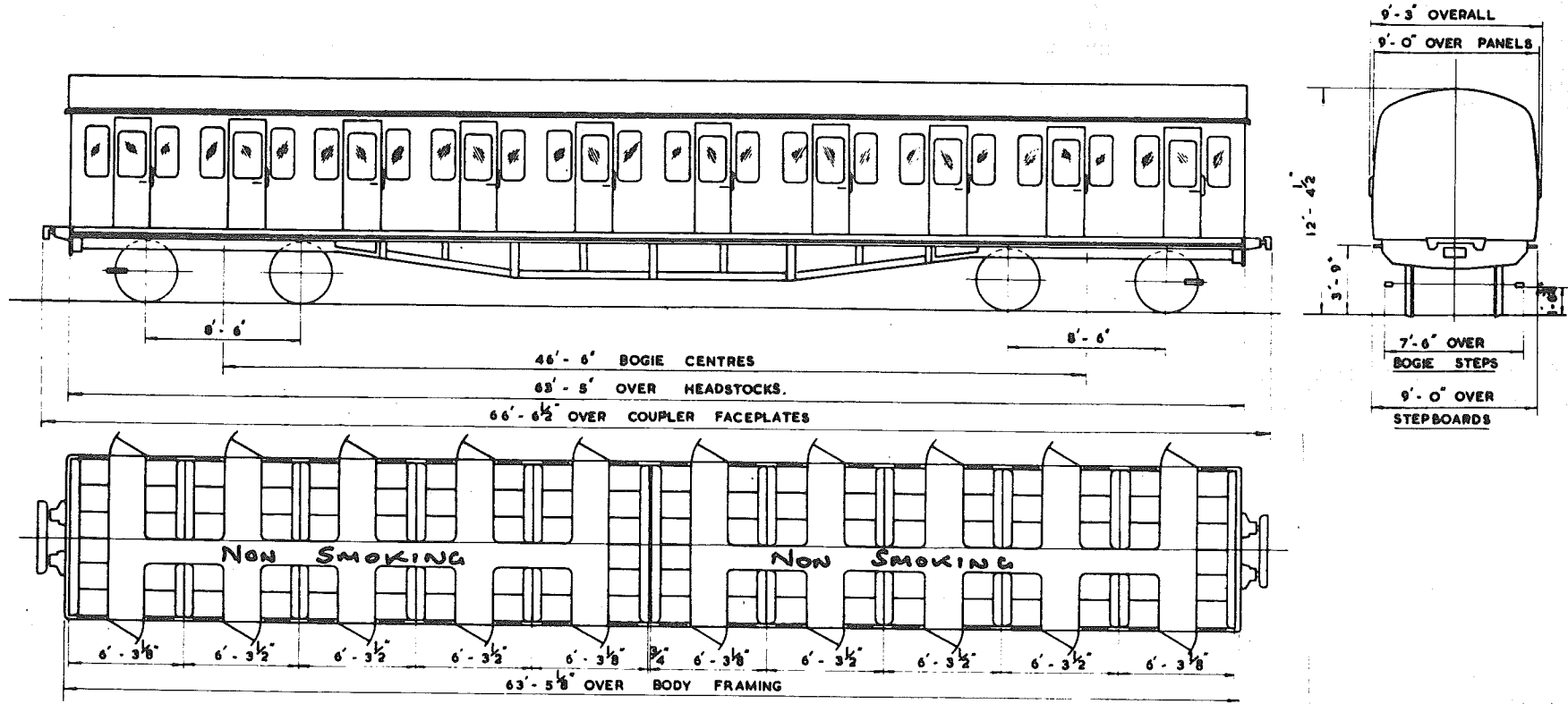

SEATS	104
TOILETS	-
COMPARTMENTS	-
GUARDS COMPARTMENTS	-
VENTILATION	-
CATERING EQUIPMENT	-

ORIGINAL DIAGRAMS FOR REFERENCE:-
BR 672

ISSUE 4 DATE NOV '84

DH 203

BRAKES
BOGIE/SUSPENSION
BODY CONSTRUCTION
COUPLINGS
TRAIN HEATING
MAX.SPEED M.P.H.
MIN.RAD.CURVE CHAINS
LIGHTING
TARE WEIGHT TONNES
GANGWAYS
TRAIN COMMUNICATION
BUFFERS

BASIC TYPE

ELECTRO-PNEUMATIC
S.R.MK 4 UNPOWERED
STEEL
AUTOMATIC SOLID SHANK (ALLIANCE NO.2)
ELECTRIC (BR)
75
3.5
TUNGSTEN
30.5
NOT FITTED
NOT FITTED
NOT FITTED

ALTERNATIVES

FLUORESCENT

TRACTION DATA FOR MULTIPLE UNITS

DEMU-BUILDER BR EASTLEIGH

BASIC TYPE

DH 203 OA

VARIANTS

1B CLASS 205/1-PROTOTYPE REFURBISHED VEHICLE-FLUORESCENT & TUNGSTEN LIGHTING.

TRAILER SECOND

CLASS 210

TS

DH 205

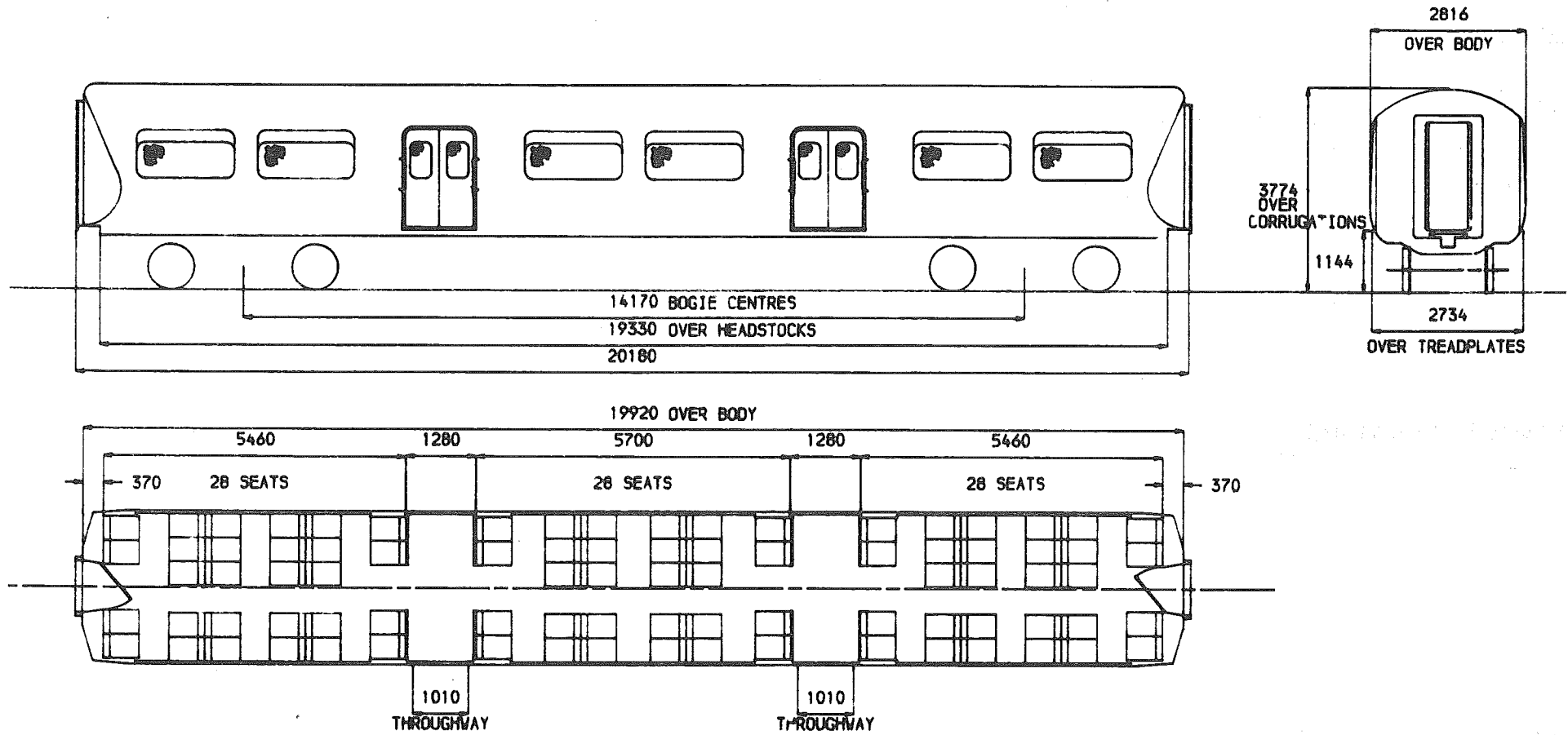

SEATS	84
TOILETS	-
COMPARTMENTS	-
GUARDS COMPARTMENTS	-
VENTILATION	PRESSURE
CATFRING EQUIPMENT	-

ISSUE	DATE
3	AUG '82

DH 205

BASIC TYPE

BRAKES
BOGIE/SUSPENSION
BODY CONSTRUCTION
COUPLINGS
TRAIN HEATING
MAX. SPEED H.P.H.
MIN. RAD. CURVE CHAINS
LIGHTING
TARE WEIGHT TONNES
GANGWAYS
TRAIN COMMUNICATION
BUFFERS

ELECTRO-PNEUMATIC (WESTCODE)
BT13
STEEL
BAR
ELECTRIC (BR) WITH PRESSURE VENTILATION & HEATING
90
3.5
FLUORESCENT
26.5
FLEXIBLE DIAPHRAGM/RIGID (GRP)
PUBLIC ADDRESS
NOT FITTED

ALTEPNATIVES

TRACTION DATA FOR MULTIPLE UNITS

DEMU-BUILDER BR DERBY-PROTOTYPE

BASIC TYPE

DH 205 0A

VARIANTS

NONE

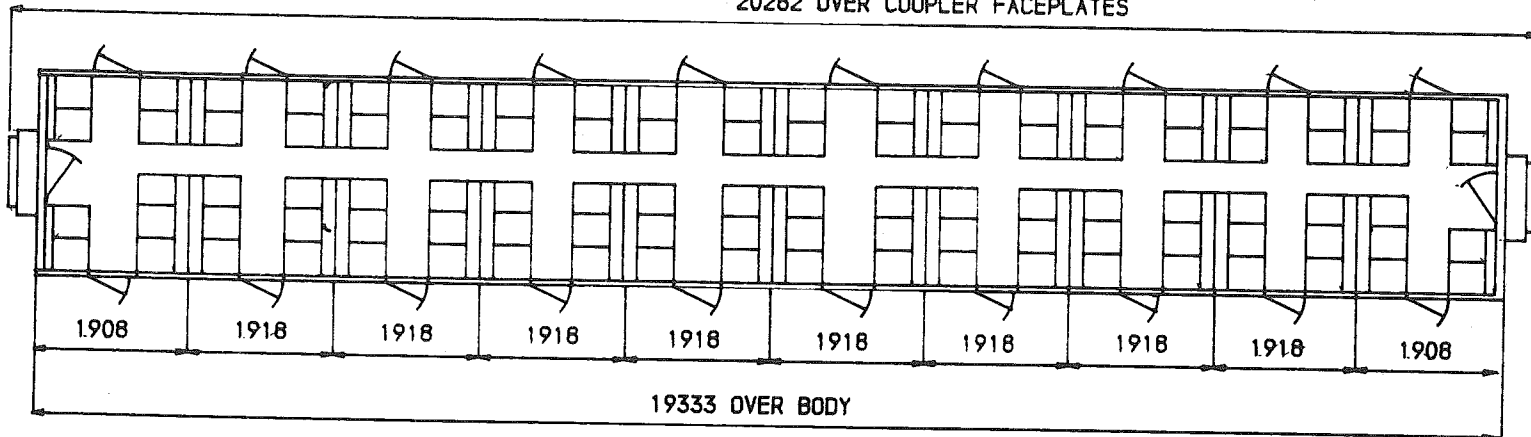
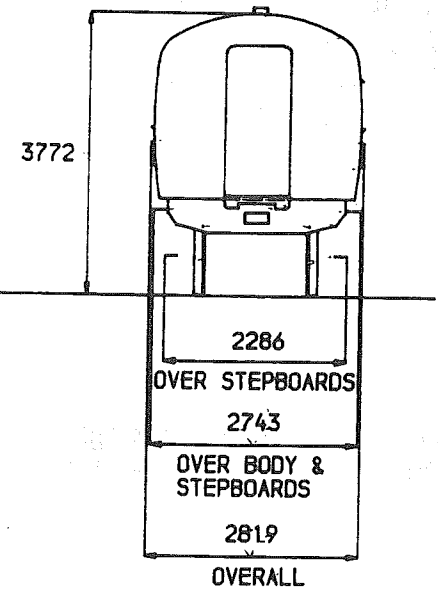
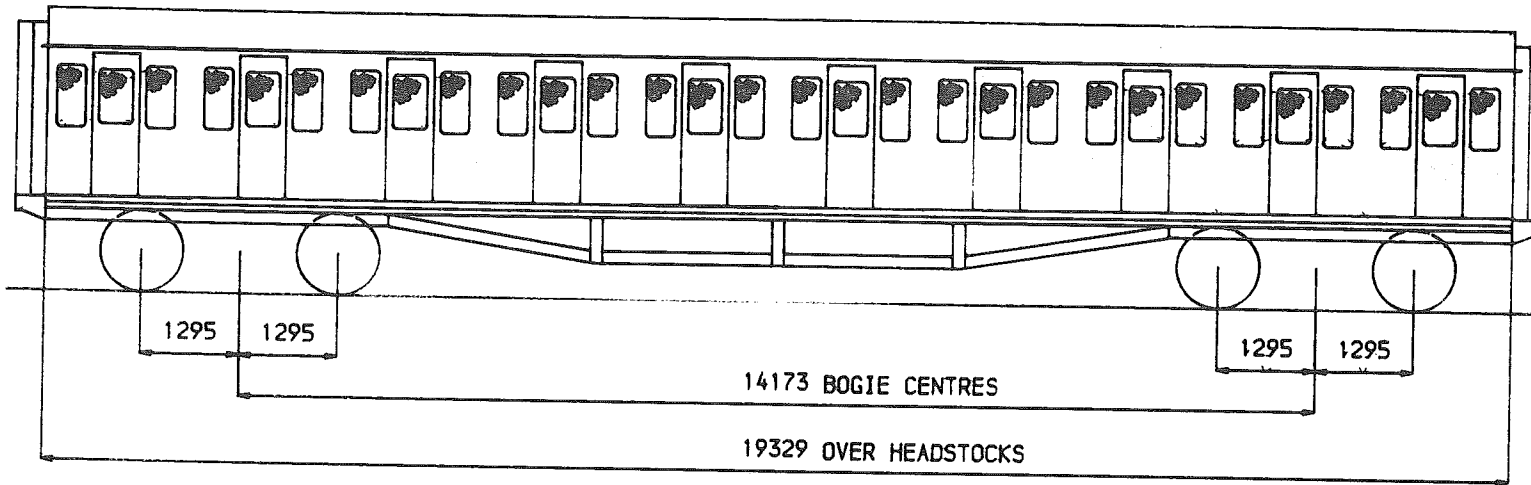

SEATS	98
TOILETS	-
COMPARTMENTS	-
GUARDS COMPARTMENTS	-
VENTILATION	-
CATERING EQUIPMENT	-

ISSUE 2. DATE DEC' 81

DH 206

BASIC TYPE

BRAKES
BOGIE/SUSPENSION
BODY CONSTRUCTION
COUPLINGS
TRAIN HEATING
MAX. SPEED M.P.H.
MIN. RAD. CURVE CHAINS
LIGHTING
TARE WEIGHT TONNES
GANGWAYS
TRAIN COMMUNICATION
BUFFERS

ELECTRO-PNEUMATIC
S.R. MK 4 UNPOWERED
STEEL
AUTOMATIC SOLID SHANK (ALLIANCE NO 2)
ELECTRIC (BR)
75
3.5
FLUORESCENT
30.5
PULLMAN WITH RIGID (GRP) INNER PANELS
NOT FITTED
NOT FITTED

ALTERNATIVES

TRACTION DATA FOR MULTIPLE UNITS

DEMU-BUILDER BR EASTLIEGH - REFURBISHED 1980 (PROTOTYPE)

BASIC TYPE

DH 206 0A

VARIANTS

NONE

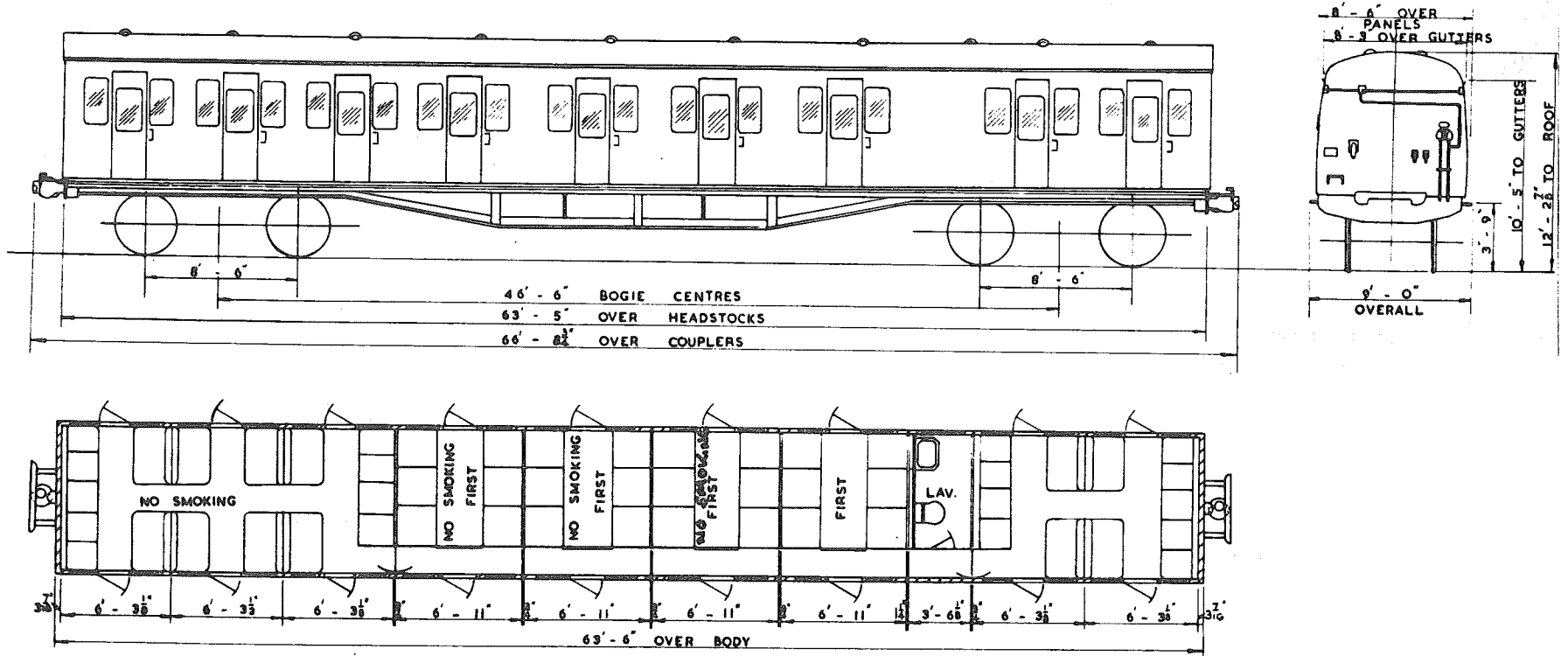

- | | |
|---------------------|---|
| SEATS | 24 FIRST CLASS 42 SECOND CLASS |
| TOILETS | 1 |
| COMPARTMENTS | 4 FIRST CLASS PLUS 2 SECOND CLASS SALOONS |
| GUARDS COMPARTMENTS | - |
| VENTILATION | - |
| CATERING EQUIPMENT | - |

ORIGINAL DIAGRAMS FOR REFERENCE:-
BR 667

ISSUE 2 DATE NOV '84

DH 301

BASIC TYPE

ELECTRO-PNEUMATIC
S.R.MK 3A UNPOWERED
STEEL
AUTOMATIC SOLID SHANK (ALLIANCE NO.2)
ELECTRIC (BR)
75
3.5
TUNGSTEN
31.5
NOT FITTED
NOT FITTED
NOT FITTED

ALTERNATIVES

BRAKES
BOGIE/SUSPENSION
BODY CONSTRUCTION
COUPLINGS
TRAIN HEATING
MAX.SPEED M.P.H.
MIN.RAD.CURVE CHAINS
LIGHTING
TARE WEIGHT TONNES
GANGWAYS
TRAIN COMMUNICATION
BUFFERS

TRACTION DATA FOR MULTIPLE UNITS

DEMU-BUILDER BR EASTLEIGH

BASIC TYPE

DH 301 OA

VARIANTS

NONE

TRAILER COMPOSITE

CLASS 210

TC

DH 302

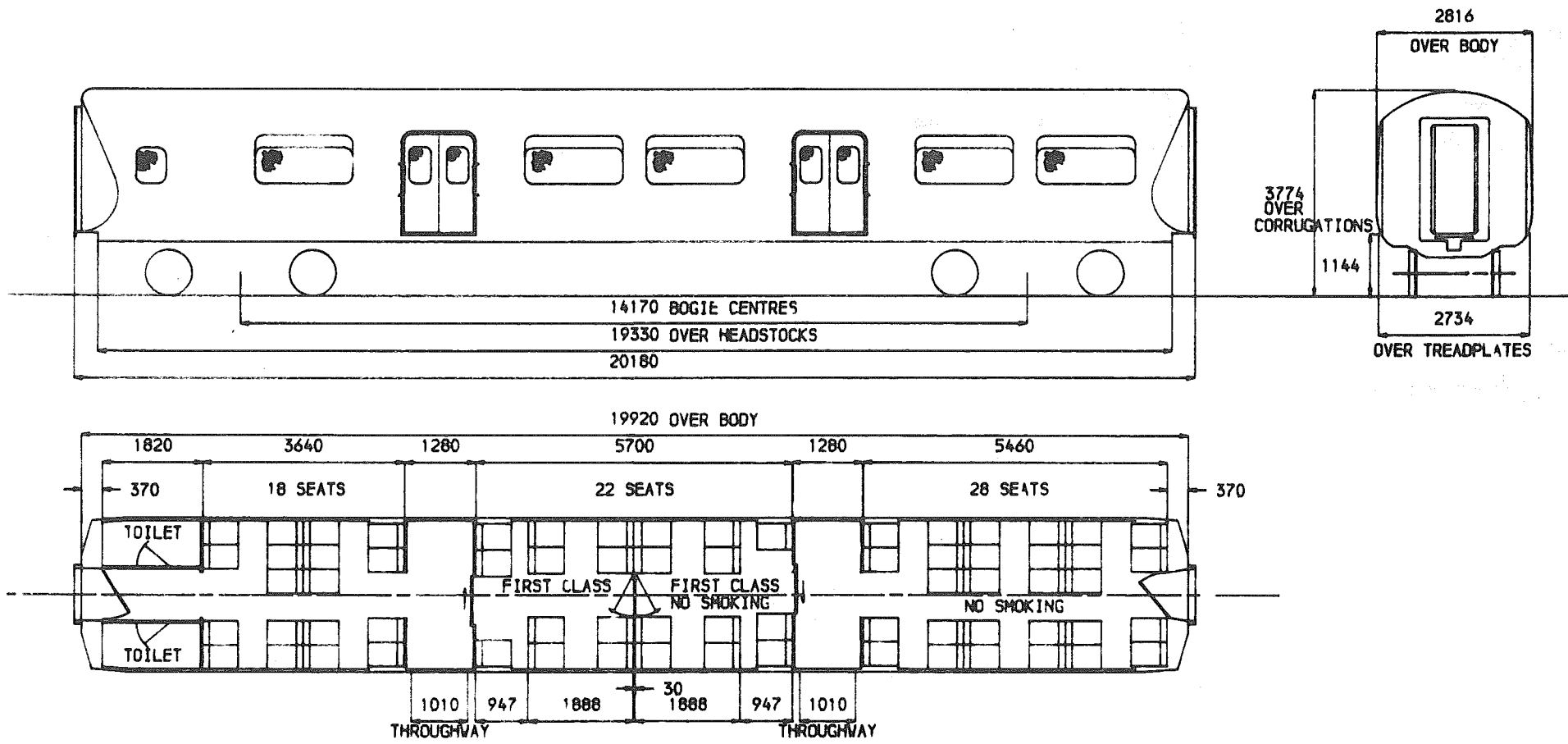

- | | |
|---------------------|--------------------------------|
| SEATS | 22 FIRST CLASS 46 SECOND CLASS |
| TOILETS | 2 |
| COMPARTMENTS | - |
| GUARDS COMPARTMENTS | - |
| VENTILATION | PRESSURE |
| CATERING EQUIPMENT | - |

ISSUE 2 DATE AUG' 82

DH 302

BASIC TYPE

BRAKES
BOGIE/SUSPENSION
BODY CONSTRUCTION
COUPLINGS
TRAIN HEATING
MAX. SPEED M.P.H.
MIN. RAD. CURVE CHAINS
LIGHTING
TARE WEIGHT TONNES
GANGWAYS
TRAIN COMMUNICATION
BUFFERS

ELECTRO-PNEUMATIC (WESTCODE)
BT13
STEEL
BAR
ELECTRIC (BR) WITH PRESSURE VENTILATION & HEATING
90
3.5
FLUORESCENT & TUNGSTEN
26.5
FLEXIBLE DIAPHRAGM/RIGID (GRP)
PUBLIC ADDRESS
NOT FITTED

ALTERNATIVES

TRACTION DATA FOR MULTIPLE UNITS

DEMU-BUILDER BR DERBY-PROTOTYPE

BASIC TYPE

D4 302 0A

VARIANTS

NONE

TRAILER COMPOSITE

CLASS 201

TC

DH 303

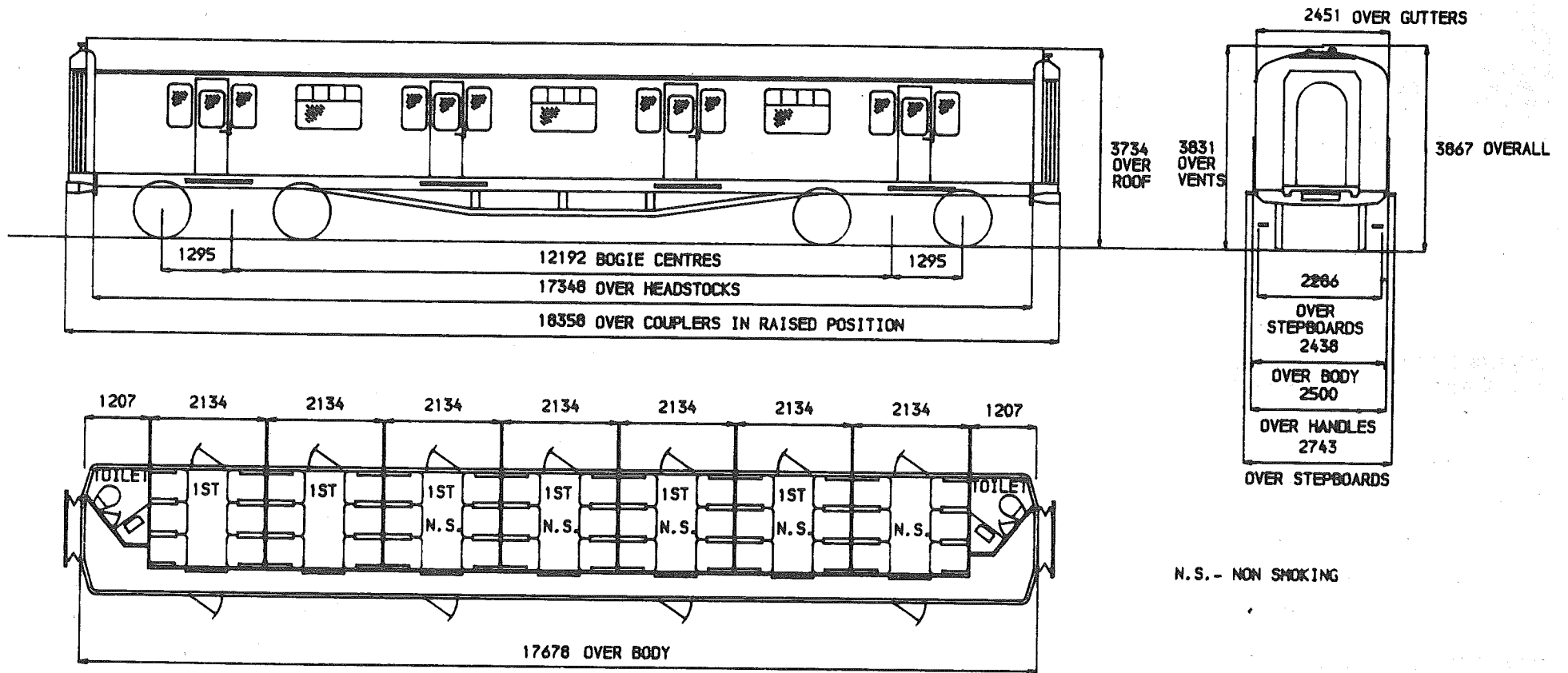

N.S. - NON SMOKING

SEATS	36 FIRST CLASS 6 SECOND CLASS
TOILETS	2
COMPARTMENTS	6 FIRST CLASS 1 SECOND CLASS
GUARDS COMPARTMENTS	-
VENTILATION	-
CATERING EQUIPMENT	-

ORIGINAL DIAGRAMS FOR REFERENCE.-
BR 660

ISSUE	DATE
1	JUN '81

DH 303

BRAKES
BOGIE/SUSPENSION
BODY CONSTRUCTION
COUPLINGS
TRAIN HEATING
MAX. SPEED M.P.H.
MIN. RAD. CURVE CHAINS
LIGHTING
TARE WEIGHT TONNES
GANGWAYS
A.V.S.
TRAIN COMMUNICATION
BUFFERS

BASIC TYPE

ELECTRO PNEUMATIC
S.R. MK 4 UNPOVERED
STEEL
AUTOMATIC SOLID SHANK (ALLIANCE NO 2)
ELECTRIC (BR)
75
3.5
TUNGSTEN
30.5
EXPRESS ELECTRIC
NOT FITTED
NOT FITTED
NOT FITTED

ALTERNATIVES

TRACTION DATA FOR MULTIPLE UNITS

DEMU-BUILDER BR EASTLEIGH

BASIC TYPE

DH 303 0A

VARIANTS

NONE

TRAILER COMPOSITE

CLASS 201
202
203

TC

DH 304

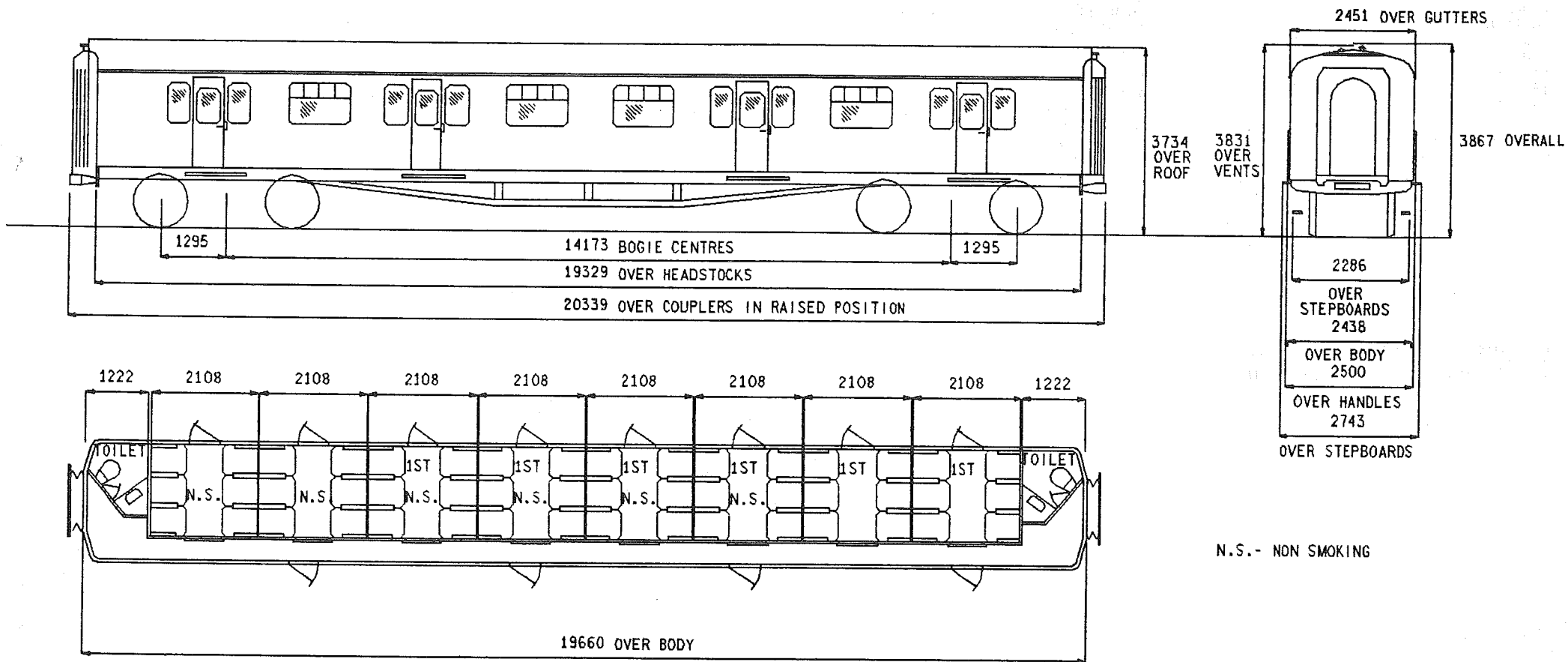

N.S.- NON SMOKING

SEATS	36 FIRST CLASS 12 SECOND CLASS
TOILETS	2
COMPARTMENTS	6 FIRST CLASS 2 SECOND CLASS
GUARDS COMPARTMENTS	-
VENTILATION	-
CATERING EQUIPMENT	-

ORIGINAL DIAGRAMS FOR REFERENCE:-
BR 661

ISSUE 2 DATE NOV '84

DH 304

BRAKES
BOGIE/SUSPENSION
BODY CONSTRUCTION
COUPLINGS
TRAIN HEATING
MAX.SPEED M.P.H.
MIN.RAD.CURVE CHAINS
LIGHTING
TARE WEIGHT TONNES
GANGWAYS
A.W.S.
TRAIN COMMUNICATION
BUFFERS

BASIC TYPE

ELECTRO PNEUMATIC
S.R.MK 4 UNPOWERED
STEEL
AUTOMATIC SOLID SHANK (ALLIANCE NO 2)
ELECTRIC (BR)
75
3.5
TUNGSTEN
31.5
EXPRESS ELECTRIC
NOT FITTED
NOT FITTED
NOT FITTED

ALTERNATIVES

TRACTION DATA FOR MULTIPLE UNITS

DEMU-BUILDER BR EASTLEIGH

BASIC TYPE

DH 304 OA

VARIANTS

NONE

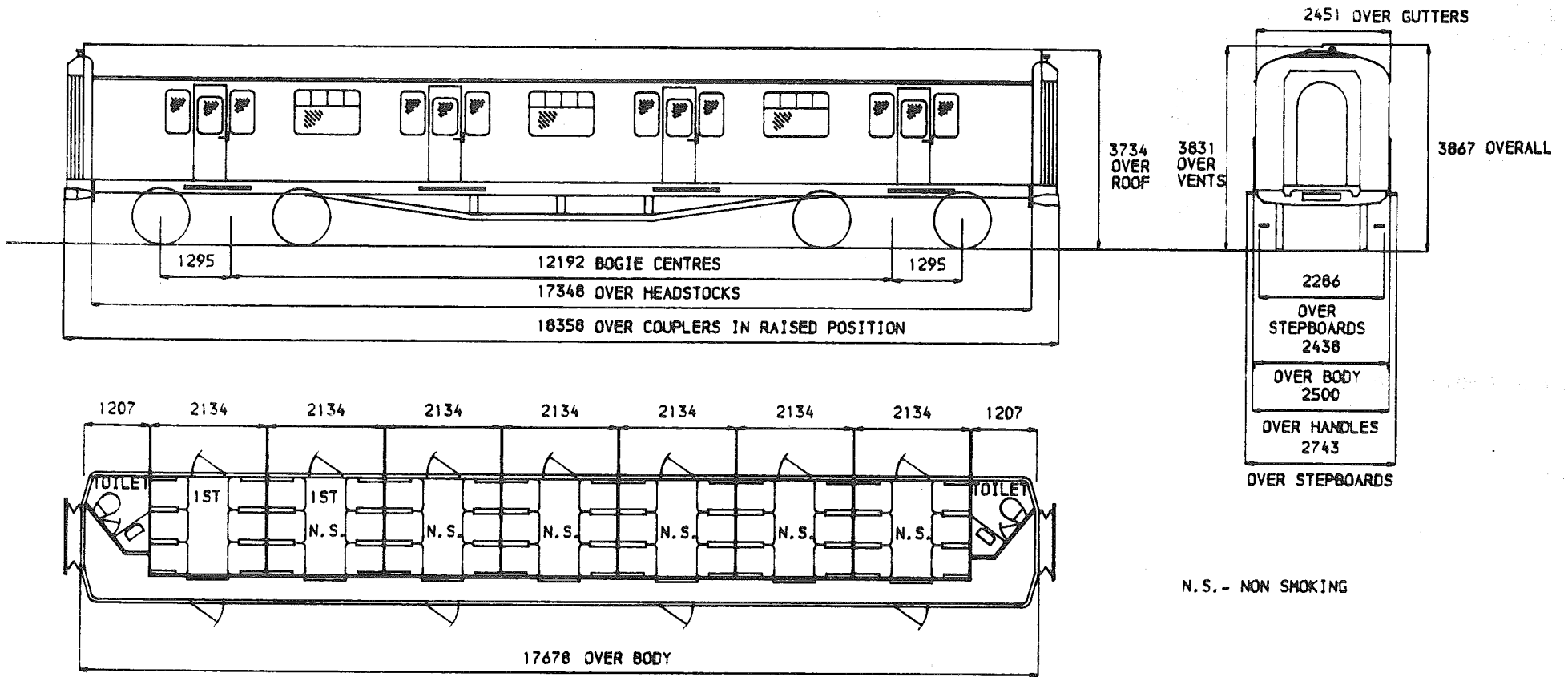

N.S. - NON SMOKING

SEATS	12 FIRST CLASS 30 SECOND CLASS
TOILETS	2
COMPARTMENTS	2 FIRST CLASS 5 SECOND CLASS
GUARDS COMPARTMENTS	-
VENTILATION	-
CATERING EQUIPMENT	-

ORIGINAL DIAGRAMS FOR REFERENCE, -
BR 660

ISSUE DATE
1 JUN '81

DH 305

BRAKES
BOGIE/SUSPENSION
BODY CONSTRUCTION
COUPLINGS
TRAIN HEATING
MAX. SPEED M.P.H.
MIN. RAD. CURVE CHAINS
LIGHTING
TARE VEIGHT TONNES
GANGWAYS
A.V.S.
TRAIN COMMUNICATION
BUFFERS

BASIC TYPE

ELECTRO PNEUMATIC
S.R. MK 4 UNPOWERED
STEEL
AUTOMATIC SOLID SHANK (ALLIANCE NO 2)
ELECTRIC (BR)
75
3.5
TUNGSTEN
30.5
EXPRESS ELECTRIC
NOT FITTED
NOT FITTED
NOT FITTED

ALTERNATIVES

TRACTION DATA FOR MULTIPLE UNITS

DEMU-BUILDER BR EASTLEIGH

BASIC TYPE

DH 305 0A

VARIANTS

NONE

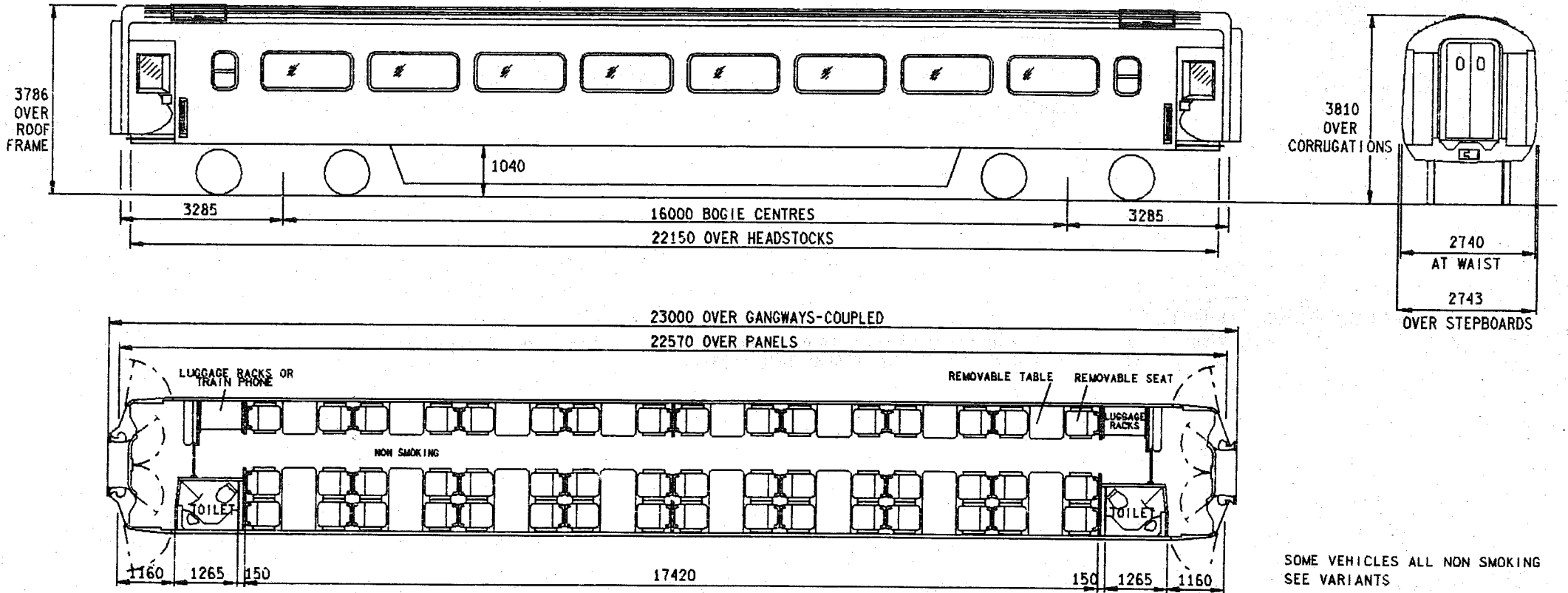

SOME VEHICLES ALL NON SMOKING
SEE VARIANTS

SEATS	48
TOILETS	2
COMPARTMENTS	-
GUARDS COMPARTMENTS	-
VENTILATION	FULL AIR CONDITIONING
CATERING EQUIPMENT	-

ORIGINAL DIAGRAMS FOR REFERENCE:-
BR 666

ISSUE 7 DATE MAR 87

GH 102

BRAKES
BOGIE/SUSPENSION
BODY CONSTRUCTION
COUPLINGS
TRAIN HEATING
MAX.SPEED M.P.H.
MIN.RAD.CURVE CHAINS
LIGHTING
TARE WEIGHT TONNES
GANGWAYS
TRAIN COMMUNICATION
BUFFERS
SEATS

BASIC TYPE

AIR
BT10
STEEL
AUTOMATIC SOLID SHANK(ALLIANCE No 2 LONG SHANK)
ELECTRIC(BR)FULL AIR CONDITIONING
125
4.5
FLUORESCENT & TUNGSTEN
33
CENTRALLY SUPPORTED-SWIVELLING-FLEXIBLE DIAPHRAGM-STEEL FACE PLATE
PUBLIC ADDRESS
NOT FITTED
INTER-CITY 70

ALTERNATIVES

BT10b-CLASS 253

4.1

33.5

PA + TRAIN PHONE

IC 80

TRACTION DATA FOR MULTIPLE UNITS

HST- INTRODUCED CLASS 253 WESTERN REGION 1976, WEST OF ENGLAND 1979, NORTHEAST/SOUTHWEST INTRODUCED 1981,
CLASS 254 EASTERN REGION 1978, DECLASSIFIED 1987.

BASIC TYPE

GH 102 OA

VARIANTS

0B BT10b-CLASS 253 BOGIES, TARE 33.5.
0D BT10b-CLASS 253 BOGIES, TARE 33.5, IC 80 SEATS.
0E ALL NON SMOKING.
0F ALL NON SMOKING, BT10b-CLASS 253 BOGIES, TARE 33.5.
1C CONVERTED PROTOTYPE, 4.1 MIN.RAD.CURVE
1G ALL NON SMOKING, CONVERTED PROTOTYPE, 4.1 MIN.RAD.CURVE
2A TRAIN PHONE.
2B BT10b-CLASS 253 BOGIES, TARE 33.5, TRAIN PHONE.
2D BT10b-CLASS 253 BOGIES, TARE 33.5, TRAIN PHONE, IC 80 SEATS.
2E TRAIN PHONE, ALL NON SMOKING.

TRAILER FIRST-HST

CLASS ---

TF

GH 103

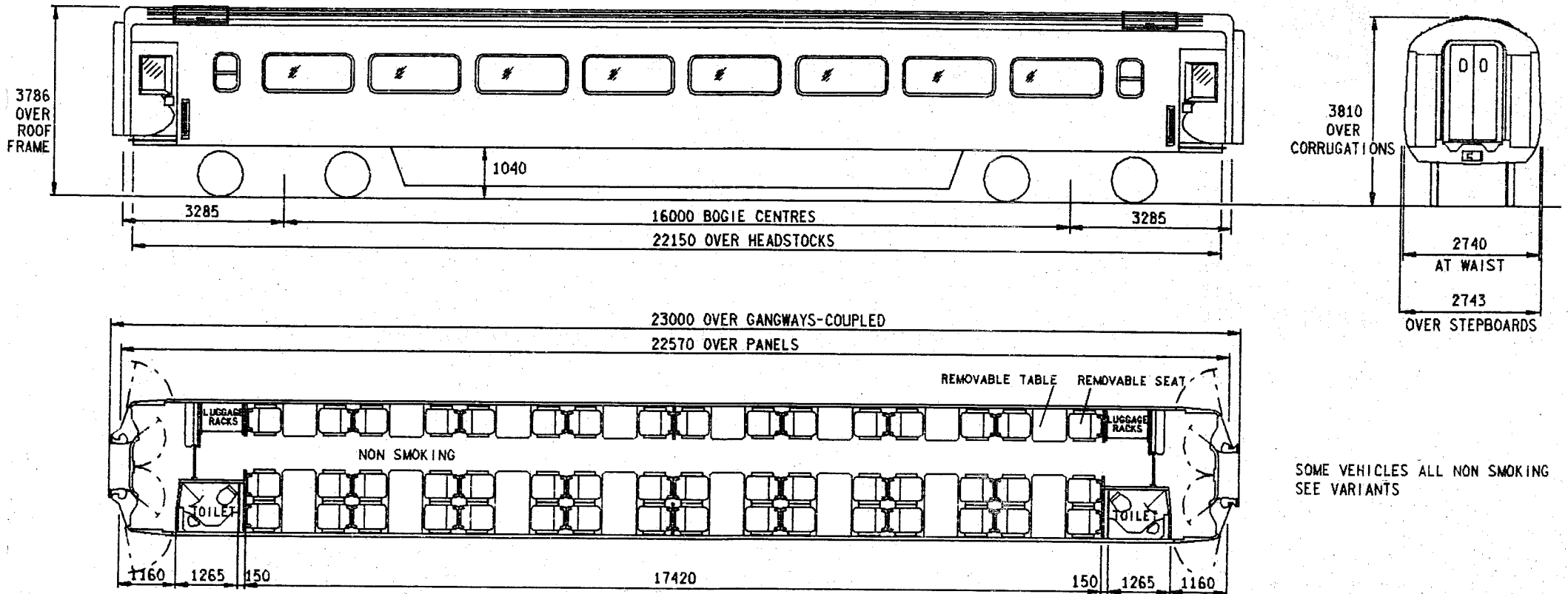

SOME VEHICLES ALL NON SMOKING
SEE VARIANTS

- | | |
|---------------------|-----------------------|
| SEATS | 48 |
| TOILETS | 2 |
| COMPARTMENTS | - |
| GUARDS COMPARTMENTS | - |
| VENTILATION | FULL AIR CONDITIONING |
| CATERING EQUIPMENT | - |

ISSUE 2 DATE MAY 81

GH 103

BRAKES
BOGIE/SUSPENSION
BODY CONSTRUCTION
COUPLINGS
TRAIN HEATING
MAX.SPEED M.P.H.
MIN.RAD.CURVE CHAINS
LIGHTING
TARE WEIGHT TONNES
GANGWAYS
TRAIN COMMUNICATION
BUFFERS

BASIC TYPE

AIR
BT10
STEEL
AUTOMATIC SOLID SHANK(ALLIANCE No 2 LONG SHANK)
ELECTRIC(BR)FULL AIR CONDITIONING
125
4.1
FLUORESCENT & TUNGSTEN
34
CENTRALLY SUPPORTED-SWIVELLING-FLEXIBLE DIAPHRAGM-STEEL FACE PLATE
PUBLIC ADDRESS
NOT FITTED

ALTERNATIVES

TRACTION DATA FOR MULTIPLE UNITS

HST-

CLASS 254 EASTERN REGION 1978,RECLASSIFIED - MOD X1M103/001 1983,DECLASSIFIED 1987.

BASIC TYPE

GH 103 0A.

VARIANTS

OB ALL NON SMOKING.

TRAILER SECOND-HST

CLASS ---

TS

GH 202

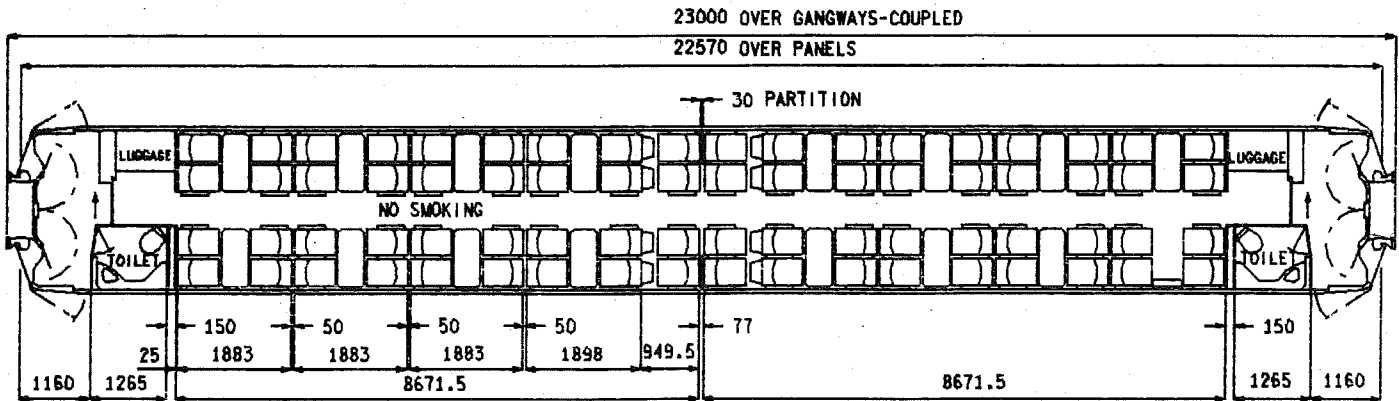
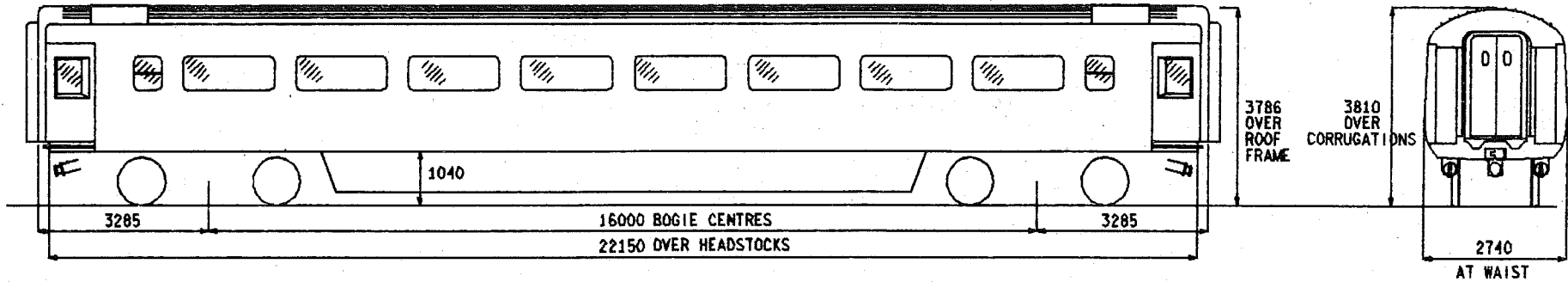

SOME VEHICLES ALL NON SMOKING
SEE VARIANTS

SEATS
TOILETS
COMPARTMENTS
GUARDS COMPARTMENTS
VENTILATION
CATERING EQUIPMENT

72
2
-
-
FULL AIR CONDITIONING
-

ORIGINAL DIAGRAMS FOR REFERENCE:-
BR 675

ISSUE DATE
3 MAR 87
(visit <http://www.barrowmoremrg.co.uk>)

GH 202

BRAKES
BOGIE/SUSPENSION
BODY CONSTRUCTION
COUPLINGS
TRAIN HEATING
MAX.SPEED M.P.H.
MIN.RAD.CURVE CHAINS
LIGHTING
TARE WEIGHT TONNES
GANGWAYS

TRAIN COMMUNICATION
BUFFERS

BASIC TYPE

AIR
BT10
STEEL
AUTOMATIC SOLID SHANK (ALLIANCE NO.2-LONG SHANK)
ELECTRIC (BR) FULL AIR CONDITIONING
125
4.5
FLUORESCENT & TUNGSTEN
35
CENTRALLY SUPPORTED-SWIVELLING-FOAM DIAPHRAGM-STEEL FACE PLATE
PUBLIC ADDRESS
NOT FITTED

ALTERNATIVES

BT10b

34,33.5
CENTRALLY SUPPORTED-SWIVELLING-FLEXIBLE DIAPHRAGM-
STEEL FACE PLATE

TRACTION DATA FOR MULTIPLE UNITS

HST-

INTRODUCED-CLASS 253 W.R.1976,W.OF ENGLAND 1979,NORTHEAST/SOUTHWEST 1981-CLASS 254 E.R.1978.DECLASSIFIED 1987.

BASIC TYPE

GH 202 OA

VARIANTS

OB TARE 34,GANGWAY HAS FLEXIBLE DIAPHRAGM.
OC TARE 33.5,GANGWAY HAS FLEXIBLE DIAPHRAGM,BT10b BOGIES.
OD ALL NON SMOKING.
OE TARE 34,GANGWAY HAS FLEXIBLE DIAPHRAGM,ALL NON SMOKING.
OF TARE 33.5,GANGWAY HAS FLEXIBLE DIAPHRAGM,BT10b BOGIES,ALL NON SMOKING.

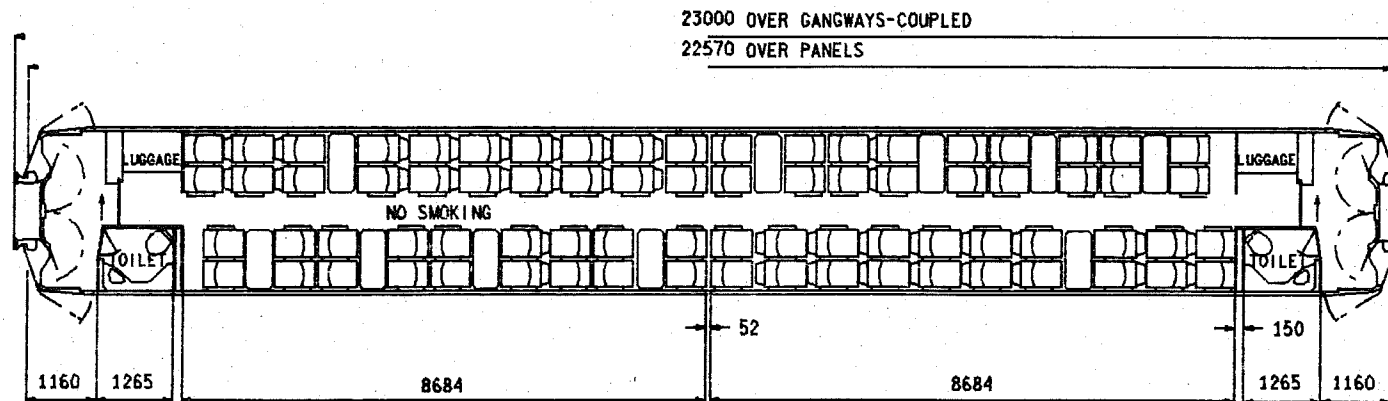
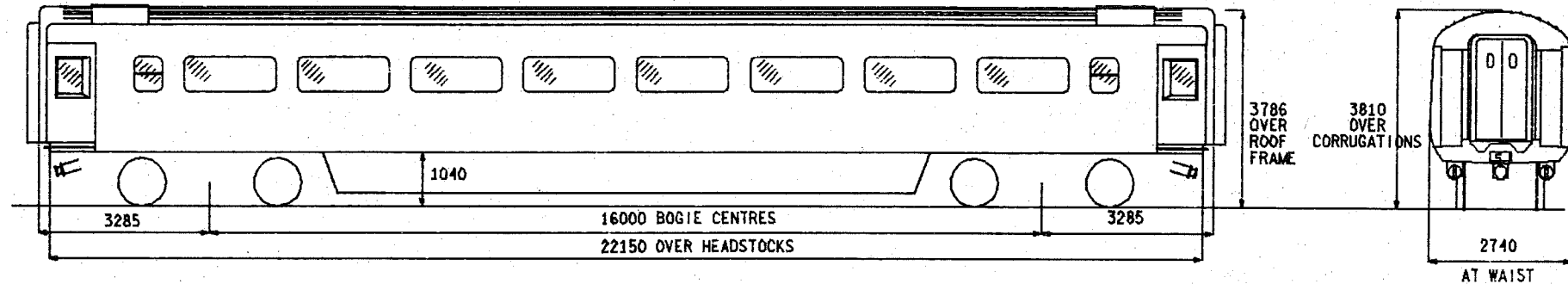

SOME VEHICLES ALL NON SMOKING
SEE VARIANTS

SEATS	76
TOILETS	2
COMPARTMENTS	-
GUARDS COMPARTMENTS	-
VENTILATION	FULL AIR CONDITIONING
CATERING EQUIPMENT	-

ISSUE DATE
5 MAR 87

GH 203

BRAKES
BOGIE/SUSPENSION
BODY CONSTRUCTION
COUPLINGS
TRAIN HEATING
MAX.SPEED M.P.H.
MIN.RAD.CURVE CHAINS
LIGHTING
TARE WEIGHT TONNES
GANGWAYS
TRAIN COMMUNICATION
BUFFERS
SEATS

BASIC TYPE

AIR
BT10 b
STEEL
AUTOMATIC SOLID SHANK (ALLIANCE NO.2-LONG SHANK)
ELECTRIC (BR) FULL AIR CONDITIONING
125
4.5
FLUORESCENT & TUNGSTEN
33.5
CENTRALLY SUPPORTED-SWIVELLING-FLEXIBLE DIAPHRAGM-STEEL FACE PLATE
PUBLIC ADDRESS
NOT FITTED
INTER CITY 70

ALTERNATIVES

BT10 d

A.P.T.

TRACTION DATA FOR MULTIPLE UNITS

HST- INTRODUCED-CLASS 253 W.R.1976,W.OF ENGLAND 1979,NORTHEAST/SOUTHWEST 1981.
MODIFIED FOR EXECUTIVE HST 1983,DECLASSIFIED 1987.

BASIC TYPE

GH 203 OA

VARIANTS

OB A.P.T. SEATS
OC BT10 d BOGIES
OD ALL NON SMOKING.
OE A.P.T. SEATS, ALL NON SMOKING.
OF BT10 d BOGIES, ALL NON SMOKING.

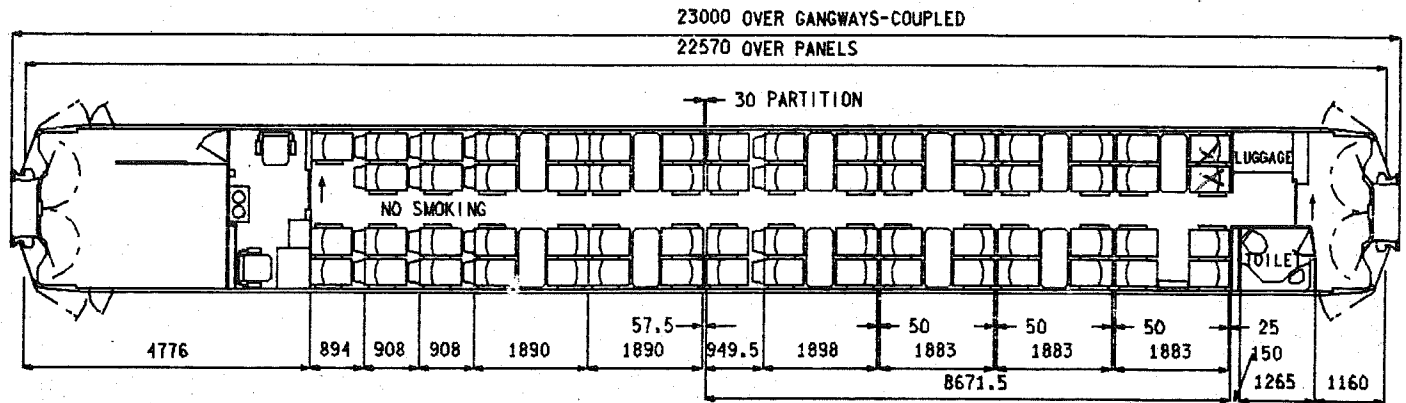
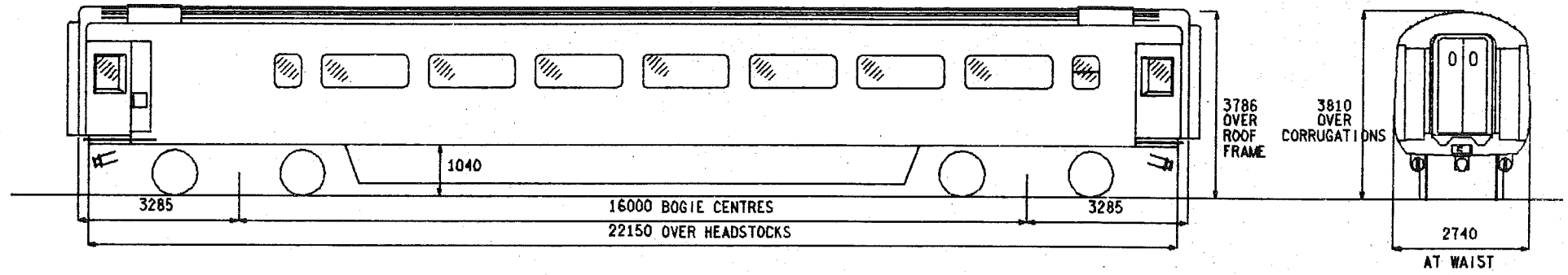

- | | |
|---------------------|-----------------------|
| SEATS | 63 |
| TOILETS | 1 |
| COMPARTMENTS | - |
| GUARDS COMPARTMENTS | 1 |
| VENTILATION | FULL AIR CONDITIONING |
| CATERING EQUIPMENT | - |

ORIGINAL DIAGRAMS FOR REFERENCE:-
BR 676

ISSUE 3
DATE MAR 87

GJ 201

BRAKES
BOGIE/SUSPENSION
BODY CONSTRUCTION
COUPLINGS
TRAIN HEATING
MAX.SPEED M.P.H.
MIN.RAD.CURVE CHAINS
LIGHTING
TARE WEIGHT TONNES
GANGWAYS
TRAIN COMMUNICATION
BUFFERS

BASIC TYPE

AIR
BT10b
STEEL
AUTOMATIC SOLID SHANK (ALLIANCE NO.2-LONG SHANK)
ELECTRIC (BR) FULL AIR CONDITIONING
125
4.5
FLUORESCENT & TUNGSTEN
33.5
CENTRALLY SUPPORTED-SWIVELLING-FLEXIBLE DIAPHRAGM-STEEL FACE PLATE
PUBLIC ADDRESS WITH TRANSMITTER
NOT FITTED

ALTERNATIVES

TRACTION DATA FOR MULTIPLE UNITS

HST- INTRODUCED 1983, DECLASSIFIED 1987.

BASIC TYPE

GJ 201 0A

VARIANTS

NONE

GK 101

BRAKES
BOGIE/SUSPENSION
BODY CONSTRUCTION
COUPLINGS
TRAIN HEATING
MAX. SPEED M.P.H.
MIN. RAD. CURVE CHAINS
LIGHTING
TARE WEIGHT TONNES
GANGWAYS
TRAIN COMMUNICATION
BUFFERS
SEATS

BASIC TYPE

AIR
BT10 & BT10a(ONE OF EACH)
STEEL
AUTOMATIC SOLID SHANK(ALLIANCE NO 2 LONG SHANK)
ELECTRIC(BR) FULL AIR CONDITIONING
125
4.5
FLUORESCENT & TUNGSTEN
38
CENTRALLY SUPPORTED-SWIVELING-FLEXIBLE DIAPHRAGM-STEEL FACE PLATE
PUBLIC ADDRESS & TRANSMITTER
NOT FITTED
INTER-CITY 80

ALTERNATIVES

BT10b & BT10c(ONE OF EACH)

39

TRACTION DATA FOR MULTIPLE UNITS

HST INTRODUCED-EASTERN REGION 1978, RECLASSIFIED 1985, DECLASSIFIED 1987.

BASIC TYPE

GK 101 0A

VARIANTS

OB BT10b & BT10c BOGIES(ONE OF EACH), TARE 39.

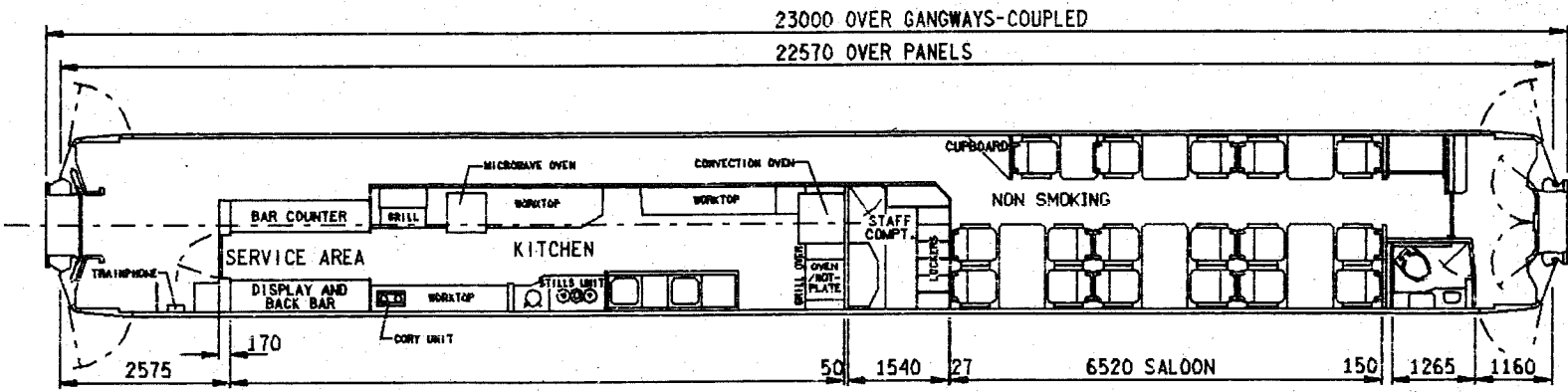
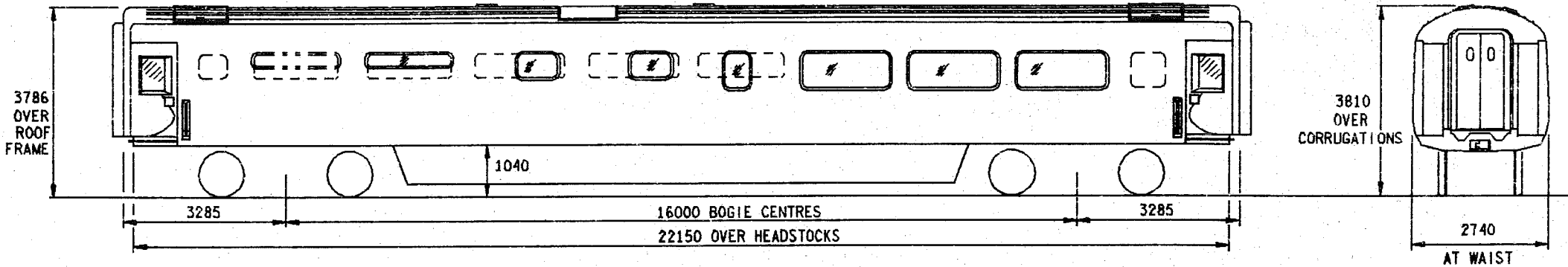

- | | |
|---------------------|------------------------------|
| SEATS | 17 |
| TOILETS | 1 (STAFF) |
| COMPARTMENTS | - |
| GUARDS COMPARTMENTS | - |
| VENTILATION | FULL AIR CONDITIONING |
| CATERING EQUIPMENT | ELECTRIC-MICROWAVE/MICROAIRE |

ISSUE 1 DATE MAR 87

GK 102

BASIC TYPE

ALTERNATIVES

BRAKES
BOGIE/SUSPENSION
BODY CONSTRUCTION
COUPLINGS
TRAIN HEATING
MAX.SPEED M.P.H.
MIN.RAD.CURVE CHAINS
LIGHTING
TARE WEIGHT TONNES
GANGWAYS
TRAIN COMMUNICATION
BUFFERS
SEATS

AIR
BT10 & BT10a(ONE OF EACH)
STEEL
AUTOMATIC SOLID SHANK(ALLIANCE No.2 LONG SHANK)
ELECTRIC(BR) FULL AIR CONDITIONING
125
4.5
FLUORESCENT & TUNGSTEN
39 (EST.)
CENTRALLY SUPPORTED-SWIVELING-FLEXIBLE DIAPHRAGM-STEEL FACE PLATE
PUBLIC ADDRESS & TRANSMITTER
NOT FITTED
INTER-CITY 70

TRACTION DATA FOR MULTIPLE UNITS

HST INTRODUCED-EASTERN REGION 1978,RECLASSIFIED 1985,CONVERTED TO TRFM & DECLASSIFIED 1987.

BASIC TYPE

GK 102 0A

VARIANTS

NONE

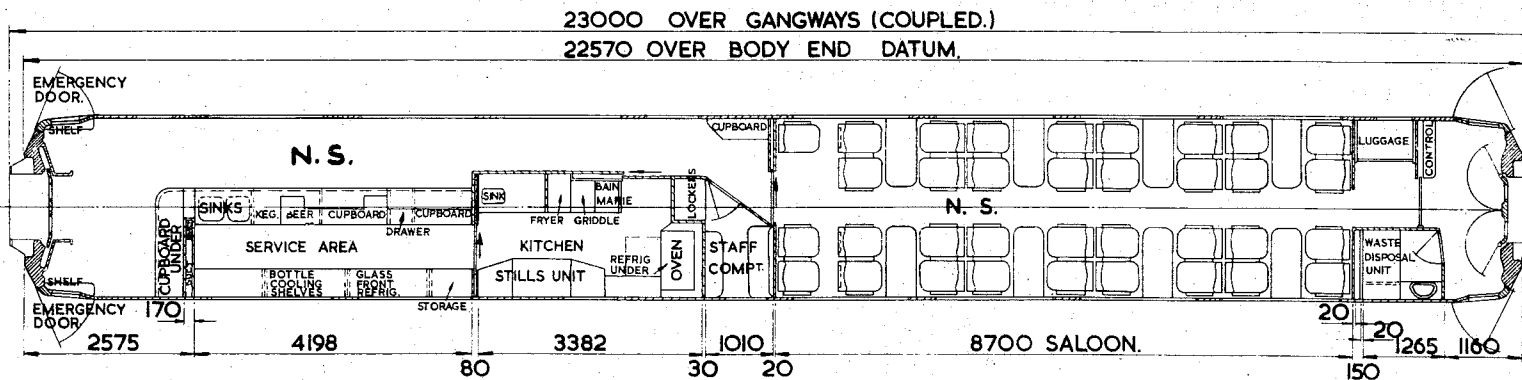
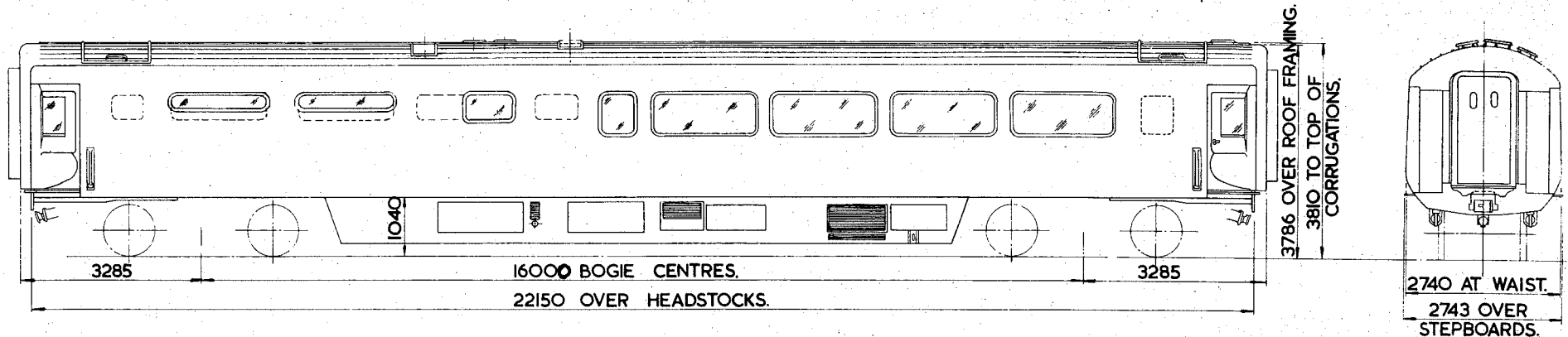

N. S. - NO SMOKING

- SEATS 35
- TOILETS -
- COMPARTMENTS -
- GUARDS COMPARTMENTS -
- VENTILATION FULL AIR CONDITIONING
- CATERING EQUIPMENT ELECTRIC MICROWAVE/MICROAIRE

ORIGINAL DIAGRAMS FOR REFERENCE:-
BR 695

ISSUE 4 DATE MAR 87

GK 202

BASIC TYPE

BRAKES
BOGIE/SUSPENSION
BODY CONSTRUCTION
COUPLINGS
TRAIN HEATING
MAX.SPEED M.P.H.
MIN.RAD.CURVE CHAINS
LIGHTING
TARE WEIGHT TONNES
GANGWAYS

AIR
BT10 & BT10a(ONE OF EACH) 2 LONG SHANK)
STEEL
AUTOMATIC SOLID SHANK(ALLIANCE NO
ELECTRIC(BR)FULL AIR CONDITIONING
125
4.5
FLUORESCENT & TUNGSTEN
36
CENTRALLY SUPPORTED-SWIVELLING-FOAM DIAPHRAGM-STEEL FACE PLATE
PUBLIC ADDRESS WITH TRANSMITTER
NOT FITTED

ALTERNATIVES

CENTRALLY SUPPORTED-SWIVELLING-FLEXIBLE DIAPHRAGM-
STEEL FACE PLATE

TRAIN COMMUNICATION
BUFFERS

TRACTION DATA FOR MULTIPLE UNITS

HST- INTRODUCED-CLASS 253 WESTERN REGION 1976-CLASS 254 EASTERN REGION 1978,DECLASSIFIED 1987.

BASIC TYPE

GK 202 0A

VARIANTS

OB GANGWAYS HAVE FLEXIBLE DIAPHRAGM.

TRAILER RESTAURANT UNCLASSIFIED WITH BUFFET-HST

CLASS ---

TRUB

GK 401

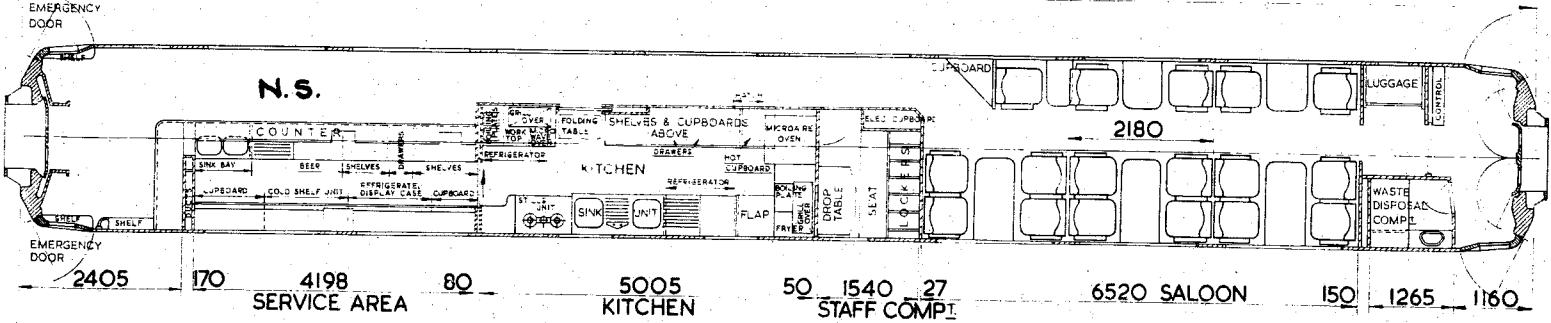
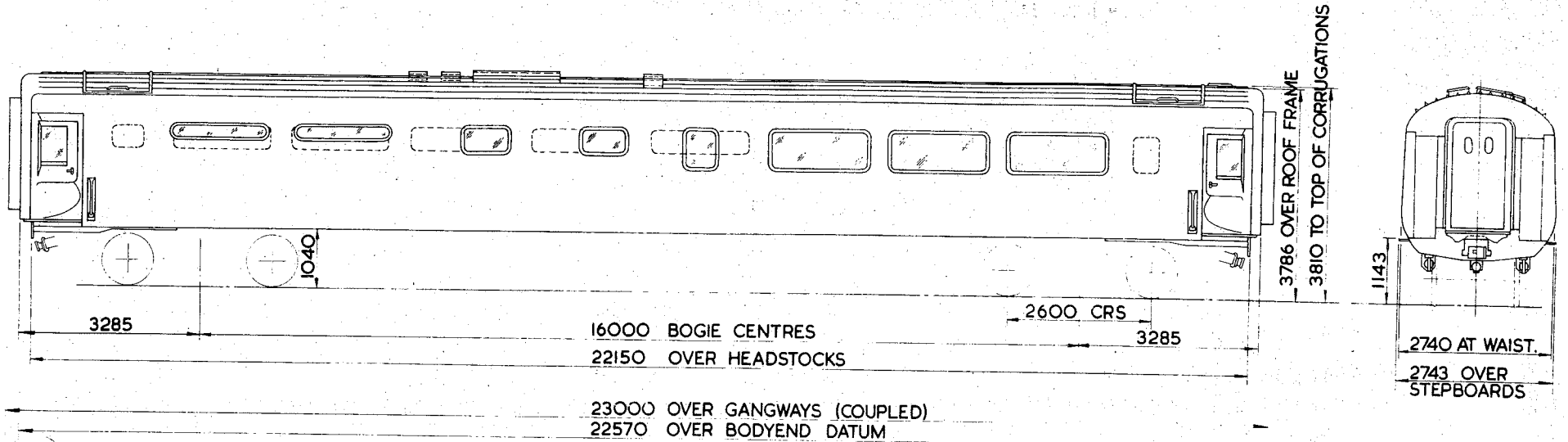

- SEATS
 - TOILETS
 - COMPARTMENTS
 - GUARDS COMPARTMENTS
 - VENTILATION
 - CATERING EQUIPMENT
- 17
-
-
-
- FULL AIR CONDITIONING
- ELECTRIC-MICROWAVE/MICROAIRE

ORIGINAL DIAGRAMS FOR REFERENCE:-
BR 697

ISSUE 5 DATE MAR 87

GK 401

BRAKES
BOGIE/SUSPENSION
BODY CONSTRUCTION
COUPLINGS
TRAIN HEATING
MAX.SPEED M.P.H.
MIN.RAD.CURVE CHAINS
LIGHTING
TARE WEIGHT TONNES
GANGWAYS
TRAIN COMMUNICATION
BUFFERS
SEATS

BASIC TYPE

AIR
BT10 & BT10a(ONE OF EACH)
STEEL
AUTOMATIC SOLID SHANK(ALLIANCE No. LONG SHANK)
ELECTRIC(BR) FULL AIR CONDITIONING
125
4.5
FLUORESCENT & TUNGSTEN
39
CENTRALLY SUPPORTED-SWIVELING-FLEXIBLE DIAPHRAGM-STEEL FACE PLATE
PUBLIC ADDRESS & TRANSMITTER
NOT FITTED
INTER-CITY 70

ALTERNATIVES

BT10b & BT10c(ONE OF EACH)

39

A.P.T.

TRACTION DATA FOR MULTIPLE UNITS

HST INTRODUCED-CLASS 253 WESTERN REGION 1976-WEST OF ENGLAND 1979-NORTHEAST/SOUTHWEST INTRODUCED 1981- CLASS 254 EASTERN REGION 1978.
DECLASSIFIED 1987.

BASIC TYPE

GK 401 0A

VARIANTS

0B BT10b & BT10c BOGIES(ONE OF EACH),TARE 39.
0C BT10b & BT10c BOGIES(ONE OF EACH),TARE 39,A.P.T.SEATS.

TRAILER RESTAURANT FIRST WITH KITCHEN-HST

CLASS ---

TRFK

GL 101

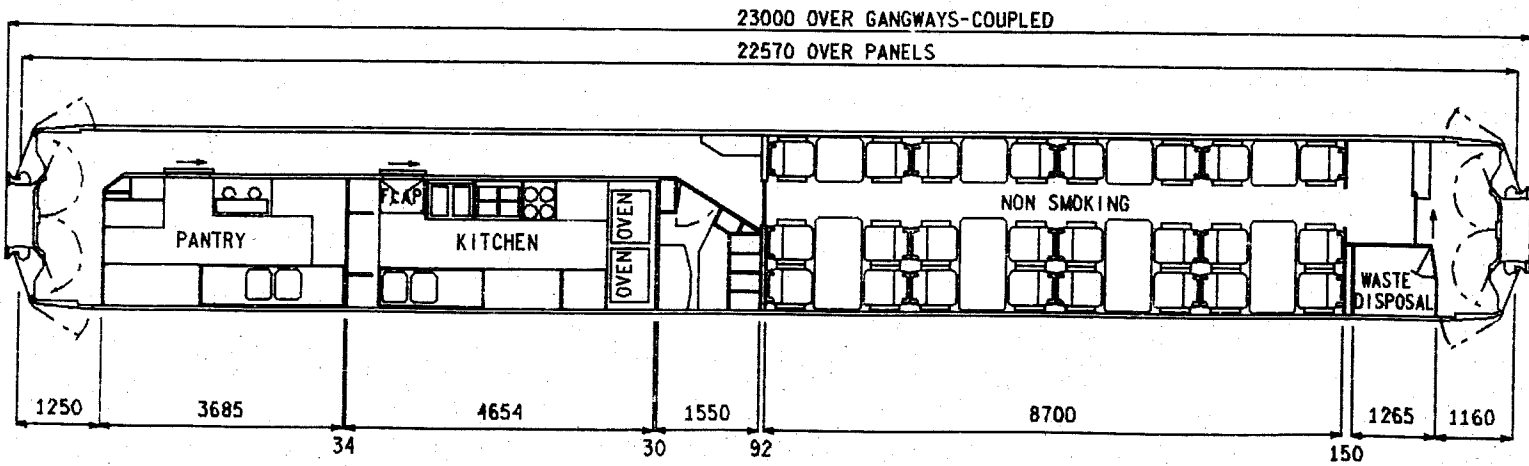
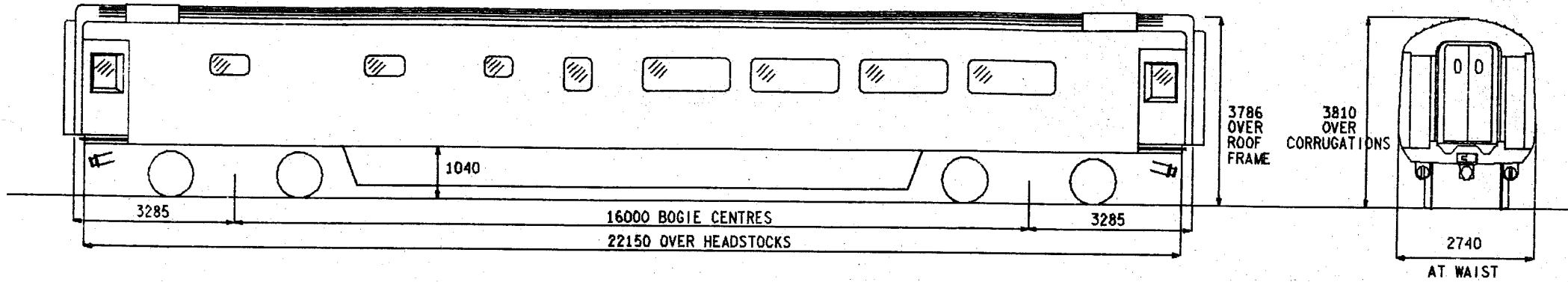

SEATS
TOILETS
COMPARTMENTS
GUARDS COMPARTMENTS
VENTILATION
CATERING EQUIPMENT

24
-
-
-
FULL AIR CONDITIONING
ELECTRIC-MICROWAVE/MICROAIRE

ORIGINAL DIAGRAMS FOR REFERENCE:-
BR 696

ISSUE DATE
2 MAR 87

GL 101

BRAKES
BOGIE/SUSPENSION
BODY CONSTRUCTION
COUPLINGS
TRAIN HEATING
MAX.SPEED M.P.H.
MIN.RAD.CURVE CHAINS
LIGHTING
TARE WEIGHT TONNES
GANGWAYS
TRAIN COMMUNICATION
BUFFERS
SEATS

BASIC TYPE

AIR
BT10 & BT10a(ONE OF EACH)
STEEL
AUTOMATIC SOLID SHANK(ALLIANCE NO.2-LONG SHANK)
ELECTRIC(BR)FULL AIR CONDITIONING
125
4.5
FLUORESCENT & TUNGSTEN
37
CENTRALLY SUPPORTED-SWIVELLING-FLEXIBLE DIAPHRAGM-STEEL FACE PLATE
PUBLIC ADDRESS
NOT FITTED
IC 80

ALTERNATIVES

TRACTION DATA FOR MULTIPLE UNITS

HST- INTRODUCED 1978, DECLASSIFIED 1987.

BASIC TYPE

GL 101 0A

VARIANTS

NONE

TRAILER RESTAURANT UNCLASSIFIED WITH KITCHEN-HST

CLASS ---

TRUK

GL 402

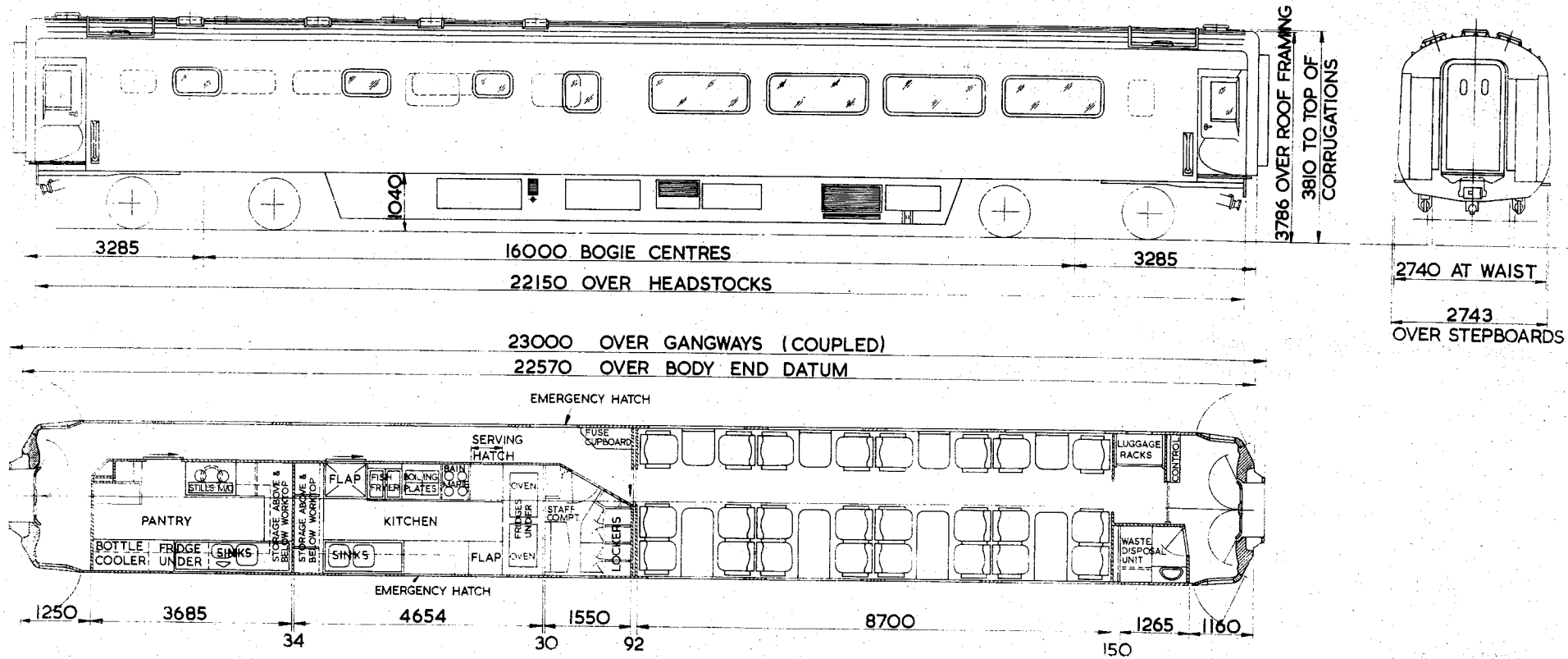

- SEATS 24
- TOILETS -
- COMPARTMENTS -
- GUARDS COMPARTMENTS -
- VENTILATION FULL AIR CONDITIONING
- CATERING EQUIPMENT ELECTRIC-MICROWAVE/MICROAIRE

ORIGINAL DIAGRAMS FOR REFERENCE:-
BR 696

ISSUE 3 DATE MAR 87

GL 402

BRAKES
BOGIE/SUSPENSION
BODY CONSTRUCTION
COUPLINGS
TRAIN HEATING
MAX. SPEED M.P.H.
MIN. RAD. CURVE CHAINS
LIGHTING
TARE WEIGHT TONNES
GANGWAYS
TRAIN COMMUNICATION
BUFFERS

BASIC TYPE

AIR
BT10 & BT10a(ONE OF EACH)
STEEL
AUTOMATIC SOLID SHANK(ALLIANCE No.2 LONG SHANK)
ELECTRIC(BR)FULL AIR CONDITIONING
125
4.5
FLUORESCENT & TUNGSTEN
37
CENTRALLY SUPPORTED-SWIVELLING-FLEXIBLE DIAPHRAGM-STEEL FACE PLATE
PUBLIC ADDRESS
NOT FITTED

ALTERNATIVES

TRACTION DATA FOR MULTIPLE UNITS

HST- INTRODUCED 1978, DECLASSIFIED 1987.

BASIC TYPE

GL 402 DA

VARIANTS

NONE

TRAILER LOUNGE UNCLASSIFIED WITH KITCHEN-HST

CLASS ---

TLUK

GM 401

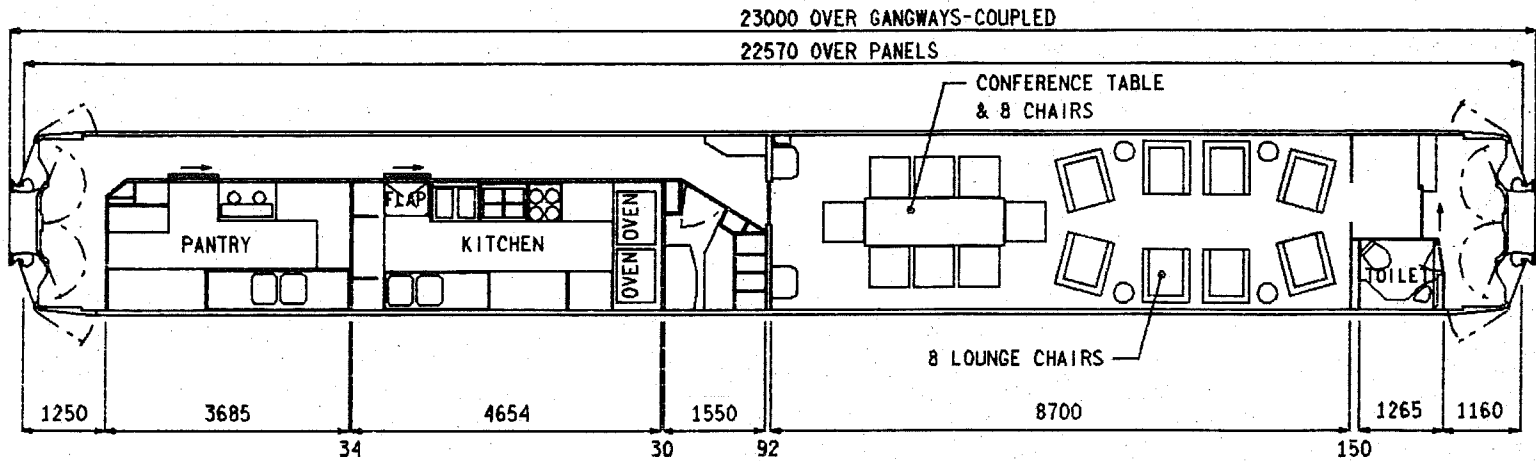
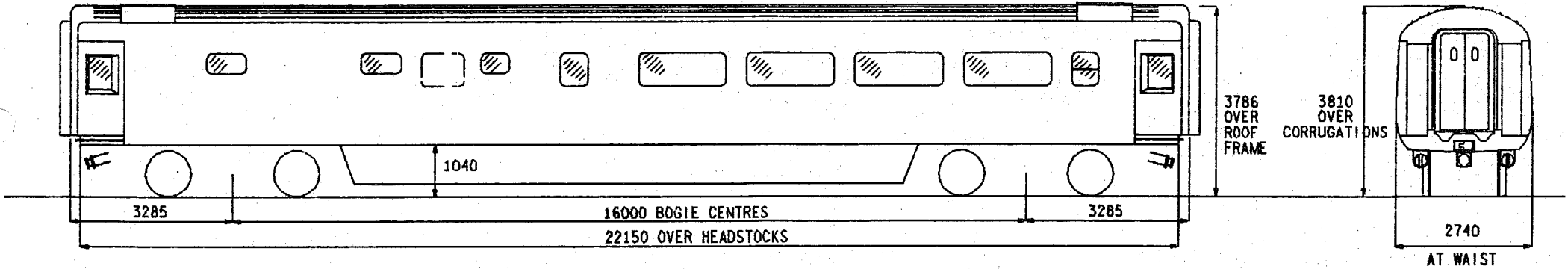

SEATS
TOILETS
COMPARTMENTS
GUARDS COMPARTMENTS
VENTILATION
CATERING EQUIPMENT

16
1
-
-
FULL AIR CONDITIONING
ELECTRIC-MICROWAVE/MICROAIRE

ISSUE 2
DATE MAR 87

GM 401

BRAKES
BOGIE/SUSPENSION
BODY CONSTRUCTION
COUPLINGS
TRAIN HEATING
MAX.SPEED M.P.H.
MIN.RAD.CURVE CHAINS
LIGHTING
TARE WEIGHT TONNES
GANGWAYS
TRAIN COMMUNICATION
BUFFERS

BASIC TYPE

AIR
BT10 & BT10a(ONE OF EACH)
STEEL
AUTOMATIC SOLID SHANK(ALLIANCE NO.2-LONG SHANK)
ELECTRIC(BR)FULL AIR CONDITIONING
125
4.5
FLUORESCENT & TUNGSTEN
36.5 (ESTIMATED)
CENTRALLY SUPPORTED-SWIVELLING-FLEXIBLE DIAPHRAGM-STEEL FACE PLATE
PUBLIC ADDRESS
NOT FITTED

ALTERNATIVES

TRACTION DATA FOR MULTIPLE UNITS

HST- INTRODUCED 1978,-MODIFIED TO LOUNGE CAR 1984,DECLASSIFIED 1987.

BASIC TYPE

GM 401 OA

VARIANTS

NONE

TRAILER RESTAURANT WITH BUFFET-HST

CLASS ---

TRB

GN 401

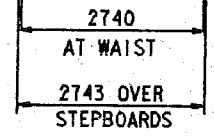
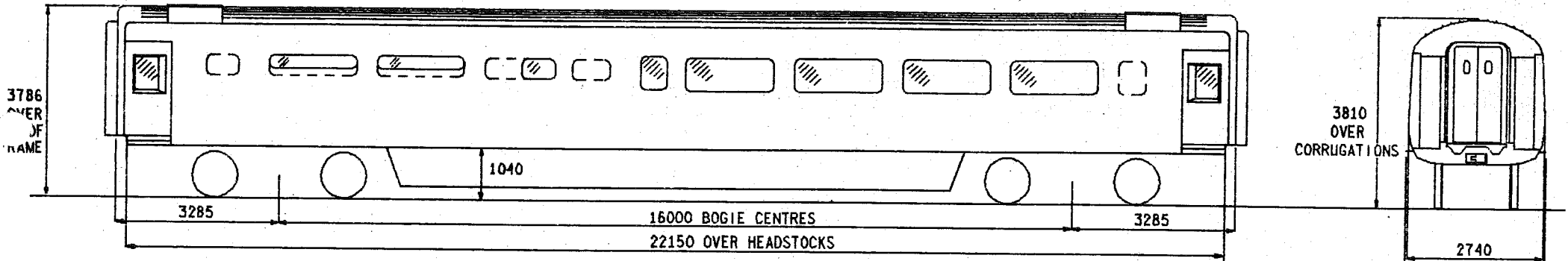

23000 OVER GANGWAYS-COUPLED

22570 OVER PANELS

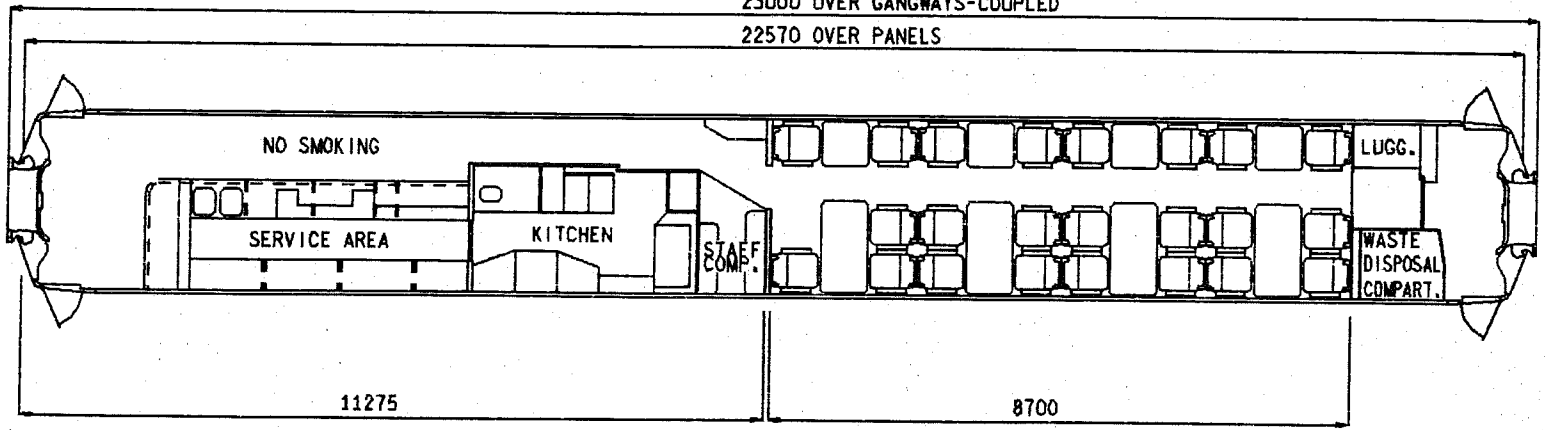

- SEATS 23
- TOILETS -
- COMPARTMENTS -
- GUARDS COMPARTMENTS -
- VENTILATION FULL AIR CONDITIONING
- CATERING EQUIPMENT ELECTRIC-MICROWAVE/MICROAIRE

ISSUE 2 DATE MAR 87

GN 401

BRAKES
BOGIE/SUSPENSION
BODY CONSTRUCTION
COUPLINGS
TRAIN HEATING
MAX.SPEED M.P.H.
MIN.RAD.CURVE CHAINS
LIGHTING
TARE WEIGHT TONNES
GANGWAYS
TRAIN COMMUNICATION
BUFFERS

BASIC TYPE

AIR
BT10 & BT10a(ONE OF EACH)
STEEL
AUTOMATIC SOLID SHANK (ALLIANCE No 2 LONG SHANK)
ELECTRIC(BR)FULL AIR CONDITIONING
125
4.5
FLUORESCENT & TUNGSTEN
36 (ESTIMATED)
CENTRALLY SUPPORTED-SWIVELLING-FLEXIBLE DIAPHRAGM-STEEL FACE PLATE
PUBLIC ADDRESS WITH TRANSMITTER
NOT FITTED

ALTERNATIVES

TRACTION DATA FOR MULTIPLE UNITS

HST-

INTRODUCED 1978,-MODIFIED TO TRAILER RESTAURANT BUFFET 1985,DECLASSIFIED 1987.

BASIC TYPE

GN 401 0A

VARIANTS

NONE