British Railways Board

Mechanical & Electrical Engineering Department

VEHICLE DIAGRAM BOOK NO 200

FOR

Loco Hauled Coaches

© COPYRIGHT NOTICE

This PDF file has been created from the original book with permission of BRB Residuary Ltd who, retain copyright in the original document.

The original book was provided courtesy of Eddie Knorr.

This PDF version by David Faulkner, 2011.

Individuals may: use, retain and print out this PDF version for their private information or for that of their non-commercial enthusiast society or railway club.

This document and any copies produced from it in any form may not be sold or lent for any payment in any form other than to cover copying or transmission costs. No reproduction permitted in any other form or circumstance without prior permission from the original copyright holder



Contained in this book:

Design Code	Mark	Vehicle Type	ex Diag	Issue	Date
AA101	Mk I	FK	116	4	Oct ' 86
AA104	Mk 2	FK	120	1	Sep ' 80
AA105	Mk II	FK	122	4	Apr ' 98
AA106	Mk IIA	FK	123	2	Oct ' 81
AA107	Mk IIB	FK	124	2	Oct ' 81
AA108	Mk IIC	FK	125	3	Dec ' 81
AA109	Mk IID	FK	129	2	Oct ' 81
AA201	Mk I	SK	146	5	Dec ' 86
AA202	Mk I	SK	147	4	Oct ' 86
AA204	Mk I	SK	150	1	Sep ' 80
AA207	Mk IIB	SK	(124)	1	Oct ' 86
AA208	Mk IIC	SK	(125)	1	Oct ' 86
AA209	Mk IIA	SK	(123)	1	Oct ' 86
AA301	Mk I	CK	126	3	Oct ' 86
AA301	Mk I	CK	126	4	Mar ' 89
AA302	Mk I	CK	128	6	Mar ' 87
AA302	Mk I	CK	128	7	Mar ' 89
AA303	Mk II	CK	(122)	3	Mar ' 88
AA304	Mk IIC	CK	(125)	2	Oct ' 86
AB101	Mk I	BFK	161	6	Mar ' 87
AB102	Mk II	BFK	162	4	Nov ' 87
AB103	Mk IIA	BFK	163	3	Jul ' 88
AB104	Mk IIB	BFK	164	1	Sep ' 80
AB105	Mk IIC	BFK	165	2	Oct ' 81
AB106	Mk IID	BFK	166	4	Mar ' 87
AB201	Mk I	BSK	181	5	Dec ' 88
AB201	Mk I	BSK	181	6	Mar ' 89
AB202	Mk I	BSK	182	5	Oct ' 86
AB203	Mk I	BSK		2	Aug ' 82
AB204	Mk II	BSK		3	Apr ' 87
AB301	Mk I	BCK	171	2	Nov ' 87
AB302	Mk I	BCK	172A	5	Mar ' 87
AC201	Mk I	TSO	89	7	Dec ' 88
AC201	Mk I	TSO	89	8	Dec ' 88
AC204	Mk I	TSO	93	4	Oct ' 86
AC205	Mk II	TSO	88	5	Apr ' 88
AC206	Mk IIA	TSO	86	3	Apr ' 88
AC207	Mk IIB	TSO	105	2	Oct ' 86
AC208	Mk IIC	TSO	106	2	Oct ' 86

Design Code	Mark	Vehicle Type	ex Diag	Issue	Date
AC209	Mk IID	TSO	107	3	Dec ' 88
AC210	Mk IIE	TSO	108	2	Dec ' 86
AC211	Mk IIF	TSO	109	6	Oct ' 86
AC212	Mk IIIA	TSO	111	3	Apr ' 87
AC213	Mk IIIA	TSO		2	Oct ' 88
AC215	Mk IIF	TSO	(109)	1	Jul ' 89
AC216	Mk IIIA	TSO		1	Jul ' 89
AC217	Mk IID	TSO		1	Not Issued, 5 Sheets
AC218	Mk IIF	TSO	(109)	1	Jul ' 89
AC219	Mk IIIA	TSO		1	Jul ' 89
AC220	Mk IIIA	TSO		1	Jul ' 89
AC221	Mk IIIA	TSO		1	Jul ' 89
AC222	Mk IIIA	TSO	(111)	1	Jul ' 89
AC223	Mk IIIA	TSO	(111)	1	Jul ' 89
AD103	Mk I	FO	73	7	Nov ' 87
AD103	Mk I	FO	73	8	May 89
AD104	Mk IIC	FO	80	4	Dec ' 85
AD105	Mk IID	FO	81	2	Oct ' 81
AD106	Mk IIE	FO	82	3	Oct ' 86
AD107	Mk IIF	FO	83	2	Oct ' 86
AD108	Mk IIIA	FO	69	4	Apr ' 87
AD110	Mk IIIB	FO		3	Jan ' 88
AD201	Mk I	SO	94	2	Oct ' 86
AD203	Mk II	SO	87	1	Sep ' 80
AD204	Mk I	SO	73	2	May 81
AD205	Mk IIC	SO		2	Apr ' 83
AD206	Mk IIF	SO	(83)	2	Jul ' 87
AD301	Mk IIIA	TC (!)		1	Jun ' 86
AE101	Mk IIIB	BFO		3	Apr ' 89
AE201	Mk I	BSO	183	2	May 81
AE202	Mk I	BSO	184	1	Sep ' 80
AE203	Mk II	BSO	185	5	Apr ' 88
AE204	Mk IIA	BSO	180	2	Apr ' 88
AE205	Mk IIC	BSO	186	2	Dec ' 86
AE206	Mk IID	BSO	187	3	Mar ' 87
AE207	Mk IIE	BSO	188	4	Mar ' 87
AE208	Mk IIF	BSO	189	4	Mar ' 87
AF201	Mk IIF	DBSO	190	4	Jun ' 85
AG201	Mk IIC	TSOT		2	Apr ' 88

Design Code	Mark	Vehicle Type	ex Diag	Issue	Date
AG202	Mk IID	TSOT		1	May 84
AH202	Mk I	BSOT		1	May 84
AH203	Mk II	BSOT		2	May 86
AH203	Mk II	BSOT		3	Mar ' 88
AH204	Mk II	BSOT		2	Mar ' 88
AJ102	Mk III	RFB	43	2	Dec ' 85
AJ103	Mk III	RFM		1	Jul ' 87
AJ104	Mk IIF	RFO		1	Jul ' 88
AJ104	Mk IIF	RFO		1	Jul ' 88
AJ104	Mk IIF	RFO		2	Mar ' 89
AJ403	Mk I	RBR	33	6	Dec ' 85
AJ404	Mk I	RBK	26	2	May 81
AJ408	Mk I	RBR		1	Sep ' 80
AJ414	Mk I	RBR		2	May 81
AJ415	Mk I	RBR		1	Sep ' 80
AK502	Mk I	RKB	25	1	May 84
AM201	Mk I	RSO	73	2	May 81
AN101	Mk IIF	RLO		1	Apr ' 87
AN101	Mk IIF	RLO		1	Apr ' 87
AN101	Mk IIF	RLO		2	Mar ' 89
AN102	Mk IIF	RLO		1	Mar ' 89
AN202	Mk I	RMB	98	5	Oct ' 86
AN203	Mk I	RMB	99	6	Oct ' 86
AN207	Mk IID	RMBT		1	Mar ' 86
AN208	Mk I	RMB		2	Aug ' 88
AP101		PFK	15	2	Oct ' 86
AQ101		PFP	78	2	Oct ' 86
AR101		PFB	85	1	Sep ' 80
AS101	Mk I	SLF	1	1	Sep ' 80
AS201	Mk I	SLS	10	3	Aug ' 82
AS301	Mk I	SLC	5	4	Dec ' 85
AS401	Mk I	SLE	14	2	Dec ' 81
AS402	Mk I	SLE	10	2	May 81
AS404	Mk IIIA	SLE	6	3	Apr ' 87
AU401	Mk IIIA	SLEP	7	2	Apr ' 87
AU501	Mk I	SLSC		1	Oct ' 88
AX201		S	WR C48	1	Sep ' 80
AX202		S	WR C78	1	Sep ' 80
AX203		S		1	Jan ' 84
AY201		BS	WR D128	1	Sep ' 80
AY202		BS	WR K43	1	Sep ' 80

Design Code	Mark	Vehicle Type	ex Diag	Issue	Date
AY301		BC	WR D128	1	Jan ' 84
GH203	Mk III	TS		5	Mar ' 87
GK202	Mk III	TRSB	695	4	Mar ' 87
NS501	Mk I	POS	720	1	Sep ' 80
NS502	Mk I	POS	721	1	Sep ' 80
NS503	Mk I	POS	726A	1	Sep ' 80
NS504	Mk I	POS	728	2	May 81
NS505	Mk I	POS	729	2	May 81
NS506	Mk I	POS	731	2	May 81
NS531	Mk I	POS	726A	1	Sep ' 80
NT501	Mk I	POT	724B	1	Sep ' 80
NT502	Mk I	POT	722	1	Sep ' 80
NT503	Mk I	POT	725A	1	Sep ' 80
NT504	Mk I	POT	727A	1	Sep ' 80
NT505	Mk I	POT	732	1	Sep ' 80
NT521	Mk I	POT	727A	1	Sep ' 80
NU501	Mk I	POTB	723	1	Sep ' 80
NU502	Mk I	POTB	733	1	Sep ' 80
YX068		Side loading Motorail Vehicle		1	2/91

MISC DRAWINGS

- Mk IID FO to TSO Conversion drawing
- Mk IID FO to TSO Conversion drawing
- Mk IID Livery diagram
- draft Mk IID TSO
- Mark 4 Drawings

PREFACE

A complete list of Vehicle Diagram Books is shown below, together with new or revised book reference numbers & the colours of the respective book covers. The existing Diagram books covering Locomotives and Rail Crane vehicles which were previously shown with MT/reference numbers, have now received new covers in accordance with this revised numbering system.

REVISED VEHICLE DIAGRAM BOOK NUMBERS

Vehicle Type	Diagram Book No	Colour of Cover	Vehicle Type	Diagram Book No	Colour of Cover
<u>Locomotives:- Diagram Book Series 100</u>			<u>Freight Vehicles:- Diagram Book Series 300</u>		
Diesel Electric Main Line Locos	100 (Previously No MT/25)	Red	Privately Owned Freight Vehicles	300	White
Electric Main Line Locos	110 (Previously No MT/26)	Green	Privately Owned International Ferry Vehicle	310	White
Diesel Shunting Locos	120 (Previously No MT/27)	Yellow	BR Revenue Freight Vehicle	320	Buff
<u>Coaching & Multiple Unit Stock:- Diagram Book Series 200</u>			BR International Ferry Vehicles	330	Buff
Loco Hauled Coaches	200	Orange	Foreign Administration Freight Vehicles	340	White
Electric Multiple Units	210	Blue	BR Service Department Vehicles	350	Buff
Diesel Multiple Units (Railcar)	220	Pink			
Diesel Electric Multiple Units (HST)	230	Pink			
			<u>ON Track Plant:- Diagram Book Series 400</u>		
			Rail Cranes & Tracklaying Vehicles	400 (Previously No MT/212)	Red

JULY 1982

Issued by:-

Director of Mechanical & Electrical Engineering
Railway Technical Centre
DERBY

VEHICLE DIAGRAM BOOK NO 200

FOR

Loco Hauled Coaches

SUMMARY OF CONTENTS

NOTE:- The contents of this book are arranged in alphabetical order, according to vehicle DESIGN CODE.

AA	First Corridor	AM	Restaurant Second Open
AA	Second Corridor	AN	Restaurant Miniature Buffet
AA	Composite Corridor	AP	Pullman First with Kitchen
AB	Brake First Corridor	AQ	Pullman First Parlour
AB	Brake Second Corridor	AR	Pullman First Brake
AB	Brake Composite Corridor	AS	Sleeping First
AC	Second Open 2 x 2 Seating	AS	Sleeping Second
AD	First Open	AS	Sleeping Composite
AD	Second Open 2 x 1 Seating	AS	Sleeping Either Class
AE	Brake First Open	AT	Special Vehicles
AE	Brake Second Open	AU	Sleeping Either Class with Pantry
AF	Driving Brake Second Open	AX	Second - Narrow Gauge - Open
AG	Second Open with Micro Buffet	AY	Brake Second - Narrow Gauge - Open
AH	Brake Second Open with Micro Buffet	AY	Brake Composite - Narrow Gauge - Open
AJ	Restaurant First Buffet with Kitchen	NS	Post Office Sorting Van
AJ	Restaurant Second Modular	NU	Postal Brake Van
AJ	Restaurant Buffet with Kitchen - Unclassed	NT	Post Office Stowage Van
AK	Restaurant Buffet Kitchen		

FIRST CORRIDOR-MK 1

CLASS ---

FK

AA 101

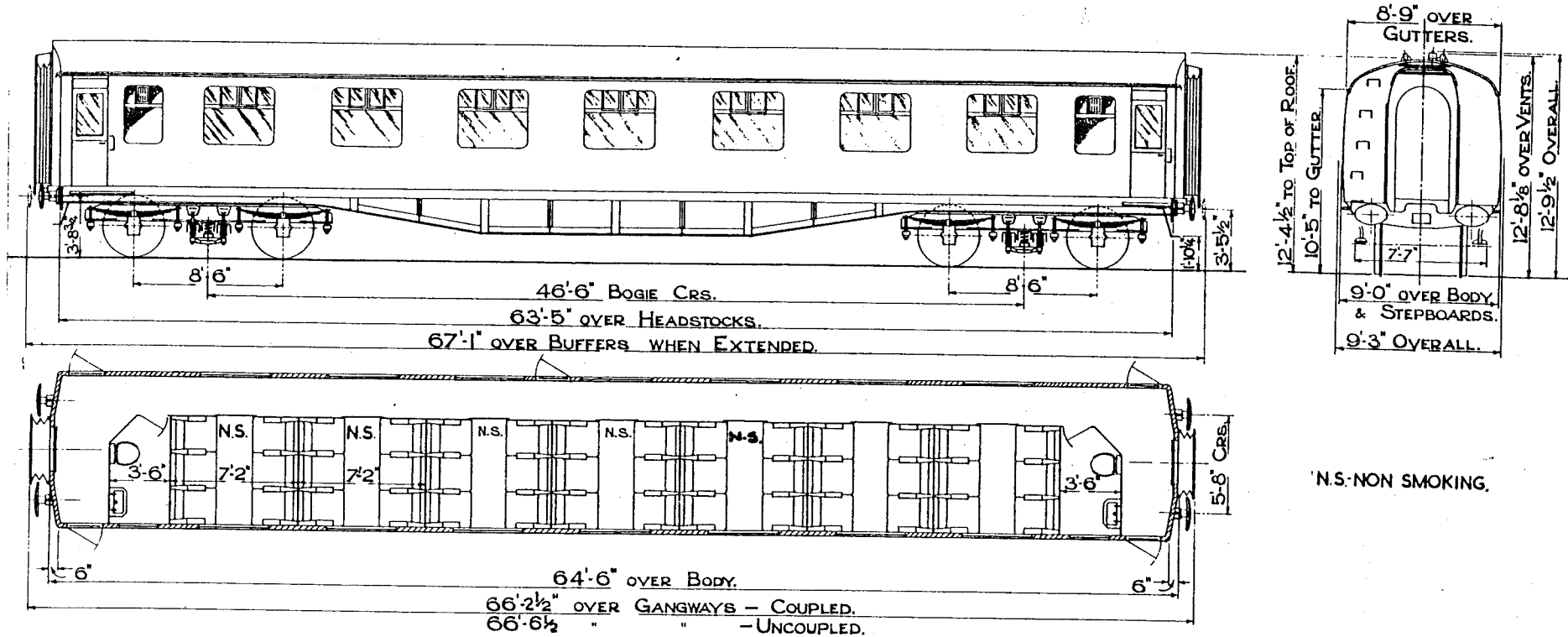

N.S.-NON SMOKING.

SEATS	42
TOILETS	2
COMPARTMENTS	7
GUARDS COMPARTMENTS	-
VENTILATION	-
CATERING EQUIPMENT	-

ORIGINAL DIAGRAMS FOR REFERENCE:-
BR 116

ISSUE 4
DATE OCT '86

AA 101

	<u>BASIC TYPE</u>	<u>ALTERNATIVES</u>
BRAKES	VACUUM	VACUUM & AIR, AIR
BOGIE/SUSPENSION	COMMONWEALTH	B4, BR MK 1 LIGHT, DOUBLE BOLSTER
BODY CONSTRUCTION	STEEL	
COUPLINGS	AUTOMATIC DROPHEAD(BUCKEYE)	
TRAIN HEATING	STEAM	DUAL(STEAM/ELECTRIC(BR)), ELECTRIC(BR)
E.T.H. INDEX	-	3
MAX.SPEED M.P.H.	100	90
MIN.RAD.CURVE CHAINS	3.5	
LIGHTING	TUNGSTEN	FLUORESCENT & TUNGSTEN
TARE WEIGHT TONNES	34	
GANGWAYS	PULLMAN	FITTED
TRAIN COMMUNICATION	NOT FITTED	
BUFFERS	RETRACTABLE SPINDLE(559X356 OVAL)	COMPOSITION
BRAKE BLOCKS	CAST IRON	

TRACTION DATA FOR MULTIPLE UNITSBASIC TYPE

AA 101 OA

VARIANTS

- OC BR MK 1 LIGHT DOUBLE BOLSTER BOGIES, MAX.SPEED 90.
- OF B4 BOGIES, COMPOSITION BRAKE BLOCKS.
- 1A DUAL HEATING(STEAM/ELECTRIC(BR)), E.T.H.3.
- 1B DUAL HEATING(STEAM/ELECTRIC(BR)), E.T.H.3, B4 BOGIES.
- 1C DUAL HEATING(STEAM/ELECTRIC(BR)), E.T.H.3, BR MK 1 LIGHT DOUBLE BOLSTER BOGIES, MAX.SPEED 90.
- 1D DUAL HEATING(STEAM/ELECTRIC(BR)), E.T.H.3, B4 BOGIES, VACUUM & AIR BRAKES.
- 1E DUAL HEATING(STEAM/ELECTRIC(BR)), E.T.H.3, BR MK 1 LIGHT DOUBLE BOLSTER BOGIES, VACUUM & AIR BRAKES, MAX SPEED 90.
- 1F DUAL HEATING(STEAM/ELECTRIC(BR)), E.T.H.3, B4 BOGIES, COMPOSITION BRAKE BLOCKS.
- 1G DUAL HEATING(STEAM/ELECTRIC(BR)), E.T.H.3, COMPOSITION BRAKE BLOCKS.
- 2A DUAL HEATING(STEAM/ELECTRIC(BR)), E.T.H.3, FLUORESCENT & TUNGSTEN,
- 2G DUAL HEATING(STEAM/ELECTRIC(BR)), E.T.H.3, FLUORESCENT & TUNGSTEN, COMPOSITION BRAKE BLOCKS.
- 3F ELECTRIC(BR) HEATING, E.T.H.3, B4 BOGIES, COMPOSITION BRAKE BLOCKS.
- 3G ELECTRIC(BR) HEATING, E.T.H.3, FLUORESCENT & TUNGSTEN.
- 3H ELECTRIC(BR) HEATING, E.T.H.3, B4 BOGIES, VACUUM & AIR BRAKES.
- 4J DUAL HEATING(STEAM/ELECTRIC(BR)), E.T.H.3, AIR BRAKES, P.A. FITTED.

FIRST CORRIDOR-MK II

CLASS ---

FK

AA 104

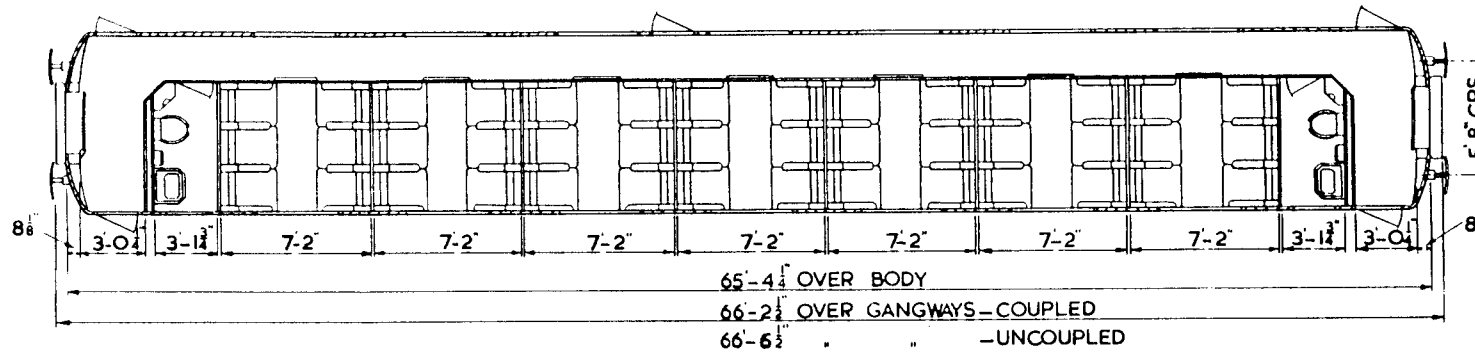
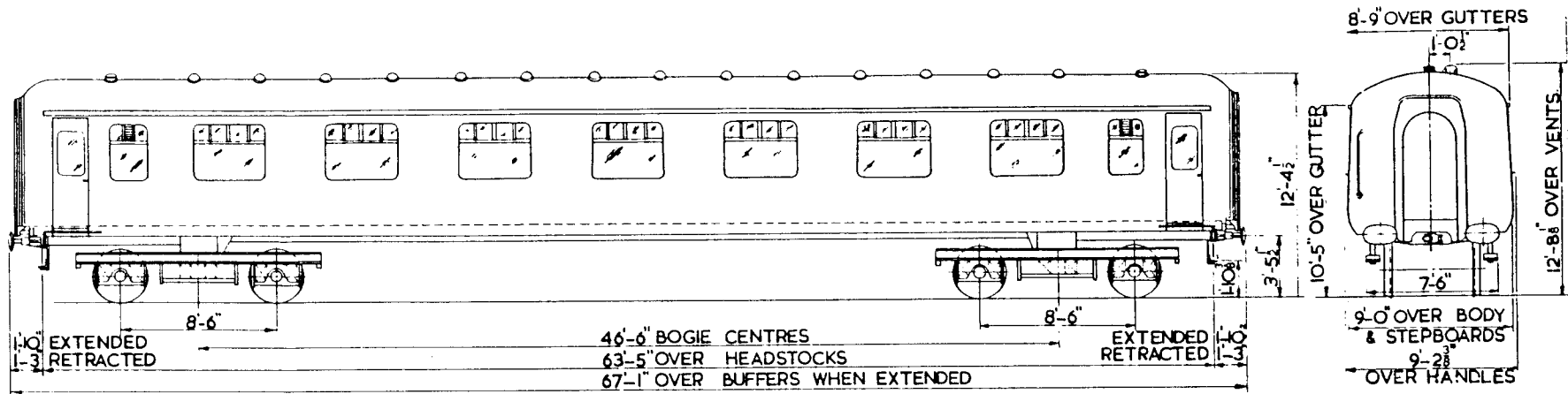

SEATS	42
TOILETS	2
COMPARTMENTS	7
GUARDS COMPARTMENTS	-
VENTILATION	-
CATERING EQUIPMENT	-

ORIGINAL DIAGRAMS FOR REFERENCE -
BR 120

ISSUE 1 DATE SEP '80

AA 104

BASIC TYPE

BRAKES
BOGIE/SUSPENSION
BODY CONSTRUCTION
COUPLINGS
TRAIN HEATING
E.T.H. INDEX
MAX. SPEED M.P.H.
MIN. RAD. CURVE CHAINS
LIGHTING
TARE WEIGHT TONNES
GANGWAYS
TRAIN COMMUNICATION
BUFFERS

VACUUM
B4
STEEL
AUTOMATIC DROPHEAD (BUCKEYE)
STEAM
-
100
3.5
ELECTRIC
30.5
PULLMAN
NOT FITTED
RETRACTABLE SPINDLE (559X356 OVAL)

ALTERNATIVES

TRACTION DATA FOR MULTIPLE UNITS

BASIC TYPE

AA 104 0A

VARIANTS

NONE

FIRST CORRIDOR-MK 11

CLASS ---

FK

AA 105

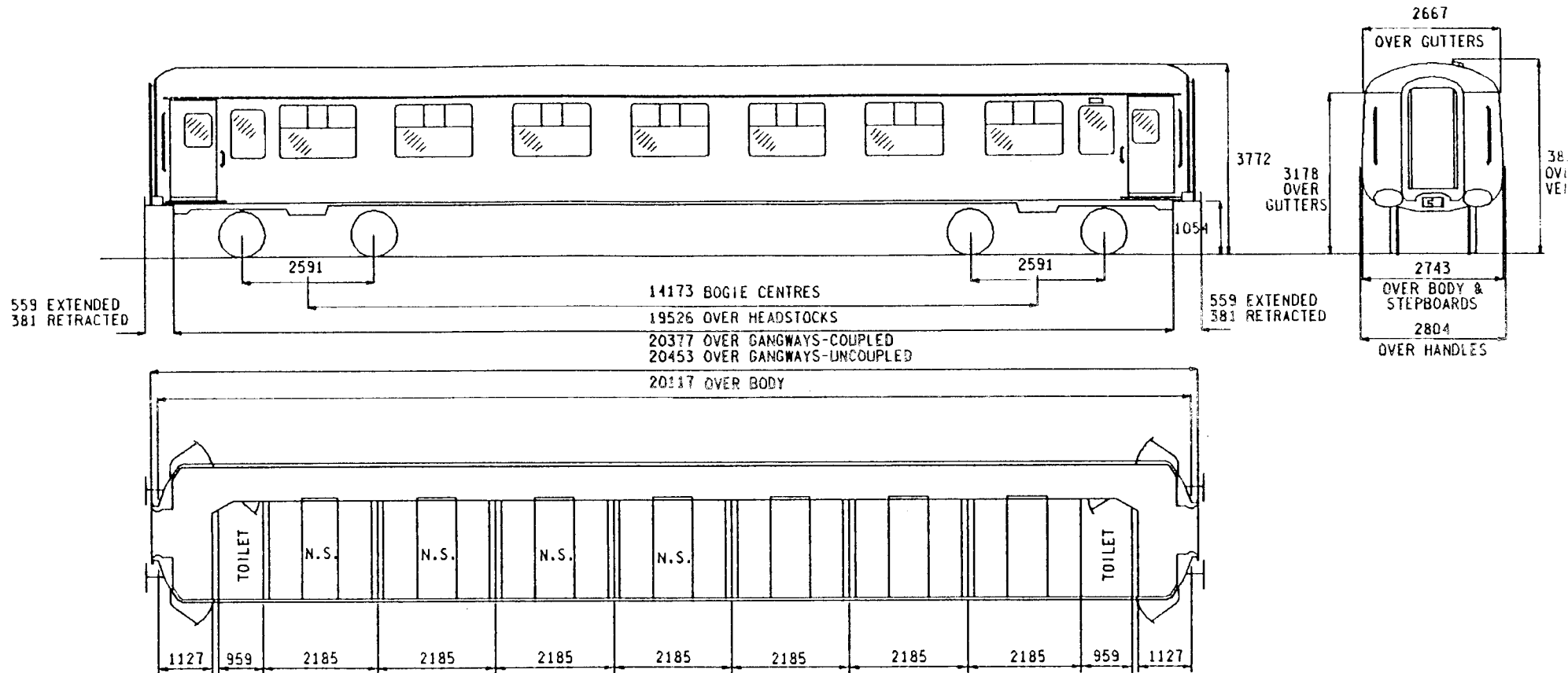

N.S.=NON SMOKING

SEATS	42
TOILETS	2
COMPARTMENTS	7
GUARDS COMPARTMENTS	-
VENTILATION	PRESSURE
CATERING EQUIPMENT	-

ORIGINAL DIAGRAMS FOR REFERENCE:
BR 122

ISSUE 4 DATE APR 98

AA 105

BRAKES
 BOGIE/SUSPENSION
 BODY CONSTRUCTION
 COUPLINGS
 TRAIN HEATING
 E.T.H. INDEX
 MAX.SPEED M.P.H.
 MIN.RAD.CURVE CHAINS
 LIGHTING
 TARE WEIGHT TONNES
 GANGWAYS
 TRAIN COMMUNICATION
 BUFFERS
 BRAKE BLOCKS

BASIC TYPE

VACUUM
 B4
 STEEL
 AUTOMATIC DROPHEAD(BUCKEYE)
 STEAM WITH PRESSURE VENTILATION & HEATING
 -
 100
 3.5
 TUNGSTEN
 35
 PULLMAN
 NOT FITTED
 RETRACTABLE SPINDLE(559X356 OVAL)
 CAST IRON

ALTERNATIVES

AIR

DUAL (STEAM/ELECTRIC(BR)) WITH PRESSURE VENTILATION
 & HEATING, DUAL (STEAM/ELECTRIC(BR)), ELECTRIC(BR).

4

90

FLUORESCENT & TUNGSTEN

FITTED

COMPOSITION

TRACTION DATA FOR MULTIPLE UNITSBASIC TYPE

AA 105 OA

VARIANTS

- 1A FLUORESCENT & TUNGSTEN LIGHTING
 2A DUAL (STEAM/ELECTRIC (BR)) WITH PRESSURE VENTILATION & HEATING, E.T.H.4.
 3A DUAL (STEAM/ELECTRIC (BR)) WITH PRESSURE VENTILATION & HEATING, E.T.H.4, FLUORESCENT & TUNGSTEN LIGHTING.
 3B DUAL (STEAM/ELECTRIC (BR)) WITH PRESSURE VENTILATION & HEATING, E.T.H.4, FLUORESCENT & TUNGSTEN LIGHTING, AIR BRAKES.
 3D DUAL (STEAM/ELECTRIC (BR)) WITH PRESSURE VENTILATION & HEATING, E.T.H.4, FLUORESCENT & TUNGSTEN LIGHTING, COMPOSITION BRAKE BLOCKS.
 4A DUAL HEATING (STEAM/ELECTRIC (BR)), E.T.H.4.
 5B ELECTRIC (BR), AIR BRAKES, E.T.H.4, MAX.SPEED 90.
 5C ELECTRIC (BR), AIR BRAKES, E.T.H.4, MAX.SPEED 90, COMPOSITION BRAKE BLOCKS.
 6B DUAL (STEAM/ELECTRIC (BR)) WITH PRESSURE VENTILATION & HEATING, E.T.H.4, FLUORESCENT & TUNGSTEN LIGHTING, AIR BRAKES, P.A. FITTED.

FIRST CORRIDOR-MK IIA

CLASS ---

FK

AA 106

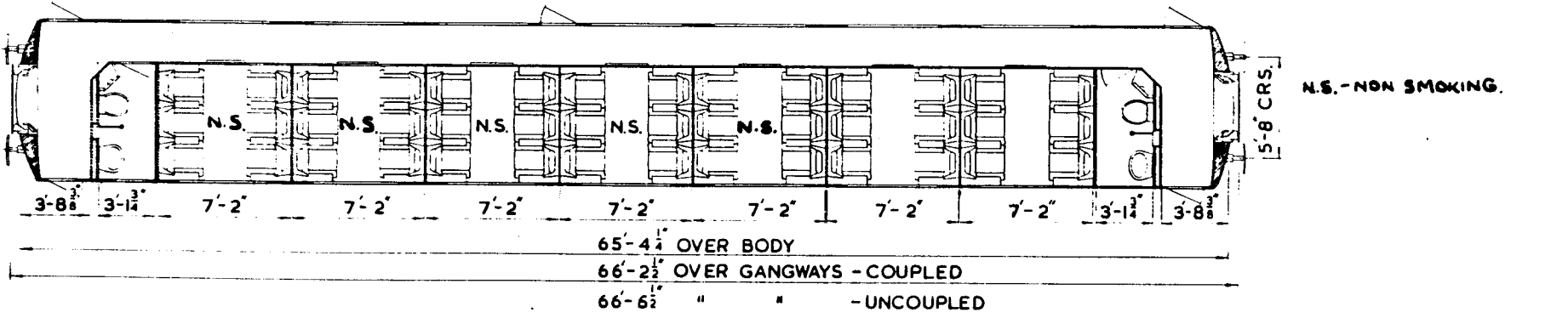
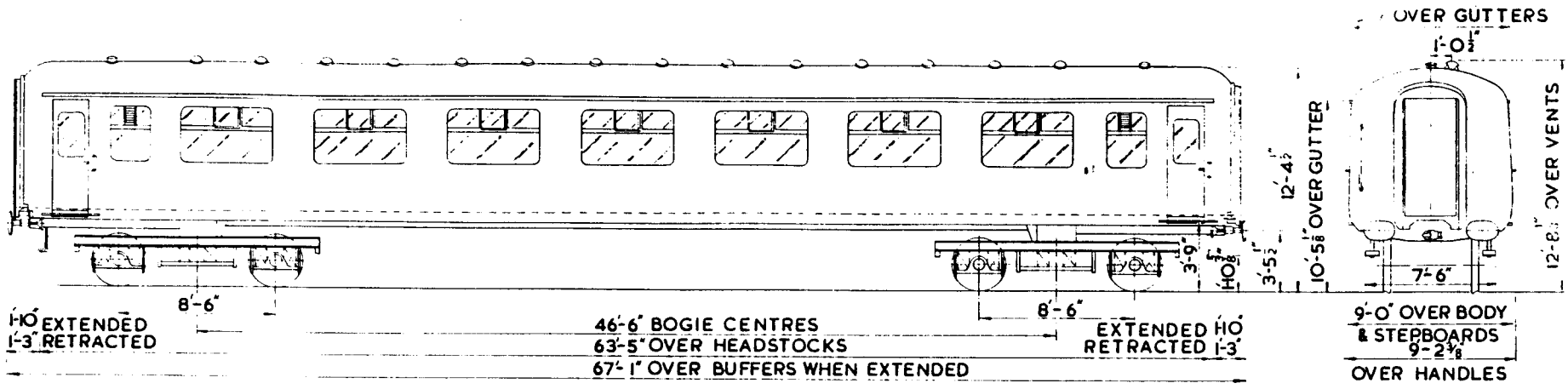

SEATS	42
TOILETS	2
COMPARTMENTS	7
GUARDS COMPARTMENTS	-
VENTILATION	PRESSURE
CATERING EQUIPMENT	-

ORIGINAL DIAGRAMS FOR REFERENCE.-
BR 123

ISSUE 2 DATE OCT '81

AA 106

BASIC TYPE

ALTERNATIVES

BRAKES
BOGIE/SUSPENSION
BODY CONSTRUCTION
COUPLINGS
TRAIN HEATING
E.T.H. INDEX
MAX. SPEED M.P.H.
MIN. RAD. CURVE CHAINS
LIGHTING
TARE WEIGHT TONNES
GANGWAYS
TRAIN COMMUNICATION
BUFFERS

AIR
B4
STEEL
AUTOMATIC DROPHEAD (BUCKEYE)
DUAL (STEAM/ELECTRIC (BR)) WITH PRESSURE VENTILATION & HEATING
4
100
3.5
FLUORESCENT & TUNGSTEN
32
PULLMAN
NOT FITTED
RETRACTABLE SPINDLE (559X356 OVAL)

VACUUM

TRACTION DATA FOR MULTIPLE UNITS

BASIC TYPE

AA 106 0A

VARIANTS

08 VACUUM BRAKES.

FIRST CORRIDOR-MK IIB

CLASS ---

FK

AA 107

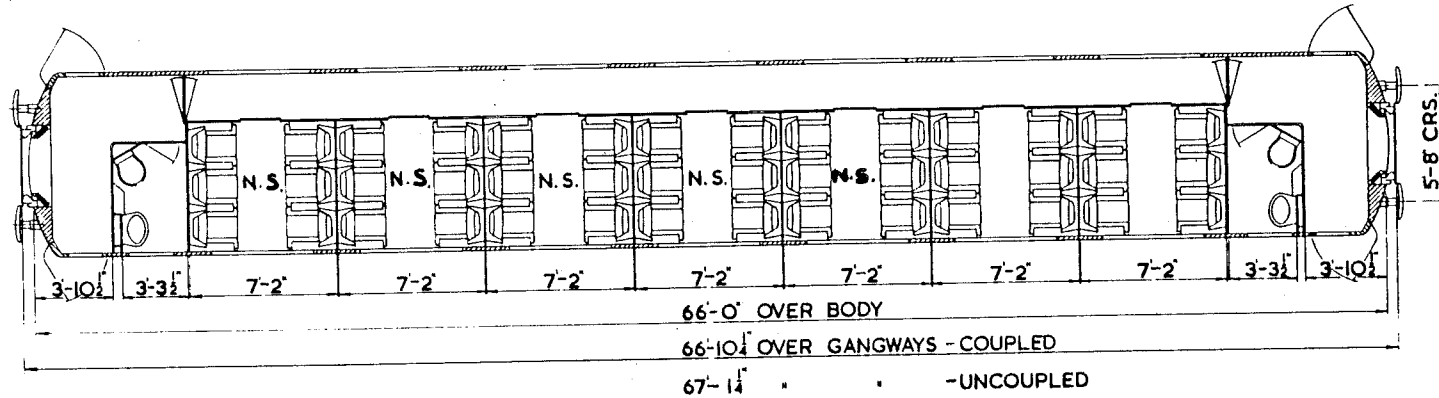
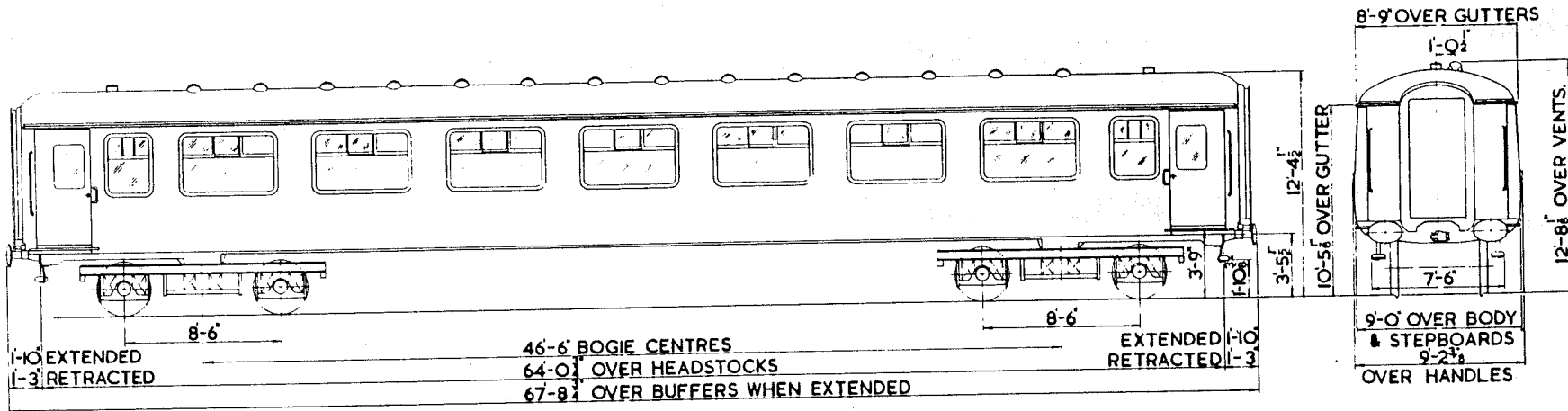

TARE
TONS 33.
N.S. - NON SMOKING.

- SEATS 42
- TILETS 2
- COMPARTMENTS 7
- GUARDS COMPARTMENTS -
- VENTILATION PRESSURE
- CATERING EQUIPMENT -

ORIGINAL DIAGRAMS FOR REFERENCE.-
BR 124

ISSUE 2 DATE OCT' 81

AA 107

BASIC TYPE

ALTERNATIVES

BRAKES
BOGIE/SUSPENSION
BODY CONSTRUCTION
COUPLINGS
TRAIN HEATING
E.T.H. INDEX
MAX. SPEED M.P.H.
MIN. RAD. CURVE CHAINS
LIGHTING
TARE WEIGHT TONNES
GANGWAYS
TRAIN COMMUNICATION
BUFFERS

AIR
B4
STEEL
AUTOMATIC DROPHEAD (BUCKEYE)
DUAL (STEAM/ELECTRIC (BR)) WITH PRESSURE VENTILATION & HEATING
4
100
3.5
FLUORESCENT & TUNGSTEN
33.5
PULLMAN
NOT FITTED
RETRACTABLE SPINDLE (559X356 OVAL)

TRACTION DATA FOR MULTIPLE UNITS

BASIC TYPE

AA 107 0A

VARIANTS

NONE

FIRST CORRIDOR-MK IIC

CLASS ---

FK

AA 108

VENT. TYPE 'GM' FOR VEH. No. M13514-M13533.
VENT. TYPE 'ROEVAC' TW 50 FOR VEH. No. M13534-M13561.

WINDOWS DRG No. SC/SW. 2814 FOR VEH. No. M13514-M13533.
WINDOWS DRG No. C-AO-1115 FOR VEH. No. M13534-M13561.

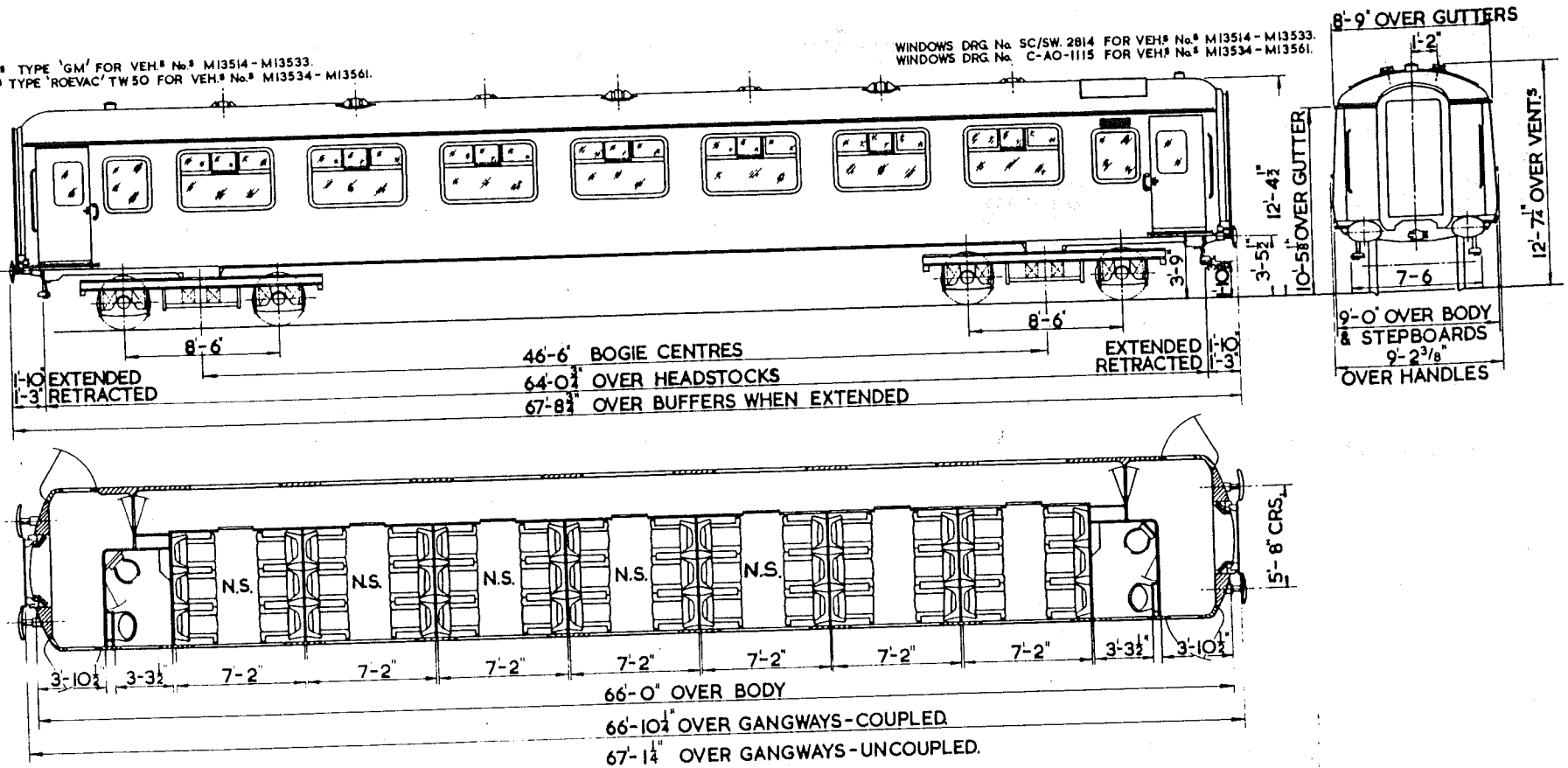

N.S.- NON SMOKING.

SEATS	42
TOILETS	2
COMPARTMENTS	7
GUARDS COMPARTMENTS	-
VENTILATION	PRESSURE
CATERING EQUIPMENT	-

ORIGINAL DIAGRAMS FOR REFERENCE.-
BR 125

ISSUE 3 DATE DEC '81

AA 108

BASIC TYPE

AIR
 B4
 STEEL
 AUTOMATIC DROPHEAD (BUCKEYE)
 DUAL (STEAM/ELECTRIC (BR)) WITH PRESSURE VENTILATION & HEATING
 4
 100
 3.5
 FLUORESCENT & TUNGSTEN
 34
 PULLMAN
 NOT FITTED
 RETRACTABLE SPINDLE (559X356 OVAL)
 CAST IRON

ALTERNATIVES

BRAKES
 BOGIE/SUSPENSION
 BODY CONSTRUCTION
 COUPLINGS
 TRAIN HEATING
 E. T. H. INDEX
 MAX. SPEED M. P. H.
 MIN. RAD. CURVE CHAINS
 LIGHTING
 TARE WEIGHT TONNES
 GANGWAYS
 TRAIN COMMUNICATION
 BUFFERS
 BRAKE BLOCKS

PUBLIC ADDRESS
 COMPOSITION

TRACTION DATA FOR MULTIPLE UNITS

BASIC TYPE

AA 108 0A

VARIANTS

0B COMPOSITION BRAKE BLOCKS.
 1A PUBLIC ADDRESS.
 1B PUBLIC ADDRESS, COMPOSITION BRAKE BLOCKS.

FIRST CORRIDOR-MK IID

CLASS ---

FK

AA 109

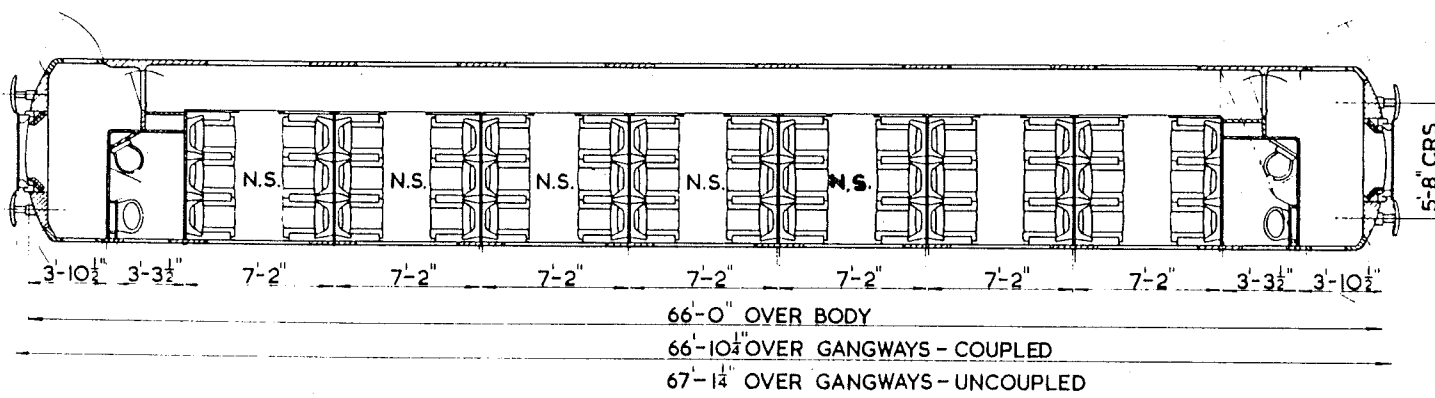
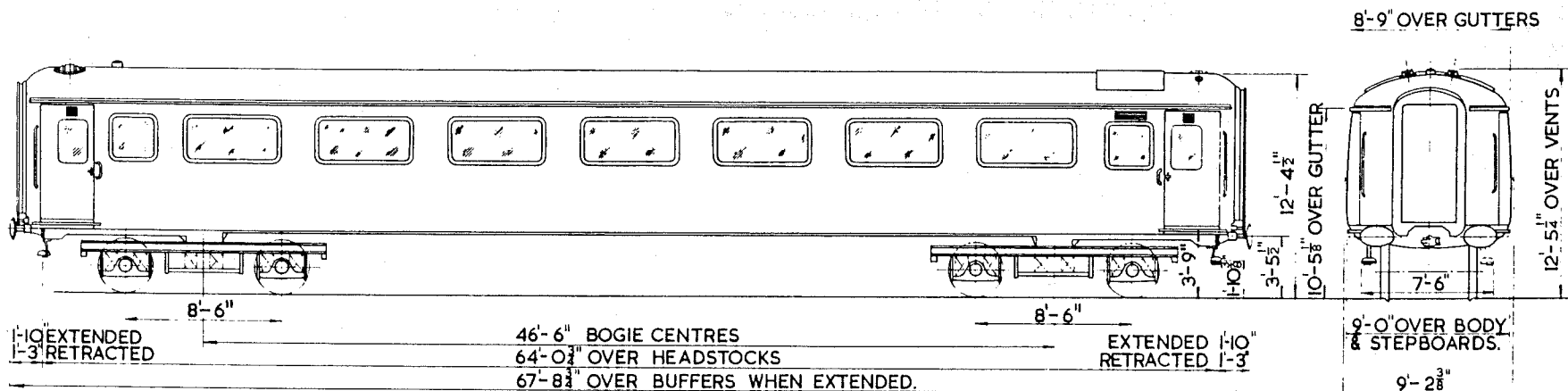

N.S. - NON SMOKING

- SEATS
- TOILETS
- COMPARTMENTS
- GUARDS COMPARTMENTS
- VENTILATION
- CATERING EQUIPMENT

- 42
- 2
- 7
-
- FULL AIR CONDITIONING
-

ORIGINAL DIAGRAMS FOR REFERENCE, - BR 129

ISSUE 2 DATE OCT '81

AA 109

BASIC TYPE

BRAKES
BOGIE/SUSPENSION
BODY CONSTRUCTION
COUPLINGS
TRAIN HEATING
E.T.H. INDEX
MAX. SPEED M.P.H.
MIN. RAD. CURVE CHAINS
LIGHTING
TARE WEIGHT TONNES
GANGWAYS
TRAIN COMMUNICATION
BUFFERS

AIR
B4
STEEL
AUTOMATIC DROPHEAD (BUCKEYE)
ELECTRIC (BR) FULL AIR CONDITIONING (NOT SUITED TO CLASS 55 LOCOS)
5
100
3.5
FLUORESCENT & TUNGSTEN
35
PULLMAN
PUBLIC ADDRESS
RETRACTABLE SPINDLE (559X356 OVAL)

ALTERNATIVES

ELECTRIC (BR) FULL AIR CONDITIONING

TRACTION DATA FOR MULTIPLE UNITS

BASIC TYPE

AA 109 0A

VARIANTS

1A ELECTRIC (BR) FULL AIR CONDITIONING.

SECOND CORRIDOR-MK 1

CLASS ---

SK

AA 201

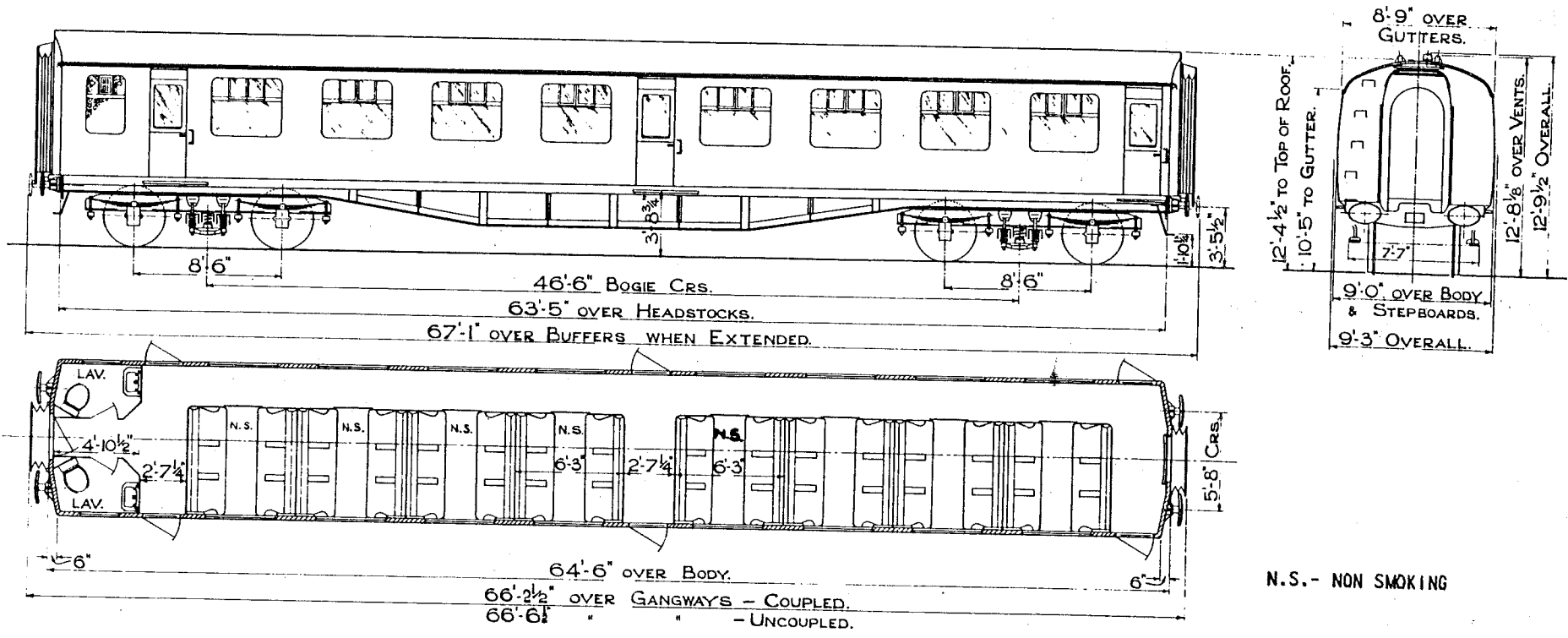

N.S. - NON SMOKING

SEATS	48
TOILETS	2
COMPARTMENTS	8
GUARDS COMPARTMENTS	-
VENTILATION	-
CATERING EQUIPMENT	-

ORIGINAL DIAGRAMS FOR REFERENCE:-
BR 146

ISSUE 5 DATE DEC 86

AA 201

BRAKES
BOGIE/SUSPENSION
BODY CONSTRUCTION
COUPLINGS
TRAIN HEATING
E.T.H. INDEX
MAX. SPEED M.P.H.
MIN. RAD. CURVE CHAINS
LIGHTING
TARE WEIGHT TONNES
GANGWAYS
TRAIN COMMUNICATION
BUFFERS

BASIC TYPE

VACUUM
COMMONWEALTH
STEEL
AUTOMATIC DROPHEAD(BUCKEYE)
STEAM
-
100
3.5
TUNGSTEN
34
PULLMAN
NOT FITTED
RETRACTABLE SPINDLE(559X356 OVAL)

ALTERNATIVES

VACUUM & AIR
BR MK 1 LIGHT DOUBLE BOLSTER, B4.

DUAL (STEAM/ELECTRIC(BR))
4
90

FLUORESCENT & TUNGSTEN
35

TRACTION DATA FOR MULTIPLE UNITSBASIC TYPE

AA 201 OA

VARIANTS

- 0C BR MK 1 LIGHT DOUBLE BOLSTER BOGIES, MAX. SPEED 90.
1A DUAL HEATING(STEAM/ELECTRIC(BR)), E.T.H. 4, TARE 35
1B DUAL HEATING(STEAM/ELECTRIC(BR)), B4 BOGIES, E.T.H. 4.
1C DUAL HEATING(STEAM/ELECTRIC(BR)), BR MK 1 LIGHT DOUBLE BOLSTER BOGIES, E.T.H. 4, MAX. SPEED 90.
1E DUAL HEATING(STEAM/ELECTRIC(BR)), E.T.H. 4, VACUUM & AIR BRAKES.
1F DUAL HEATING(STEAM/ELECTRIC(BR)), B4 BOGIES, E.T.H. 4, VACUUM & AIR BRAKES.
2A FLUORESCENT & TUNGSTEN LIGHTING.
3A DUAL HEATING(STEAM/ELECTRIC(BR)), E.T.H. 4, FLUORESCENT & TUNGSTEN LIGHTING.
3C DUAL HEATING(STEAM/ELECTRIC(BR)), BR MK 1 LIGHT DOUBLE BOLSTER BOGIES, E.T.H. 4, MAX. SPEED 90, FLUORESCENT & TUNGSTEN LIGHTING.

SECOND CORRIDOR-MK 1

CLASS ---

SK

AA 202

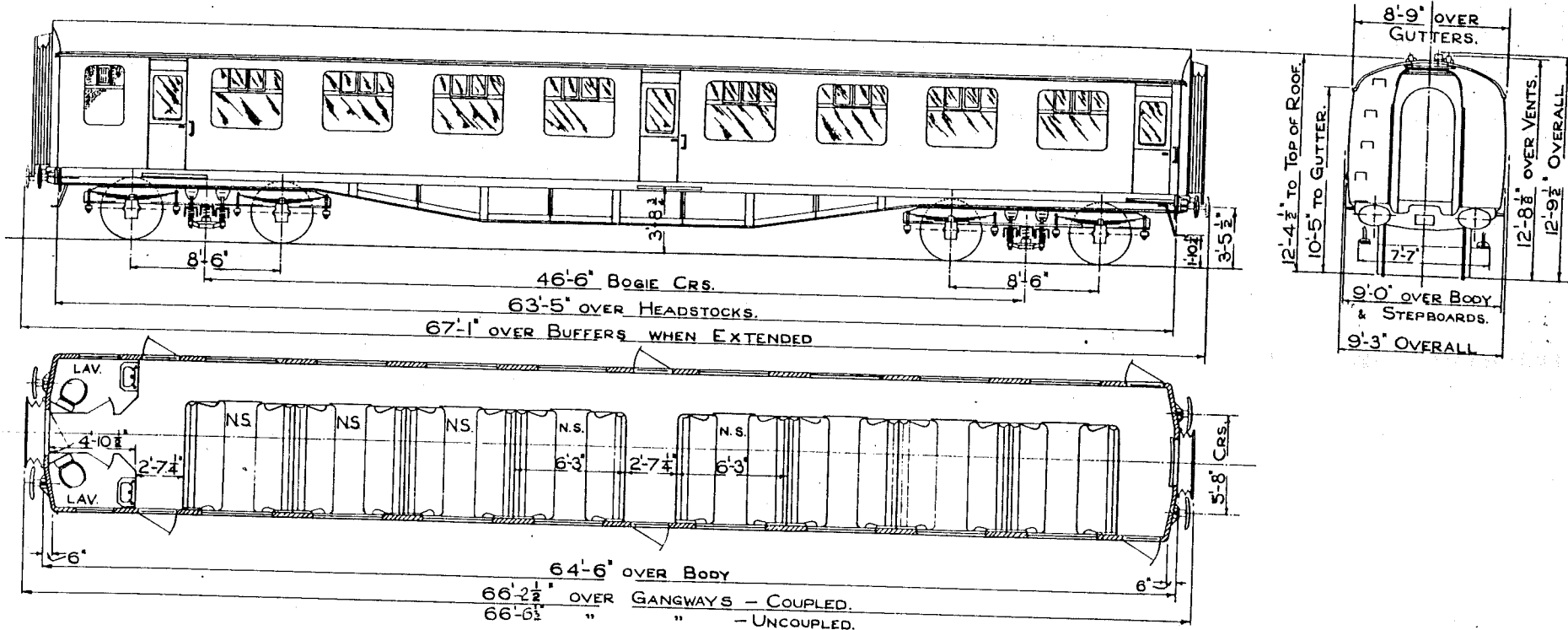

N.S. - NON SMOKING

SEATS	64
TOILETS	2
COMPARTMENTS	8
GUARDS COMPARTMENTS	-
VENTILATION	-
CATERING EQUIPMENT	-

ORIGINAL DIAGRAMS FOR REFERENCE:-
BR 147

ISSUE 4
DATE OCT 86

AA 202

BRAKES
BOGIE/SUSPENSION
BODY CONSTRUCTION
COUPLINGS
TRAIN HEATING
E.T.H. INDEX
MAX. SPEED M.P.H.
MIN. RAD. CURVE CHAINS
LIGHTING
TARE WEIGHT TONNES
GANGWAYS
TRAIN COMMUNICATION
BUFFERS

BASIC TYPE

VACUUM
COMMONWEALTH
STEEL
AUTOMATIC DROPHEAD(BUCKEYE)
STEAM
-
100
3.5
TUNGSTEN
34
PULLMAN
NOT FITTED
RETRACTABLE SPINDLE(559X356 OVAL)

ALTERNATIVES

AIR
BR MK 1 LIGHT DOUBLE BOLSTER,B4.

DUAL (STEAM/ELECTRIC(BR)),ELECTRIC (BR).
4
90

FLUORESCENT & TUNGSTEN

TRACTION DATA FOR MULTIPLE UNITSBASIC TYPE

AA 202 OA

VARIANTS

OB B4 BOGIES
OC BR MK 1 LIGHT DOUBLE BOLSTER BOGIES,MAX.SPEED 90.
1A DUAL HEATING(STEAM/ELECTRIC(BR)),E.T.H.4.
1F DUAL HEATING(STEAM/ELECTRIC(BR)),E.T.H.4,B4 BOGIES.
1G DUAL HEATING(STEAM/ELECTRIC(BR)),E.T.H.4,BR MK 1 LIGHT DOUBLE BOLSTER BOGIES,MAX.SPEED 90.
2D ELECTRIC(BR)HEATING,E.T.H.4,AIR BRAKES,MAX.SPEED 90.
2E ELECTRIC(BR)HEATING,E.T.H.4,AIR BRAKES,BR MK 1 LIGHT DOUBLE BOLSTER BOGIES,MAX.SPEED 90.
3A DUAL HEATING(STEAM/ELECTRIC(BR)),FLUORESCENT & TUNGSTEN,E.T.H.4.
3F DUAL HEATING(STEAM/ELECTRIC(BR)),FLUORESCENT & TUNGSTEN,E.T.H.4,B4 BOGIES.
3G DUAL HEATING(STEAM/ELECTRIC(BR)),E.T.H.4,BR MK 1 LIGHT DOUBLE BOLSTER BOGIES,MAX.SPEED 90,FLUORESCENT & TUNGSTEN.

SECOND CORRIDOR-MK I

CLASS ---

SK

AA 204

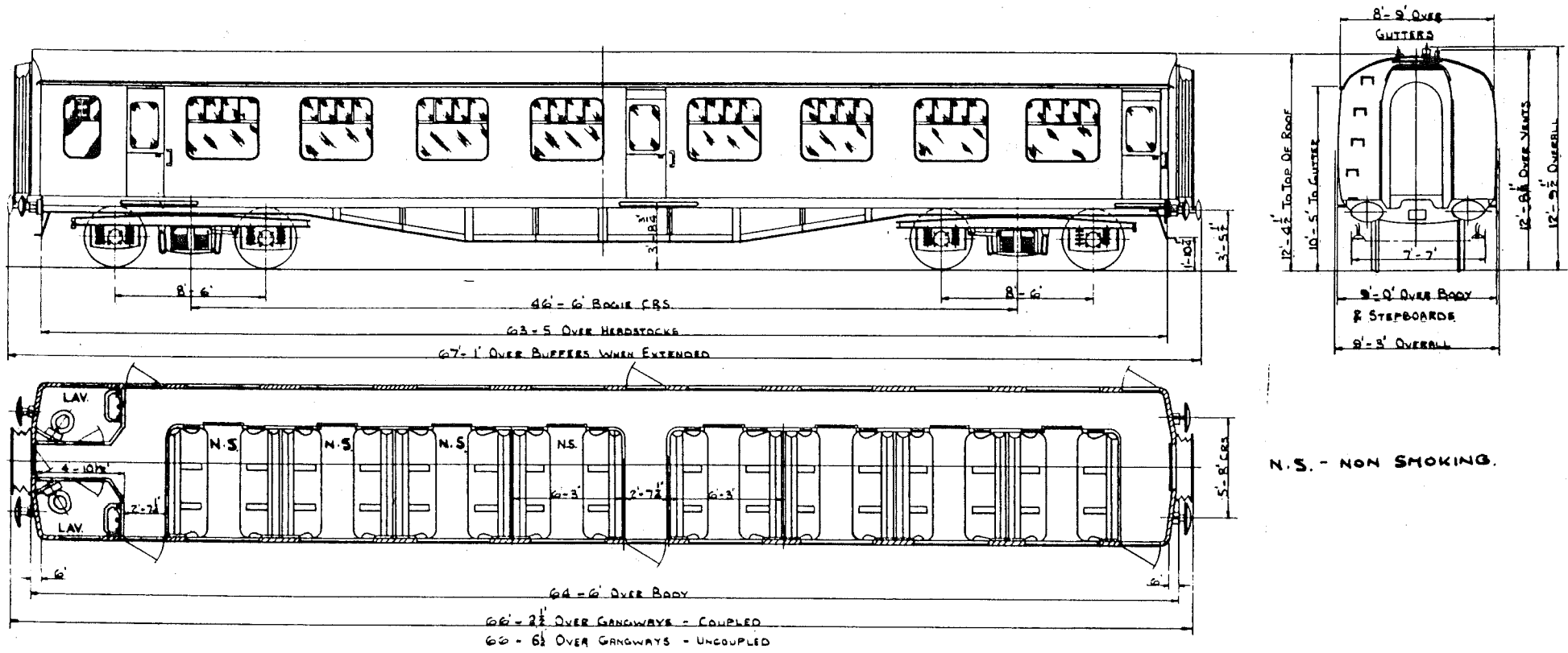

N.S. - NON SMOKING.

SEATS	48
TOILETS	2
COMPARTMENTS	8
GUARDS COMPARTMENTS	-
VENTILATION	-
CATERING EQUIPMENT	-

ORIGINAL DIAGRAMS FOR REFERENCE.-
BR 150

ISSUE 1 DATE SEP' 80

AA 204

BASIC TYPE

ALTERNATIVES

BRAKES
BOGIE/SUSPENSION
BODY CONSTRUCTION
COUPLINGS
TRAIN HEATING
E.T.H. INDEX
MAX. SPEED M.P.H.
MIN. RAD. CURVE CHAINS
LIGHTING
TARE WEIGHT TONNES
GANGWAYS
TRAIN COMMUNICATION
BUFFERS

VACUUM
BR MK 1 LIGHT DOUBLE BOLSTER
STEEL
AUTOMATIC DROPHEAD (BUCKEYE)
STEAM
-
90
3.5
ELECTRIC
31.5
PULLMAN
NOT FITTED
RETRACTABLE SPINDLE (559X356 OVAL)

TRACTION DATA FOR MULTIPLE UNITS

BASIC TYPE

AA 204 OA

VARIANTS

NONE

SECOND CORRIDOR-MK 11B

CLASS ---

SK

AA 207

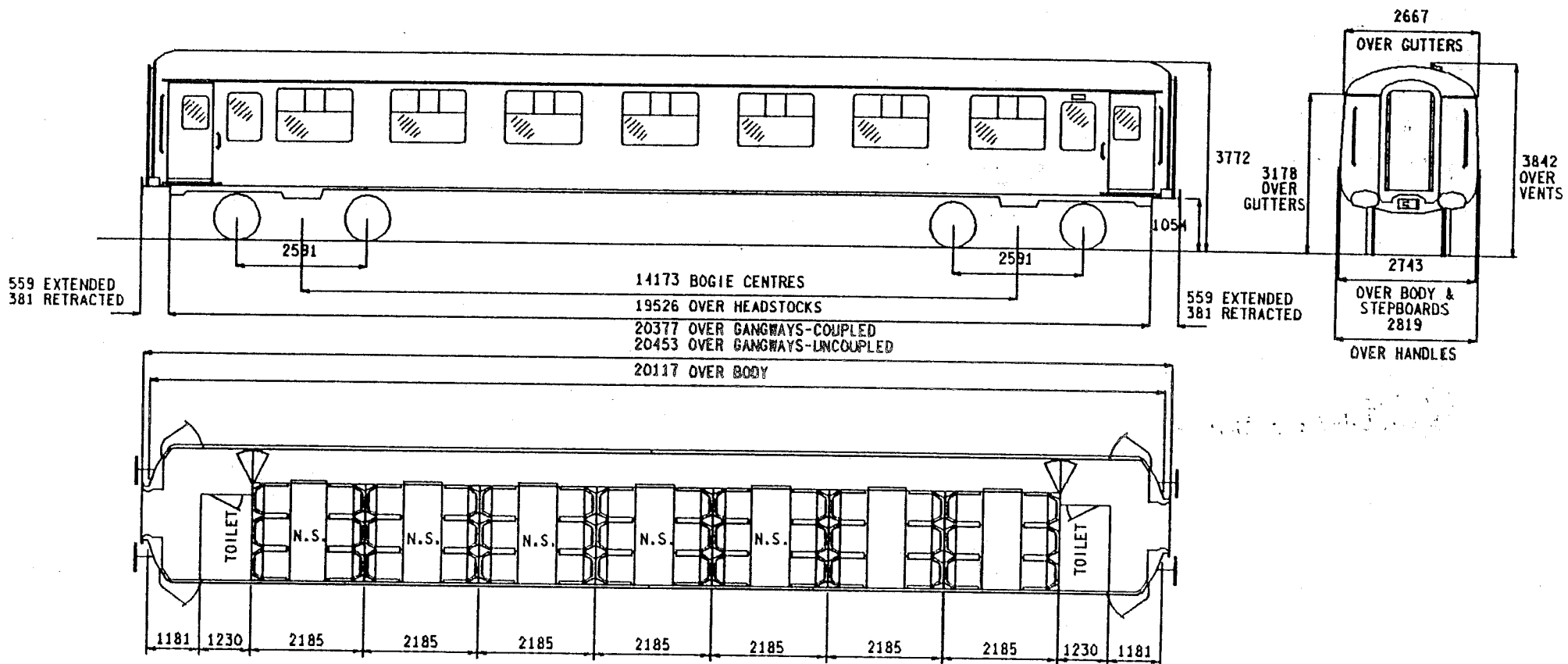

N.S. = NON SMOKING

SEATS	56
TOILETS	2
COMPARTMENTS	7
GUARDS COMPARTMENTS	-
VENTILATION	PRESSURE
CATERING EQUIPMENT	-

ORIGINAL DIAGRAMS FOR REFERENCE:-
BR 124

ISSUE 1 DATE OCT '86

AA 207

BASIC TYPE

ALTERNATIVES

BRAKES
BOGIE/SUSPENSION
BODY CONSTRUCTION
COUPLINGS
TRAIN HEATING
E.T.H. INDEX
MAX. SPEED M.P.H.
MIN. RAD. CURVE CHAINS
LIGHTING
TARE WEIGHT TONNES
GANGWAYS
TRAIN COMMUNICATION
BUFFERS

AIR
B4
STEEL
AUTOMATIC DROPHEAD(BUCKEYE)
DUAL(STEAM/ELECTRIC(BR))WITH PRESSURE VENTILATION & HEATING
4
100
3.5
FLUORESCENT & TUNGSTEN
33.5
PULLMAN
NOT FITTED
RETRACTABLE SPINDLE(559X356 OVAL)

TRACTION DATA FOR MULTIPLE UNITS

BASIC TYPE

AA 207 OA

VARIANTS

NONE

SECOND CORRIDOR-MK 11C

CLASS ---

SK

AA 208

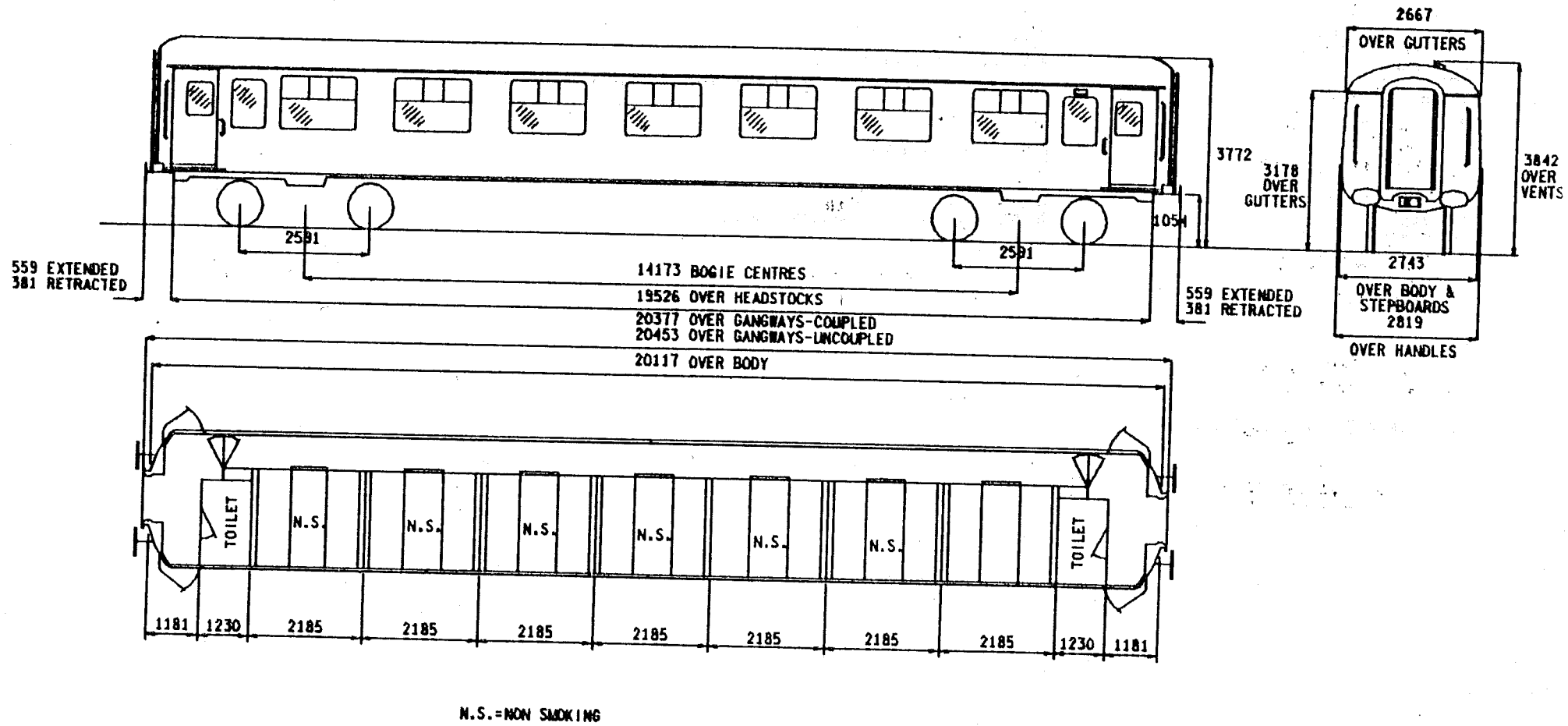

SEATS	56
TOILETS	2
COMPARTMENTS	-
GUARDS COMPARTMENTS	-
VENTILATION	PRESSURE
CATERING EQUIPMENT	-

ORIGINAL DIAGRAMS FOR REFERENCE:-
BR 125

ISSUE 1 DATE OCT '86

AA 208

**BRAKES
BOGIE/SUSPENSION
BODY CONSTRUCTION
COUPLINGS
TRAIN HEATING
E.T.H. INDEX
MAX.SPEED M.P.H.
MIN.RAD.CURVE CHAINS
LIGHTING
TARE WEIGHT TONNES
GANGWAYS
TRAIN COMMUNICATION
BUFFERS
BRAKE BLOCKS**

BASIC TYPE

**AIR
B4
STEEL
AUTOMATIC DROPHEAD(BUCKEYE)
DUAL(STEAM/ELECTRIC(BR))WITH PRESURE VENTILATION & HEATING
4
100
3.5
FLUORESCENT & TUNGSTEN
32
PULLMAN
NOT FITTED
RETRACTABLE SPINDLE(559X356 OVAL)
CAST IRON**

ALTERNATIVES

COMPOSITION

TRACTION DATA FOR MULTIPLE UNITS

BASIC TYPE

AA 208 OA

VARIANTS

OB COMPOSITION BRAKE BLOCKS

SECOND CORRIDOR-MK 11A

CLASS ---

SK

AA 209

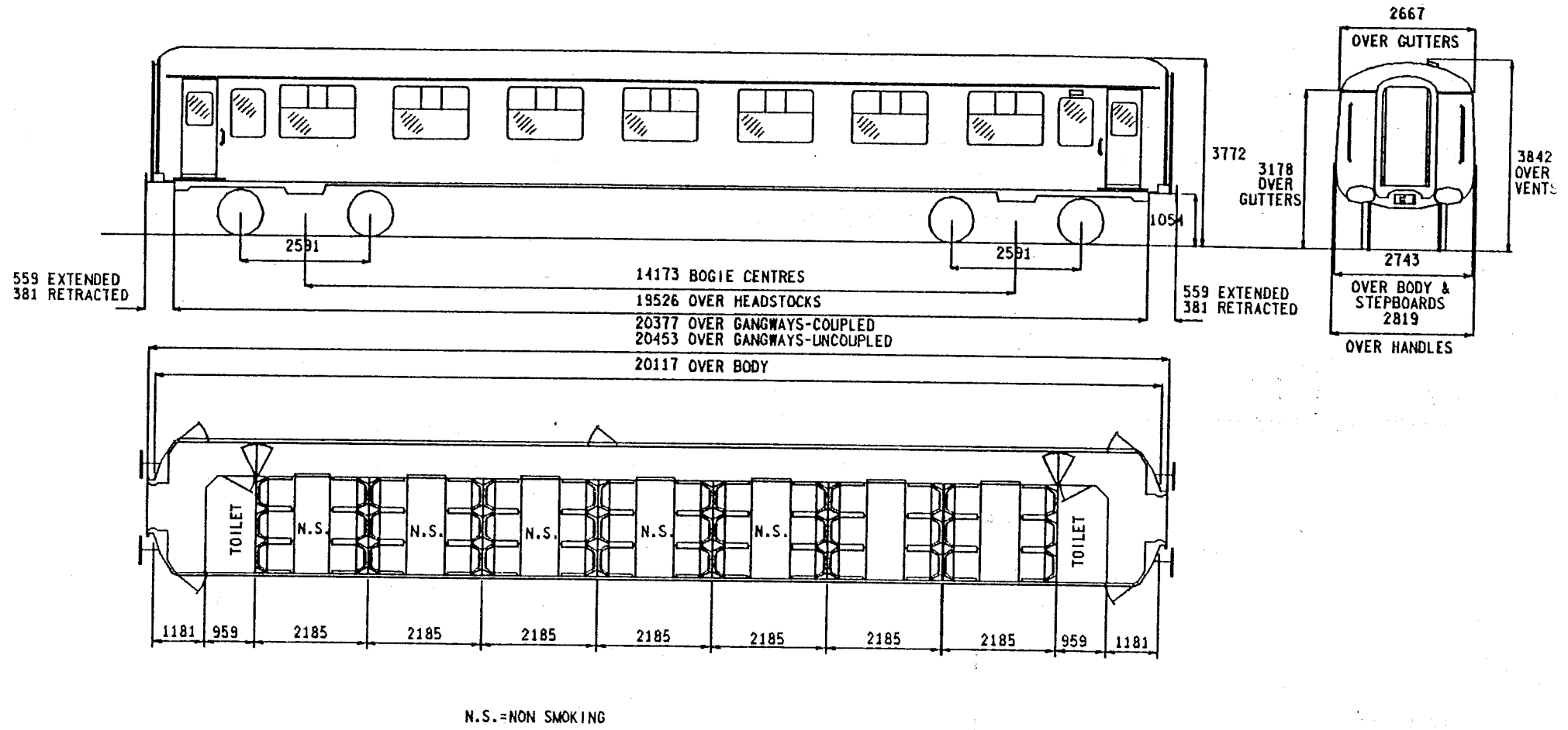

SEATS	42
TOILETS	2
COMPARTMENTS	7
GUARDS COMPARTMENTS	-
VENTILATION	PRESSURE
CATERING EQUIPMENT	-

ORIGINAL DIAGRAMS FOR REFERENCE:-
BR 123

ISSUE 1 DATE OCT '86

AA 209

BRAKES
BOGIE/SUSPENSION
BODY CONSTRUCTION
COUPLINGS
TRAIN HEATING
E.T.H. INDEX
MAX. SPEED M.P.H.
MIN. RAD. CURVE CHAINS
LIGHTING
TARE WEIGHT TONNES
GANGWAYS
TRAIN COMMUNICATION
BUFFERS

BASIC TYPE

AIR
B4
STEEL
AUTOMATIC DROPHEAD(BUCKEYE)
DUAL(STEAM/ELECTRIC(BR))WITH PRESSURE VENTILATION & HEATING
4
100
3.5
FLUORESCENT & TUNGSTEN
32
PULLMAN
NOT FITTED
RETRACTABLE SPINDLE(559X356 OVAL)

ALTERNATIVES

VACUUM

TRACTION DATA FOR MULTIPLE UNITS

BASIC TYPE

AA 209 OA

VARIANTS

OB VACUUM BRAKES.

COMPOSITE CORRIDOR-MK 1

CLASS ---

CK

AA 301

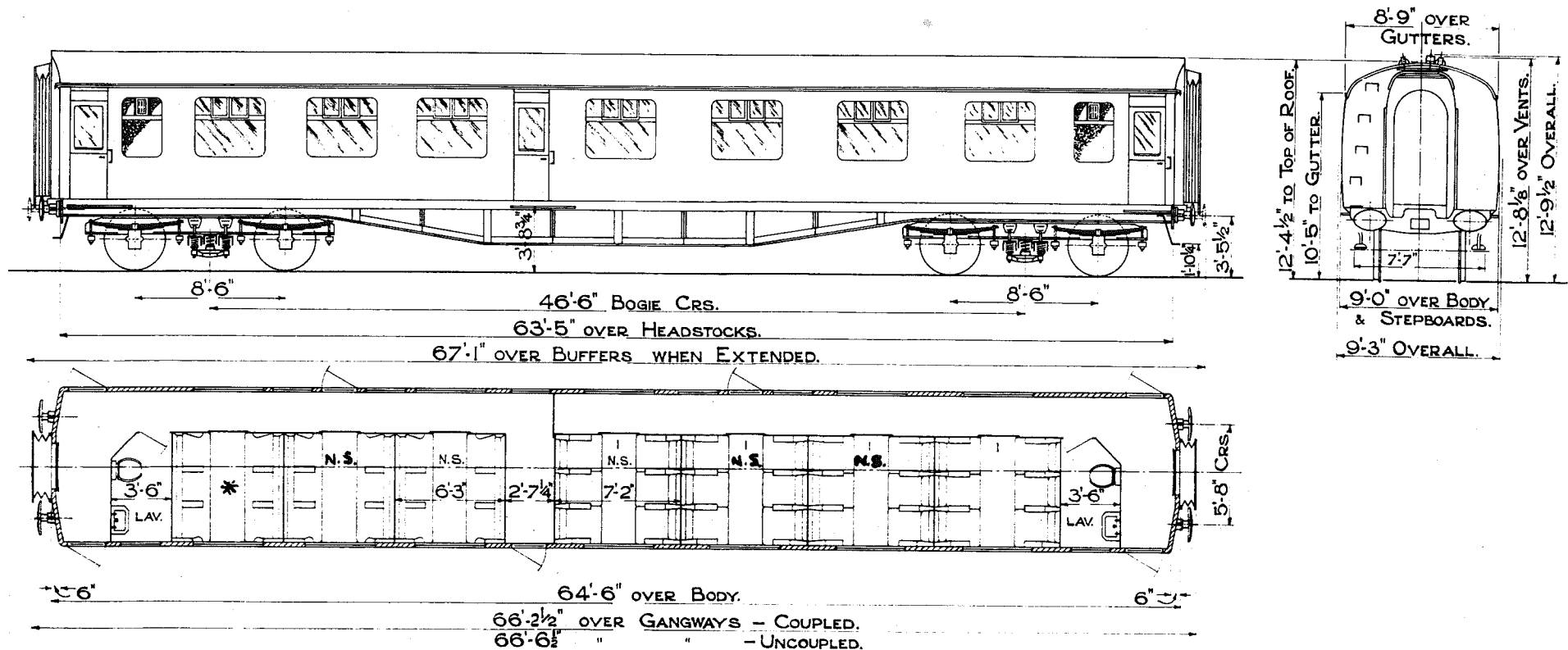

THIS COMPARTMENT N.S. ON SOME VEHICLES. SEE VARIANTS

N.S.-NON SMOKING

SEATS
TOILETS
COMPARTMENTS
GUARDS COMPARTMENTS
VENTILATION
CATERING EQUIPMENT

24 FIRST CLASS, 18 SECOND CLASS
2
4 FIRST CLASS, 3 SECOND CLASS
-
-
-

ORIGINAL DIAGRAMS FOR REFERENCE:-
BR 126

ISSUE 4 DATE MAR 89

AA 301

	<u>BASIC TYPE</u>	<u>ALTERNATIVES</u>
BRAKES	VACUUM	
BOGIE/SUSPENSION	COMMONWEALTH	B4, BR MK 1 LIGHT DOUBLE BOLSTER
BODY CONSTRUCTION	STEEL	
COUPLINGS	AUTOMATIC DROPHEAD(BUCKEYE)	
TRAIN HEATING	STEAM	DUAL(STEAM/ELECTRIC(BR))
E.T.H. INDEX	-	3
MAX.SPEED M.P.H.	100	90
MIN.RAD.CURVE CHAINS	3.5	
LIGHTING	TUNGSTEN	FLUORESCENT & TUNGSTEN
TARE WEIGHT TONNES	34	
GANGWAYS	PULLMAN	
TRAIN COMMUNICATION	NOT FITTED	FITTED
BUFFERS	RETRACTABLE SPINDLE(559X356 OVAL)	
SMOKING ACCOMMODATION	75% NON SMOKING	86% NON SMOKING

TRACTION DATA FOR MULTIPLE UNITSBASIC TYPE

AA 301 OA

VARIANTS

- OB B4 BOGIES.
- OC BR MK 1 LIGHT DOUBLE BOLSTER BOGIES, MAX.SPEED 90.
- 1A DUAL HEATING(STEAM/ELECTRIC(BR)), E.T.H.3.
- 1B DUAL HEATING(STEAM/ELECTRIC(BR)), E.T.H.3, B4 BOGIES.
- 1C DUAL HEATING(STEAM/ELECTRIC(BR)), E.T.H.3, BR MK 1 LIGHT DOUBLE BOLSTER BOGIES, MAX.SPEED 90.
- 1D DUAL HEATING(STEAM/ELECTRIC(BR)), E.T.H.3, 86% NON SMOKING
- 1E DUAL HEATING(STEAM/ELECTRIC(BR)), E.T.H.3, BR MK 1 LIGHT DOUBLE BOLSTER BOGIES, MAX.SPEED 90, 86% NON SMOKING
- 2C BR MK 1 LIGHT DOUBLE BOLSTER BOGIES, MAX.SPEED 90, FLUORESCENT & TUNGSTEN LIGHTING.
- 3A DUAL HEATING(STEAM/ELECTRIC(BR)), P.A.FITTED, E.T.H.3.
- 3D DUAL HEATING(STEAM/ELECTRIC(BR)), P.A.FITTED, E.T.H.3, 86% NON SMOKING

COMPOSITE CORRIDOR-MK I

CLASS ---

CK

AA 301

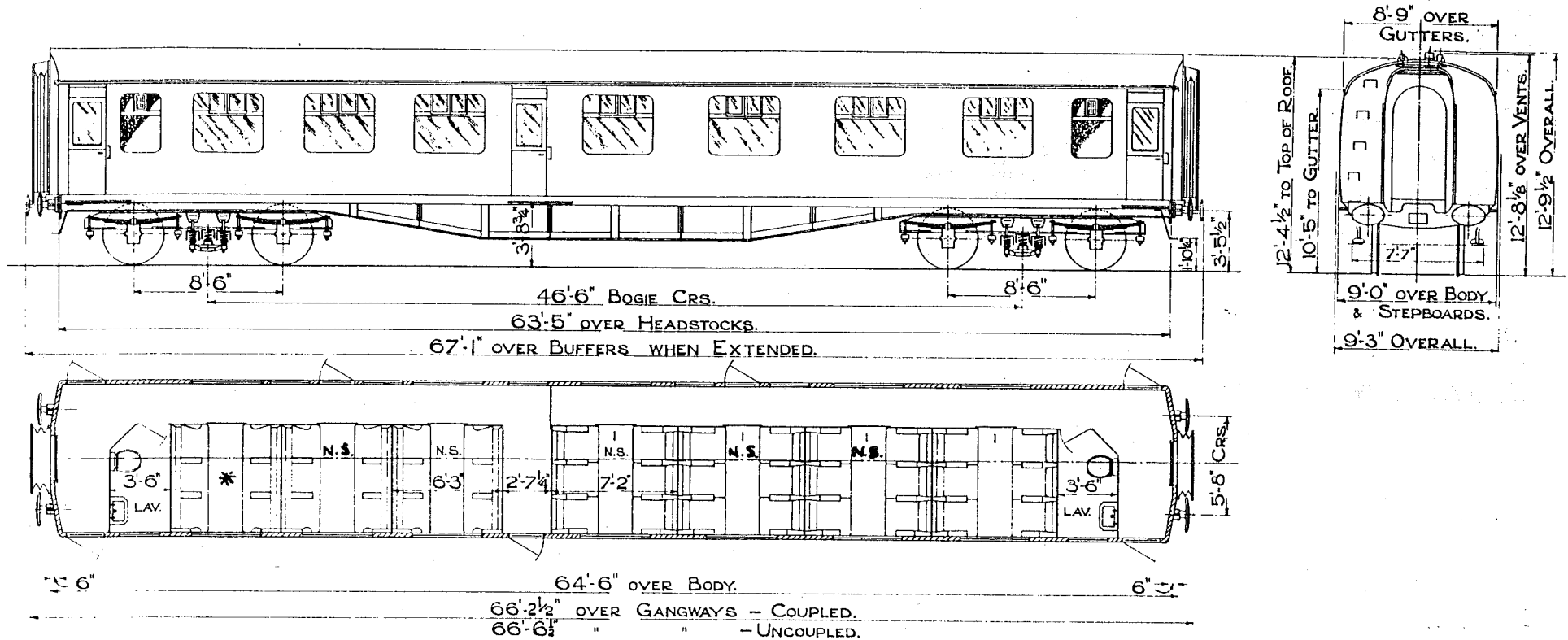

* THIS COMPARTMENT N.S. ON SOME VEHICLES. SEE VARIANTS

N.S. - NON SMOKING

- | | |
|---------------------|---------------------------------|
| SEATS | 24 FIRST CLASS, 18 SECOND CLASS |
| TOILETS | 2 |
| COMPARTMENTS | 4 FIRST CLASS, 3 SECOND CLASS |
| GUARDS COMPARTMENTS | - |
| VENTILATION | - |
| CATERING EQUIPMENT | - |

ORIGINAL DIAGRAMS FOR REFERENCE:- BR 126

ISSUE 3 DATE OCT '86

AA 301

BRAKES
 BOGIE/SUSPENSION
 BODY CONSTRUCTION
 COUPLINGS
 TRAIN HEATING
 E.T.H. INDEX
 MAX. SPEED M.P.H.
 MIN. RAD. CURVE CHAINS
 LIGHTING
 TARE WEIGHT TONNES
 GANGWAYS
 TRAIN COMMUNICATION
 BUFFERS
 SMOKING ACCOMMODATION

BASIC TYPE

VACUUM
 COMMONWEALTH
 STEEL
 AUTOMATIC DROPHEAD (BUCKEYE)
 STEAM
 -
 100
 3.5
 TUNGSTEN
 34
 PULLMAN
 NOT FITTED
 RETRACTABLE SPINDLE (559X356 OVAL)
 75% NON SMOKING

ALTERNATIVES

B4, BR MK 1 LIGHT DOUBLE BOLSTER

DUAL (STEAM/ELECTRIC (BR))
 3
 90

FLUORESCENT & TUNGSTEN

86% NON SMOKING

TRACTION DATA FOR MULTIPLE UNITSBASIC TYPE

AA 301 OA

VARIANTS

0B B4 BOGIES.
 0C BR MK 1 LIGHT DOUBLE BOLSTER BOGIES, MAX. SPEED 90.
 1A DUAL HEATING (STEAM/ELECTRIC (BR)), E.T.H. 3.
 1B DUAL HEATING (STEAM/ELECTRIC (BR)), E.T.H. 3, B4 BOGIES.
 1C DUAL HEATING (STEAM/ELECTRIC (BR)), E.T.H. 3, BR MK 1 LIGHT DOUBLE BOLSTER BOGIES, MAX. SPEED 90.
 2C BR MK 1 LIGHT DOUBLE BOLSTER BOGIES, MAX. SPEED 90, FLUORESCENT & TUNGSTEN LIGHTING.
 1D DUAL HEATING (STEAM/ELECTRIC (BR)), E.T.H. 3, 86% NON SMOKING
 1E DUAL HEATING (STEAM/ELECTRIC (BR)), E.T.H. 3, BR MK 1 LIGHT DOUBLE BOLSTER BOGIES, MAX. SPEED 90, 86% NON SMOKING

COMPOSITE CORRIDOR-MK I

CLASS ---

CK

AA 302

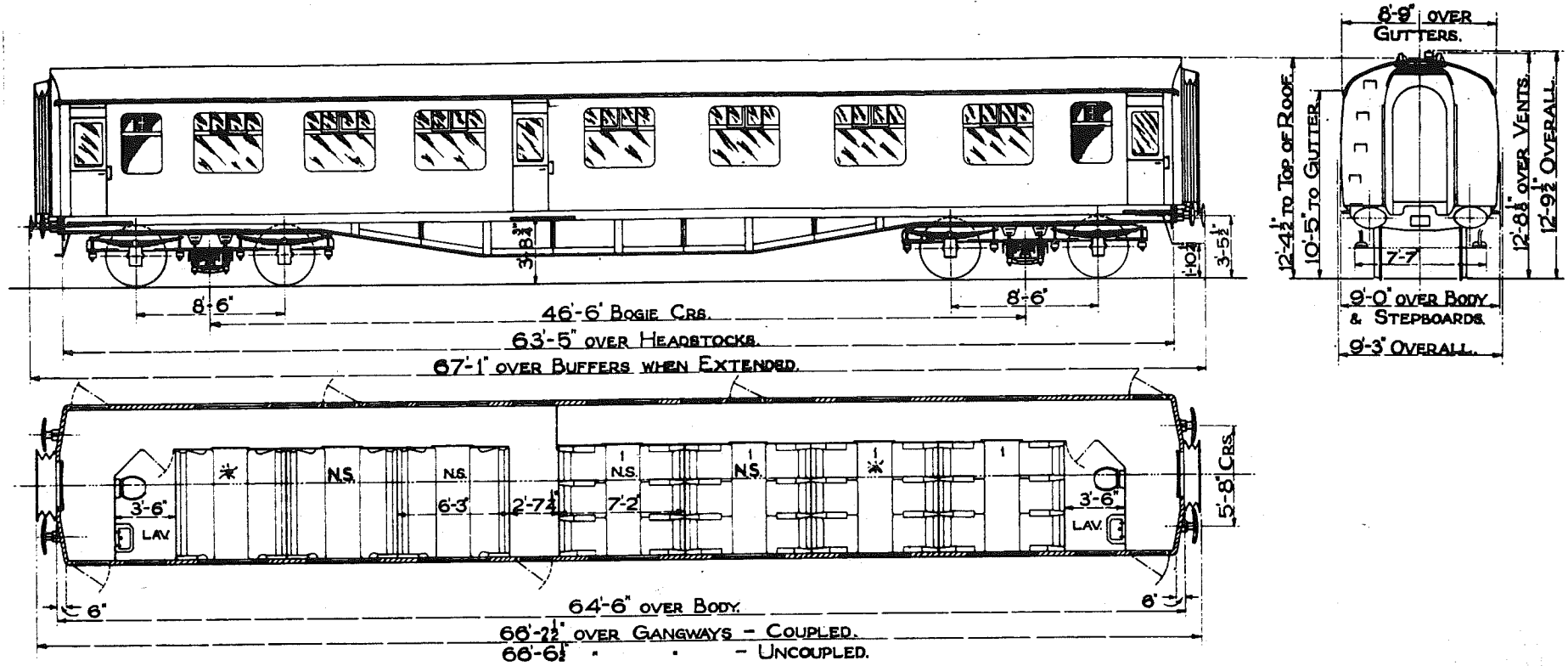

THESE COMPARTMENTS N.S.
ON SOME VEHICLES.SEE VARIANTS

N.S.- NON SMOKING

SEATS
TOILETS
COMPARTMENTS
GUARDS COMPARTMENTS
VENTILATION
CATERING EQUIPMENT

24 FIRST CLASS,24 SECOND CLASS
2
4 FIRST CLASS,3 SECOND CLASS

ORIGINAL DIAGRAMS FOR REFERENCE:-
BR 128

ISSUE 7 DATE MAR 89

AA 302

BRAKES
BOGIE/SUSPENSION
BODY CONSTRUCTION
COUPLINGS
TRAIN HEATING
E.T.H. INDEX
MAX. SPEED M.P.H.
MIN. RAD. CURVE CHAINS
LIGHTING
TARE WEIGHT TONNES
GANGWAYS
TRAIN COMMUNICATION
BUFFERS
SMOKING ACCOMMODATION

BASIC TYPE

VACUUM
COMMONWEALTH
STEEL
AUTOMATIC DROPHEAD (BUCKEYE)
DUAL (STEAM/ELECTRIC (BR))
-4
100
3.5
TUNGSTEN
34.5
PULLMAN
NOT FITTED
RETRACTABLE SPINDLE (559X356 OVAL)
57% NON SMOKING

ALTERNATIVES

B4, BR MK 1 LIGHT DOUBLE BOLSTER

STEAM
3, NO E.T.H. INDEX, -4 PLUS 600 AMP WIRING
90

FLUORESCENT & TUNGSTEN

FITTED

86% NON SMOKING

TRACTION DATA FOR MULTIPLE UNITSBASIC TYPE

AA 302 OA

VARIANTS

OB BR MK 1 LIGHT DOUBLE BOLSTER BOGIES, MAX SPEED 90.
OK 86% NON SMOKING.
2D E.T.H. INDEX 3.
2H E.T.H. INDEX 3, B4 BOGIES.
2J E.T.H. INDEX 3, BR MK 1 LIGHT DOUBLE BOLSTER BOGIES, MAX. SPEED 90.
2L E.T.H. INDEX 3, 86% NON SMOKING
3D E.T.H. INDEX 3, FLUORESCENT & TUNGSTEN LIGHTING.
3H E.T.H. INDEX 3, B4 BOGIES, FLUORESCENT & TUNGSTEN LIGHTING.
3J E.T.H. INDEX 3, BR MK 1 LIGHT DOUBLE BOLSTER BOGIES, MAX. SPEED 90, FLUORESCENT & TUNGSTEN LIGHTING
4E STEAM HEATING, NO E.T.H. INDEX, B4 BOGIES.
5A FLUORESCENT & TUNGSTEN LIGHTING
5K FLUORESCENT & TUNGSTEN LIGHTING, 86% NON SMOKING
6A FLUORESCENT & TUNGSTEN LIGHTING, P.A. FITTED.

COMPOSITE CORRIDOR-MK I

CLASS ---

CK

AA 302

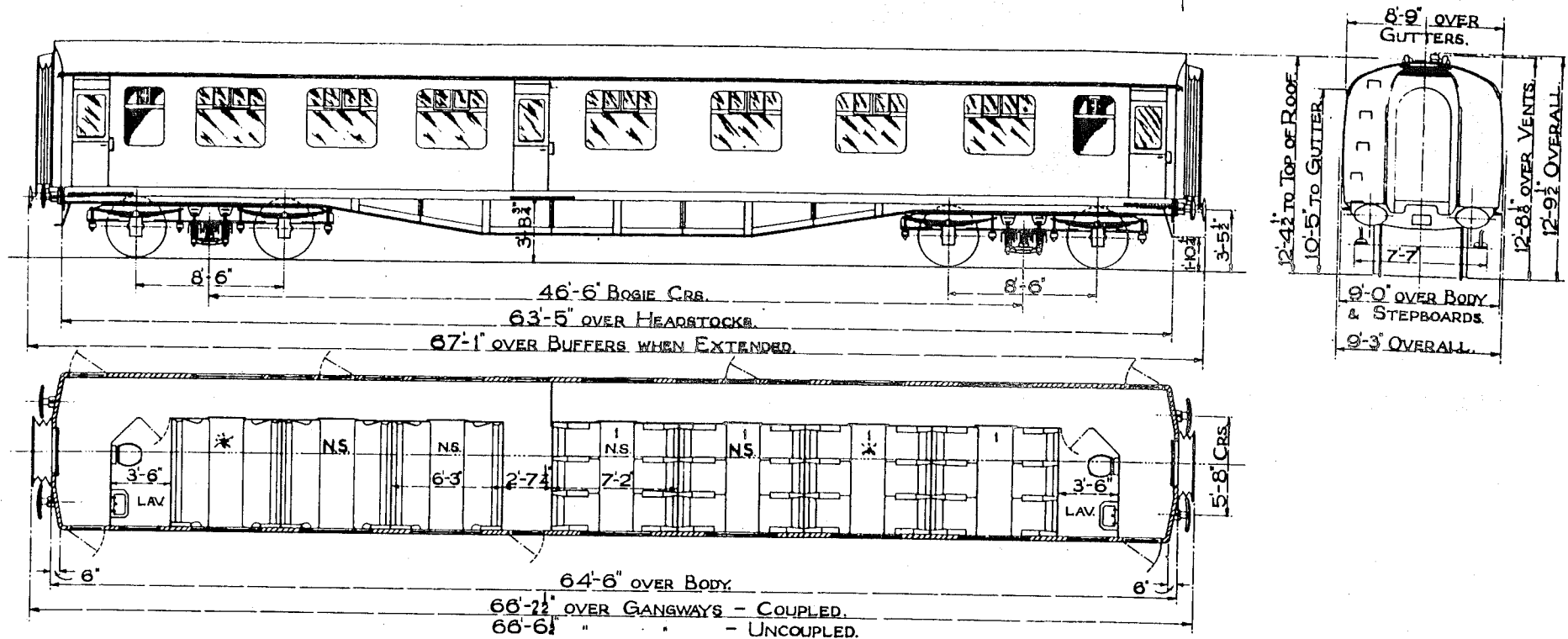

THESE COMPARTMENTS N.S.
ON SOME VEHICLES.SEE VARIANTS

N.S.- NON SMOKING

SEATS	24 FIRST CLASS, 24 SECOND CLASS
TOILETS	2
COMPARTMENTS	4 FIRST CLASS, 3 SECOND CLASS
GUARDS COMPARTMENTS	-
VENTILATION	-
CATERING EQUIPMENT	-

ORIGINAL DIAGRAMS FOR REFERENCE:-
BR 128

ISSUE 6 DATE MAR 87

AA 302

BASIC TYPE

BRAKES
 BOGIE/SUSPENSION
 BODY CONSTRUCTION
 COUPLINGS
 TRAIN HEATING
 E.T.H. INDEX
 MAX. SPEED M.P.H.
 MIN. RAD. CURVE CHAINS
 LIGHTING
 TARE WEIGHT TONNES
 GANGWAYS
 TRAIN COMMUNICATION
 BUFFERS
 SMOKING ACCOMMODATION

VACUUM
 COMMONWEALTH
 STEEL
 AUTOMATIC DROPHEAD(BUCKEYE)
 DUAL(STEAM/ELECTRIC(BR))
 4
 100
 3.5
 TUNGSTEN
 34.5
 PULLMAN
 NOT FITTED
 RETRACTABLE SPINDLE(559X356 OVAL)
 57% NON SMOKING

ALTERNATIVES

B4, BR MK 1 LIGHT DOUBLE BOLSTER

STEAM
 3, NO E.T.H. INDEX, 4 PLUS 600 AMP WIRING
 90

FLUORESCENT & TUNGSTEN

86% NON SMOKING

TRACTION DATA FOR MULTIPLE UNITSBASIC TYPE

AA 302 0A

VARIANTS

0B BR MK 1 LIGHT DOUBLE BOLSTER BOGIES, MAX SPEED 90.
 0K 86% NON SMOKING.
 2D E.T.H. INDEX 3.
 2H E.T.H. INDEX 3, B4 BOGIES.
 2J E.T.H. INDEX 3, BR MK 1 LIGHT DOUBLE BOLSTER BOGIES, MAX. SPEED 90.
 2L E.T.H. INDEX 3, 86% NON SMOKING
 3D E.T.H. INDEX 3, FLUORESCENT & TUNGSTEN LIGHTING.
 3H E.T.H. INDEX 3, B4 BOGIES, FLUORESCENT & TUNGSTEN LIGHTING.
 3J E.T.H. INDEX 3, BR MK 1 LIGHT DOUBLE BOLSTER BOGIES, MAX. SPEED 90, FLUORESCENT & TUNGSTEN LIGHTING
 4E STEAM HEATING, NO E.T.H. INDEX, B4 BOGIES.
 5A FLUORESCENT & TUNGSTEN LIGHTING
 5K FLUORESCENT & TUNGSTEN LIGHTING, 86% NON SMOKING

COMPOSITE CORRIDOR-MK 11

CLASS ---

CK

AA 303

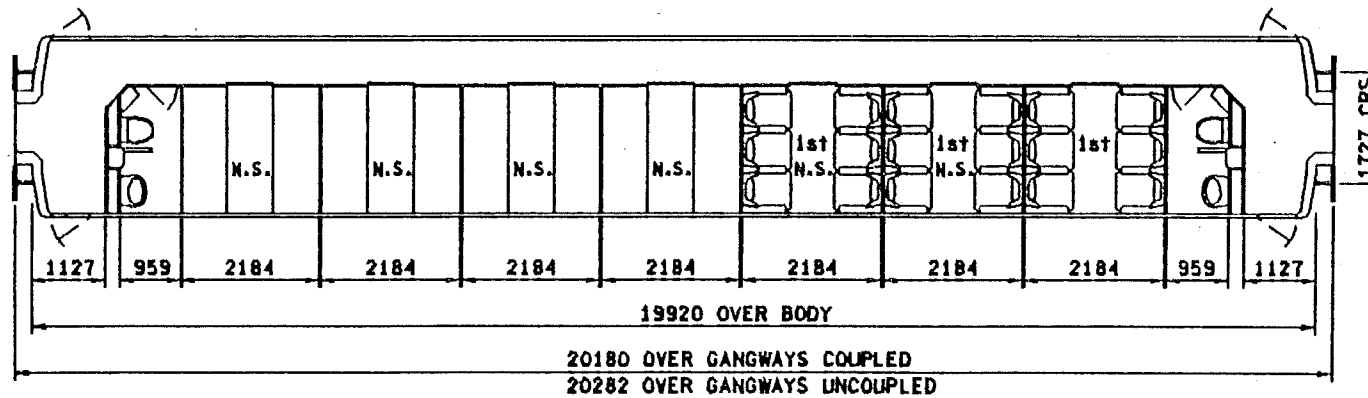
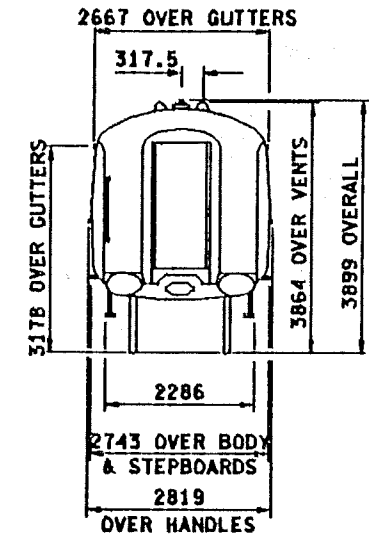
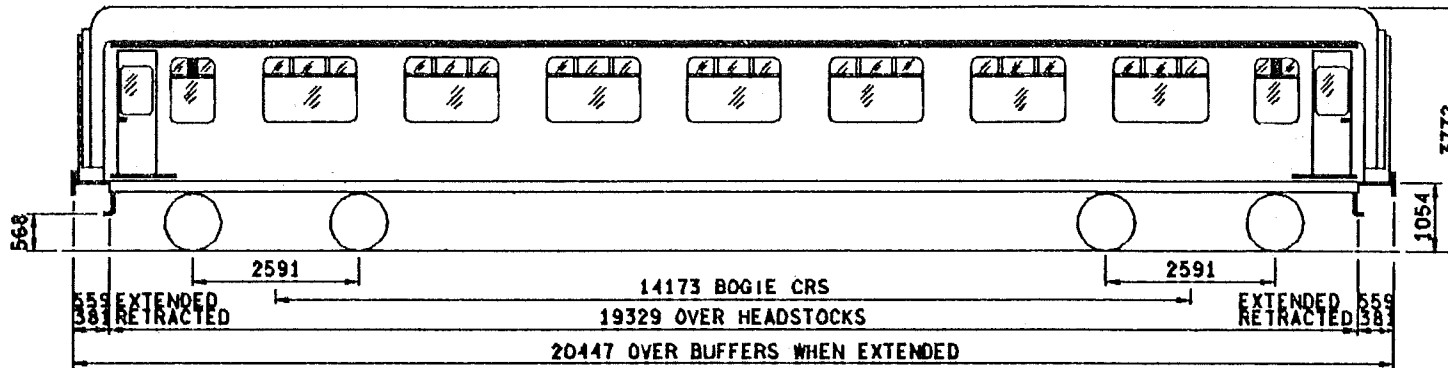

N.S. = NON SMOKING

- SEATS 18 FIRST 24 SECOND
- TOILETS 2
- COMPARTMENTS 7
- GUARDS COMPARTMENTS -
- VENTILATION PRESSURE
- CATERING EQUIPMENT -

ORIGINAL DIAGRAMS FOR REFERENCE:-
BR 122

ISSUE 3 DATE MAR '88

AA 303

BASIC TYPE

ALTERNATIVES

BRAKES
BOGIE/SUSPENSION
BODY CONSTRUCTION
COUPLINGS
TRAIN HEATING
E.T.H. INDEX
MAX. SPEED M.P.H.
MIN. RAD. CURVE CHAINS
LIGHTING
TARE WEIGHT TONNES
GANGWAYS
TRAIN COMMUNICATION
BUFFERS
BRAKE BLOCKS

AIR
B4
STEEL
AUTOMATIC DROPHEAD(BUCKEYE)
DUAL(STEAM/ELECTRIC(BR))WITH PRES SURE VENTILATION & HEATING
4
100
3.5
FLUORESCENT & TUNGSTEN
35
PULLMAN
NOT FITTED
RETRACTABLE SPINDLE(559X356 OVAL)
CAST IRON

TRACTION DATA FOR MULTIPLE UNITS

BASIC TYPE

AA 303 0A

VARIANTS

NONE

COMPOSITE CORRIDOR-MK 11C

CLASS ---

CK

AA 304

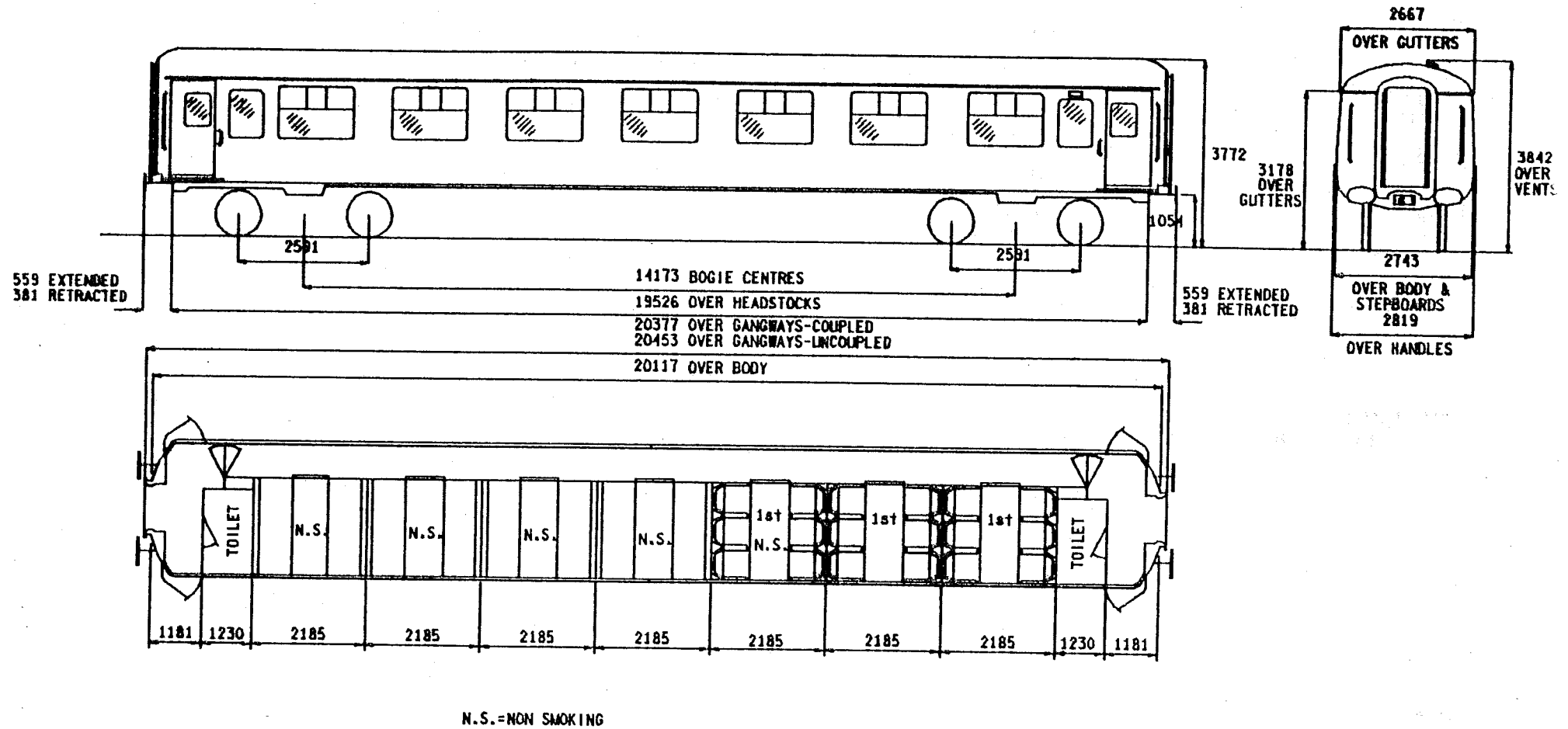

SEATS	18 FIRST 24 SECOND
TOILETS	2
COMPARTMENTS	7
GUARDS COMPARTMENTS	-
VENTILATION	PRESSURE
CATERING EQUIPMENT	-

ORIGINAL DIAGRAMS FOR REFERENCE:-
BR 125

ISSUE 2 DATE OCT '86

AA 304

BRAKES
 BOGIE/SUSPENSION
 BODY CONSTRUCTION
 COUPLINGS
 TRAIN HEATING
 E.T.H. INDEX
 MAX.SPEED M.P.H.
 MIN.RAD.CURVE CHAINS
 LIGHTING
 TARE WEIGHT TONNES
 GANGWAYS
 TRAIN COMMUNICATION
 BUFFERS
 BRAKE BLOCKS

BASIC TYPE

AIR
 B4
 STEEL
 AUTOMATIC DROPHEAD(BUCKEYE)
 DUAL(STEAM/ELECTRIC(BR))WITH PRESSURE VENTILATION & HEATING
 4
 100
 3.5
 FLUORESCENT & TUNGSTEN
 34
 PULLMAN
 NOT FITTED
 RETRACTABLE SPINDLE(559X356 OVAL)
 CAST IRON

ALTERNATIVES

COMPOSITION

TRACTION DATA FOR MULTIPLE UNITS

BASIC TYPE

AA 304 OA

VARIANTS

OB COMPOSITION BRAKE BLOCKS

BRAKE FIRST CORRIDOR-MK 1

CLASS ---

BFK

AB 101

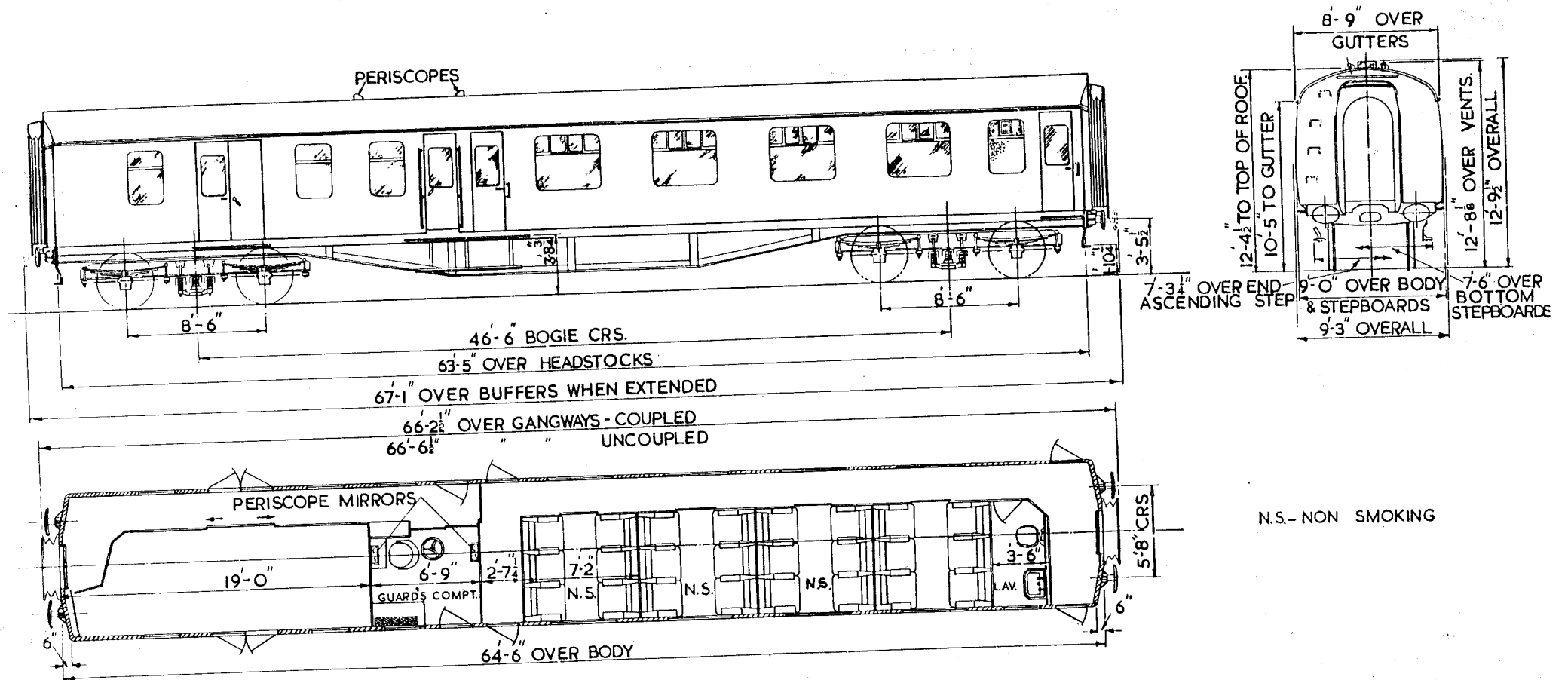

N.S. - NON SMOKING

SEATS	24
TOILETS	1
COMPARTMENTS	4
GUARDS COMPARTMENTS	1
VENTILATION	-
CATERING EQUIPMENT	-

ORIGINAL DIAGRAMS FOR REFERENCE:-
BR 161

ISSUE 6 DATE MAR 87

AB 101

BRAKES
 BOGIE/SUSPENSION
 BODY CONSTRUCTION
 COUPLINGS
 TRAIN HEATING
 E.T.H. INDEX
 MAX. SPEED M.P.H.
 MIN. RAD. CURVE CHAINS
 LIGHTING
 TARE WEIGHT TONNES
 GANGWAYS
 TRAIN COMMUNICATION
 BUFFERS
 BRAKE BLOCKS

BASIC TYPE

VACUUM
 B4
 STEEL
 AUTOMATIC DROPHEAD(BUCKEYE)
 STEAM
 -
 100
 3.5
 TUNGSTEN
 34
 PULLMAN
 NOT FITTED
 RETRACTABLE SPINDLE(559X356 OVAL)
 CAST IRON

ALTERNATIVES

AIR & VACUUM
 BR MK 1 LIGHT DOUBLE BOLSTER, COMMONWEALTH

DUAL(STEAM/ELECTRIC(BR))
 2
 90

FLUORESCENT & TUNGSTEN
 36

COMPOSITION

TRACTION DATA FOR MULTIPLE UNITSBASIC TYPE

AB 101 OA

VARIANTS

0C MAX. SPEED 90, BR MK 1 LIGHT DOUBLE BOLSTER BOGIES.
 1A DUAL HEATING(STEAM/ELECTRIC(BR)), E.T.H. 2.
 1B DUAL HEATING(STEAM/ELECTRIC(BR)), COMMONWEALTH BOGIES, E.T.H. 2, TARE 36.
 1C DUAL HEATING(STEAM/ELECTRIC(BR)), BR MK 1 LIGHT DOUBLE BOLSTER BOGIES, E.T.H. 2, MAX. SPEED 90.
 1D DUAL HEATING(STEAM/ELECTRIC(BR)), COMMONWEALTH BOGIES, E.T.H. 2, TARE 36, COMPOSITION BRAKE BLOCKS.
 1E DUAL HEATING(STEAM/ELECTRIC(BR)), BR MK 1 LIGHT DOUBLE BOLSTER BOGIES, E.T.H. 2, MAX. SPEED 90, COMPOSITION BRAKE BLOCKS.
 1F DUAL HEATING(STEAM/ELECTRIC(BR)), COMMONWEALTH BOGIES, E.T.H. 2, TARE 36, AIR & VACUUM BRAKES.
 1G DUAL HEATING(STEAM/ELECTRIC(BR)), COMMONWEALTH BOGIES, E.T.H. 2, TARE 36, COMPOSITION BRAKE BLOCKS, AIR & VACUUM BRAKES.
 2D DUAL HEATING(STEAM/ELECTRIC(BR)), COMMONWEALTH BOGIES, E.T.H. 2, TARE 36, COMPOSITION BRAKE BLOCKS, FLUORESCENT & TUNGSTEN LIGHTING.

BRAKE FIRST CORRIDOR-MK II

CLASS ---

BFK

AB 102

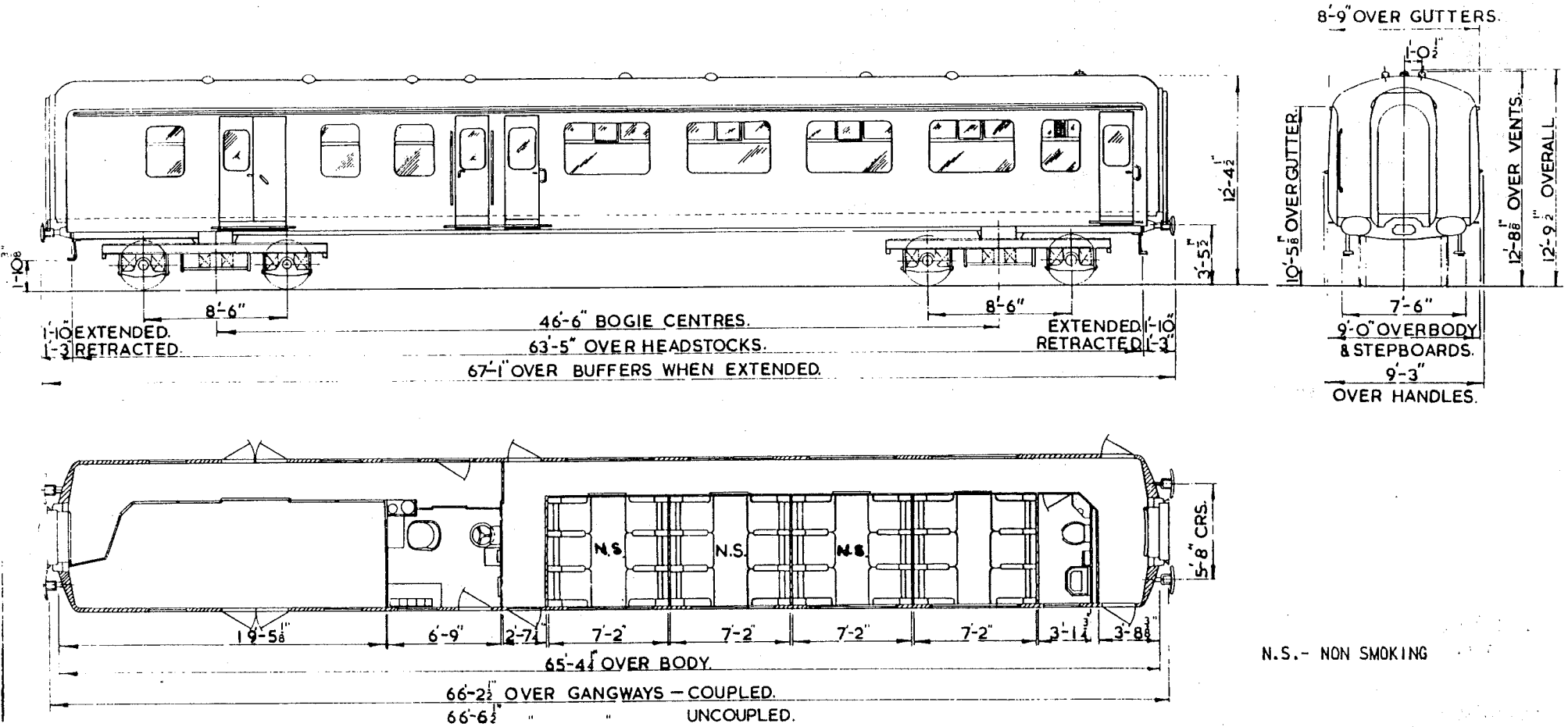

N.S. - NON SMOKING

- SEATS 24
- TOILETS 1
- COMPARTMENTS 4
- GUARDS COMPARTMENTS 1
- VENTILATION PRESSURE
- CATERING EQUIPMENT -

ORIGINAL DIAGRAMS FOR REFERENCE:-
BR 162

ISSUE 4 DATE NOV 87

AB 102

BRAKES
 BOGIE/SUSPENSION
 BODY CONSTRUCTION
 COUPLINGS
 TRAIN HEATING
 E.T.H. INDEX
 MAX.SPEED M.P.H.
 MIN.RAD.CURVE CHAINS
 LIGHTING
 TARE WEIGHT TONNES
 GANGWAYS
 TRAIN COMMUNICATION
 BUFFERS
 BRAKE BLOCKS

BASIC TYPE

VACUUM
 B4
 STEEL
 AUTOMATIC DROPHEAD(BUCKEYE)
 DUAL(STEAM/ELECTRIC(BR))WITH PRESSURE VENTILATION & HEATING
 4
 100
 3.5
 FLUORESCENT & TUNGSTEN
 32
 PULLMAN
 NOT FITTED
 RETRACTABLE SPINDLE(559X356 OVAL)
 CAST IRON

ALTERNATIVES

AIR

FITTED

COMPOSITION

TRACTION DATA FOR MULTIPLE UNITSBASIC TYPE

AB 102 DA

VARIANTS

0B COMPOSITION BRAKE BLOCKS.
 1C COMPOSITION BRAKE BLOCKS,AIR BRAKES,PUBLIC ADDRESS, TABLES ADDED FOR CHARTER TRAIN.

BRAKE FIRST CORRIDOR-MK 11A

CLASS ---

BFK

AB 103

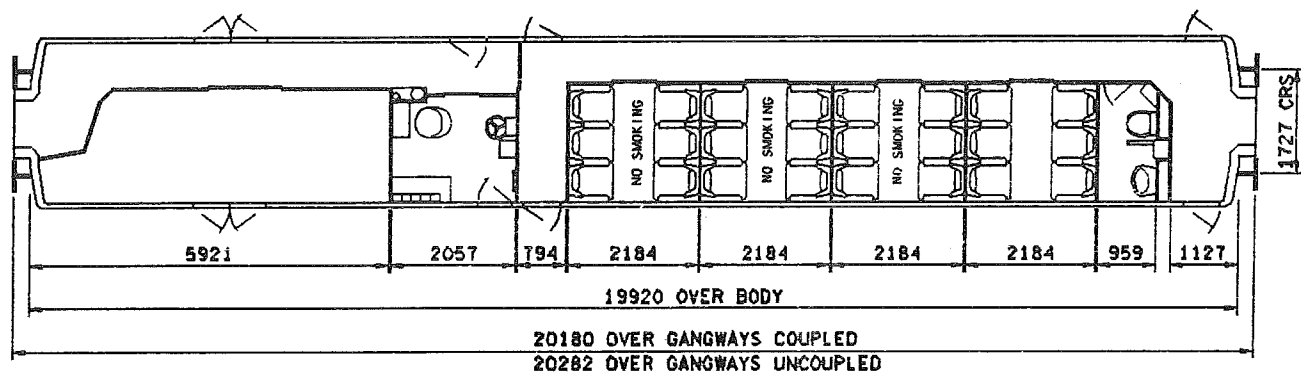
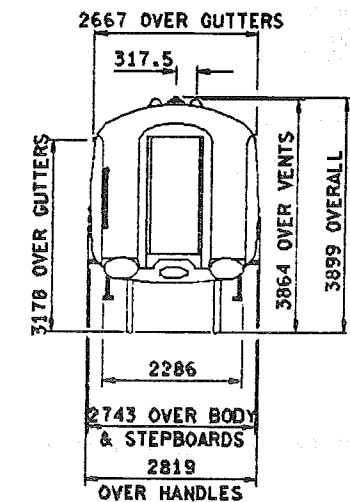
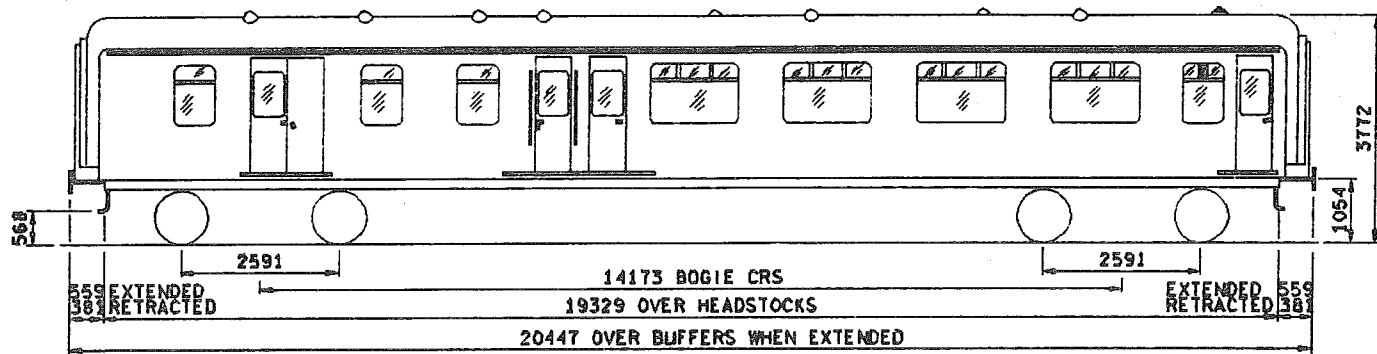

NS-NON SMOKING
SOME VEHICLES ALL SMOKING

SEATS	24
TOILETS	1
COMPARTMENTS	4
GUARDS COMPARTMENTS	1
VENTILATION	PRESSURE
CATERING EQUIPMENT	-

ORIGINAL DIAGRAMS FOR REFERENCE:-
BR 163

ISSUE 3
DATE JULY 1988

AB 103

BRAKES
 BOGIE/SUSPENSION
 BODY CONSTRUCTION
 COUPLINGS
 TRAIN HEATING
 E.T.H. INDEX
 MAX. SPEED M.P.H.
 MIN. RAD. CURVE CHAINS
 LIGHTING
 TARE WEIGHT TONNES
 GANGWAYS
 TRAIN COMMUNICATION
 BUFFERS

BASIC TYPE

AIR
 B4
 STEEL
 AUTOMATIC DROPHEAD(BUCKEYE)
 DUAL(STEAM/ELECTRIC(BR))WITH PRESSURE VENTILATION & HEATING
 4
 100
 3.5
 FLUORESCENT & TUNGSTEN
 32
 PULLMAN
 NOT FITTED
 RETRACTABLE SPINDLE(559X356 OVAL)

ALTERNATIVES

VACUUM

TRACTION DATA FOR MULTIPLE UNITSBASIC TYPE

AB 103 OA

VARIANTS

OB VACUUM BRAKES

OC VACUUM BRAKES, ALL COMPARTMENTS SMOKING

BRAKE FIRST CORRIDOR-MK IIB

CLASS ---

BFK

AB 104

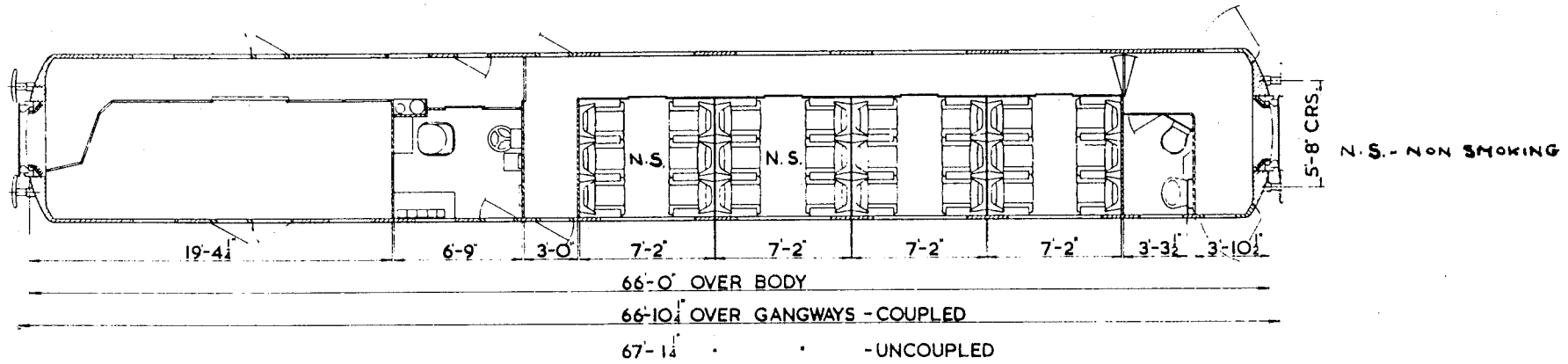
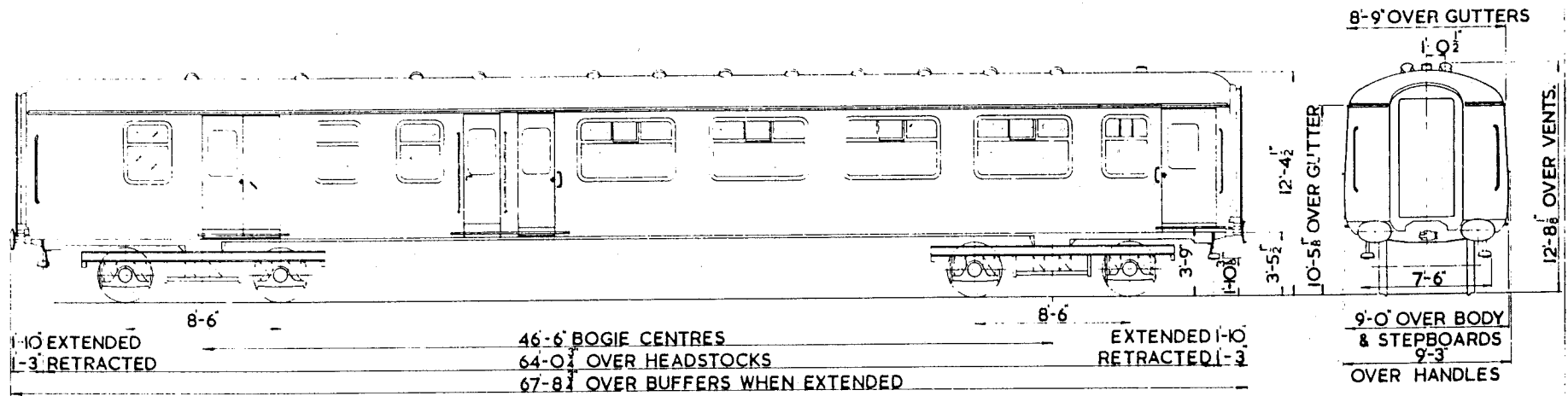

- SEATS 24
- TOILETS 1
- COMPARTMENTS 4
- GUARDS COMPARTMENTS 1
- VENTILATION PRESSURE
- CATERING EQUIPMENT -

ORIGINAL DIAGRAMS FOR REFERENCE.-
BR 164

ISSUE 1 DATE SEP '80

AB 104

BASIC TYPE

ALTERNATIVES

BRAKES
BOGIE/SUSPENSION
BODY CONSTRUCTION
COUPLINGS
TRAIN HEATING
E.T.H. INDEX
MAX. SPEED M.P.H.
MIN. RAD. CURVE CHAINS
LIGHTING
TARE WEIGHT TONNES
GANGWAYS
TRAIN COMMUNICATION
BUFFERS

AIR
B4
STEEL
AUTOMATIC DROPHEAD (BUCKEYE)
DUAL (STEAM/ELECTRIC (BR)) WITH PRESSURE VENTILATION & HEATING
4
100
3.5
FLUORESCENT & TUNGSTEN
32
PULLMAN
NOT FITTED
RETRACTABLE SPINDLE (559X356 OVAL)

TRACTION DATA FOR MULTIPLE UNITS

BASIC TYPE

AB 104 0A

VARIANTS

NONE

BRAKE FIRST CORRIDOR-MK IIC

CLASS ---

BFK

AB 105

VENTS TYPE 'G' OR 'GM' FOR VEHICLE Nos M14113-M14128
VENTS TYPE 'ROEVAC' TW50 FOR VEHICLE Nos M14129-M14138

WINDOWS DRG No SC/SW 2814 FOR VEHICLE Nos M14113-M14128
WINDOWS DRG No C-AO-1115 FOR VEHICLE Nos M14129-M14138

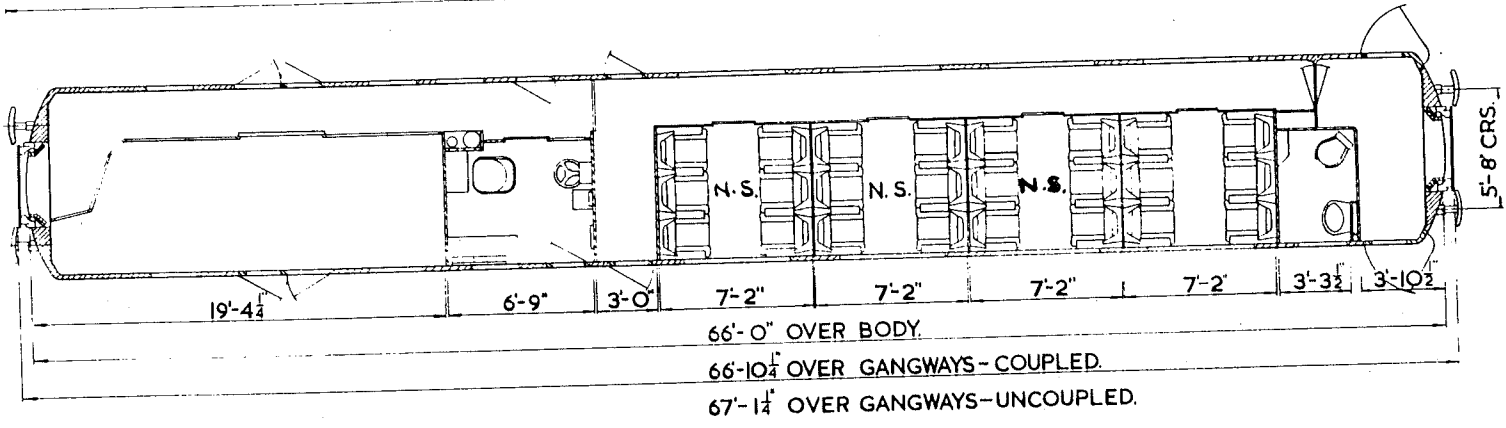
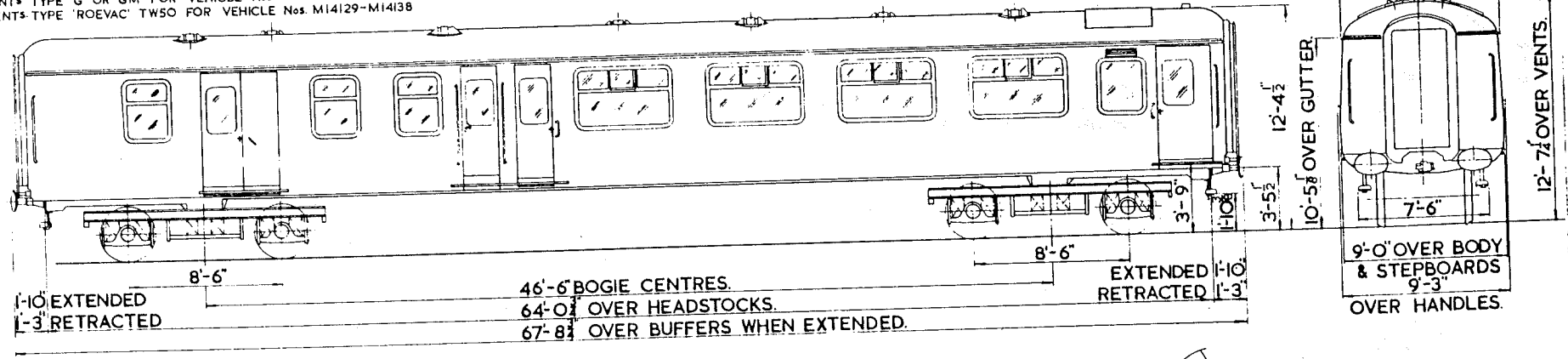

SEATS	24
TOILETS	1
COMPARTMENTS	4
GUARDS COMPARTMENTS	1
VENTILATION	PRESSURE
CATERING EQUIPMENT	-

ORIGINAL DIAGRAMS FOR REFERENCE.-
BR 165

ISSUE 2
DATE OCT '81

AB 105

BASIC TYPE

AIR
 B4
 STEEL
 AUTOMATIC DROPHEAD (BUCKEYE)
 DUAL (STEAM/ELECTRIC (BR)) WITH PRESSURE VENTILATION & HEATING
 4
 100
 3.5
 FLUORESCENT & TUNGSTEN
 32
 PULLMAN
 NOT FITTED
 RETRACTABLE SPINDLE (559X356 OVAL)
 CAST IRON

ALTERNATIVES

PUBLIC ADDRESS WITH TRANSMITTER
 COMPOSITION

BRAKES
 BOGIE/SUSPENSION
 BODY CONSTRUCTION
 COUPLINGS
 TRAIN HEATING
 E.T.H. INDEX
 MAX. SPEED M.P.H.
 MIN. RAD. CURVE CHAINS
 LIGHTING
 TARE VEIGHT TONNES
 GANGWAYS
 TRAIN COMMUNICATION
 BUFFERS
 BRAKE BLOCKS

TRACTION DATA FOR MULTIPLE UNITS

BASIC TYPE

AB 105 0A

VARIANTS

- 0B COMPOSITION BRAKE BLOCKS.
- 1A PUBLIC ADDRESS WITH TRANSMITTER.
- 1B PUBLIC ADDRESS WITH TRANSMITTER, COMPOSITION BRAKE BLOCKS.

BRAKE FIRST CORRIDOR-MK IID

CLASS ---

BFK

AB 106

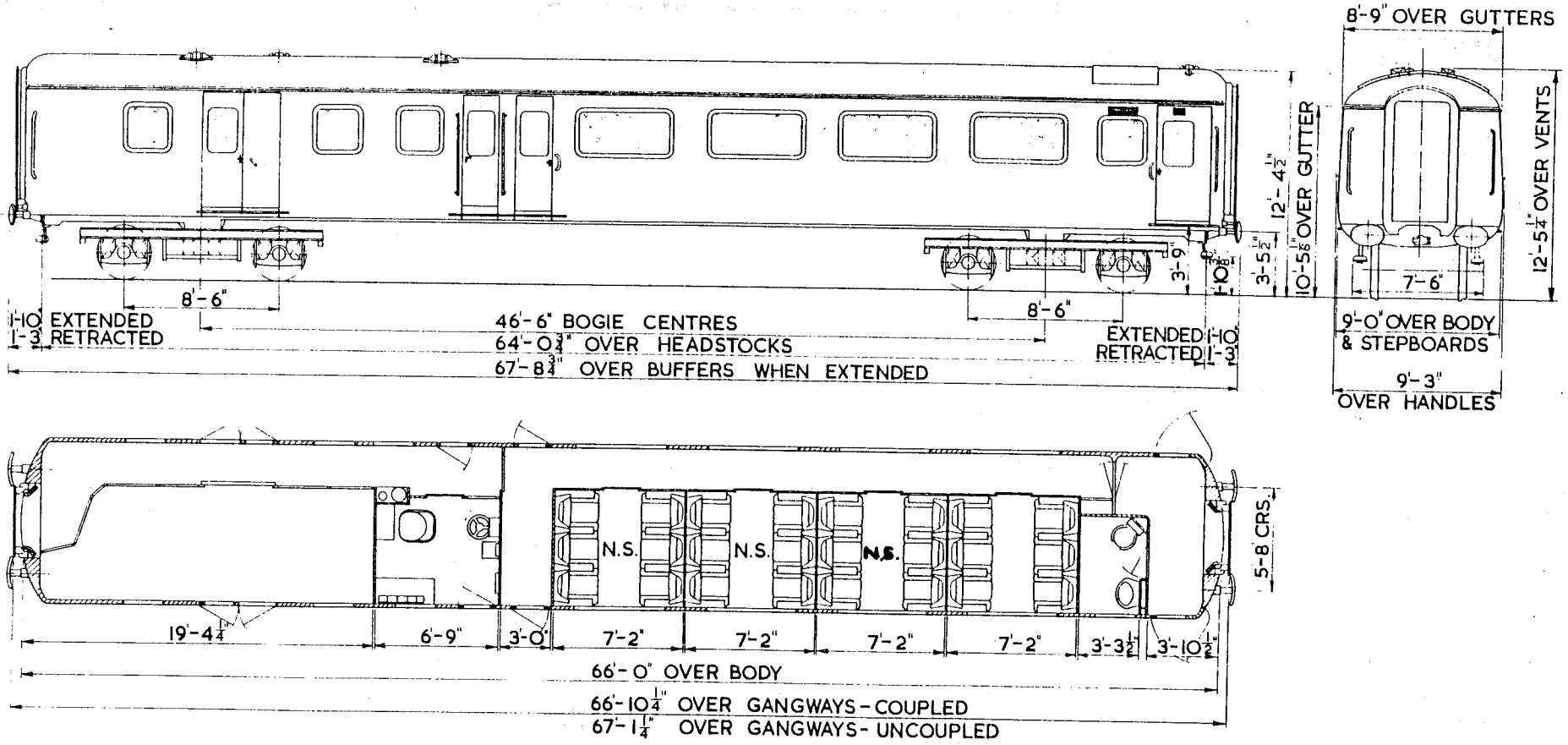

- SEATS 24
- TOILETS 1
- COMPARTMENTS 4
- GUARDS COMPARTMENTS 1
- VENTILATION FULL AIR CONDITIONING
- CATERING EQUIPMENT -

ORIGINAL DIAGRAMS FOR REFERENCE:-
BR 166

ISSUE 4 DATE MAR 87

AB 106

BASIC TYPE

BRAKES
BOGIE/SUSPENSION
BODY CONSTRUCTION
COUPLINGS
TRAIN HEATING
E.T.H. INDEX
MAX. SPEED M.P.H.
MIN. RAD. CURVE CHAINS
LIGHTING
TARE WEIGHT TONNES
GANGWAYS
TRAIN COMMUNICATION
BUFFERS

AIR
B4
STEEL
AUTOMATIC DROPHEAD(BUCKEYE)
ELECTRIC(BR) FULL AIR CONDITIONING (NOT SUITED TO CLASS 55 LOCOS)
5
100
3.5
FLUORESCENT & TUNGSTEN
33
PULLMAN
PUBLIC ADDRESS WITH TRANSMITTER
RETRACTABLE SPINDLE(559X356 OVAL)

ALTERNATIVES

ELECTRIC(BR)FULL AIR CONDITIONING

PUBLIC ADDRESS WITH TRANSMITTER, DRIVER GUARD

TRACTION DATA FOR MULTIPLE UNITS

BASIC TYPE

AB 106 OA

VARIANTS

- 1A ELECTRIC(BR)FULL AIR CONDITIONING.
- 2A DRIVER GUARD COMMUNICATION FITTED.
- 3A ELECTRIC(BR)FULL AIR CONDITIONING, DRIVER GUARD COMMUNICATION FITTED.

BRAKE SECOND CORRIDOR MK 1

CLASS ---

BSK

AB 201

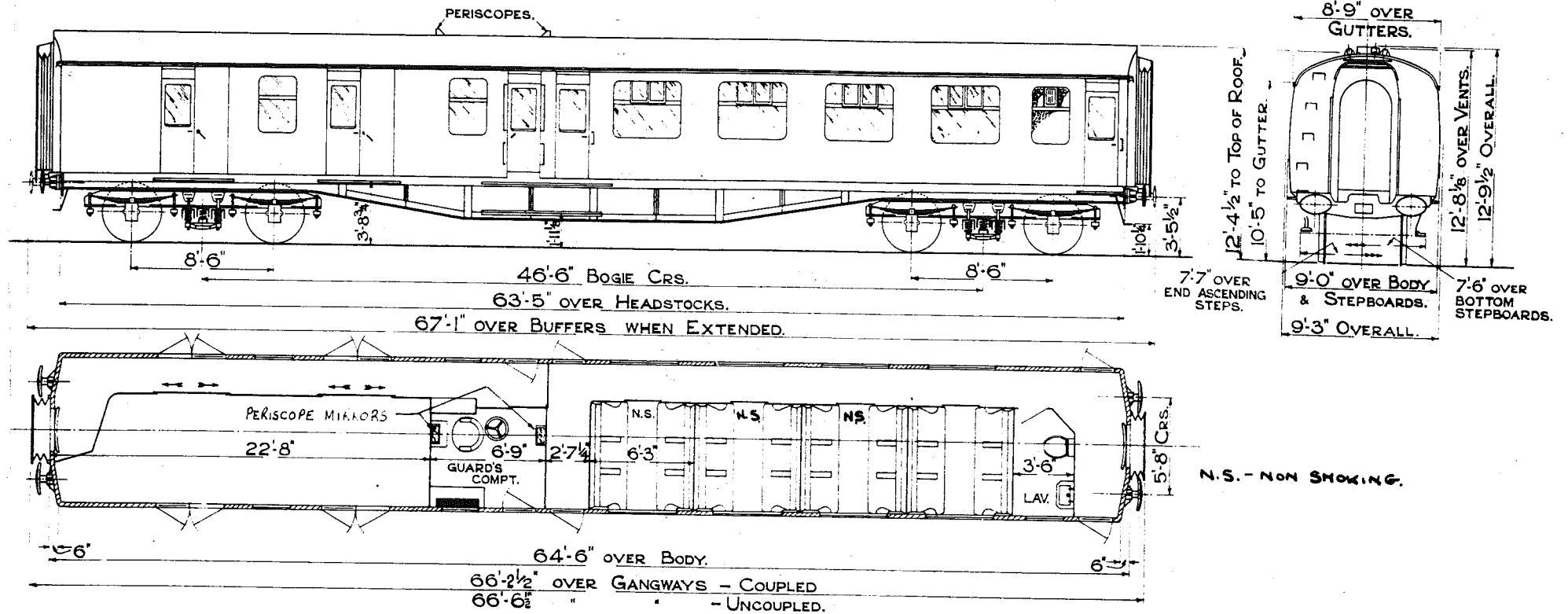

SEATS	24
TOILETS	1
COMPARTMENTS	4
GUARDS COMPARTMENTS	1
VENTILATION	-
CATERING EQUIPMENT	-

ORIGINAL DIAGRAMS FOR REFERENCE:-
BR 181

ISSUE 6 DATE MAR 89

AB 201

BRAKES
 BOGIE/SUSPENSION
 BODY CONSTRUCTION
 COUPLINGS
 TRAIN HEATING
 E.T.H. INDEX
 MAX.SPEED M.P.H.
 MIN.RAD.CURVE CHAINS
 LIGHTING
 TARE WEIGHT TONNES
 GANGWAYS
 TRAIN COMMUNICATION
 BUFFERS

BASIC TYPE

VACUUM
 COMMONWEALTH
 STEEL
 AUTOMATIC DROPHEAD(BUCKEYE)
 STEAM
 -
 100
 3.5
 TUNGSTEN
 37
 PULLMAN
 NOT FITTED
 RETRACTABLE SPINDLE(559X356 OVAL)

ALTERNATIVES

B4,BR MK I LIGHT DOUBLE BOLSTER

DUAL(STEAM/ELECTRIC(BR))

2
90

FLUORESCENT & TUNGSTEN

34

FITTED

TRACTION DATA FOR MULTIPLE UNITSBASIC TYPE

AB 201 OA

VARIANTS

OB B4 BOGIES,TARE 34.

OC BR MK I LIGHT DOUBLE BOLSTER BOGIES,MAX.SPEED 90,TARE 34.

1A DUAL HEATING(STEAM/ELECTRIC(BR)),E.T.H.2.

1B DUAL HEATING(STEAM/ELECTRIC(BR)),E.T.H.2,B4 BOGIES,TARE 34.

1C DUAL HEATING(STEAM/ELECTRIC(BR)),E.T.H.2,BR MK I LIGHT DOUBLE BOLSTER BOGIES,TARE 34,MAX.SPEED 90.

1D DUAL HEATING(STEAM/ELECTRIC(BR)),E.T.H.2,BR MK I LIGHT DOUBLE BOLSTER BOGIES,TARE 34,MAX.SPEED 90,50% NON-SMOKING.

2A DUAL HEATING(STEAM/ELECTRIC(BR)),FLUORESCENT & TUNGSTEN LIGHTING,E.T.H.2.

2C DUAL HEATING(STEAM/ELECTRIC(BR)),FLUORESCENT & TUNGSTEN LIGHTING,E.T.H.2,BR MK I LIGHT DOUBLE BOLSTER BOGIES,TARE 34,MAX.SPEED 90.

3A DUAL HEATING(STEAM/ELECTRIC(BR)),P.A.FITTED,E.T.H.2.

3B DUAL HEATING(STEAM/ELECTRIC(BR)),P.A.FITTED,E.T.H.2,B4 BOGIES,TARE 34.

BRAKE SECOND CORRIDOR MK 1

CLASS ---

BSK

4B 201

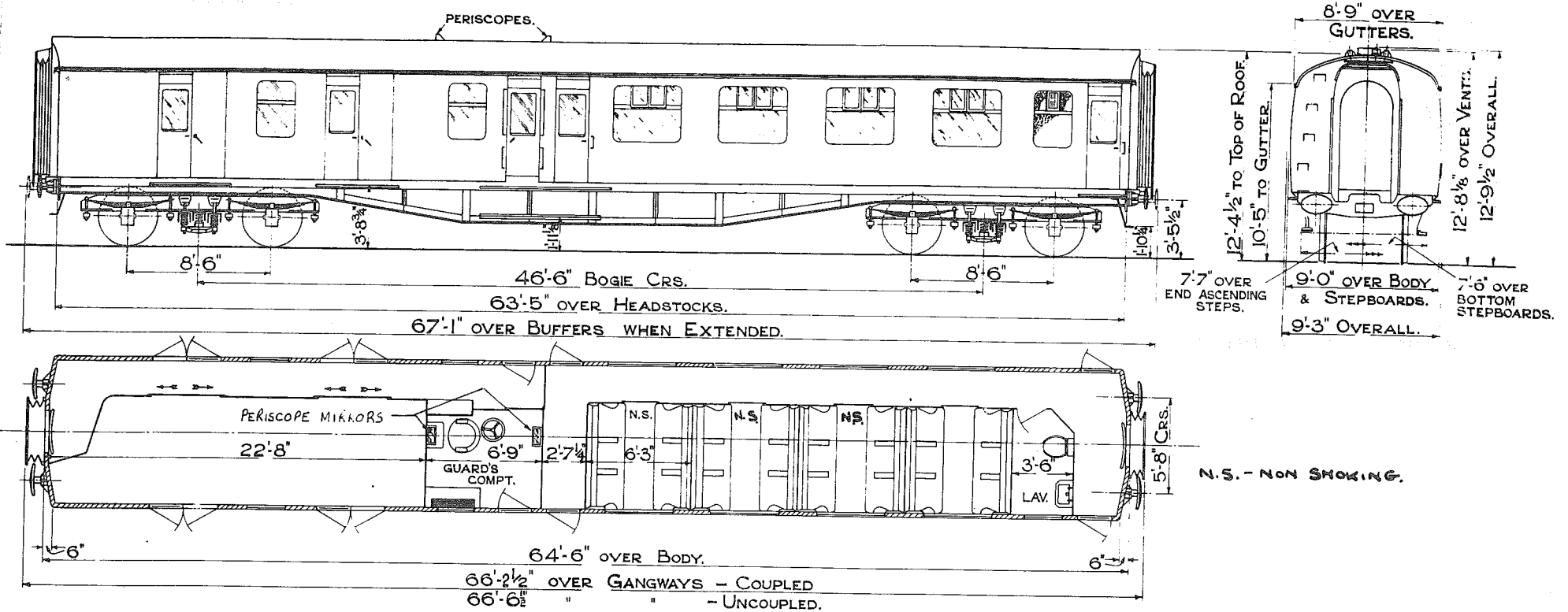

SEATS	24
TOILETS	1
COMPARTMENTS	4
GUARDS COMPARTMENTS	1
VENTILATION	-
CATERING EQUIPMENT	-

ORIGINAL DIAGRAMS FOR REFERENCE:-
BR 181

ISSUE 5 DATE DEC 88

AB 201

BRAKES
BOGIE/SUSPENSION
BODY CONSTRUCTION
COUPLINGS
TRAIN HEATING
E.T.H. INDEX
MAX. SPEED M.P.H.
MIN. RAD. CURVE CHAINS
LIGHTING
TARE WEIGHT TONNES
GANGWAYS
TRAIN COMMUNICATION
BUFFERS

BASIC TYPE

VACUUM
COMMONWEALTH
STEEL
AUTOMATIC DROPHEAD(BUCKEYE)
STEAM
-
100
3.5
TUNGSTEN
37
PULLMAN
NOT FITTED
RETRACTABLE SPINDLE(559X356 OVAL)

ALTERNATIVES

B4.BR MK I LIGHT DOUBLE BOLSTER

DUAL (STEAM/ELECTRIC(BR))

2

90

FLUORESCENT & TUNGSTEN

34

TRACTION DATA FOR MULTIPLE UNITSBASIC TYPE

AB 201 0A

VARIANTS

OB B4 BOGIES, TARE 34.
OC BR MKI LIGHT DOUBLE BOLSTER BOGIES, MAX. SPEED 90, TARE 34.
1A DUAL HEATING(STEAM/ELECTRIC(BR)), E.T.H.2.
1B DUAL HEATING(STEAM/ELECTRIC(BR)), E.T.H.2, B4 BOGIES, TARE 34.
1C DUAL HEATING(STEAM/ELECTRIC(BR)), E.T.H.2, BR MKI LIGHT DOUBLE BOLSTER BOGIES, TARE 34, MAX. SPEED 90.
1D DUAL HEATING(STEAM/ELECTRIC(BR)), E.T.H.2, BR MKI LIGHT DOUBLE BOLSTER BOGIES, TARE 34, MAX. SPEED 90, 50% NON-SMOKING.
2A DUAL HEATING(STEAM/ELECTRIC(BR)), FLUORESCENT & TUNGSTEN LIGHTING, E.T.H.2.
2C DUAL HEATING(STEAM/ELECTRIC(BR)), FLUORESCENT & TUNGSTEN LIGHTING, E.T.H.2, BR MKI LIGHT DOUBLE BOLSTER BOGIES, TARE 34, MAX. SPEED 90.

BRAKE SECOND CORRIDOR-MK 1

CLASS ---

BSK

AB 202

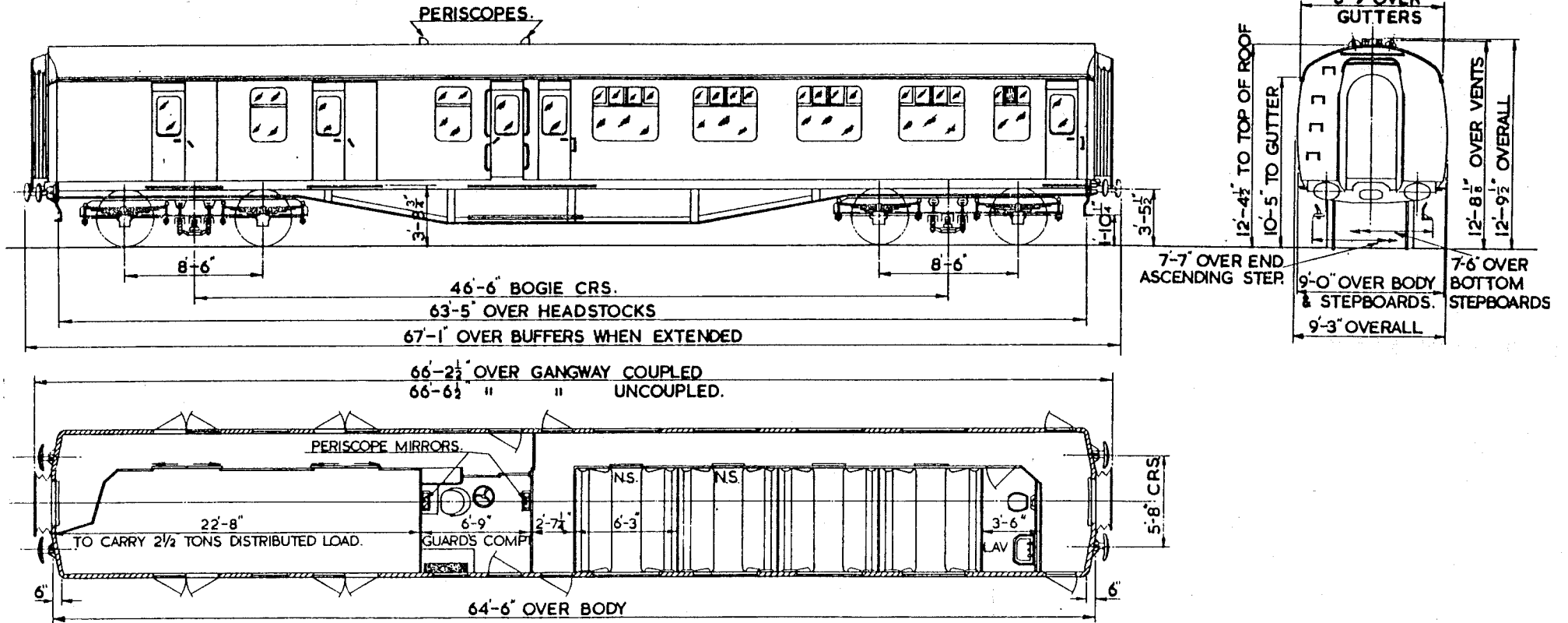

SEATS	32
TOILETS	1
COMPARTMENTS	4
GUARDS COMPARTMENTS	1
VENTILATION	-
CATERING EQUIPMENT	-

ORIGINAL DIAGRAMS FOR REFERENCE:-
BR 182

ISSUE 5 DATE OCT 86

AB 202

BASIC TYPE

BRAKES
BOGIE/SUSPENSION
BODY CONSTRUCTION
COUPLINGS
TRAIN HEATING

E.T.H. INDEX
MAX. SPEED M.P.H.
MIN. RAD. CURVE CHAINS
LIGHTING
TARE WEIGHT TONNES
GANGWAYS
TRAIN COMMUNICATION
BUFFERS
BEARINGS

VACUUM
COMMONWEALTH
STEEL
AUTOMATIC DROPHEAD (BUCKEYE)
STEAM

-
100
3.5
TUNGSTEN
35
PULLMAN
NOT FITTED
RETRACTABLE SPINDLE (559X356 OVAL)
OIL

ALTERNATIVES

AIR
BR MK 1 LIGHT DOUBLE BOLSTER, B4

DUAL (STEAM/ELECTRIC (BR)), DUAL (STEAM/ELECTRIC (BR/UIC)),
ELECTRIC (BR)
2,2 WITH 675 VOLT HEATERS
90

FLUORESCENT & TUNGSTEN
34, 37

ROLLER

TRACTION DATA FOR MULTIPLE UNITSBASIC TYPE

AB 202 OA

VARIANTS

OB B4 BOGIES, TARE 34.
OC BR MK 1 LIGHT DOUBLE BOLSTER BOGIES, MAX. SPEED 90.
1B B4 BOGIES, DUAL HEATING (STEAM/ELECTRIC (BR)), E.T.H. 2, TARE 34.
1C BR MK 1 LIGHT DOUBLE BOLSTER BOGIES, MAX. SPEED 90, DUAL HEATING (STEAM/ELECTRIC (BR)), E.T.H. 2, TARE 34.
1D DUAL HEATING (STEAM/ELECTRIC (BR)), E.T.H. 2, TARE 37.
1H BR MK 1 LIGHT DOUBLE BOLSTER BOGIES, MAX. SPEED 90, DUAL HEATING (STEAM/ELECTRIC (BR)), E.T.H. 2, TARE 34, ROLLER BEARINGS.
2C BR MK 1 LIGHT DOUBLE BOLSTER BOGIES, MAX. SPEED 90, DUAL HEATING (STEAM/ELECTRIC (BR/UIC)), E.T.H. 2, TARE 34.
3E ELECTRIC (BR) HEATING, AIR BRAKES, E.T.H. 2 WITH 675 VOLT HEATERS, TARE 33, MAX. SPEED 90.
4C DUAL HEATING (STEAM/ELECTRIC (BR)), BR MK 1 LIGHT DOUBLE BOLSTER BOGIES, E.T.H. 2 WITH 675 VOLT HEATERS, MAX. SPEED 90, TARE 34.
5C DUAL HEATING (STEAM/ELECTRIC (BR/UIC)), BR MK 1 LIGHT DOUBLE BOLSTER BOGIES, E.T.H. 2 WITH 675 VOLT HEATERS, MAX. SPEED 90, TARE 34.
6B B4 BOGIES, FLUORESCENT & TUNGSTEN, DUAL HEATING (STEAM/ELECTRIC (BR)), E.T.H. 2, TARE 34.
6D DUAL HEATING (STEAM/ELECTRIC (BR)), E.T.H. 2, TARE 37, FLUORESCENT & TUNGSTEN.
6H BR MK 1 LIGHT DOUBLE BOLSTER BOGIES, MAX. SPEED 90, DUAL HEATING (STEAM/ELECTRIC (BR)), E.T.H. 2, TARE 34, ROLLER BEARINGS, FLUORESCENT & TUNGSTEN.

BRAKE SECOND CORRIDOR-MK 1

CLASS ---

BSK

AB 203

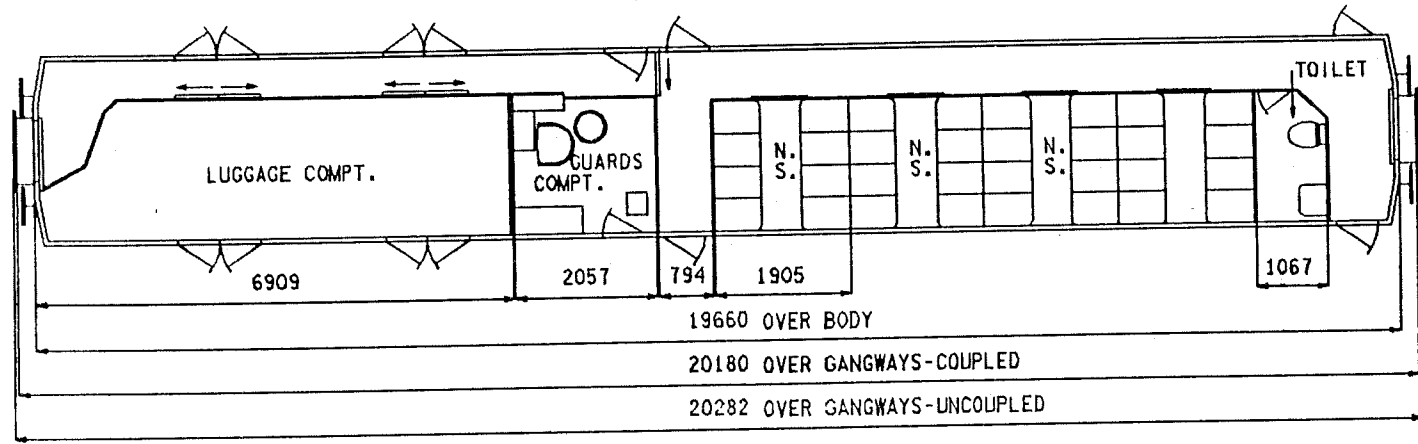
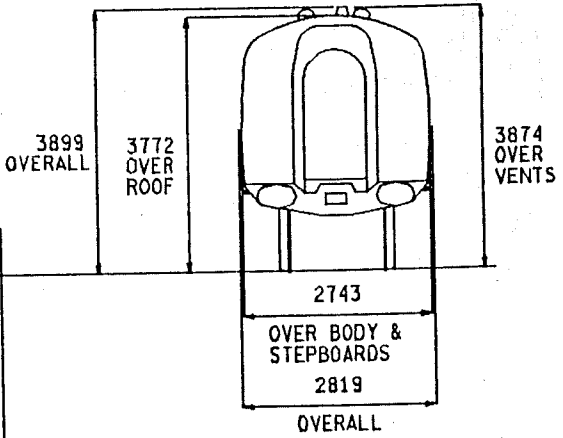
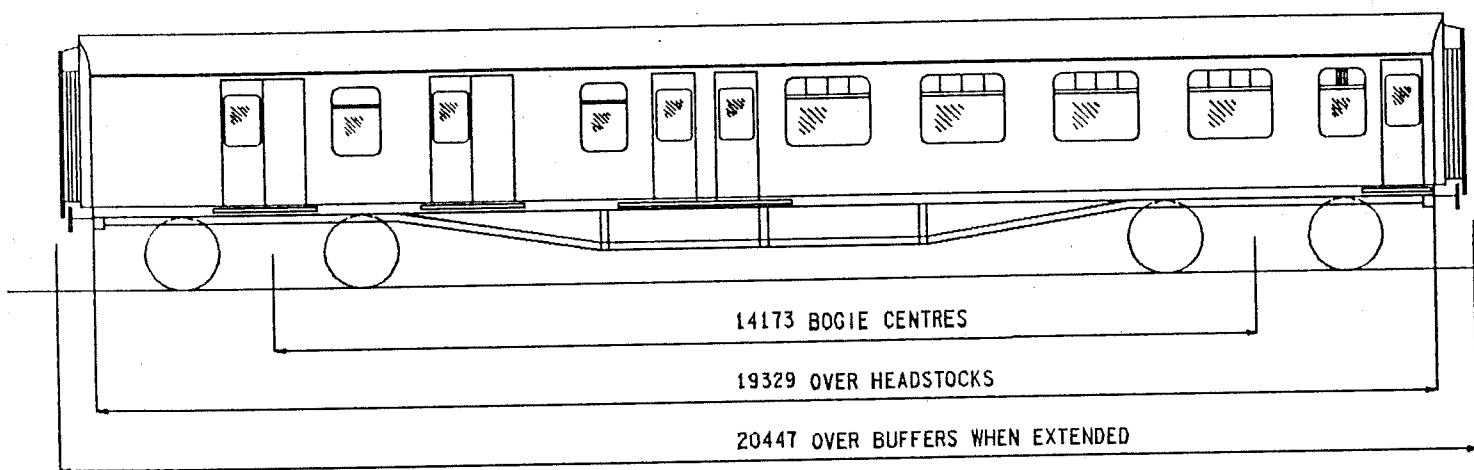

N.S. - NON SMOKING

SEATS	32
TOILETS	1
COMPARTMENTS	4
GUARDS COMPARTMENTS	1
VENTILATION	-
CATERING EQUIPMENT	-

ISSUE 2 DATE AUG '82

AB 203

BRAKES
 BOGIE/SUSPENSION
 BODY CONSTRUCTION
 COUPLINGS
 TRAIN HEATING
 E.T.H. INDEX
 MAX.SPEED M.P.H.
 MIN.RAD.CURVE CHAINS
 LIGHTING
 TARE WEIGHT TONNES
 GANGWAYS
 TRAIN COMMUNICATION
 BUFFERS

BASIC TYPE

VACUUM
 BR MK 1 LIGHT DOUBLE BOLSTER
 STEEL
 AUTOMATIC DROPHEAD(BUCKEYE)
 DUAL(STEAM/ELECTRIC(BR))
 2
 90
 3.5
 TUNGSTEN
 34
 PULLMAN
 NOT FITTED
 RETRACTABLE SPINDLE(559X356 OVAL)

ALTERNATIVES

TRACTION DATA FOR MULTIPLE UNITS

BASIC TYPE

AB 203 0A

VARIANTS

NONE

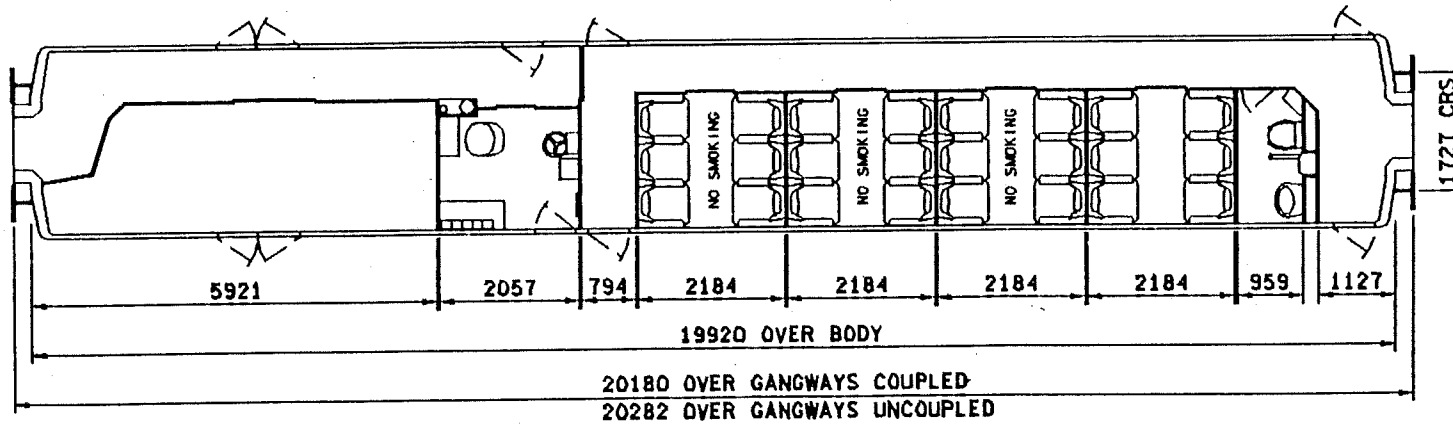
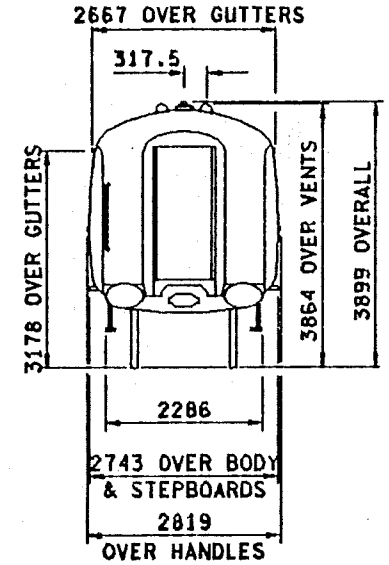
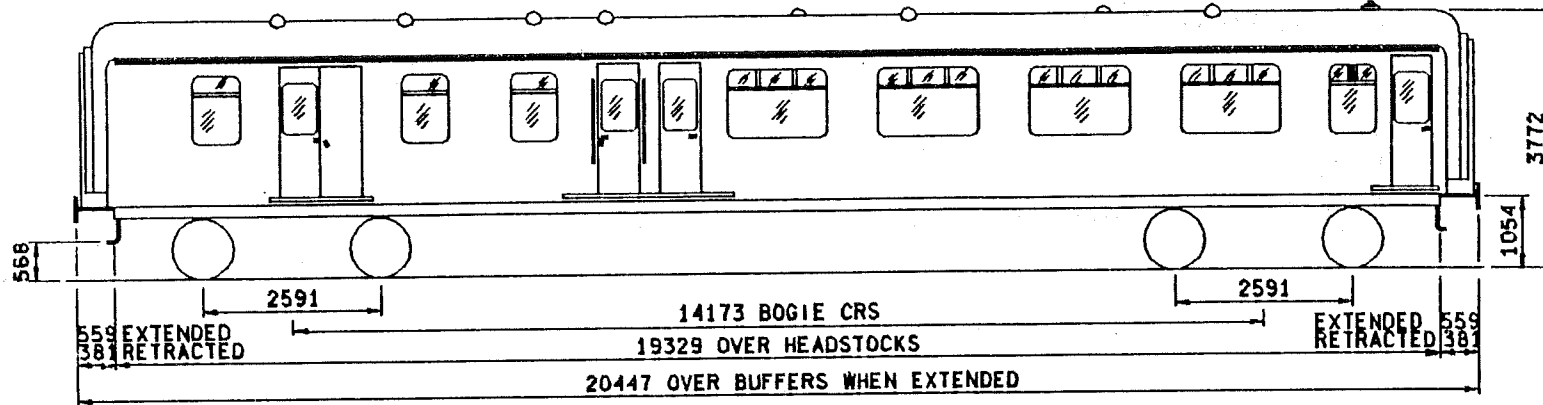

SOME VEHICLES ALL SMOKING

SEATS	24
TOILETS	1
COMPARTMENTS	4
GUARDS COMPARTMENTS	1
VENTILATION	PRESSURE
CATERING EQUIPMENT	-

ISSUE 3
DATE APR 87

AB 204

BASIC TYPE

ALTERNATIVES

BRAKES
BOGIE/SUSPENSION
BODY CONSTRUCTION
COUPLINGS
TRAIN HEATING
E.T.H. INDEX
MAX. SPEED M.P.H.
MIN. RAD. CURVE CHAINS
LIGHTING
TARE WEIGHT TONNES
GANGWAYS
TRAIN COMMUNICATION
BUFFERS

VACUUM
B4
STEEL
AUTOMATIC DROPHEAD(BUCKEYE)
DUAL(STEAM/ELECTRIC(BR)) WITH PRESSURE VENTILATION & HEATING
4
100
3.5
FLUORESCENT & TUNGSTEN
32
PULLMAN
NOT FITTED
RETRACTABLE SPINDLE(559X356 OVAL)

AIR

TRACTION DATA FOR MULTIPLE UNITS

BASIC TYPE

AB 204 OA

VARIANTS

OB AIR BRAKES
OC ALL COMPARTMENTS SMOKING.

BRAKE COMPOSITE CORRIDOR-MK I

CLASS ---

BCK

AB 301

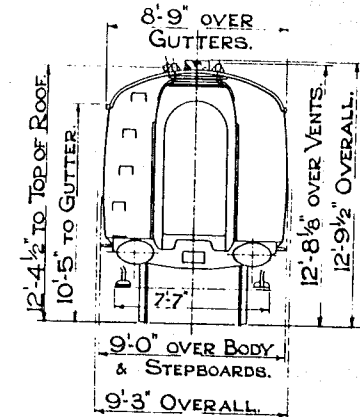
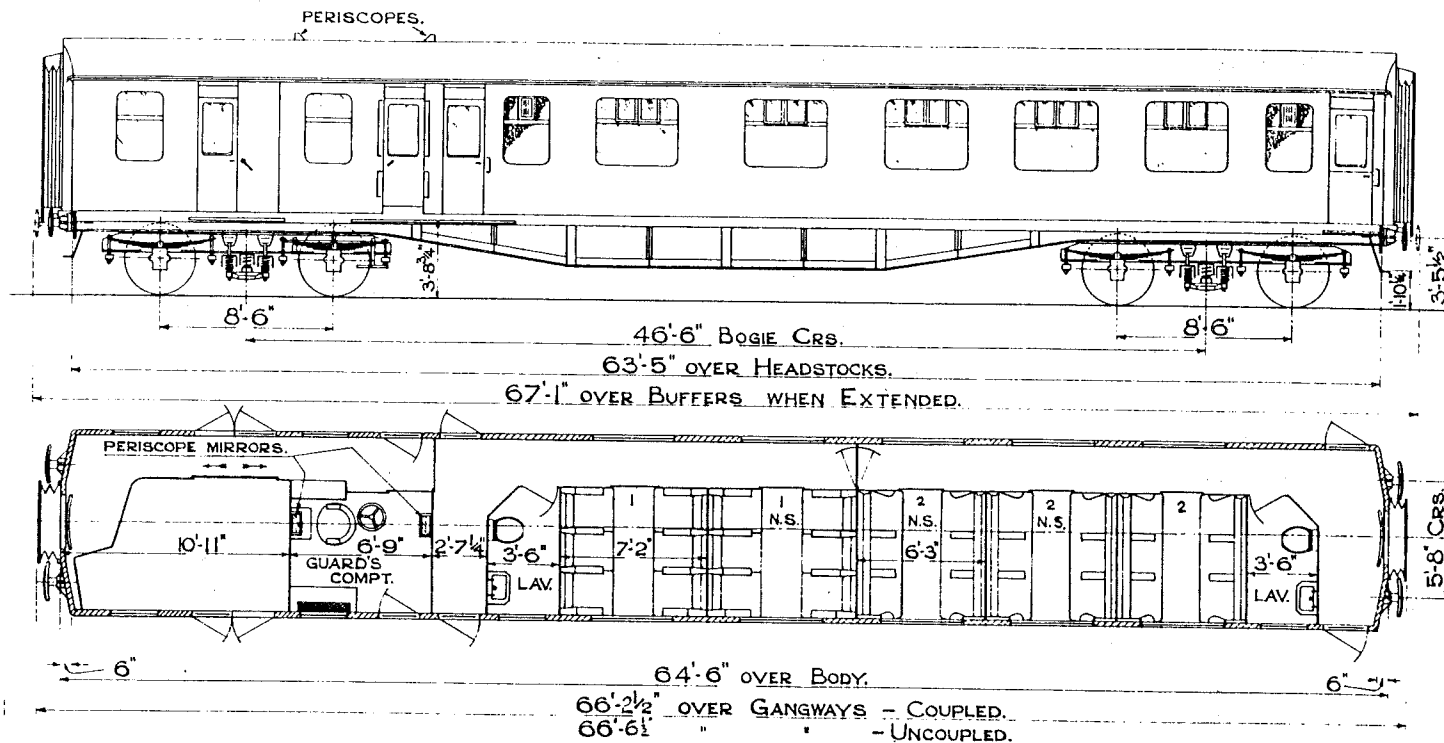

- | | |
|----------------------|---------------------------------|
| SEATS | 12 FIRST CLASS, 18 SECOND CLASS |
| TOILETS | 2 |
| COMPARTMENTS | 2 FIRST CLASS, 3 SECOND CLASS |
| GUARD'S COMPARTMENTS | 1 |
| VENTILATION | - |
| CATERING EQUIPMENT | - |

N.S. - NON SMOKING

ORIGINAL DIAGRAMS FOR REFERENCE:-
BR 171

ISSUE 2 DATE NOV 87

AB 301

BRAKES
BOGIE/SUSPENSION
BODY CONSTRUCTION
COUPLINGS
TRAIN HEATING
E.T.H. INDEX
MAX.SPEED M.P.H.
MIN.RAD.CURVE CHAINS
LIGHTING
TARE WEIGHT TONNES
GANGWAYS
TRAIN COMMUNICATION
BUFFERS

BASIC TYPE

VACUUM
COMMONWEALTH
STEEL
AUTOMATIC DROPHEAD(BUCKEYE)
STEAM
-
100
3.5
TUNGSTEN
36
PULLMAN
NOT FITTED
RETRACTABLE SPINDLE(559X356 OVAL)

ALTERNATIVES

VACUUM & AIR
B4,BR MK 1 LIGHT DOUBLE BOLSTER

DUAL(STEAM/ELECTRIC(BR))

3
90

35,34

FITTED

TRACTION DATA FOR MULTIPLE UNITSBASIC TYPE

AB 301 OA

VARIANTS

OB B4 BOGIES,TARE 35.
OC BR MK 1 LIGHT DOUBLE BOLSTER BOGIES,MAX.SPEED 90,TARE 34.
1A DUAL HEATING(STEAM/ELECTRIC(BR)),E.T.H.3.
1C DUAL HEATING(STEAM/ELECTRIC(BR)),BR MK 1 LIGHT DOUBLE BOLSTER BOGIES,E.T.H.3,MAX.SPEED 90,TARE 34.
2D DUAL HEATING(STEAM/ELECTRIC(BR)),E.T.H.3,DUAL BRAKED,PUBLIC ADDRESS,COMPOSITION BRAKE BLOCKS,FOR CHARTER TRAIN.

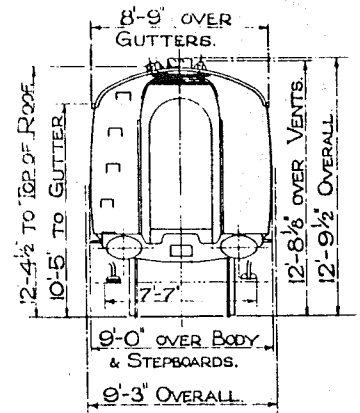
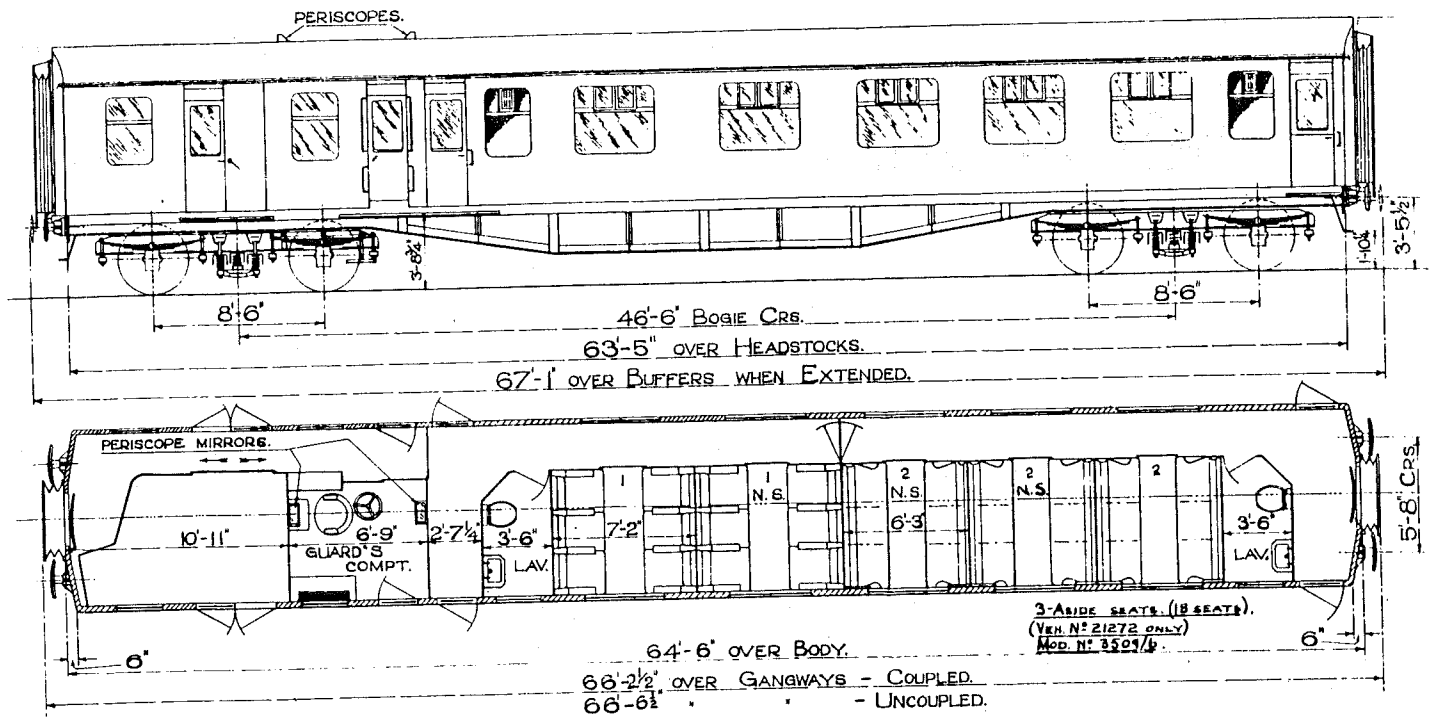

N.S. - NON SMOKING.

SEATS
TOILETS
COMPARTMENTS
GUARDS COMPARTMENTS
VENTILATION
CATERING EQUIPMENT

SEE VARIANTS
2
2 FIRST CLASS, 3 SECOND CLASS
1
-
-

ORIGINAL DIAGRAMS FOR REFERENCE:-
BR 172A

ISSUE 5 DATE MAR 87

AB 302

BRAKES
 BOGIE/SUSPENSION
 BODY CONSTRUCTION
 COUPLINGS
 TRAIN HEATING
 E.T.H. INDEX
 MAX. SPEED M.P.H.
 MIN. RAD. CURVE CHAINS
 LIGHTING
 TARE WEIGHT TONNES
 GANGWAYS
 TRAIN COMMUNICATION
 BUFFERS
 SEATS

BASIC TYPE

VACUUM
 B4
 STEEL
 AUTOMATIC DROPHEAD (BUCKEYE)
 STEAM
 -
 100
 3.5
 TUNGSTEN
 34
 PULLMAN
 NOT FITTED
 RETRACTABLE SPINDLE (559X356 OVAL)
 12 FIRST CLASS 24 SECOND CLASS

ALTERNATIVES

AIR
 BR MK 1 LIGHT DOUBLE BOLSTER, COMMONWEALTH

 DUAL (STEAM/ELECTRIC (BR)), ELECTRIC (BR/UIC)
 3
 90

 FLUORESCENT & TUNGSTEN LIGHTING
 33, 36

 12 FIRST CLASS 18 SECOND CLASS

TRACTION DATA FOR MULTIPLE UNITSBASIC TYPE

AB 302 OA

VARIANTS

- 1B COMMONWEALTH BOGIES, E.T.H.3, TARE 36, DUAL HEATING (STEAM/ELECTRIC (BR)), 12 FIRST CLASS & 18 SECOND CLASS SEATS.
 1D AIR BRAKES, COMMONWEALTH BOGIES, E.T.H.3, TARE 33, DUAL HEATING (STEAM/ELECTRIC (BR)).
 1E COMMONWEALTH BOGIES, DUAL HEATING (STEAM/ELECTRIC (BR)), E.T.H.3, TARE 36.
 1G BR MK 1 LIGHT DOUBLE BOLSTER BOGIES, DUAL HEATING (STEAM/ELECTRIC (BR)), E.T.H.3, MAX. SPEED 90.
 2D AIR BRAKES, COMMONWEALTH BOGIES, E.T.H.3, TARE 33, ELECTRIC (BR/UIC) HEATING, MAX. SPEED 90.
 3F AIR BRAKES, BR MK 1 LIGHT DOUBLE BOLSTER BOGIES, E.T.H.3, TARE 33, DUAL HEATING (STEAM/ELECTRIC (BR)), MAX. SPEED 90.
 4E COMMONWEALTH BOGIES, DUAL HEATING (STEAM/ELECTRIC (BR)), E.T.H.3, TARE 36, FLUORESCENT & TUNGSTEN LIGHTING.

SECOND OPEN-MK 1

CLASS ---

TSO

AC 201

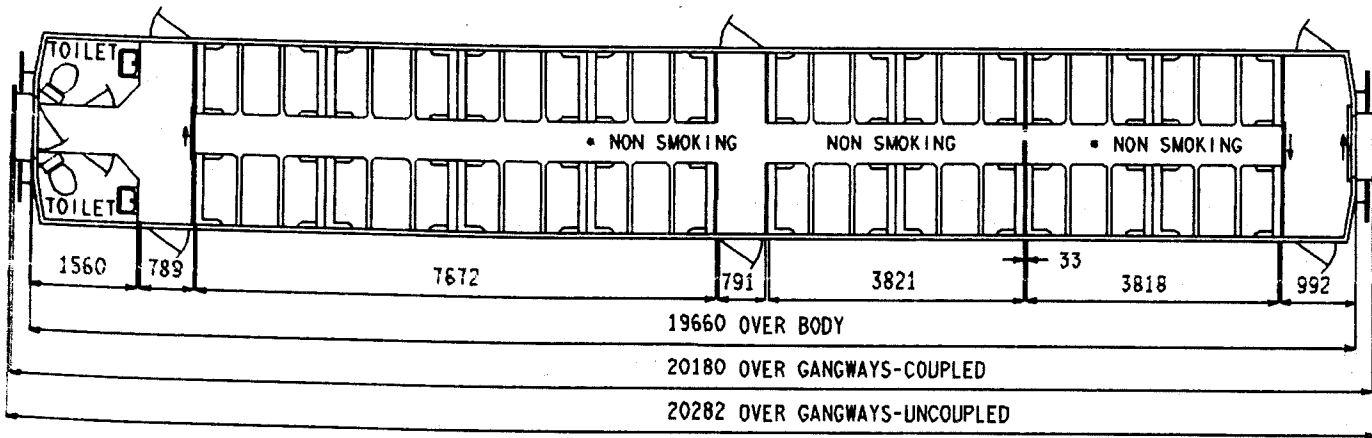
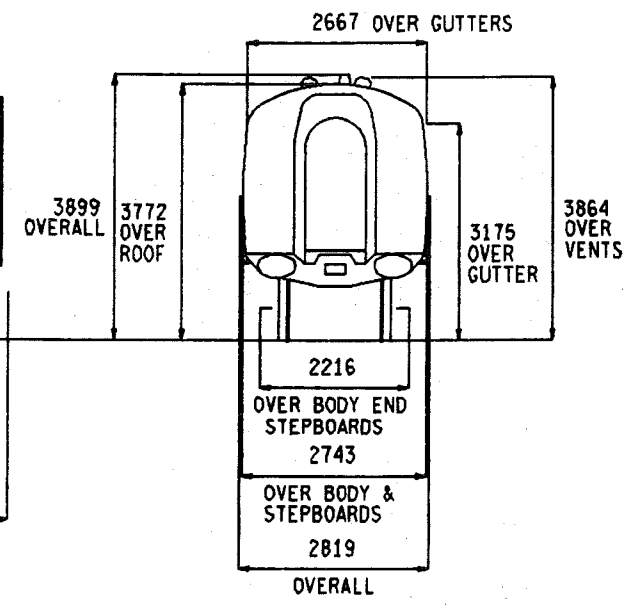
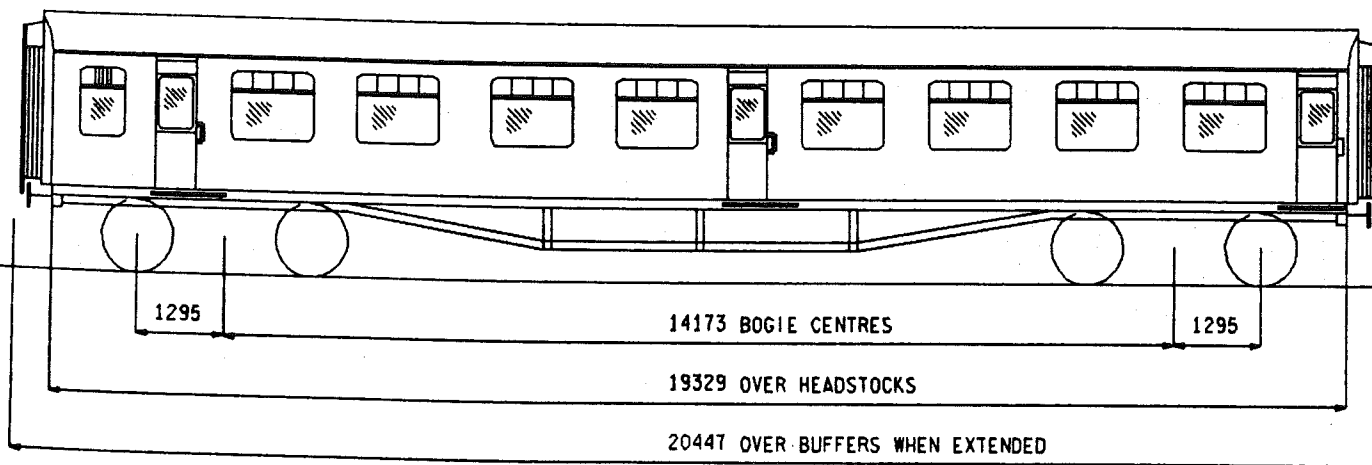

• THESE AREAS NON SMOKING ON SOME VEHICLES

SEATS	64
TOILETS	2
COMPARTMENTS	-
GUARDS COMPARTMENTS	-
VENTILATION	-
CATERING EQUIPMENT	-

ORIGINAL DIAGRAMS FOR REFERENCE - BR 89

ISSUE 8 DATE DEC 88

AC 201

	<u>BASIC TYPE</u>	<u>ALTERNATIVES</u>
BRAKES	VACUUM	VACUUM & AIR, AIR
BOGIE/SUSPENSION	COMMONWEALTH	B4, BR MK 1 LIGHT DOUBLE BOLSTER
BODY CONSTRUCTION	STEEL	
COUPLINGS	AUTOMATIC DROPHEAD (BUCKEYE)	
TRAIN HEATING	DUAL (STEAM/ELECTRIC (BR))	
E.T.H. INDEX	4	
MAX. SPEED M.P.H.	100	90
MIN. RAD. CURVE CHAINS	3.5	
LIGHTING	FLUORESCENT & TUNGSTEN	30.5, 31, 32.5
TARE WEIGHT TONNES	33.5	
GANGWAYS	PULLMAN	FITTED
TRAIN COMMUNICATION	NOT FITTED	
BUFFERS	RETRACTABLE SPINDLE (559X356 OVAL)	COMPOSITION
BRAKE BLOCKS	CAST IRON	62% NON SMOKING, 100% SMOKING
SMOKING ACCOMMODATION	50% NON SMOKING	

TRACTION DATA FOR MULTIPLE UNITSBASIC TYPE

AC 201 1A

VARIANTS

- 1B B4 BOGIES, TARE 30.5
- 1C BR MK 1 LIGHT DOUBLE BOLSTER BOGIES, MAX. SPEED 90, TARE 32.5
- 1E VACUUM & AIR BRAKES, 62% NON SMOKING, TARE 32.5
- 1F VACUUM & AIR BRAKES, B4 BOGIES, TARE 31.
- 1G B R MK 1 LIGHT DOUBLE BOLSTER BOGIES, MAX. SPEED 90, VACUUM & AIR BRAKES, COMPOSITION BRAKE BLOCKS, TARE 32.5
- 1J 62% NON SMOKING.
- 1K TARE 30.5, B4 BOGIES, 62% NON SMOKING.
- 1L BR MK 1 LIGHT DOUBLE BOLSTER BOGIES, MAX. SPEED 90, 62% NON SMOKING, TARE 32.5
- 1M VACUUM & AIR BRAKES, B4 BOGIES, TARE 31, 62.5% NON-SMOKING.
- 1N BR MK 1 LIGHT DOUBLE BOLSTER BOGIES, MAX. SPEED 90 VACUUM & AIR BRAKES, COMPOSITION BRAKE BLOCKS, 62% NON SMOKING, TARE 32.5
- 1P BR MK 1 LIGHT DOUBLE BOLSTER BOGIES, MAX. SPEED 90, 100% SMOKING, TARE 32.5
- 1Q BR MK 1 LIGHT DOUBLE BOLSTER BOGIES, MAX. SPEED 90, COMPOSITION BRAKE BLOCKS, TARE 32.5.
- 1R BR MK 1 LIGHT DOUBLE BOLSTER BOGIES MAX. SPEED 90, COMPOSITION BRAKE BLOCKS, 62% NON SMOKING, TARE 32.5
- 1S AIR BRAKES, ENHANCED INTERIOR
- 1T AIR BRAKES, ENHANCED INTERIOR, 62% NON SMOKING.
- 1U COMPOSITION BRAKE BLOCKS, 62% NON SMOKING.
- 1V COMPOSITION BRAKE BLOCKS.
- 2A P.A. FITTED
- 2B B4 BOGIES, TARE 30.5, P.A. FITTED
- 2L BR MK 1 LIGHT DOUBLE BOLSTER BOGIES, MAX. SPEED 90, 62% NON SMOKING, PUBLIC ADDRESS FITTED, TARE 32.5
- 4H FACELIFTED WITH INCREASE IN NO SMOKING ACCOMMODATION, TARE 32.5.
- 3H FACELIFTED WITH INCREASE IN NO SMOKING ACCOMMODATION, TARE 32.5, P.A. FITTED.

SECOND OPEN-MK I

CLASS ---

TSO

AC 201

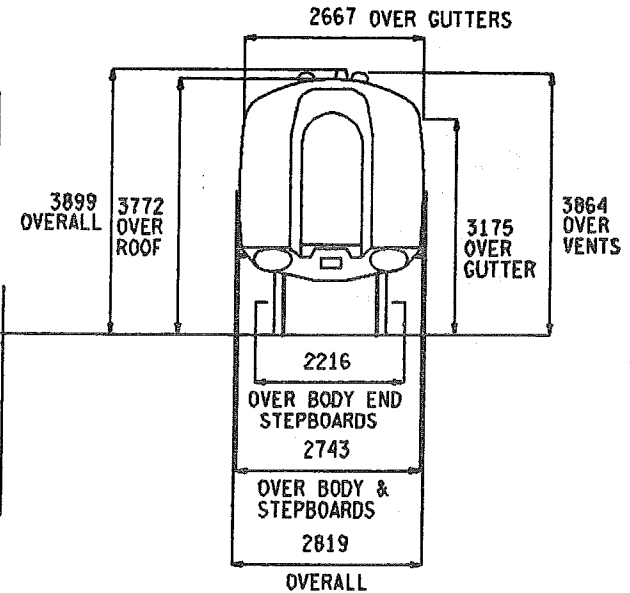
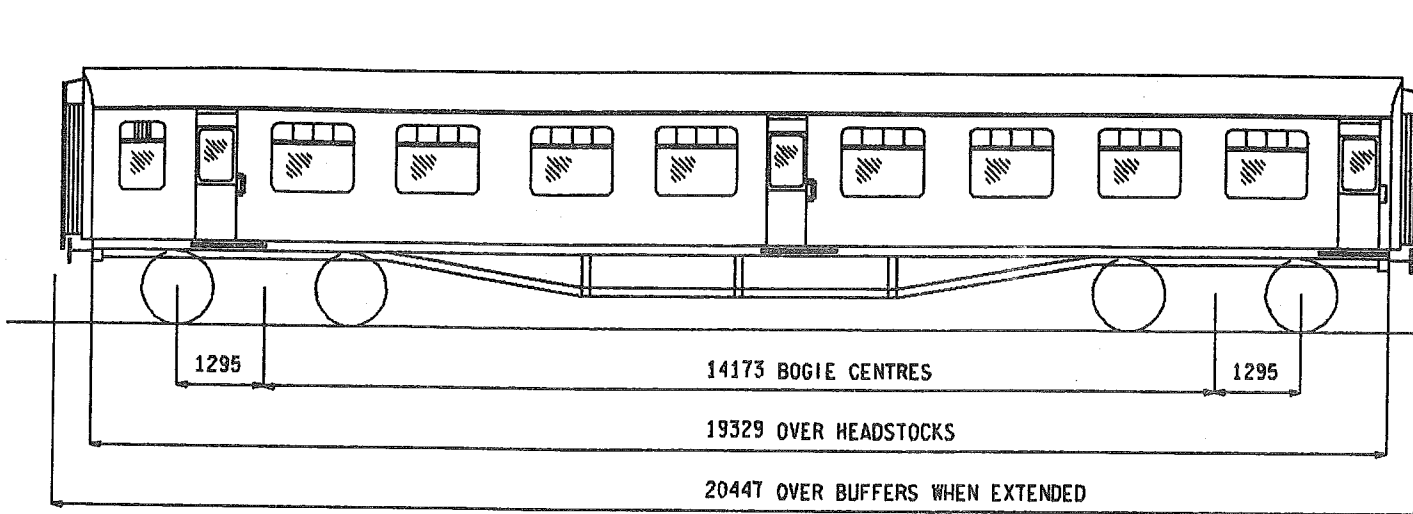

* THESE AREAS NON SMOKING ON SOME VEHICLES

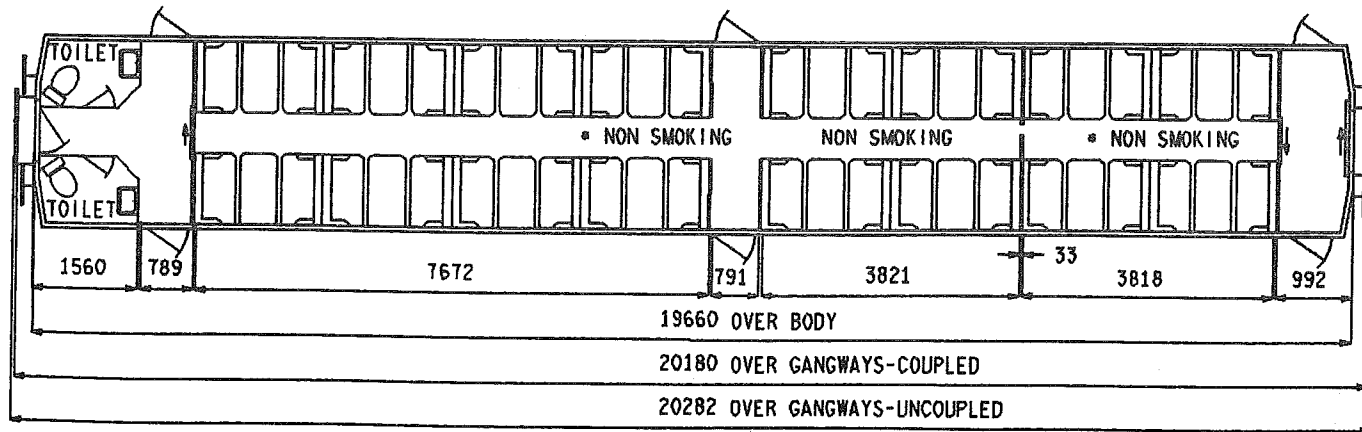

SEATS	64
TOILETS	2
COMPARTMENTS	-
GUARDS COMPARTMENTS	-
VENTILATION	-
CATERING EQUIPMENT	-

ORIGINAL DIAGRAMS FOR REFERENCE:-
BR 89

ISSUE 7
DATE DEC 88

AC 201

	<u>BASIC TYPE</u>	<u>ALTERNATIVES</u>
BRAKES	VACUUM	VACUUM & AIR, AIR
BOGIE/SUSPENSION	COMMONWEALTH	B4, BR MK 1 LIGHT DOUBLE BOLSTER
BODY CONSTRUCTION	STEEL	
COUPLINGS	AUTOMATIC DROPHEAD (BUCKEYE)	
TRAIN HEATING	DUAL (STEAM/ELECTRIC (BR))	
E.T.H. INDEX	4	90
MAX.SPEED M.P.H.	100	
MIN.RAD.CURVE CHAINS	3.5	30.5, 31, 32.5
LIGHTING	FLUORESCENT & TUNGSTEN	FITTED
TARE WEIGHT TONNES	33.5	
GANGWAYS	PULLMAN	
TRAIN COMMUNICATION	NOT FITTED	
BUFFERS	RETRACTABLE SPINDLE (559X356 OVAL)	
BRAKE BLOCKS	CAST IRON	COMPOSITION
SMOKING ACCOMMODATION	25% NON SMOKING	62% NON SMOKING, 100% SMOKING

TRACTION DATA FOR MULTIPLE UNITSBASIC TYPE

AC 201 1A

VARIANTS

- 1B B4 BOGIES, TARE 30.5
- 1C BR MK 1 LIGHT DOUBLE BOLSTER BOGIES, MAX.SPEED 90, TARE 32.5
- 1E VACUUM & AIR BRAKES, 62% NON SMOKING, TARE 32.5
- 1F VACUUM & AIR BRAKES, B4 BOGIES, TARE 31.
- 1G B R MK 1 LIGHT DOUBLE BOLSTER BOGIES, MAX.SPEED 90, VACUUM & AIR BRAKES, COMPOSITION BRAKE BLOCKS, TARE 32.5
- 1J 62% NON SMOKING.
- 1K TARE 30.5, B4 BOGIES, 62% NON SMOKING.
- 1L BR MK 1 LIGHT DOUBLE BOLSTER BOGIES, MAX.SPEED 90, 62% NON SMOKING, TARE 32.5
- 1M VACUUM & AIR BRAKES, B4 BOGIES, TARE 31, 62.5% NON-SMOKING.
- 1N BR MK 1 LIGHT DOUBLE BOLSTER BOGIES, MAX.SPEED 90 VACUUM & AIR BRAKES, COMPOSITION BRAKE BLOCKS, 62% NON SMOKING, TARE 32.5
- 1P BR MK 1 LIGHT DOUBLE BOLSTER BOGIES, MAX.SPEED 90, 100% SMOKING, TARE 32.5
- 1Q BR MK 1 LIGHT DOUBLE BOLSTER BOGIES, MAX.SPEED 90, COMPOSITION BRAKE BLOCKS, TARE 32.5.
- 1R BR MK 1 LIGHT DOUBLE BOLSTER BOGIES, MAX.SPEED 90, COMPOSITION BRAKE BLOCKS, 62% NON SMOKING, TARE 32.5
- 1S AIR BRAKES, ENHANCED INTERIOR
- 1T AIR BRAKES, ENHANCED INTERIOR, 62% NON SMOKING.
- 2L BR MK 1 LIGHT DOUBLE BOLSTER BOGIES, MAX.SPEED 90, 62% NON SMOKING, PUBLIC ADDRESS FITTED, TARE 32.5
- 3H FACELIFTED WITH INCREASE IN NO SMOKING ACCOMMODATION, TARE 32.5.

SECOND OPEN-MK I

CLASS ---

TSO

AC 204

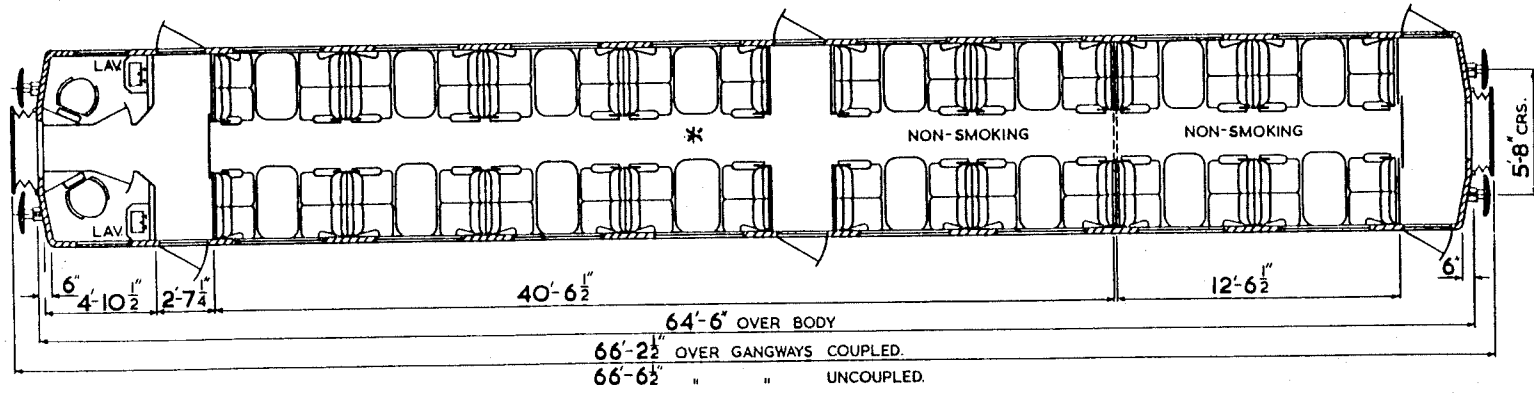
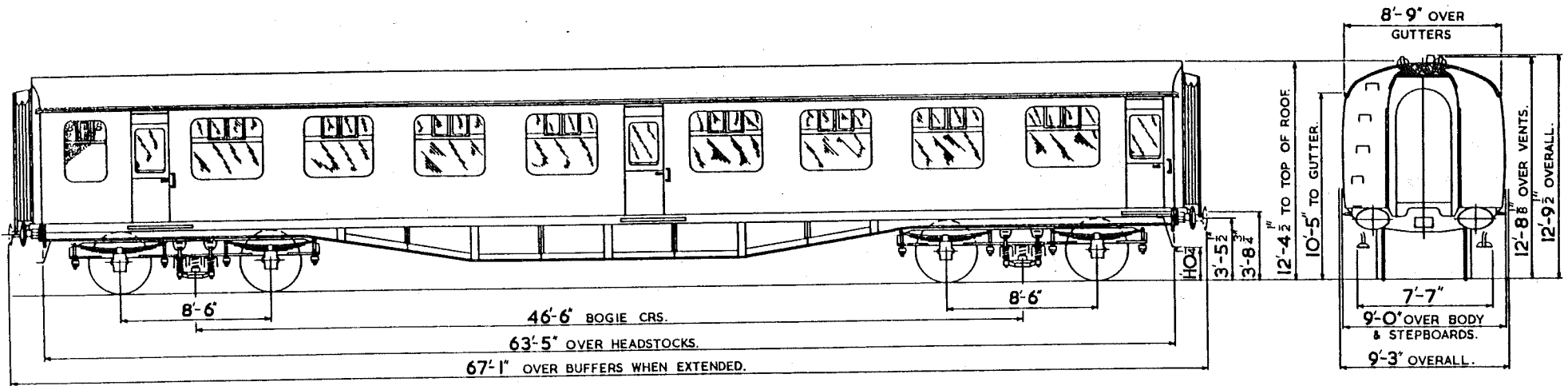

N.S. - NON SMOKING

* THIS BAY N.S. ON SOME VEHICLES.SEE VARIANTS

SEATS	64
TOILETS	2
COMPARTMENTS	-
GUARDS COMPARTMENTS	-
VENTILATION	-
CATERING EQUIPMENT	-

ORIGINAL DIAGRAMS FOR REFERENCE:-
BR 93

ISSUE 4 DATE OCT '86

AC 204

BRAKES
BOGIE/SUSPENSION
BODY CONSTRUCTION
COUPLINGS
TRAIN HEATING

E.T.H. INDEX
MAX. SPEED M.P.H.
MIN. RAD. CURVE CHAINS
LIGHTING
TARE WEIGHT TONNES
GANGWAYS
TRAIN COMMUNICATION
BUFFERS
BRAKE BLOCKS
SMOKING ACCOMMODATION

BASIC TYPE

VACUUM
B4
STEEL
AUTOMATIC DROPHEAD (BUCKEYE)
STEAM

-
100
3.5
TUNGSTEN
33.5
PULLMAN
NOT FITTED
RETRACTABLE SPINDLE (559X356 OVAL)
CAST IRON
50% NON SMOKING

ALTERNATIVES

AIR
BR MK 1 LIGHT DOUBLE BOLSTER, COMMONWEALTH

DUAL (STEAM/ELECTRIC (BR)), ELECTRIC (BR),
ELECTRIC (BR/UIC)
4, 4 WITH 675 VOLT HEATERS
90

FLUORESCENT & TUNGSTEN

COMPOSITION
62.5% NON SMOKING

TRACTION DATA FOR MULTIPLE UNITSBASIC TYPE

AC 204 OA

VARIANTS

0B BR MK 1 LIGHT DOUBLE BOLSTER BOGIES, MAX. SPEED 90.
1B BR MK 1 LIGHT DOUBLE BOLSTER BOGIES, MAX. SPEED 90, DUAL HEATING (STEAM/ELECTRIC (BR)), E.T.H. 4.
1E BR MK 1 LIGHT DOUBLE BOLSTER BOGIES, MAX. SPEED 90, DUAL HEATING (STEAM/ELECTRIC (BR)), E.T.H. 4, COMPOSITION BRAKE BLOCKS.
3C COMMONWEALTH BOGIES, ELECTRIC (BR) HEATING, AIR BRAKES, E.T.H. 4 WITH 675 VOLT HEATERS, MAX. SPEED 90.
3D BR MK 1 LIGHT DOUBLE BOLSTER BOGIES, MAX. SPEED 90, ELECTRIC (BR) HEATING, E.T.H. 4 WITH 675 VOLT HEATERS, AIR BRAKES.
4D BR MK 1 LIGHT DOUBLE BOLSTER BOGIES, MAX. SPEED 90, ELECTRIC (BR/UIC) HEATING, E.T.H. 4 WITH 675 VOLT HEATERS, AIR BRAKES.
5B BR MK 1 LIGHT DOUBLE BOLSTER BOGIES, MAX. SPEED 90, FLUORESCENT & TUNGSTEN LIGHTING.
0F BR MK 1 LIGHT DOUBLE BOLSTER BOGIES, MAX. SPEED 90, 62.5% NON SMOKING.
1F BR MK 1 LIGHT DOUBLE BOLSTER BOGIES, MAX. SPEED 90, DUAL HEATING (STEAM/ELECTRIC (BR)), E.T.H. 4, 62.5% NON SMOKING.

STANDARD OPEN-MK 11

CLASS ---

TSO

AC 205

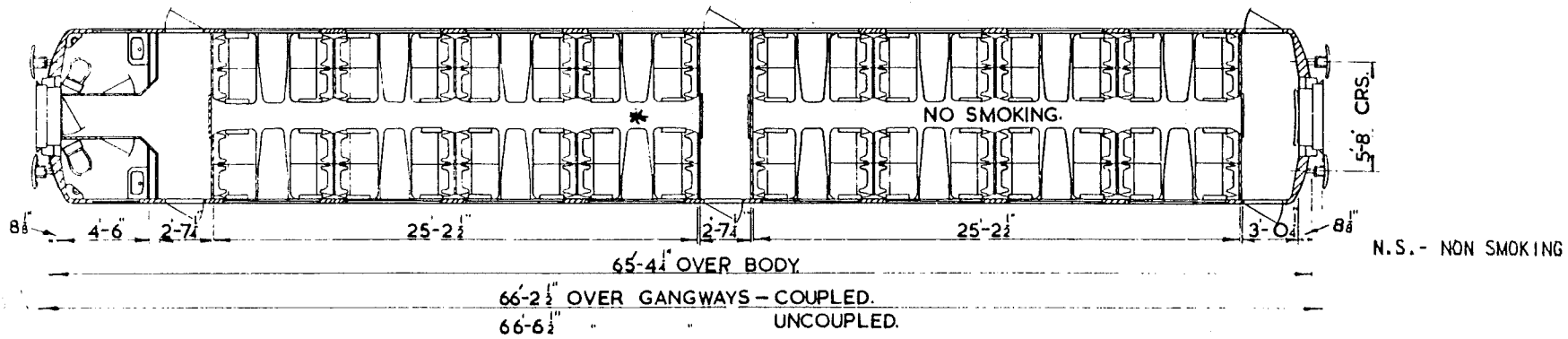
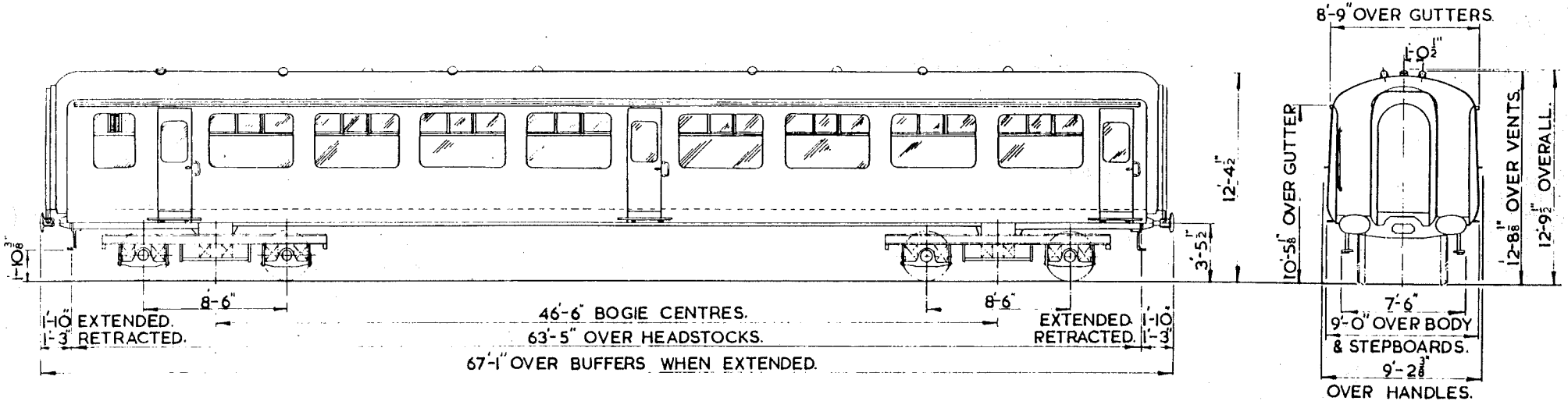

* THIS BAY N.S.ON
SOME VEHICLES.SEE VARIANTS

SOME VEHICLES ALL NON SMOKING

SEATS	64
TOILETS	2
COMPARTMENTS	-
GUARDS COMPARTMENTS	-
VENTILATION	PRESSURE
CATERING EQUIPMENT	-

ORIGINAL DIAGRAMS FOR REFERENCE:-
BR 88

ISSUE 5 DATE APR 88

AC 205

BRAKES
 BOGIE/SUSPENSION
 BODY CONSTRUCTION
 COUPLINGS
 TRAIN HEATING
 E.T.H. INDEX
 MAX.SPEED M.P.H.
 MIN.RAD.CURVE CHAINS
 LIGHTING
 TARE WEIGHT TONNES
 GANGWAYS
 TRAIN COMMUNICATION
 BUFFERS
 BRAKE BLOCKS
 BUFFERS

BASIC TYPE

VACUUM
 B4
 STEEL
 AUTOMATIC DROPHEAD(BUCKEYE)
 DUAL(STEAM/ELECTRIC(BR))WITH PRESSURE VENTILATION & HEATING
 4
 100
 3.5
 FLUORESCENT & TUNGSTEN
 32.5
 PULLMAN
 NOT FITTED
 RETRACTABLE SPINDLE(559X356 OVAL)
 CAST IRON
 50% NON SMOKING

ALTERNATIVES

AIR

FITTED

COMPOSITION
 62.5% NON SMOKING

TRACTION DATA FOR MULTIPLE UNITSBASIC TYPE

AC 205 0A

VARIANTS

0B AIR BRAKES.
 0C COMPOSITION BRAKE BLOCKS.
 0D ALL VEHICLE NON SMOKING.
 0E AIR BRAKES,62.5% NON SMOKING
 1A PUBLIC ADDRESS.
 1B PUBLIC ADDRESS,AIR BRAKES.

STANDARD OPEN-MK 11A

CLASS ---

TSO

AC 206

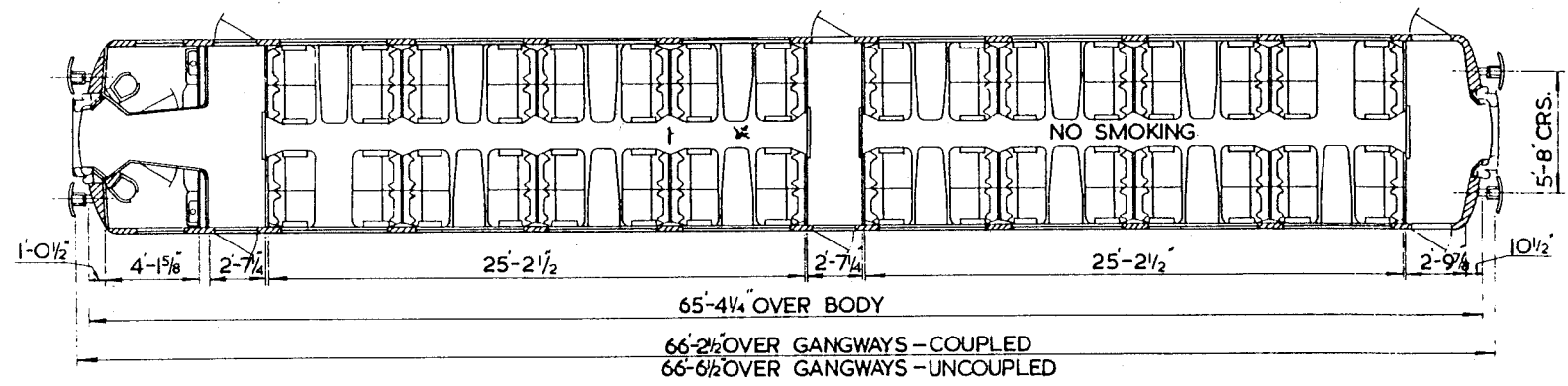
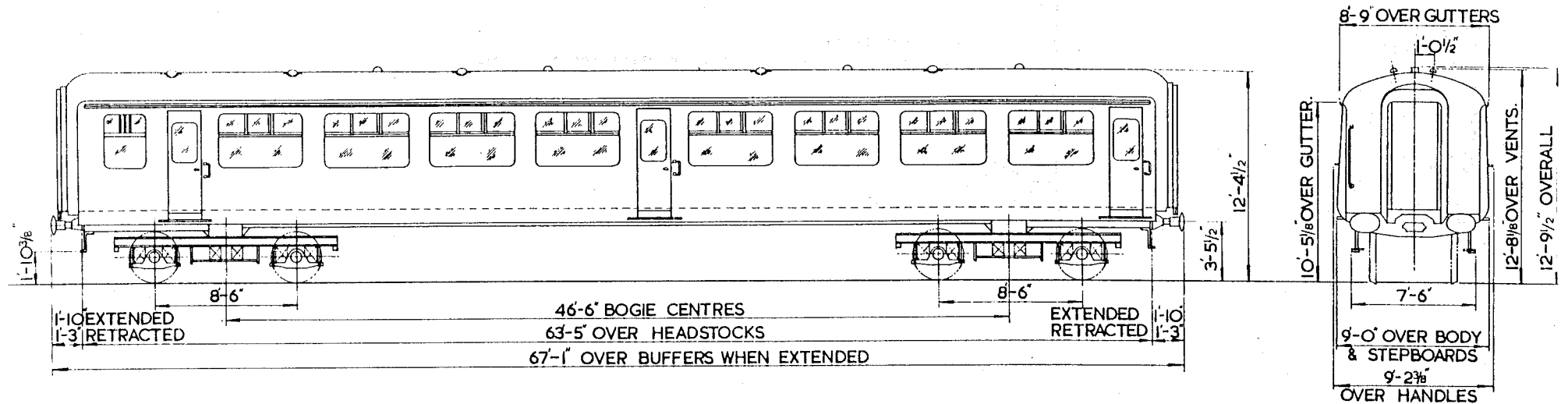

NO SMOKING

N.S. - NON SMOKING

* THIS BAY N.S. ON SOME VEHICLES. SEE VARIANTS

SEATS	64
TOILETS	2
COMPARTMENTS	-
GUARDS COMPARTMENTS	-
VENTILATION	PRESSURE
CATERING EQUIPMENT	-

ORIGINAL DIAGRAMS FOR REFERENCE:-
BR 86

ISSUE 3 DATE APR 88

AC 206

BRAKES
 BOGIE/SUSPENSION
 BODY CONSTRUCTION
 COUPLINGS
 TRAIN HEATING
 E.T.H. INDEX
 MAX.SPEED M.P.H.
 MIN.RAD.CURVE CHAINS
 LIGHTING
 TARE WEIGHT TONNES
 GANGWAYS
 TRAIN COMMUNICATION
 BUFFERS
 SMOKING ACCOMMODATION

BASIC TYPE

AIR
 B4
 STEEL
 AUTOMATIC DROPHEAD(BUCKEYE)
 DUAL(STEAM/ELECTRIC(BR))WITH PRESSURE VENTILATION & HEATING.
 4
 100
 3.5
 FLUORESCENT & TUNGSTEN
 32.5
 PULLMAN
 NOT FITTED
 RETRACTABLE SPINDLE(559X356 OVAL)
 50% NON SMOKING

ALTERNATIVES

BR MK 1 LIGHT DOUBLE BOLSTER

34

FITTED

62.5% NON SMOKING

TRACTION DATA FOR MULTIPLE UNITSBASIC TYPE

AC 206 0A

VARIANTS

OB TARE 34, BR MK 1 LIGHT DOUBLE BOLSTER BOGIES.
 OC 62.5% NON SMOKING
 OD TARE 34, BR MK 1 LIGHT DOUBLE BOLSTER BOGIES, 62.5% NON SMOKING.
 1A PUBLIC ADDRESS.
 1C PUBLIC ADDRESS, 62.5% NON SMOKING
 1B PUBLIC ADDRESS, TARE 34, BR MK 1 LIGHT DOUBLE BOLSTER BOGIES.

SECOND OPEN-MK 11B

CLASS ---

TSO

AC 207

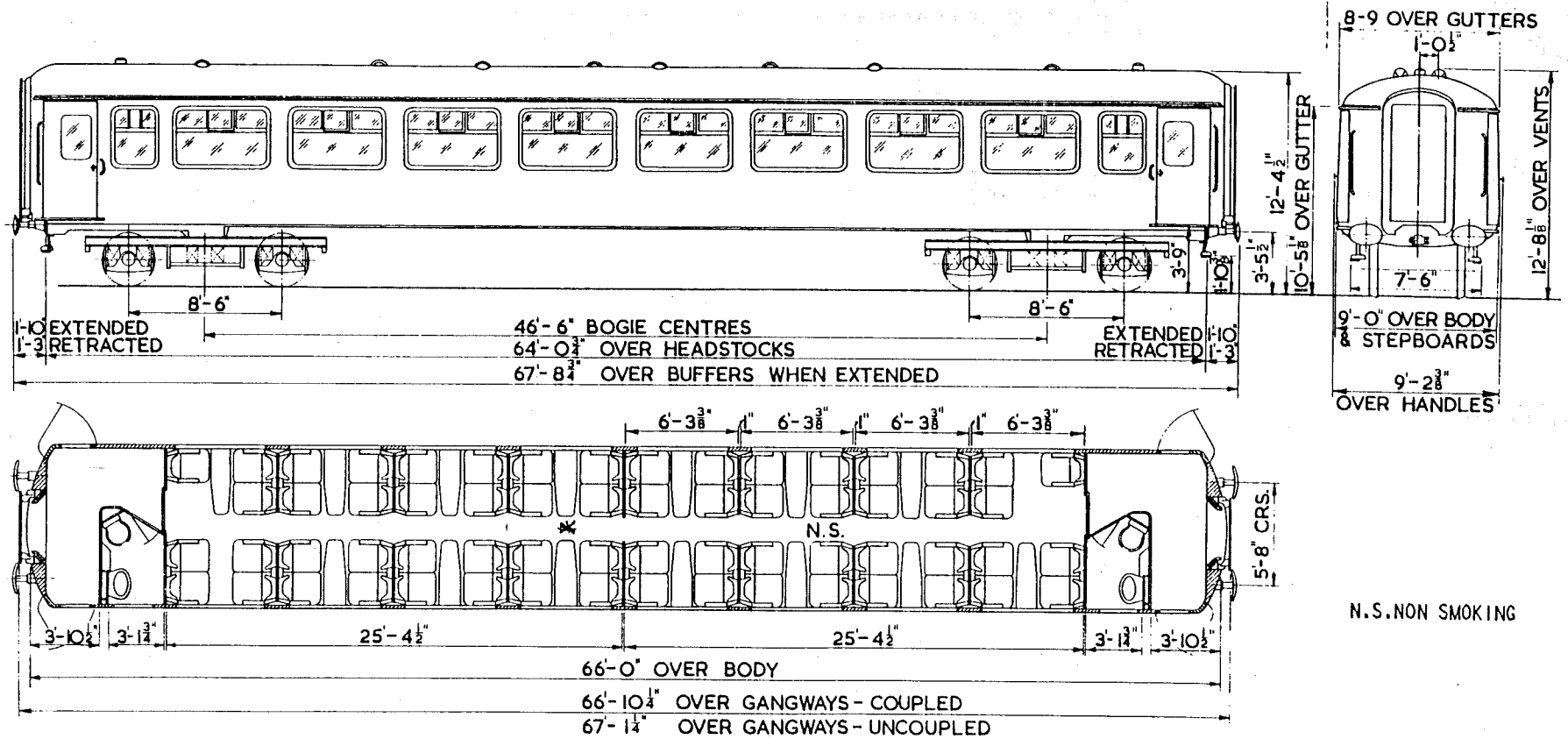

* THIS BAY N.S. ON SOME VEHICLES. SEE VARIANTS

SEATS	62
TOILETS	2
COMPARTMENTS	-
GUARDS COMPARTMENTS	-
VENTILATION	PRESSURE
CATERING EQUIPMENT	-

ORIGINAL DIAGRAMS FOR REFERENCE:- BR 105

ISSUE 2 DATE OCT '86

AC 207

BRAKES
 BOGIE/SUSPENSION
 BODY CONSTRUCTION
 COUPLINGS
 TRAIN HEATING
 E.T.H. INDEX
 MAX.SPEED M.P.H.
 MIN.RAD.CURVE CHAINS
 LIGHTING
 TARE WEIGHT TONNES
 GANGWAYS
 TRAIN COMMUNICATION
 BUFFERS
 SMOKING ACCOMMADATION

BASIC TYPE

AIR
 B4
 STEEL
 AUTOMATIC DROPHEAD(BUCKEYE)
 DUAL(STEAM/ELECTRIC(BR))WITH PRESSURE VENTILATION & HEATING
 4
 100
 3.5
 FLUORESCENT & TUNGSTEN
 32.5
 PULLMAN
 NOT FITTED
 RETRACTABLE SPINDLE(559X356 OVAL)
 50% NON SMOKING

ALTERNATIVES

62.5% NON SMOKING

TRACTION DATA FOR MULTIPLE UNITS

BASIC TYPE

AC 207 OA

VARIANTS

OB 62.5% NON SMOKING

SECOND OPEN-MK 11C

CLASS ---

TSO

AC 208

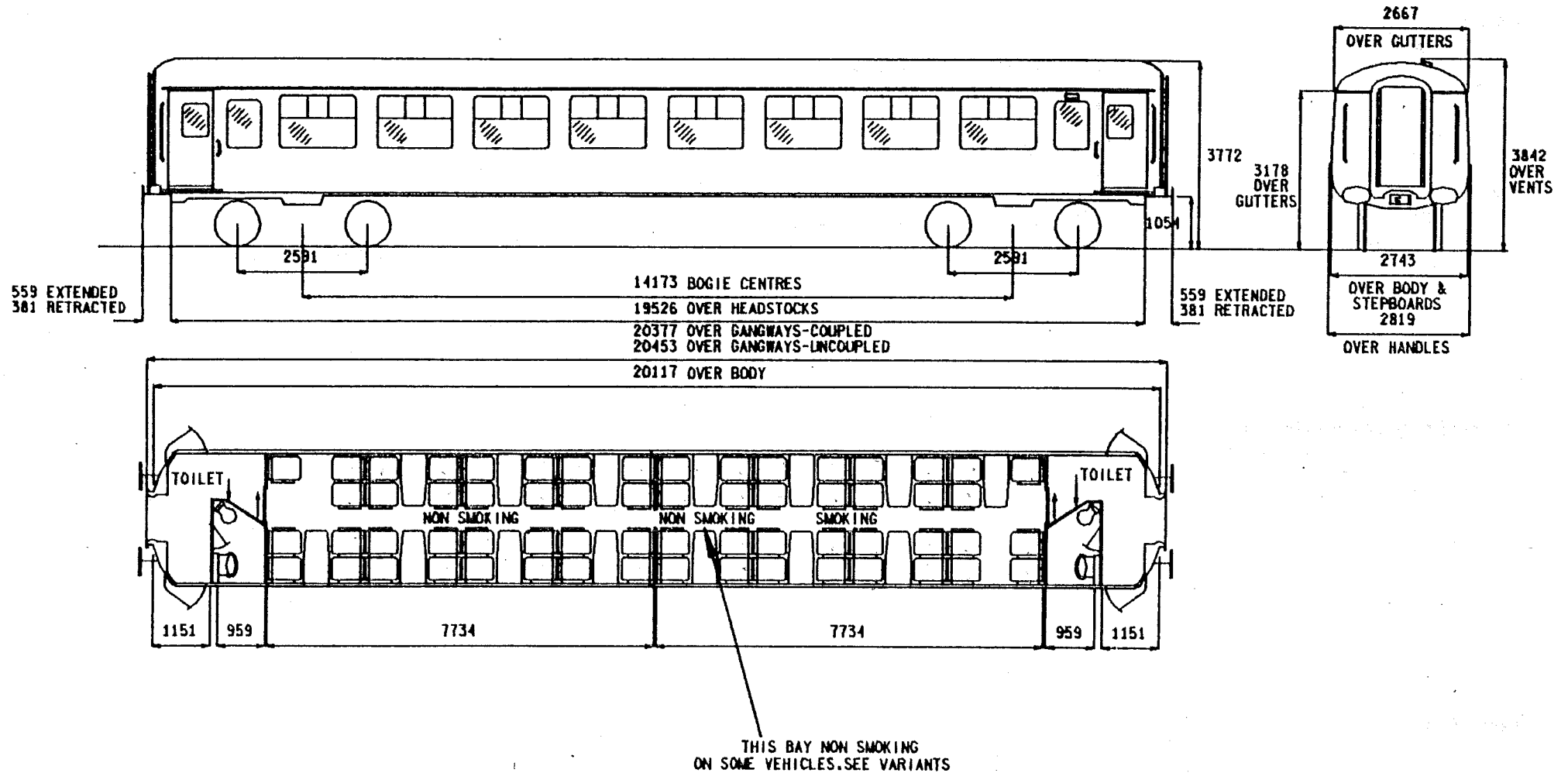

ORIGINAL DIAGRAMS FOR REFERENCE.

BR 106

ISSUE	DATE
2	OCT 86

AC 208

BRAKES
BOGIE/SUSPENSION
BODY CONSTRUCTION
COUPLINGS
TRAIN HEATING
E.T.H. INDEX
MAX.SPEED M.P.H.
MIN.RAD.CURVE CHAINS
LIGHTING
TARE WEIGHT TONNES
GANGWAYS
TRAIN COMMUNICATION
BUFFERS
SMOKING ACCOMMODATION

BASIC TYPE

AIR
B4
STEEL
AUTOMATIC DROPHEAD(BUCKEYE)
DUAL(STEAM/ELECTRIC(BR))WITH PRESSURE VENTILATION & HEATING
4
100
3.5
FLUORESCENT & TUNGSTEN
32
PULLMAN
NOT FITTED
RETRACTABLE SPINDLE(559X356 OVAL)
50% NON SMOKING

ALTERNATIVES

PUBLIC ADDRESS
62.5% NON SMOKING

TRACTION DATA FOR MULTIPLE UNITS

BASIC TYPE

AC 208 OA

VARIANTS

OB 62.5% NON SMOKING
1A PUBLIC ADDRESS
1B PUBLIC ADDRESS,62.5% NON SMOKING

SECOND OPEN-MK IID

CLASS ---

TSO

AC 209

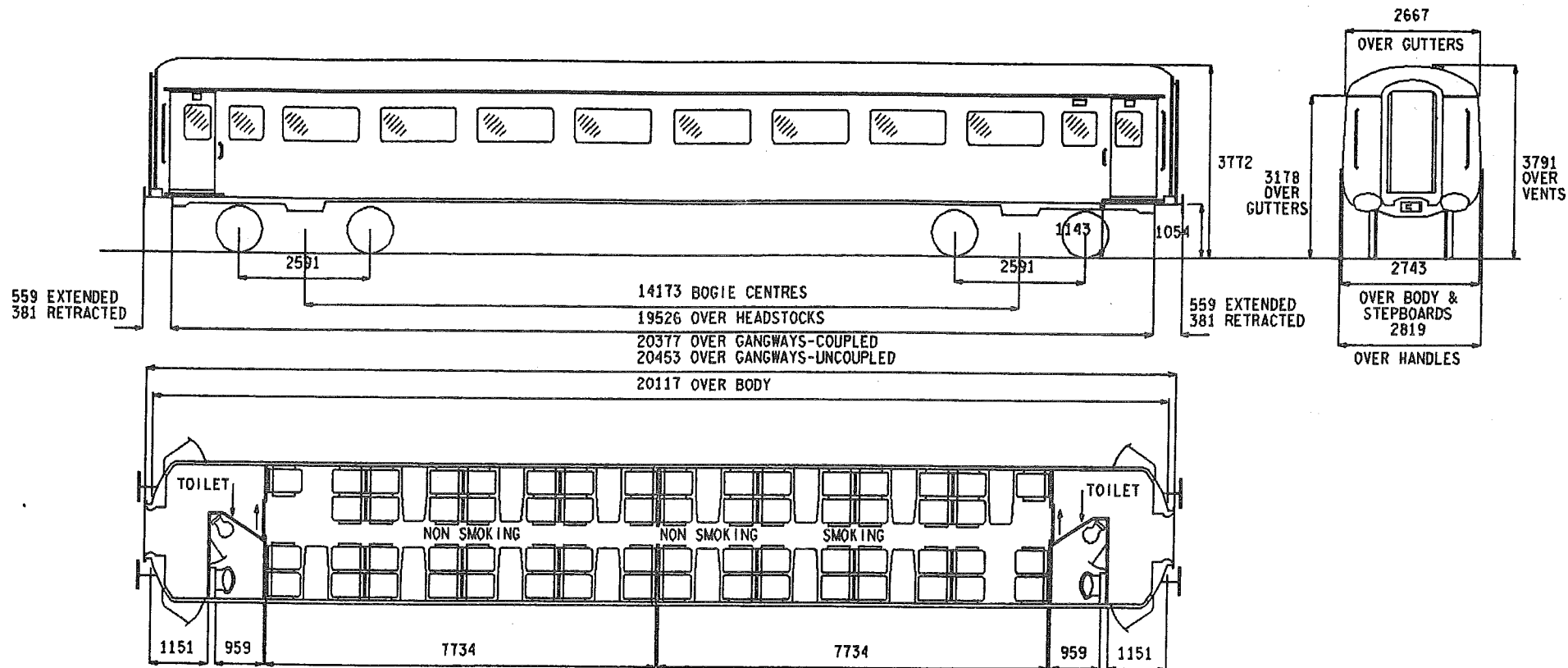

FOR NON SMOKING IN THIS BAY SEE VARIANTS

SEATS	62
TOILETS	2
COMPARTMENTS	-
GUARDS COMPARTMENTS	-
VENTILATION	FULL AIR CONDITIONING
CATERING EQUIPMENT	-

ORIGINAL DIAGRAMS FOR REFERENCE:-
BR 107

ISSUE 3 DATE DEC 88

AC 209

BASIC TYPE

ALTERNATIVES

BRAKES
BOGIE/SUSPENSION
BODY CONSTRUCTION
COUPLINGS
TRAIN HEATING
E.T.H. INDEX
MAX. SPEED M.P.H.
MIN. RAD. CURVE CHAINS
LIGHTING
TARE WEIGHT TONNES
GANGWAYS
TRAIN COMMUNICATION
BUFFERS
SMOKING ACCOMMODATION

AIR
B4
STEEL
AUTOMATIC DROPHEAD(BUCKEYE)
ELECTRIC(BR)FULL AIR CONDITIONING NOT SUITED TO CLASS 55 LOCOS
5
100
3.5
FLUORESCENT & TUNGSTEN
34
PULLMAN
PUBLIC ADDRESS
RETRACTABLE SPINDLE(559X356 OVAL)
50% NON SMOKING

62.5% NON SMOKING

TRACTION DATA FOR MULTIPLE UNITS

BASIC TYPE

AC 209 DA

VARIANTS

OB 62.5% NON SMOKING
OC 100% NON SMOKING
OD 100% SMOKING

SECOND OPEN-MK 11E

CLASS ---

TSO

AC 210

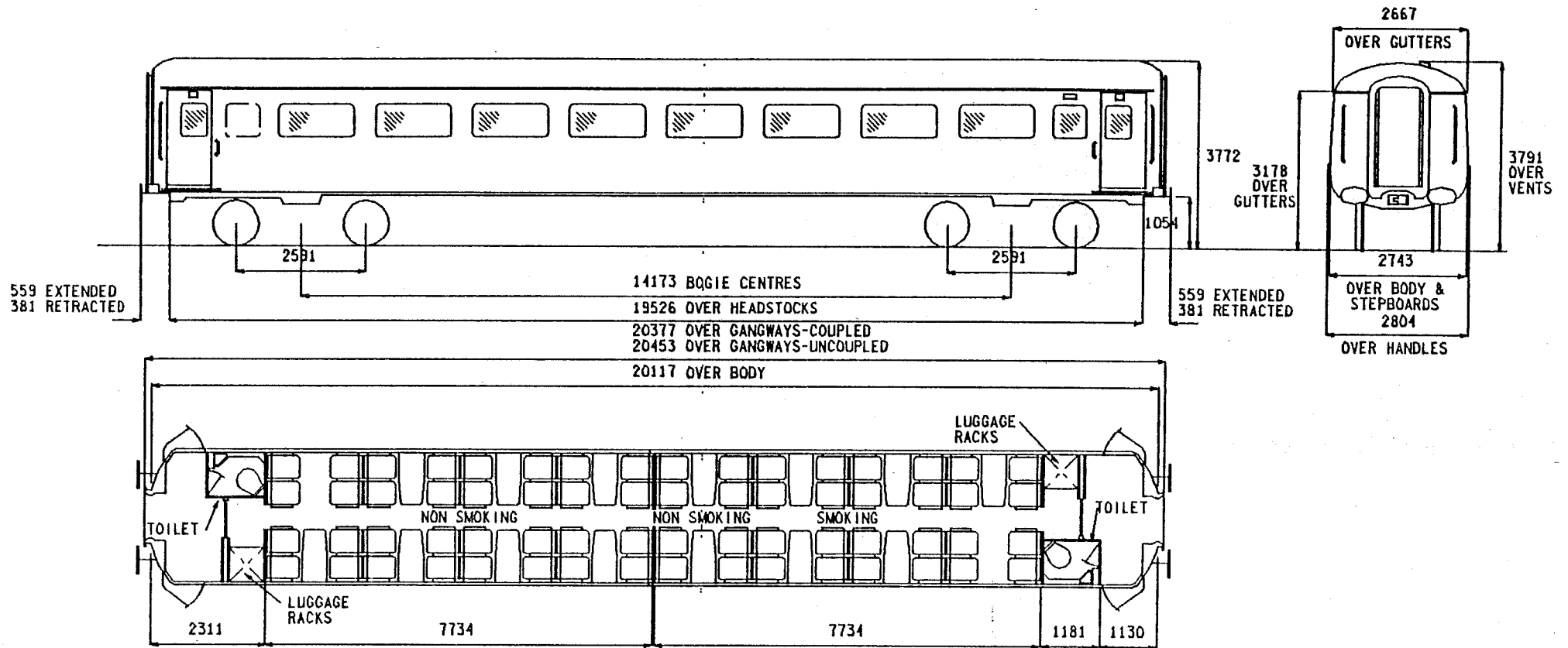

SEATS	64
TOILETS	2
COMPARTMENTS	-
GUARDS COMPARTMENTS	-
VENTILATION	FULL AIR CONDITIONING
CATERING EQUIPMENT	-

ORIGINAL DIAGRAMS FOR REFERENCE:-
BR 108

ISSUE 2 DATE DEC 86

AC 210

BASIC TYPE

ALTERNATIVES

BRAKES
BOGIE/SUSPENSION
BODY CONSTRUCTION
COUPLINGS
TRAIN HEATING
E.T.H. INDEX
MAX.SPEED M.P.H.
MIN.RAD.CURVE CHAINS
LIGHTING
TARE WEIGHT TONNES
GANGWAYS
TRAIN COMMUNICATION
BUFFERS

AIR
B4
STEEL
AUTOMATIC DROPHEAD(BUCKEYE)
ELECTRIC(BR)FULL AIR CONDITIONING NOT SUITED TO CLASS 55 LOCOS
5
100
3.5
FLUORESCENT & TUNGSTEN
34
PULLMAN
PUBLIC ADDRESS
RETRACTABLE SPINDLE(559X356 OVAL)

TRACTION DATA FOR MULTIPLE UNITS

BASIC TYPE

AC 210 OA

VARIANTS

OB 100% NON SMOKING

SECOND OPEN-MK 11F

CLASS ---

TSO

AC 211

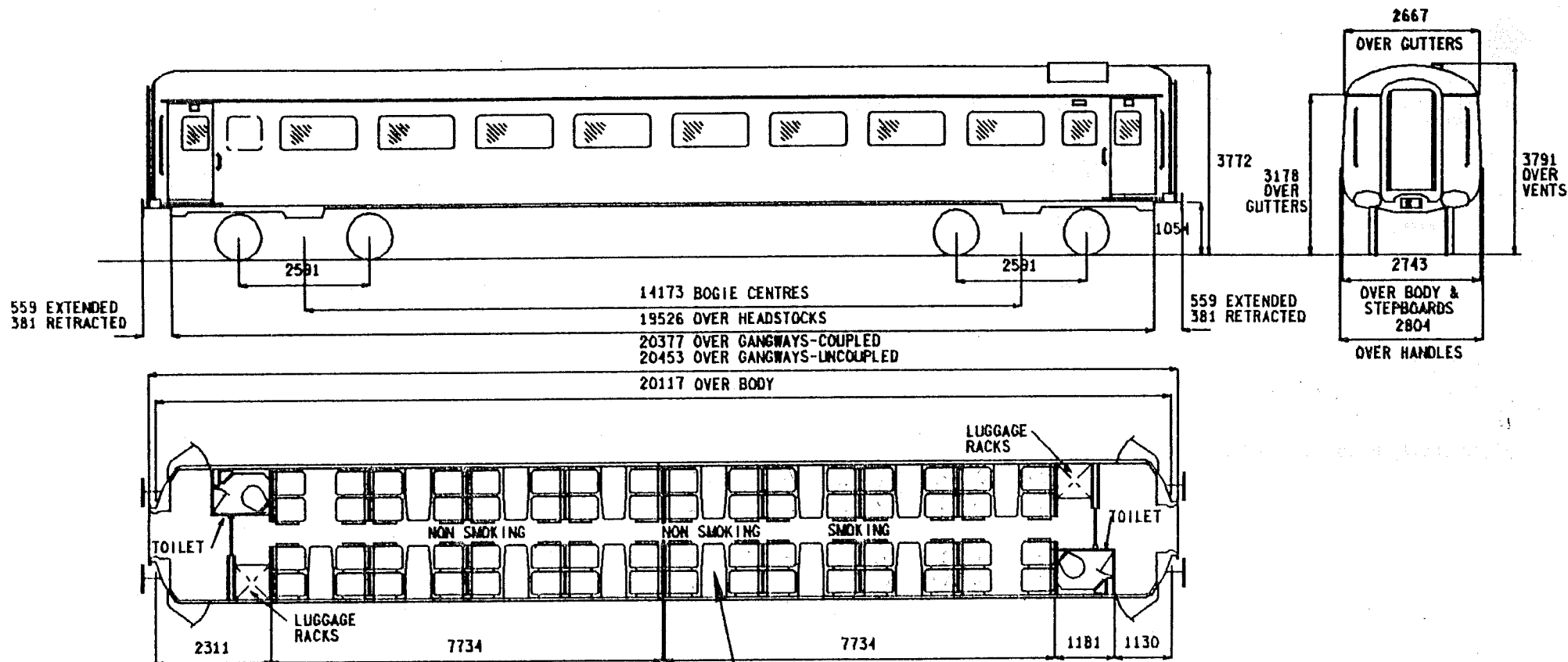

THIS BAY NON SMOKING ON SOME VEHICLES.SEE VARIANTS

SEATS	64
TOILETS	2
COMPARTMENTS	-
GUARDS COMPARTMENTS	-
VENTILATION	FULL AIR CONDITIONING
CATERING EQUIPMENT	-

ORIGINAL DIAGRAMS FOR REFERENCE:- BR 109

ISSUE 6 DATE OCT 86

AC 211

BRAKES
 BOGIE/SUSPENSION
 BODY CONSTRUCTION
 COUPLINGS
 TRAIN HEATING
 E.T.H. INDEX
 MAX.SPEED M.P.H.
 MIN.RAD.CURVE CHAINS
 LIGHTING
 TARE WEIGHT TONNES
 GANGWAYS
 TRAIN COMMUNICATION
 BUFFERS
 SEATS
 SMOKING ACCOMMODATION

BASIC TYPE

AIR
 B4
 STEEL
 AUTOMATIC DROPHEAD(BUCKEYE)
 ELECTRIC(BR)FULL AIR CONDITIONING
 5 PLUS 600 AMP WIRING
 100
 3.5
 FLUORESCENT & TUNGSTEN
 33.5
 PULLMAN
 PUBLIC ADDRESS
 RETRACTABLE SPINDLE(559X356 OVAL)
 STD. MK 11
 50% NON SMOKING

ALTERNATIVES

IC 70
 62.5% NON SMOKING

TRACTION DATA FOR MULTIPLE UNITS

BASIC TYPE

AC 211 DA

VARIANTS

OB IC 70 SEATS.
 OC 62.5% NON SMOKING.
 OD IC 70 SEATS, 62.5% NON SMOKING.

SECOND OPEN-MK 111A

CLASS ---

TSO

AC 212

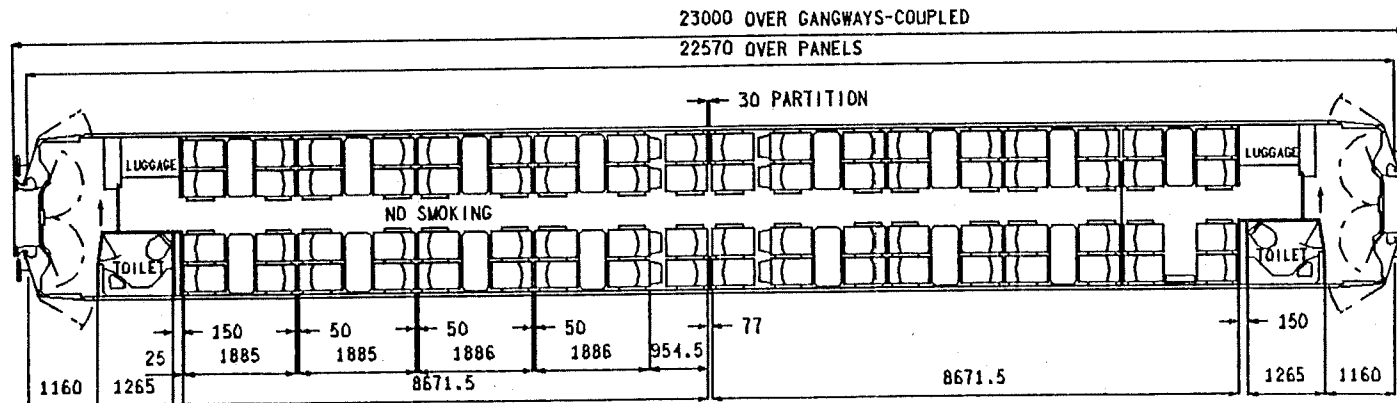
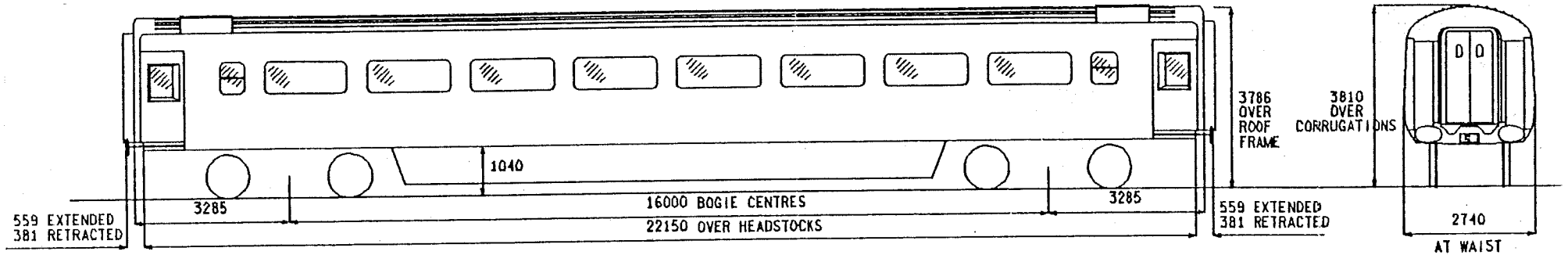

SOME VEHICLES ALL NON SMOKING

- SEATS 72
- TOILETS 2
- COMPARTMENTS -
- GUARDS COMPARTMENTS -
- VENTILATION -
- CATERING EQUIPMENT -
- FULL AIR CONDITIONING -

ORIGINAL DIAGRAMS FOR REFERENCE:-
BR 111

ISSUE 3 DATE APR 87

AC 212

BRAKES
BOGIE/SUSPENSION
BODY CONSTRUCTION
COUPLINGS
TRAIN HEATING
E.T.H. INDEX
MAX. SPEED M.P.H.
MIN. RAD. CURVE CHAINS
LIGHTING
TARE WEIGHT TONNES
GANGWAYS

TRAIN COMMUNICATION
BUFFERS

BASIC TYPE

AIR
BT10
STEEL
AUTOMATIC DROPHEAD (BUCKEYE)
ELECTRIC (BR) FULL AIR CONDITIONING
6 PLUS 500 AMP WIRING
125
4.5
FLUORESCENT & TUNGSTEN
33
CENTRALLY SUPPORTED-SWIVELLING-FOAM DIAPHRAGM-STEEL FACE PLATE
PUBLIC ADDRESS
RETRACTABLE SPINDLE (559X358 OVAL)

ALTERNATIVES

BT 15, BT 7

4.1

CENTRALLY SUPPORTED-SWIVELLING-FLEXIBLE DIAPHRAGM-STEEL FACE PLATE

TRACTION DATA FOR MULTIPLE UNITSBASIC TYPE

AC 212 DA

VARIANTS

0B GANGWAY HAS FLEXIBLE DIAPHRAGM, 100% NON SMOKING.
0D BT 15 BOGIES, MIN. RAD. CURVE 4.1.
0E 100% NON SMOKING.
0F BT 15 BOGIES, MIN. RAD. CURVE 4.1, 100% NON SMOKING.
1C BT 7 BOGIES, MIN. RAD. CURVE 4.1, 100% NON SMOKING.

SECOND OPEN-MK 111A

CLASS ---

TSO

AC 213

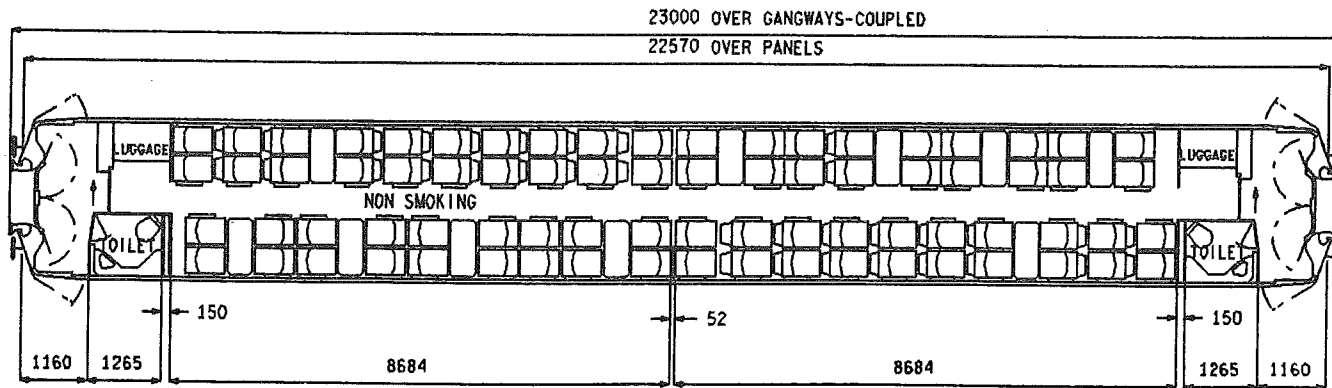
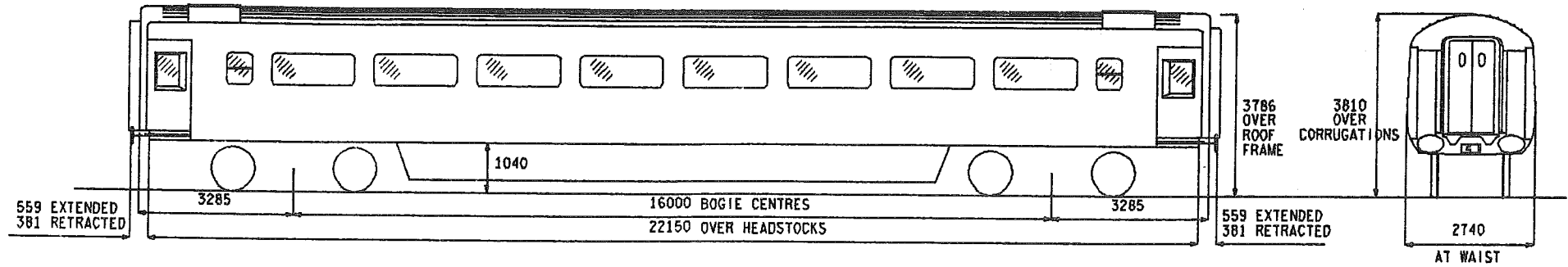

SOME VEHICLES ALL NON SMOKING

- SEATS 76
- TOILETS 2
- COMPARTMENTS -
- GUARDS COMPARTMENTS -
- VENTILATION FULL AIR CONDITIONING
- CATERING EQUIPMENT -

ISSUE 2 DATE OCT 88

AC 213

BASIC TYPE

ALTERNATIVES

BRAKES
BOGIE/SUSPENSION
BODY CONSTRUCTION
COUPLINGS
TRAIN HEATING
E.T.H. INDEX
MAX. SPEED M.P.H.
MIN. RAD. CURVE CHAINS
LIGHTING
TARE WEIGHT TONNES
GANGWAYS
TRAIN COMMUNICATION
BUFFERS

AIR
BT10
STEEL
AUTOMATIC DROPHEAD (BUCKEYE)
ELECTRIC (BR) FULL AIR CONDITIONING
6 PLUS 600 AMP WIRING
125
4.5
FLUORESCENT & TUNGSTEN
33
CENTRALLY SUPPORTED-SWIVELLING-FOAM DIAPHRAGM-STEEL FACE PLATE
PUBLIC ADDRESS
RETRACTABLE SPINDLE (559X356 OVAL)

TRACTION DATA FOR MULTIPLE UNITS

BASIC TYPE

AC 213 0A

VARIANTS

OB 100% NON SMOKING.

STANDARD OPEN-MK 11F

CLASS ---

TSO

AC 215

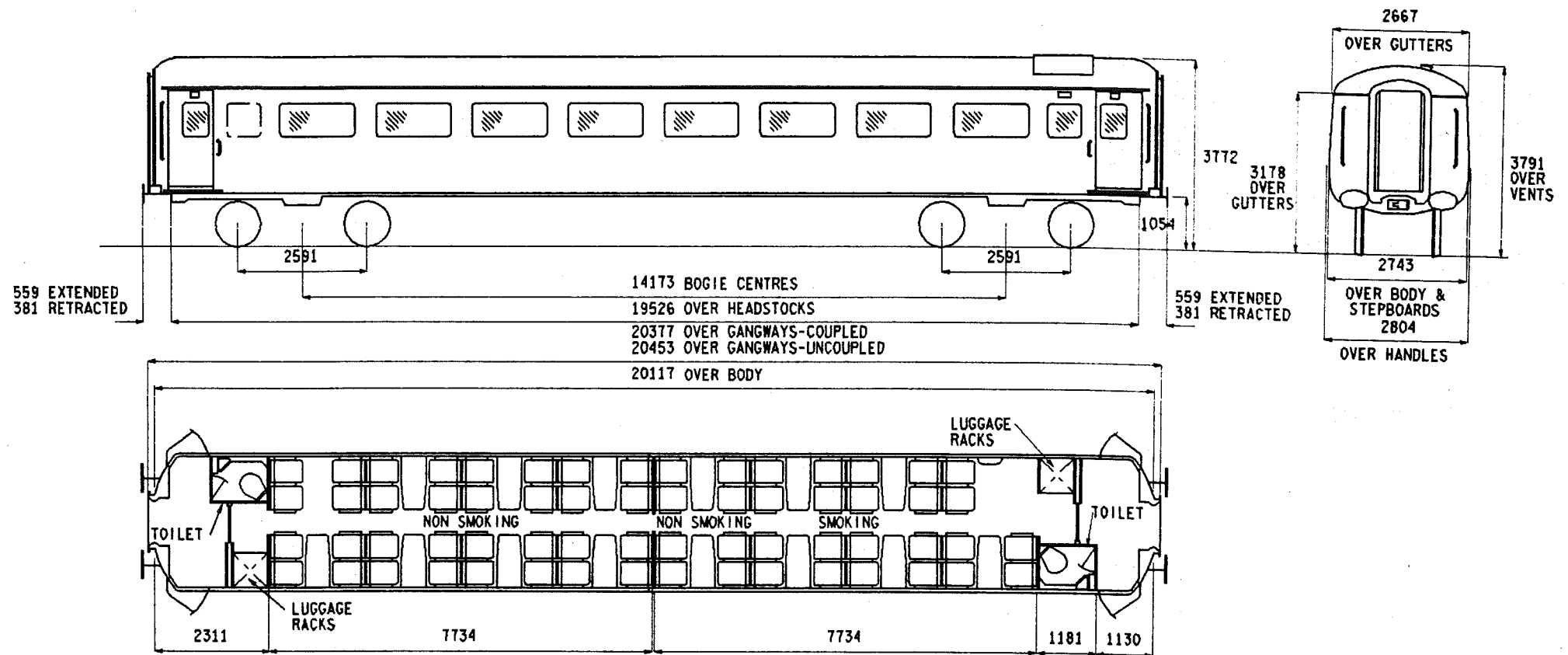

- SEATS 62
- TOILETS 2
- COMPARTMENTS -
- GUARDS COMPARTMENTS -
- VENTILATION FULL AIR CONDITIONING
- CATERING EQUIPMENT -

ORIGINAL DIAGRAMS FOR REFERENCE:-
BR 109

ISSUE 1 DATE JULY 89

AC 215

	<u>BASIC TYPE</u>	<u>ALTERNATIVES</u>
BRAKES	AIR	
BOGIE/SUSPENSION	B4	
BODY CONSTRUCTION	STEEL	
COUPLINGS	AUTOMATIC DROPHEAD(BUCKEYE)	
TRAIN HEATING	ELECTRIC(BR)FULL AIR CONDITIONING	
E.T.H. INDEX	5 PLUS 600 AMP WIRING	
MAX.SPEED M.P.H.	100	
MIN.RAD.CURVE CHAINS	3.5	
LIGHTING	FLUORESCENT & TUNGSTEN	
TARE WEIGHT TONNES	33.5	
GANGWAYS	PULLMAN	
TRAIN COMMUNICATION	PUBLIC ADDRESS	
BUFFERS	RETRACTABLE SPINDLE(559X356 OVAL)	
SEATS	STD. MK 11	1C 70
SMOKING ACCOMMODATION	62.5% NON SMOKING	

TRACTION DATA FOR MULTIPLE UNITSBASIC TYPE

AC 215 OA

VARIANTS

OB 1C 70 SEATS.

STANDARD OPEN-MK 111A

CLASS ---

TSO

AC 216

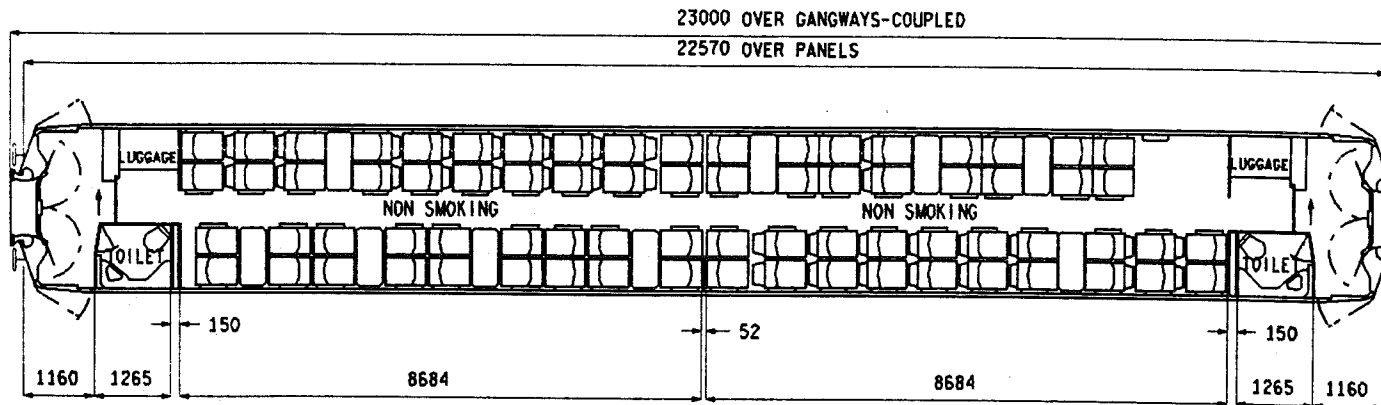
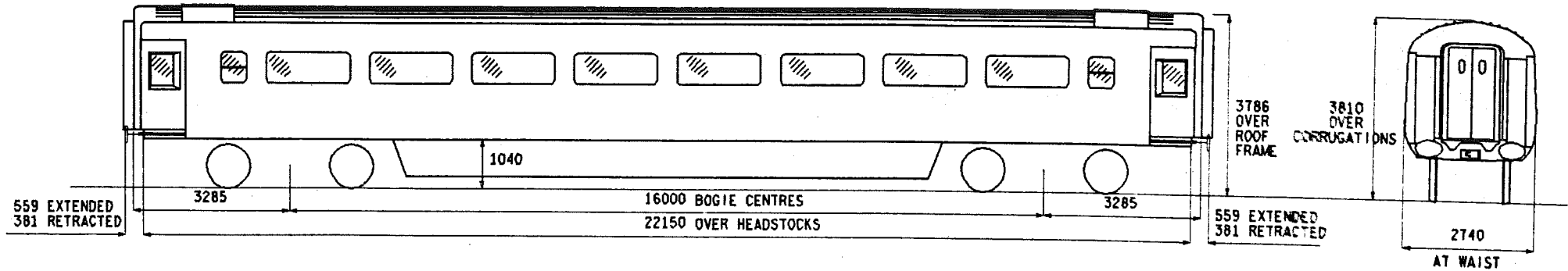

- SEATS 74
- TOILETS 2
- COMPARTMENTS -
- GUARDS COMPARTMENTS -
- VENTILATION FULL AIR CONDITIONING
- CATERING EQUIPMENT -

ISSUE DATE
1 JULY 89

AC 216

BRAKES
 BOGIE/SUSPENSION
 BODY CONSTRUCTION
 COUPLINGS
 TRAIN HEATING
 E.T.H. INDEX
 MAX. SPEED M.P.H.
 MIN. RAD. CURVE CHAINS
 LIGHTING
 TARE WEIGHT TONNES
 GANGWAYS
 TRAIN COMMUNICATION
 BUFFERS

BASIC TYPE

AIR
 BT10
 STEEL
 AUTOMATIC DROPHEAD(BUCKEYE)
 ELECTRIC(BR)FULL AIR CONDITIONING
 6 PLUS 600 AMP WIRING
 125
 4.5
 FLUORESCENT & TUNGSTEN
 33
 CENTRALLY SUPPORTED-SWIVELLING-FOAM DIAPHRAGM-STEEL FACE PLATE
 PUBLIC ADDRESS
 RETRACTABLE SPINDLE(559X356 OVAL)

ALTERNATIVES

BT7

4.1

TRACTION DATA FOR MULTIPLE UNITS

BASIC TYPE

AC 216 OA

VARIANTS

OB BT7 BOGIES,MIN.RAD.CURVE 4.1

MK 11D FO-TSO CONVERSION

CLASS ---

TSO

AC 217

20 MAR '92 14:25 FROM INTERCITY MAINTENANCE

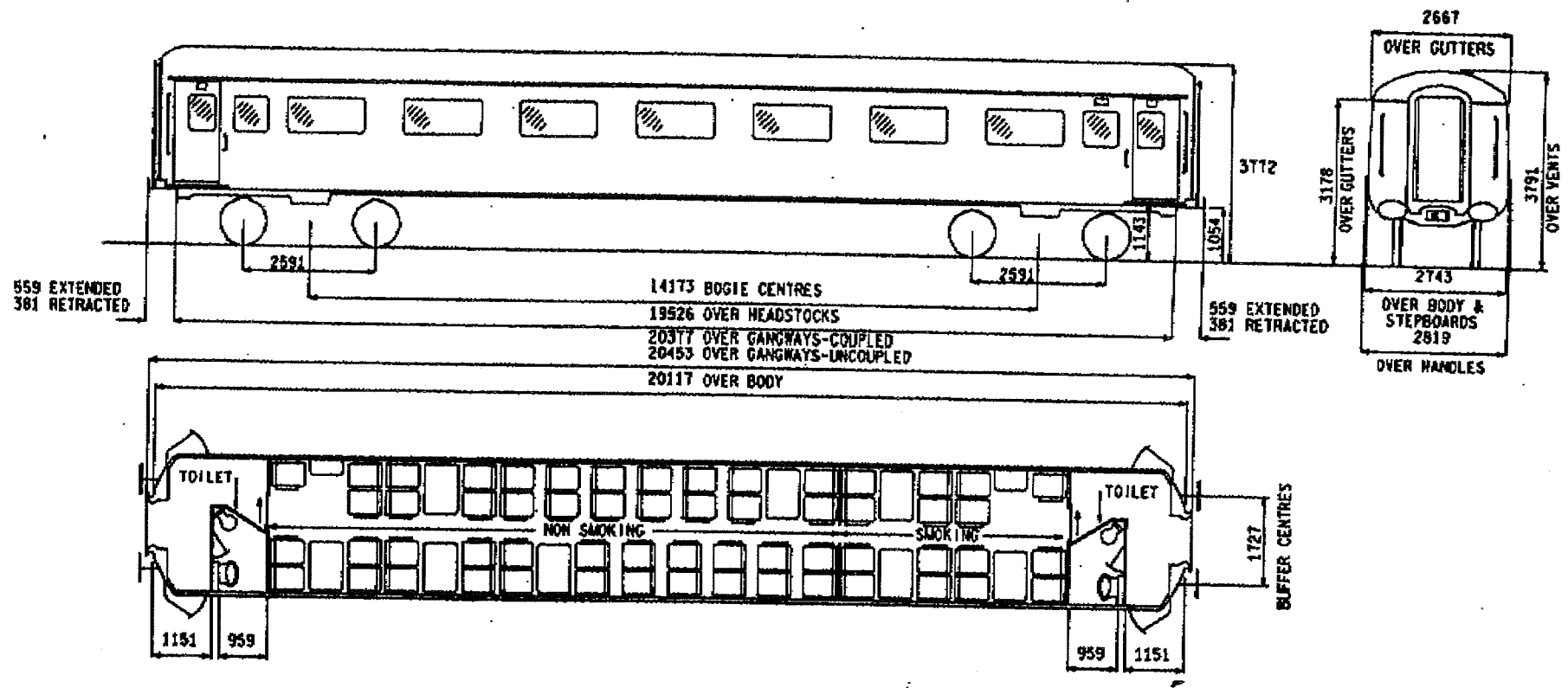

- SEATS 58
- TOILETS 2
- COMPARTMENTS
- GUARDS COMPARTMENTS
- VENTILATION
- CATERING EQUIPMENT
- FULL AIR CONDITIONING

ORIGINAL DIAGRAMS FOR REFERENCE:-
BR ---

ISSUE 1 DATE ~~1992~~

NOT YET ISSUED

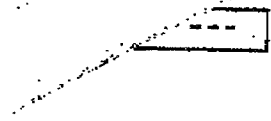

BRAKES
 BOGIE/SUSPENSION
 BODY CONSTRUCTION
 COUPLINGS
 TRAIN HEATING
 E.T.H. INDEX
 MAX. SPEED M.P.H.
 MIN. RAD. CURVE CHAINS
 LIGHTING
 TARE WEIGHT TONNES
 GANGWAYS
 TRAIN COMMUNICATION
 BUFFERS
 SMOKING ACCOMMODATION

BASIC TYPE

AIR
 B4
 STEEL
 AUTOMATIC DROPHEAD(BUCKEYE)
 ELECTRIC(BR)FULL AIR CONDITIONING NOT SUITED TO CLASS 55 LOCOM
 5
 100
 3.5
 FLUORESCENT & TUNGSTEN
 34
 PULLMAN
 PUBLIC ADDRESS
 RETRACTABLE SPINDLE(559X356 OVAL)
 56.0% NON SMOKING
 7A

ALTERNATIVES

MKID RESEATED SO

CLASS ---

AJ 104

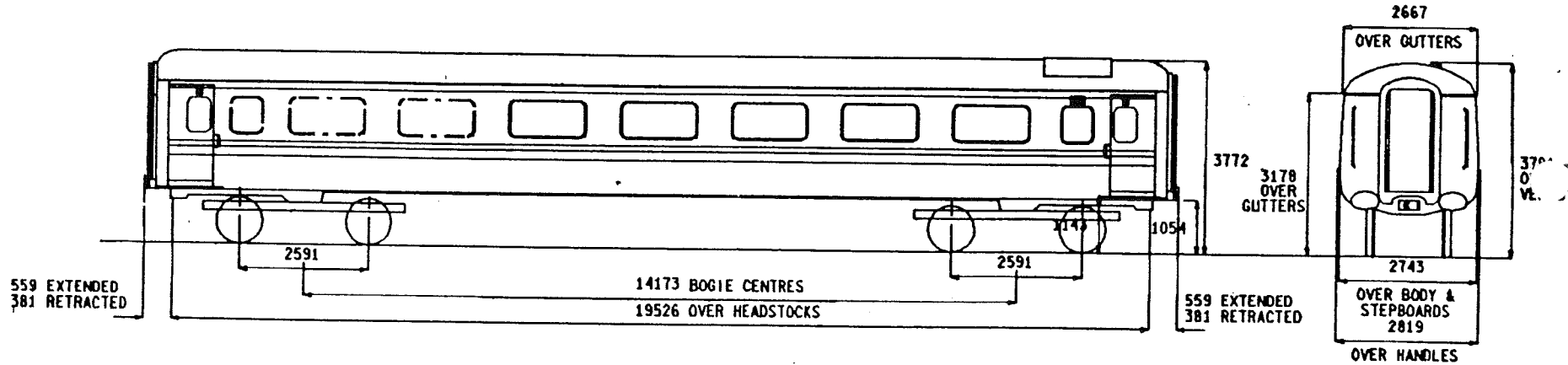

SEATING LAYOUT

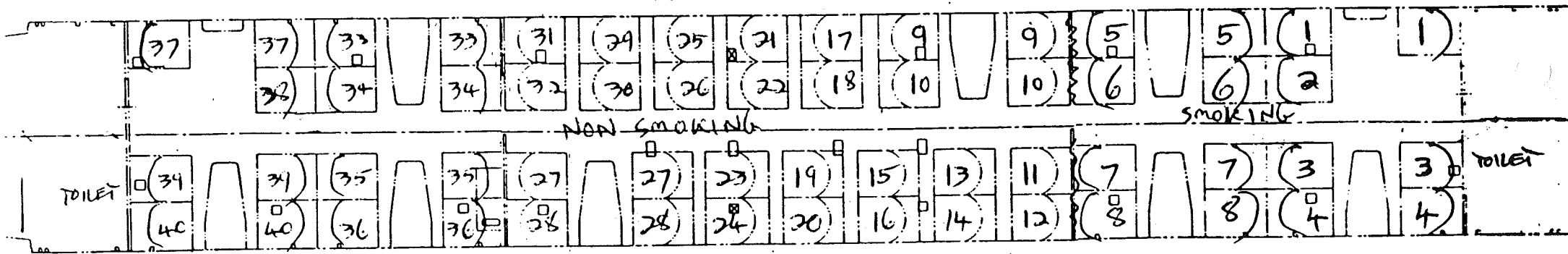

STANDARD OPEN-MK 11F

CLASS ---

TSO

AC 218

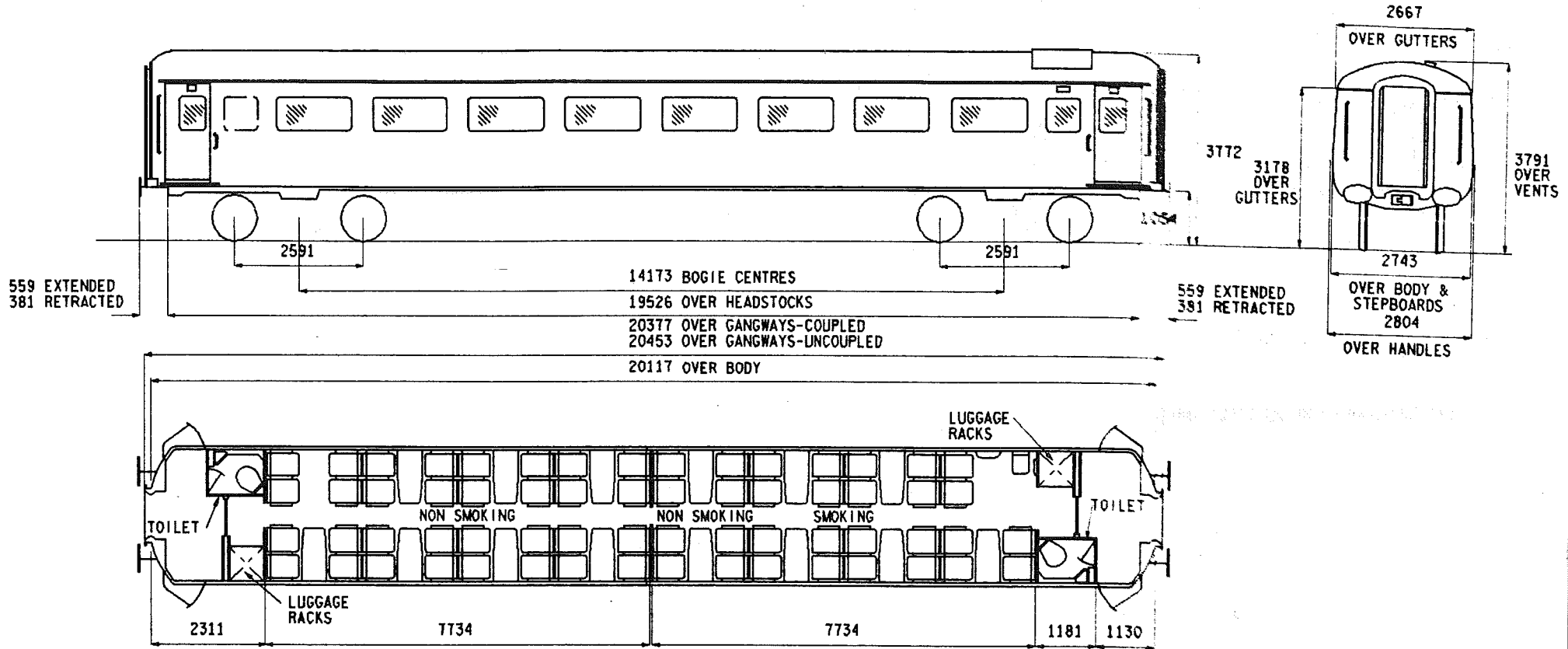

SEATS	63
TOILETS	2
COMPARTMENTS	-
GUARDS COMPARTMENTS	-
VENTILATION	FULL AIR CONDITIONING
CATERING EQUIPMENT	-

ORIGINAL DIAGRAMS FOR REFERENCE:-
BR 109

ISSUE 1 DATE JULY 89

AC 218

BRAKES
 BOGIE/SUSPENSION
 BODY CONSTRUCTION
 COUPLINGS
 TRAIN HEATING
 E.T.H. INDEX
 MAX. SPEED M.P.H.
 MIN. RAD. CURVE CHAINS
 LIGHTING
 TARE WEIGHT TONNES
 GANGWAYS
 TRAIN COMMUNICATION
 BUFFERS
 SEATS
 SMOKING ACCOMMODATION

BASIC TYPE

AIR
 B4
 STEEL
 AUTOMATIC DROPHEAD(BUCKEYE)
 ELECTRIC(BR)FULL AIR CONDITIONING
 5 PLUS 600 AMP WIRING
 100
 3.5
 FLUORESCENT & TUNGSTEN
 33.5
 PULLMAN
 PUBLIC ADDRESS
 RETRACTABLE SPINDLE(559X356 OVAL)
 STD. MK 11
 62.5% NON SMOKING

ALTERNATIVES

IC 70

TRACTION DATA FOR MULTIPLE UNITS

BASIC TYPE

AC 218 OA

VARIANTS

OB IC 70 SEATS.

STANDARD OPEN-MK 111A

CLASS ---

TSO

AC 219

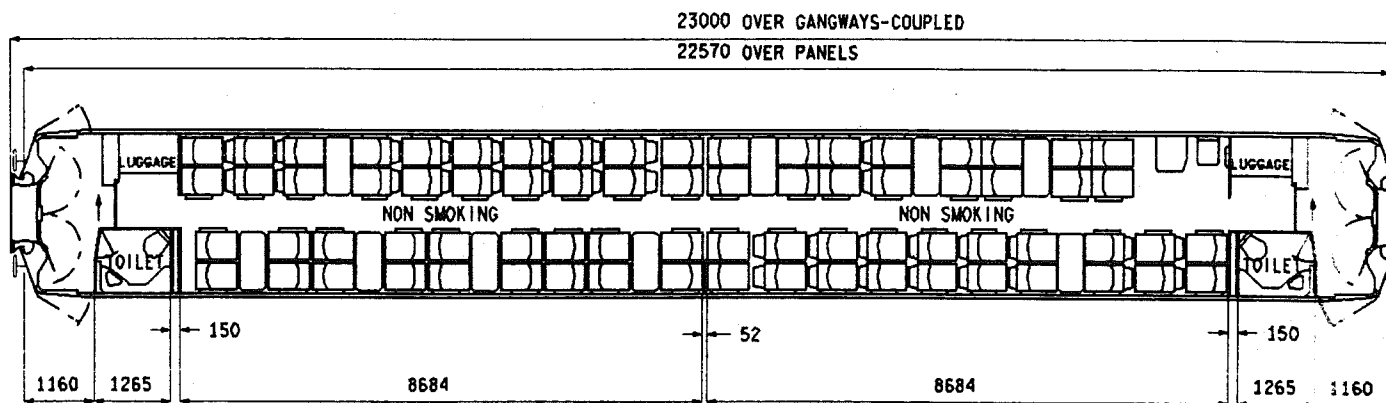
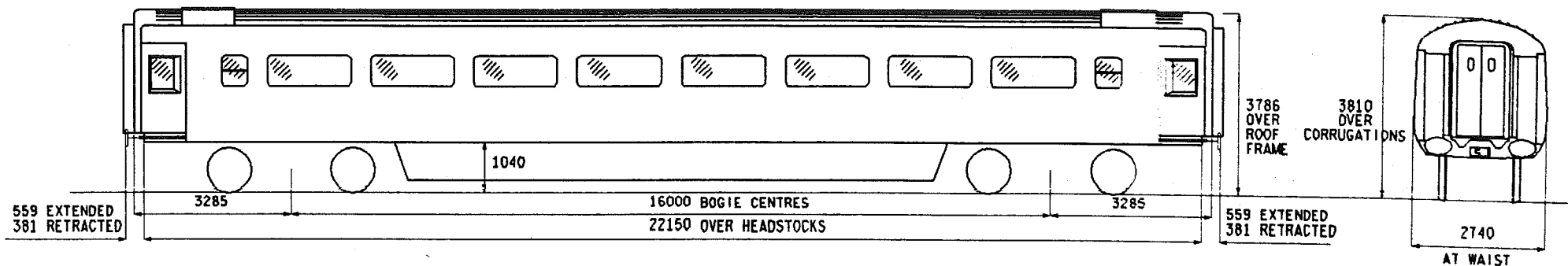

SEATS	75
TOILETS	2
COMPARTMENTS	-
GUARDS COMPARTMENTS	-
VENTILATION	FULL AIR CONDITIONING
CATERING EQUIPMENT	-

ISSUE	DATE
1	JULY 89

AC 219

BASIC TYPE

ALTERNATIVES

BRAKES
BOGIE/SUSPENSION
BODY CONSTRUCTION
COUPLINGS
TRAIN HEATING
E.T.H. INDEX
MAX. SPEED M.P.H.
MIN. RAD. CURVE CHAINS
LIGHTING
TARE WEIGHT TONNES
GANGWAYS
TRAIN COMMUNICATION
BUFFERS

AIR
BT10
STEEL
AUTOMATIC DROPHEAD(BUCKEYE)
ELECTRIC(BR)FULL AIR CONDITIONING
6 PLUS 600 AMP WIRING
125
4.5
FLUORESCENT & TUNGSTEN
33
CENTRALLY SUPPORTED-SWIVELLING-FOAM DIAPHRAGM-STEEL FACE PLATE
PUBLIC ADDRESS
RETRACTABLE SPINDLE(559X356 OVAL)

TRACTION DATA FOR MULTIPLE UNITS

BASIC TYPE

AC 219 OA

VARIANTS

STANDARD OPEN-MK 111A

CLASS ---

TSO

AC 220

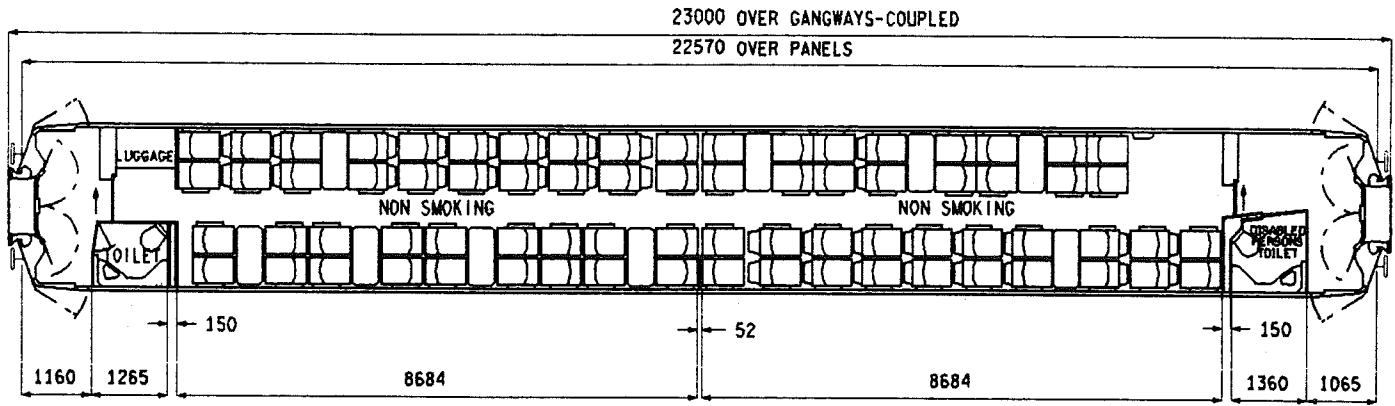
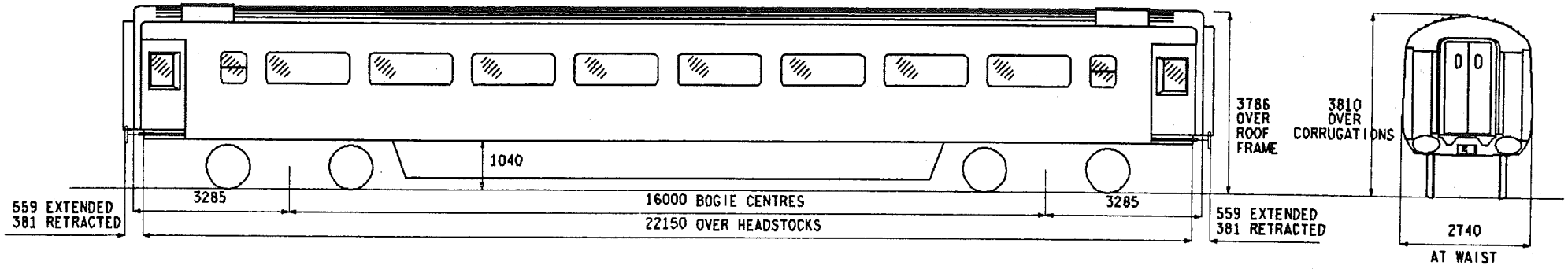

- | | |
|---------------------|-----------------------|
| SEATS | 74 |
| TOILETS | 2 |
| COMPARTMENTS | - |
| GUARDS COMPARTMENTS | - |
| VENTILATION | FULL AIR CONDITIONING |
| CATERING EQUIPMENT | - |

ISSUE DATE
1 JULY 89

AC 220

	<u>BASIC TYPE</u>	<u>ALTERNATIVES</u>
BRAKES	AIR	
BOGIE/SUSPENSION	BT10	BTT
BODY CONSTRUCTION	STEEL	
COUPLINGS	AUTOMATIC DROPHEAD(BUCKEYE)	
TRAIN HEATING	ELECTRIC(BR)FULL AIR CONDITIONING	
E.T.H. INDEX	6 PLUS 600 AMP WIRING	
MAX.SPEED M.P.H.	125	
MIN.RAD.CURVE CHAINS	4.5	4.1
LIGHTING	FLUORESCENT & TUNGSTEN	
TARE WEIGHT TONNES	33	
GANGWAYS	CENTRALLY SUPPORTED-SWIVELLING-FOAM DIAPHRAGM-STEEL FACE PLATE	
TRAIN COMMUNICATION	PUBLIC ADDRESS	
BUFFERS	RETRACTABLE SPINDLE(559X356 OVAL)	

TRACTION DATA FOR MULTIPLE UNITSBASIC TYPE

AC 220 OA

VARIANTS

OB BTT BOGIES,MIN.RAD.CURVE 4.1

STANDARD OPEN-MK 111A

CLASS ---

TSO

AC 221

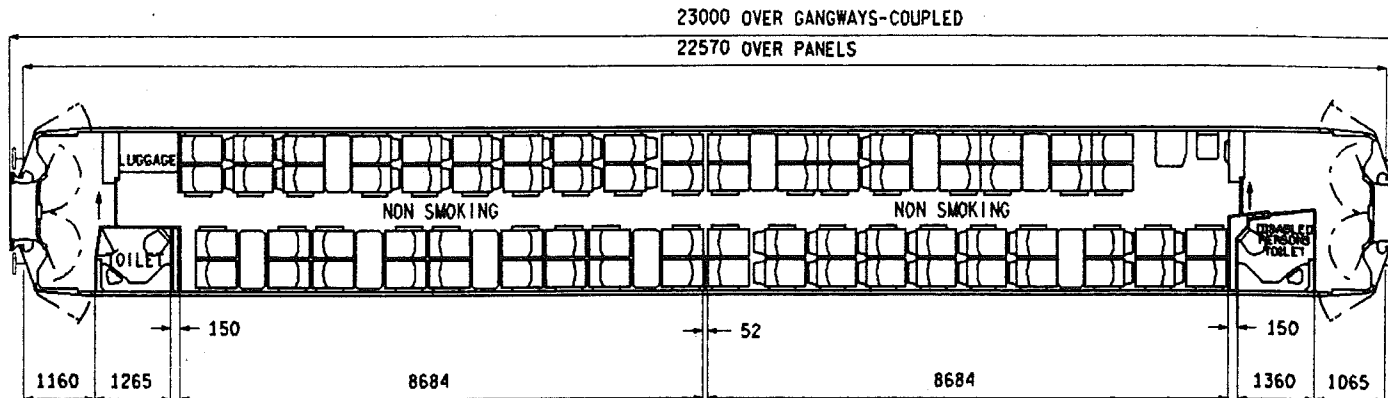
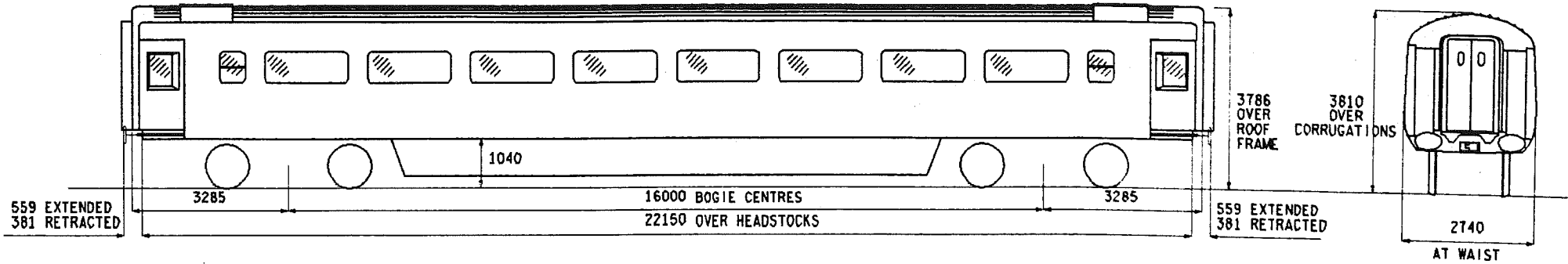

- SEATS 75
- TOILETS 2
- COMPARTMENTS -
- GUARDS COMPARTMENTS -
- VENTILATION FULL AIR CONDITIONING
- CATERING EQUIPMENT -

ISSUE 1 DATE JULY 89

AC 221

BRAKES
 BOGIE/SUSPENSION
 BODY CONSTRUCTION
 COUPLINGS
 TRAIN HEATING
 E.T.H. INDEX
 MAX. SPEED M.P.H.
 MIN. RAD. CURVE CHAINS
 LIGHTING
 TARE WEIGHT TONNES
 GANGWAYS
 TRAIN COMMUNICATION
 BUFFERS

BASIC TYPE

AIR
 BT10
 STEEL
 AUTOMATIC DROPHEAD (BUCKEYE)
 ELECTRIC (BR) FULL AIR CONDITIONING
 6 PLUS 600 AMP WIRING
 125
 4.5
 FLUORESCENT & TUNGSTEN
 33
 CENTRALLY SUPPORTED-SWIVELLING-FOAM DIAPHRAGM-STEEL FACE PLATE
 PUBLIC ADDRESS
 RETRACTABLE SPINDLE (559X356 OVAL)

ALTERNATIVES

BT7

4.1

TRACTION DATA FOR MULTIPLE UNITSBASIC TYPE

AC 221 OA

VARIANTS

OB BT7 BOGIES, MIN. RAD. CURVE 4.1

STANDARD OPEN-MK 111A

CLASS ---

TSO

AC 222

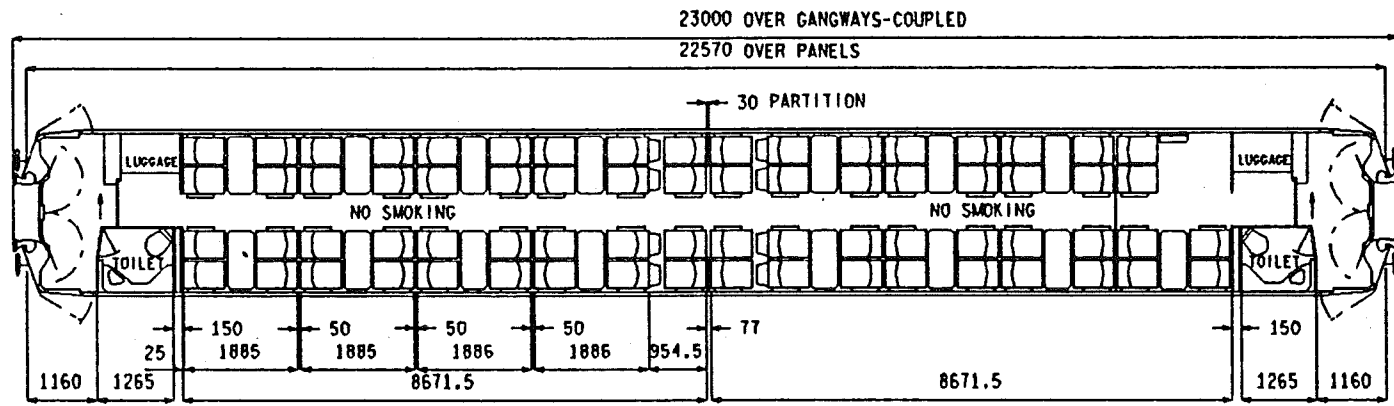
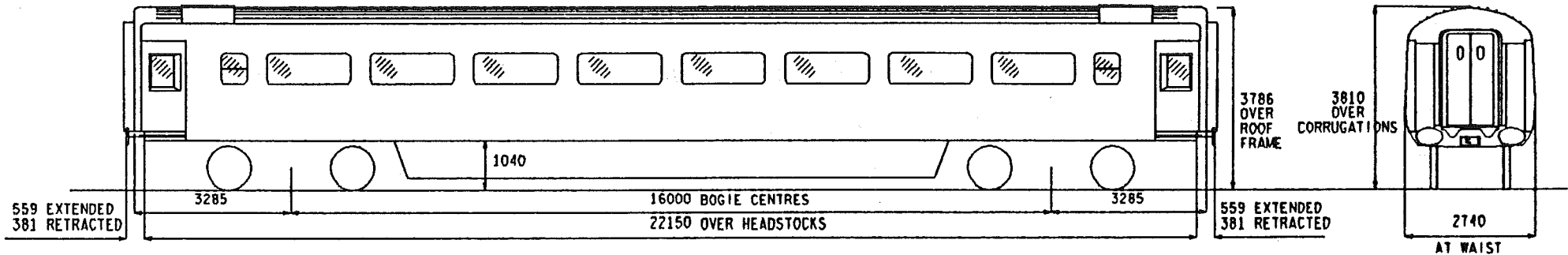

- SEATS 70
- TOILETS 2
- COMPARTMENTS -
- GUARDS COMPARTMENTS -
- VENTILATION FULL AIR CONDITIONING
- CATERING EQUIPMENT -

ORIGINAL DIAGRAMS FOR REFERENCE:-
BR 111

ISSUE 1 DATE JULY 89

AC 222

BASIC TYPE

ALTERNATIVES

BRAKES
BOGIE/SUSPENSION
BODY CONSTRUCTION
COUPLINGS
TRAIN HEATING
E.T.H. INDEX
MAX.SPEED M.P.H.
MIN.RAD.CURVE CHAINS
LIGHTING
TARE WEIGHT TONNES
GANGWAYS

AIR
BT10
STEEL
AUTOMATIC DROPHEAD(BUCKEYE)
ELECTRIC(BR)FULL AIR CONDITIONING
6 PLUS 600 AMP WIRING
125
4.5
FLUORESCENT & TUNGSTEN
33
CENTRALLY SUPPORTED-SWIVELLING-FOAM DIAPHRAGM-STEEL FACE PLATE
PUBLIC ADDRESS
RETRACTABLE SPINDLE(559X356 OVAL)

TRAIN COMMUNICATION
BUFFERS

TRACTION DATA FOR MULTIPLE UNITS

BASIC TYPE

AC 222 0A

VARIANTS

STANDARD OPEN-MK 111A

CLASS ---

TSO

AC 223

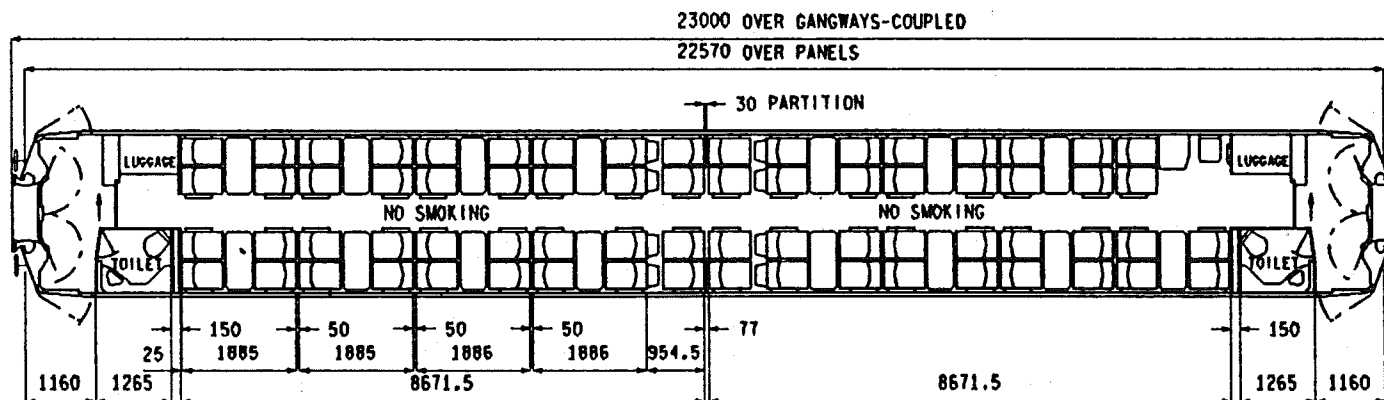
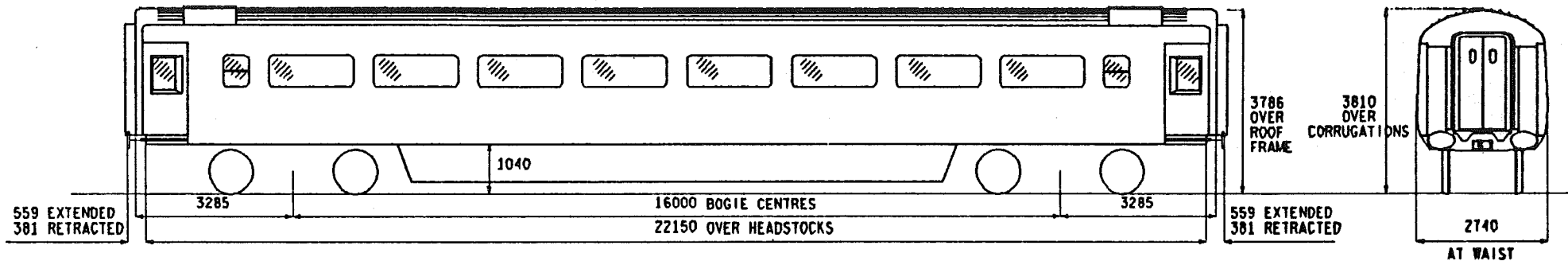

- SEATS 71
- TOILETS 2
- COMPARTMENTS -
- GUARDS COMPARTMENTS -
- VENTILATION FULL AIR CONDITIONING
- CATERING EQUIPMENT -

ORIGINAL DIAGRAMS FOR REFERENCE 1-
BR 111

ISSUE 1 DATE JUL 89

AC 223

BASIC TYPE

ALTERNATIVES

BRAKES
BOGIE/SUSPENSION
BODY CONSTRUCTION
COUPLINGS
TRAIN HEATING
E.T.H. INDEX
MAX.SPEED M.P.H.
MIN.RAD.CURVE CHAINS
LIGHTING
TARE WEIGHT TONNES
GANGWAYS

AIR
BT10
STEEL
AUTOMATIC DROPHEAD(BUCKEYE)
ELECTRIC(BR)FULL AIR CONDITIONING
6 PLUS 600 AMP WIRING
125
4.5
FLUORESCENT & TUNGSTEN
33
CENTRALLY SUPPORTED-SWIVELLING-FOAM DIAPHRAGM-STEEL FACE PLATE

PUBLIC ADDRESS
RETRACTABLE SPINDLE(559X356 OVAL)

TRAIN COMMUNICATION
BUFFERS

TRACTION DATA FOR MULTIPLE UNITS

BASIC TYPE
AC 223 OA

VARIANTS

CLASS ---

FO

AD 103

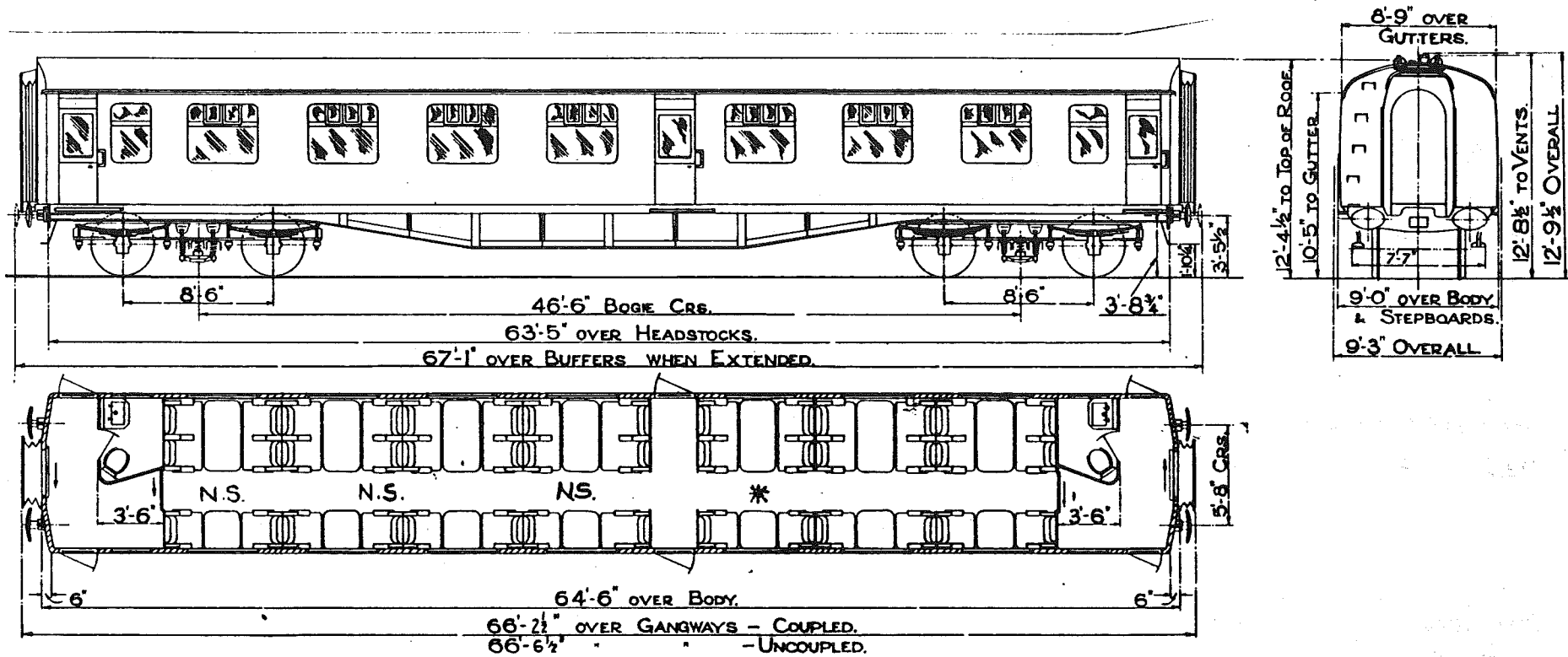

CENTRE DOORS SEALED & SERVING
 TABLES ADDED FOR CHARTER TRAIN
 VEHICLES-SEE VARIANTS

THIS BAY N.S. ON
 SOME VEHICLES.SEE VARIANTS

N.S.- NON SMOKING

SEATS	42
TOILETS	2
COMPARTMENTS	-
GUARDS COMPARTMENTS	-
VENTILATION	-
CATERING EQUIPMENT	-

ORIGINAL DIAGRAMS FOR REFERENCE-
 BR 73

ISSUE 8 DATE MAY 89

AD 103

BRAKES
 BOGIE/SUSPENSION
 BODY CONSTRUCTION
 COUPLINGS
 TRAIN HEATING
 E.T.H. INDEX
 MAX. SPEED M.P.H.
 MIN. RAD. CURVE CHAINS
 LIGHTING
 TARE WEIGHT TONNES
 GANGWAYS
 TRAIN COMMUNICATION
 BUFFERS
 BRAKE BLOCKS
 SMOKING ACCOMMODATION

BASIC TYPE

VACUUM
 COMMONWEALTH
 STEEL
 AUTOMATIC DROPHEAD(BUCKEYE)
 DUAL(STEAM/ELECTRIC(BR))
 3
 100
 3.5
 TUNGSTEN
 33.5
 PULLMAN
 NOT FITTED
 RETRACTABLE SPINDLE(559X356 OVAL)
 CAST IRON
 57% NON SMOKING

ALTERNATIVES

AIR,VACUUM & AIR
 B4

 ELECTRIC(BR)
 3 WITH 675 VOLT HEATERS
 90

 FLUORESCENT & TUNGSTEN
 35

 PUBLIC ADDRESS

 COMPOSITION
 71% NON SMOKING

TRACTION DATA FOR MULTIPLE UNITSBASIC TYPE

AD 103 1A

VARIANTS

1C B4 BOGIES,71% NON SMOKING
 1G COMPOSITION BRAKE BLOCKS.
 1H B4 BOGIES,COMPOSITION BRAKE BLOCKS
 1K 71% NON SMOKING.
 1L B4 BOGIES,COMPOSITION BRAKE BLOCKS,71% NON SMOKING
 1Q VACUUM & AIR BRAKES,B4 BOGIES,COMPOSITION BRAKE BLOCKS,71% NON SMOKING
 2D VACUUM & AIR BRAKES,FLUORESCENT & TUNGSTEN LIGHTING,PUBLIC ADDRESS,71% NON SMOKING
 3F ELECTRIC(BR)HEATING,AIR BRAKES,E.T.H.3 WITH 675 VOLT HEATERS,B4 BOGIES,MAX.SPEED 90.
 4A FLUORESCENT & TUNGSTEN LIGHTING.
 4D VACUUM & AIR BRAKES,FLUORESCENT & TUNGSTEN LIGHTING.
 4H B4 BOGIES,COMPOSITION BRAKE BLOCKS,FLUORESCENT & TUNGSTEN LIGHTING.
 4J AIR BRAKES,FLUORESCENT & TUNGSTEN LIGHTING.
 4K FLUORESCENT & TUNGSTEN LIGHTING,71% NON SMOKING
 4L B4 BOGIES,COMPOSITION BRAKE BLOCKS,71% NON SMOKING,FLUORESCENT & TUNGSTEN LIGHTING.
 4M VACUUM & AIR BRAKES,FLUORESCENT & TUNGSTEN LIGHTING,71% NON SMOKING
 4N AIR BRAKES,FLUORESCENT & TUNGSTEN LIGHTING.
 4D VACUUM & AIR BRAKES B4 BOGIES,COMPOSITION BRAKE BLOCKS,71% NON SMOKING,FLUORESCENT & TUNGSTEN LIGHTING.
 5N AIR BRAKES,FLUORESCENT & TUNGSTEN LIGHTING,MODIFIED FOR CHARTER TRAIN.
 5P AIR BRAKES,FLUORESCENT & TUNGSTEN LIGHTING,TARE 35,MODIFIED FOR CHARTER TRAIN.

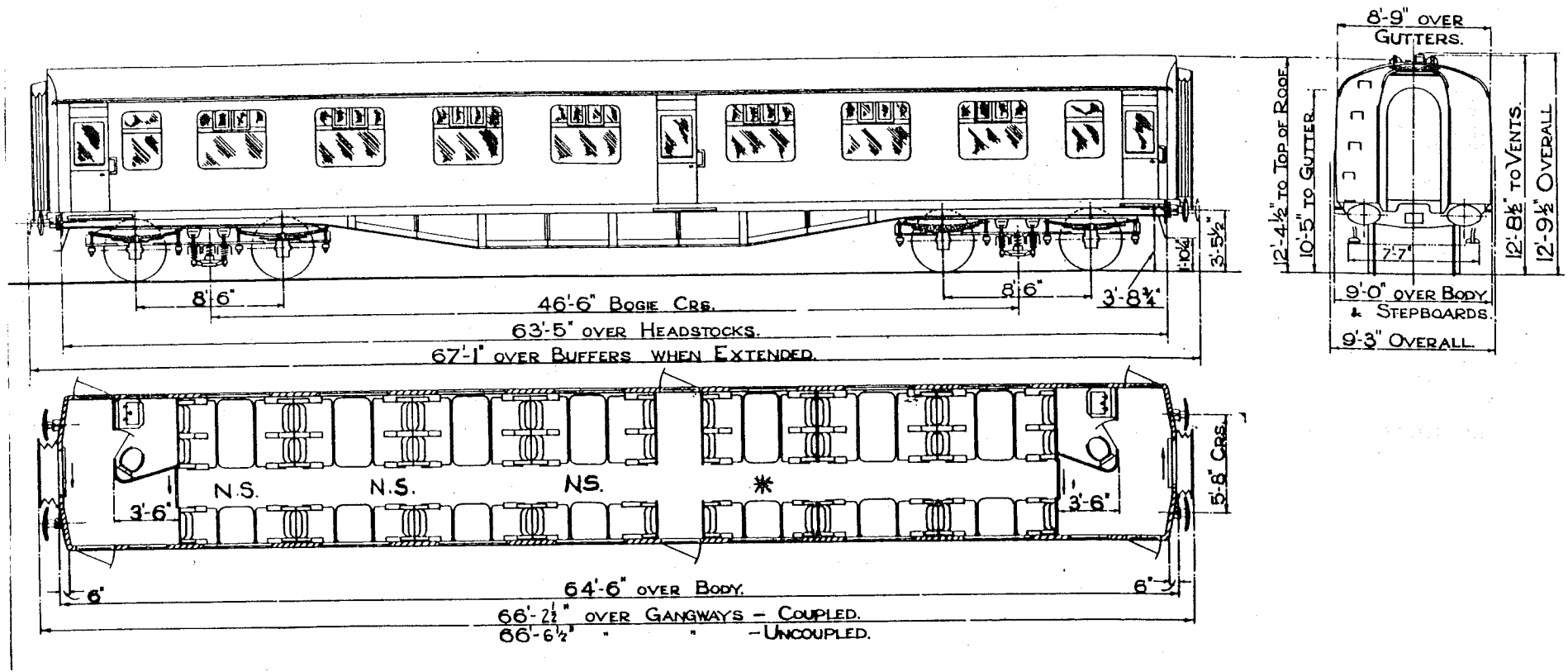

CENTRE DOORS SEALED & SERVING
 TABLES ADDED FOR CHARTER TRAIN
 VEHICLES-SEE VARIANTS

* THIS BAY N.S. ON
 SOME VEHICLES.SEE VARIANTS

N.S.- NON SMOKING

SEATS	42
TOILETS	2
COMPARTMENTS	-
GUARDS COMPARTMENTS	-
VENTILATION	-
CATERING EQUIPMENT	-

ORIGINAL DIAGRAMS FOR REFERENCE:-
 BR 73

ISSUE DATE
 7 NOV 87

AD 103

BRAKES
BOGIE/SUSPENSION
BODY CONSTRUCTION
COUPLINGS
TRAIN HEATING
E.T.H. INDEX
MAX.SPEED M.P.H.
MIN.RAD.CURVE CHAINS
LIGHTING
TARE WEIGHT TONNES
GANGWAYS
TRAIN COMMUNICATION
BUFFERS
BRAKE BLOCKS
SMOKING ACCOMMODATION

BASIC TYPE

VACUUM
COMMONWEALTH
STEEL
AUTOMATIC DROPHEAD(BUCKEYE)
DUAL(STEAM/ELECTRIC(BR))
3
100
3.5
TUNGSTEN
33.5
PULLMAN
NOT FITTED
RETRACTABLE SPINDLE(559X356 OVAL)
CAST IRON
57% NON SMOKING

ALTERNATIVES

AIR,VACUUM & AIR
B4

ELECTRIC(BR)
3 WITH 675 VOLT HEATERS
90

FLUORESCENT & TUNGSTEN
35

PUBLIC ADDRESS

COMPOSITION
71% NON SMOKING

TRACTION DATA FOR MULTIPLE UNITSBASIC TYPE

AD 103 1A

VARIANTS

1C B4 BOGIES,71% NON SMOKING
1G COMPOSITION BRAKE BLOCKS.
1H B4 BOGIES,COMPOSITION BRAKE BLOCKS
1K 71% NON SMOKING.
1L B4 BOGIES,COMPOSITION BRAKE BLOCKS,71% NON SMOKING
2D VACUUM & AIR BRAKES,FLUORESCENT & TUNGSTEN LIGHTING,PUBLIC ADDRESS,71% NON SMOKING
3F ELECTRIC(BR)HEATING,AIR BRAKES,E.T.H.3 WITH 675 VOLT HEATERS,B4 BOGIES,MAX.SPEED 90.
4A FLUORESCENT & TUNGSTEN LIGHTING.
4D VACUUM & AIR BRAKES,FLUORESCENT & TUNGSTEN LIGHTING.
4H B4 BOGIES,COMPOSITION BRAKE BLOCKS,FLUORESCENT & TUNGSTEN LIGHTING.
4J AIR BRAKES,FLUORESCENT & TUNGSTEN LIGHTING.
4K FLUORESCENT & TUNGSTEN LIGHTING,71% NON SMOKING
4L B4 BOGIES,COMPOSITION BRAKE BLOCKS,71% NON SMOKING,FLUORESCENT & TUNGSTEN LIGHTING.
4M VACUUM & AIR BRAKES,FLUORESCENT & TUNGSTEN LIGHTING,71% NON SMOKING
5N AIR BRAKES,FLUORESCENT & TUNGSTEN LIGHTING,MODIFIED FOR CHARTER TRAIN.
5P AIR BRAKES,FLUORESCENT & TUNGSTEN LIGHTING,TARE 35,MODIFIED FOR CHARTER TRAIN.

FIRST OPEN-MK 11C

CLASS ---

FO

AD 104

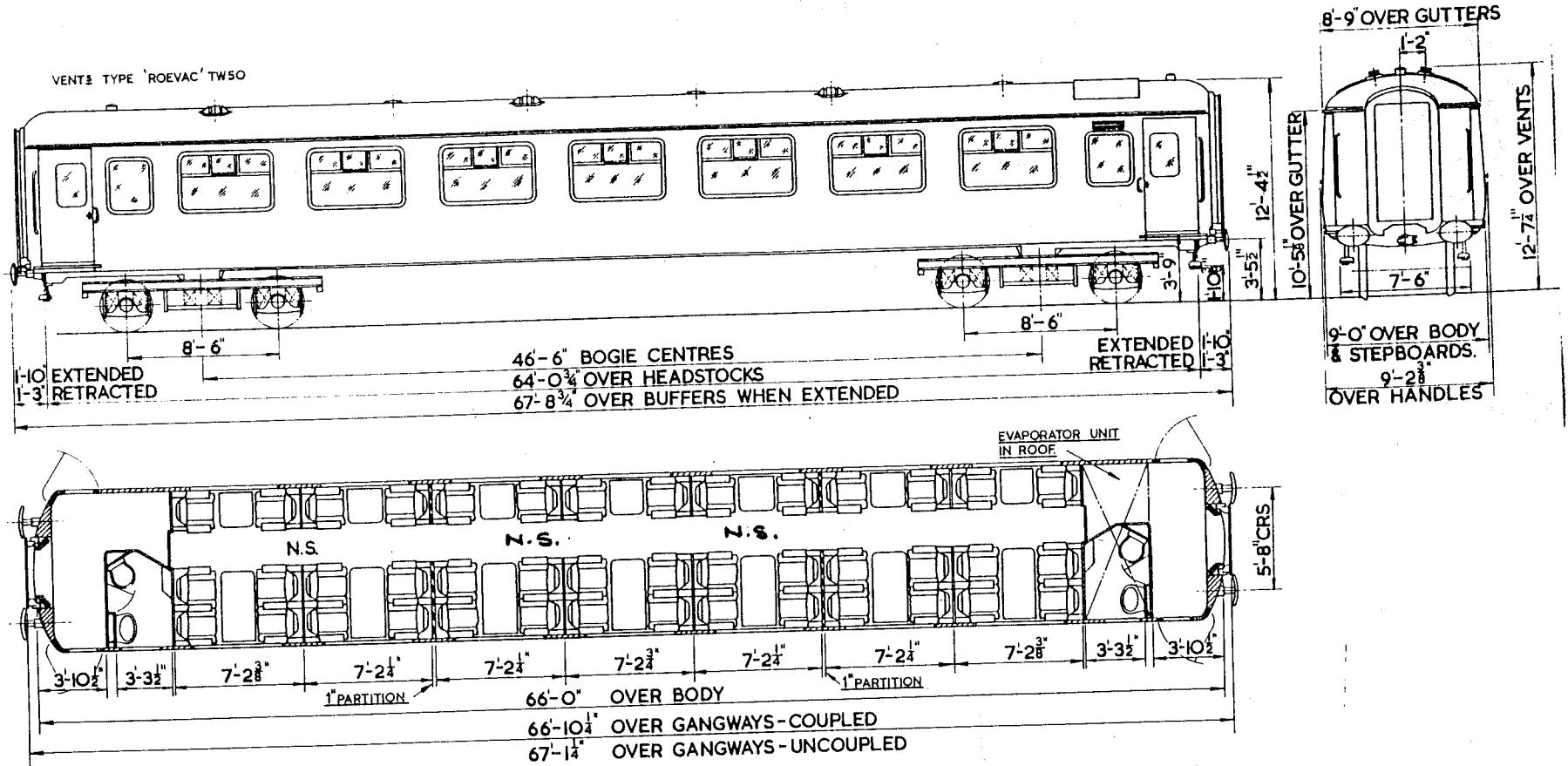

SEATS	42
TOILETS	2
COMPARTMENTS	-
GUARDS COMPARTMENTS	-
VENTILATION	PRESSURE
CATERING EQUIPMENT	-

ORIGINAL DIAGRAMS FOR REFERENCE:-
BR 80

ISSUE 4 DATE DEC 85

AD 104

BASIC TYPE

BRAKES
BOGIE/SUSPENSION
BODY CONSTRUCTION
COUPLINGS
TRAIN HEATING
E.T.H. INDEX
MAX. SPEED M.P.H.
MIN. RAD. CURVE CHAINS
LIGHTING
TARE WEIGHT TONNES
GANGWAYS
TRAIN COMMUNICATION
BUFFERS
BRAKE BLOCKS

AIR
B4
STEEL
AUTOMATIC DROPHEAD(BUCKEYE)
DUAL(STEAM/ELECTRIC(BR))WITH PRES SURE VENTILATION & HEATING
4
100
3.5
FLUORESCENT & TUNGSTEN
33
PULLMAN
PUBLIC ADDRESS
RETRACTABLE SPINDLE(559X356 OVAL)
CAST IRON

ALTERNATIVES

TRACTION DATA FOR MULTIPLE UNITS

BASIC TYPE

AD 104 0A

VARIANTS

NONE

FIRST OPEN-MK IID

CLASS ----

FO

AD 105

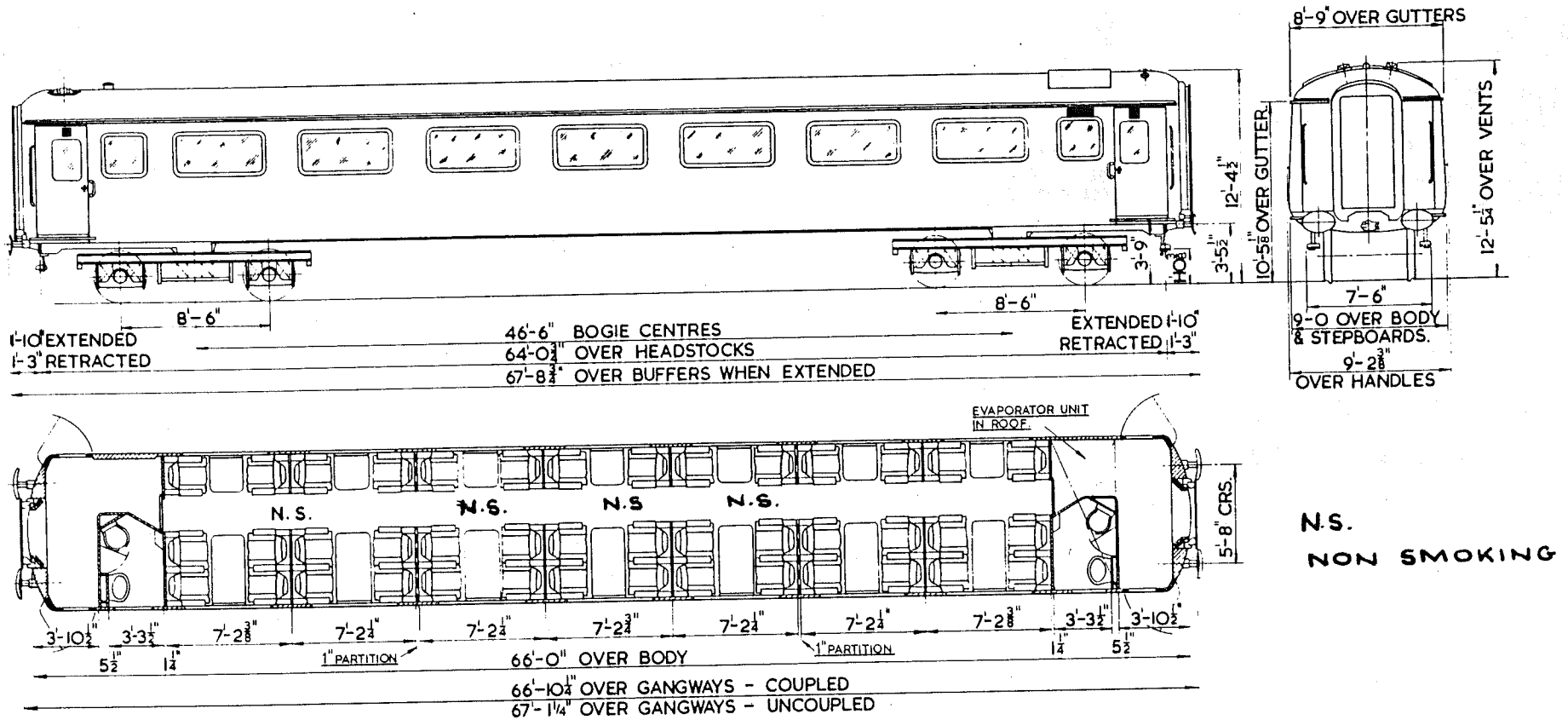

N.S.
NON SMOKING

SEATS	42
TOILETS	2
COMPARTMENTS	-
GUARDS COMPARTMENTS	-
VENTILATION	FULL AIR CONDITIONING
CATERING EQUIPMENT	-

ORIGINAL DIAGRAMS FOR REFERENCE.-
BR 81

ISSUE 2 DATE OCT '81

AD 105

BASIC TYPE

BRAKES
BOGIE/SUSPENSION
BODY CONSTRUCTION
COUPLINGS
TRAIN HEATING
E.T.H. INDEX
MAX. SPEED M.P.H.
MIN. RAD. CURVE CHAINS
LIGHTING
TARE WEIGHT TONNES
GANGWAYS
TRAIN COMMUNICATION
BUFFERS

AIR
B4
STEEL
AUTOMATIC DROPHEAD (BUCKEYE)
ELECTRIC (BR) FULL AIR CONDITIONING-NOT SUITED TO CLASS 55 LOCOS
5
100
3.5
FLUORESCENT & TUNGSTEN
34
PULLMAN
PUBLIC ADDRESS
RETRACTABLE SPINDLE (559X356 OVAL)

ALTERNATIVES

ELECTRIC (BR) FULL AIR CONDITIONING

TRACTION DATA FOR MULTIPLE UNITS

BASIC TYPE

AD 105 0A

VARIANTS

1A ELECTRIC (BR) FULL AIR CONDITIONING.

FIRST OPEN-MK IIE

CLASS ---

FO

AD 106

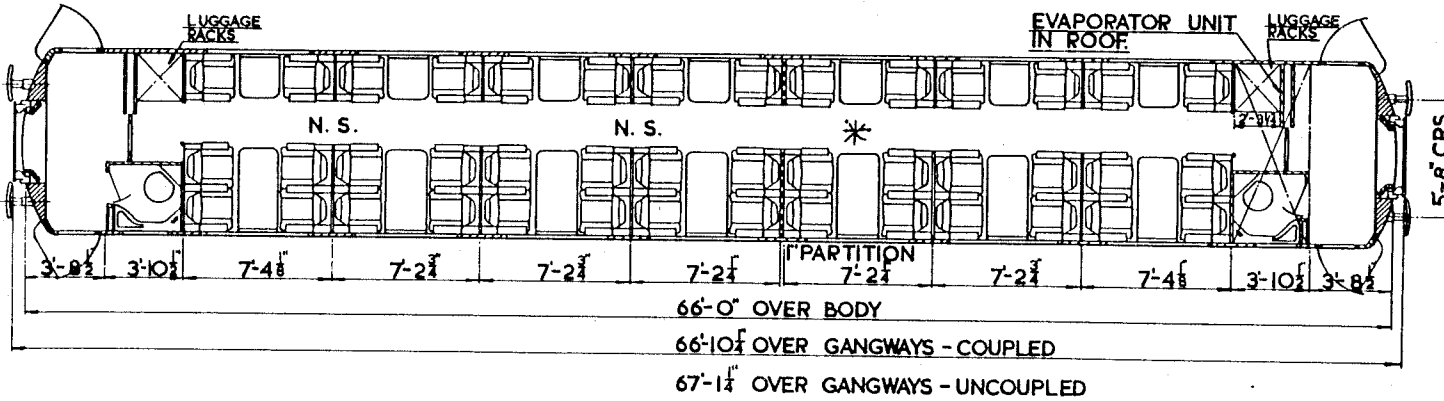
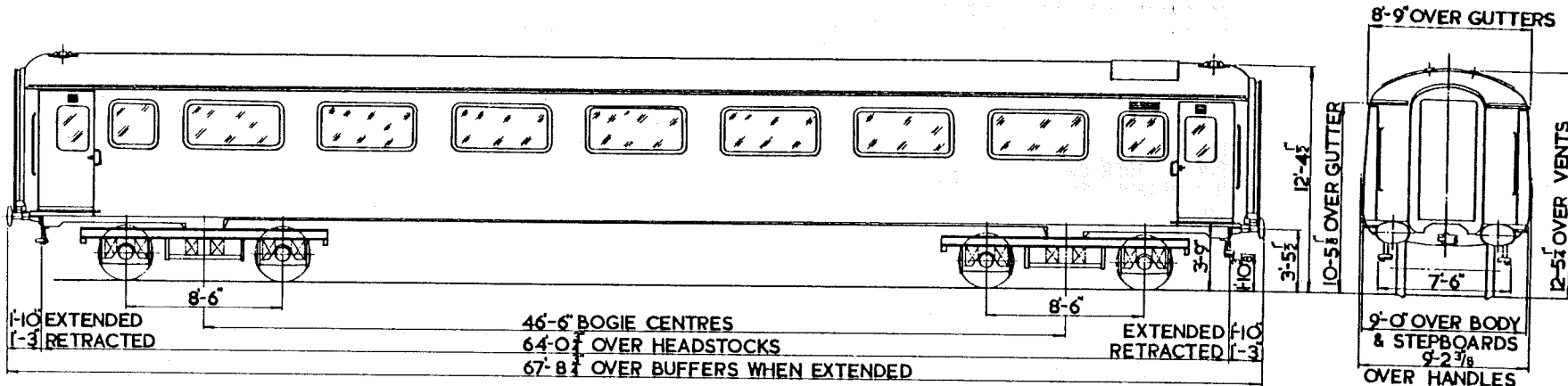

N.S. - NON SMOKING

* THIS BAY N.S. ON SOME VEHICLES. SEE VARIANTS

SEATS	42
TOILETS	2
COMPARTMENTS	-
GUARDS COMPARTMENTS	-
VENTILATION	FULL AIR CONDITIONING
CATERING EQUIPMENT	-

ORIGINAL DIAGRAMS FOR REFERENCE:-
 BR 82

ISSUE 3 DATE OCT '86

AD 106

BRAKES
 BOGIE/SUSPENSION
 BODY CONSTRUCTION
 COUPLINGS
 TRAIN HEATING
 E.T.H. INDEX
 MAX. SPEED M.P.H.
 MIN. RAD. CURVE CHAINS
 LIGHTING
 TARE WEIGHT TONNES
 GANGWAYS
 TRAIN COMMUNICATION
 BUFFERS
 SMOKING ACCOMMODATION

BASIC TYPE

AIR
 B4
 STEEL
 AUTOMATIC DROPHEAD(BUCKEYE)
 ELECTRIC(BR)FULL AIR CONDITIONING-NOT SUITED TO CLASS 55 DELTIC LOCOS
 5
 100
 3.5
 FLUORESCENT & TUNGSTEN
 34
 PULLMAN
 PUBLIC ADDRESS
 RETRACTABLE SPINDLE(559X356 OVAL)
 50% NON SMOKING

ALTERNATIVES

71% NON SMOKING

TRACTION DATA FOR MULTIPLE UNITS

BASIC TYPE

AD 106 OA

VARIANTS

OB 71% NON SMOKING

FIRST OPEN-MK 11F

CLASS ---

F0

AD 107

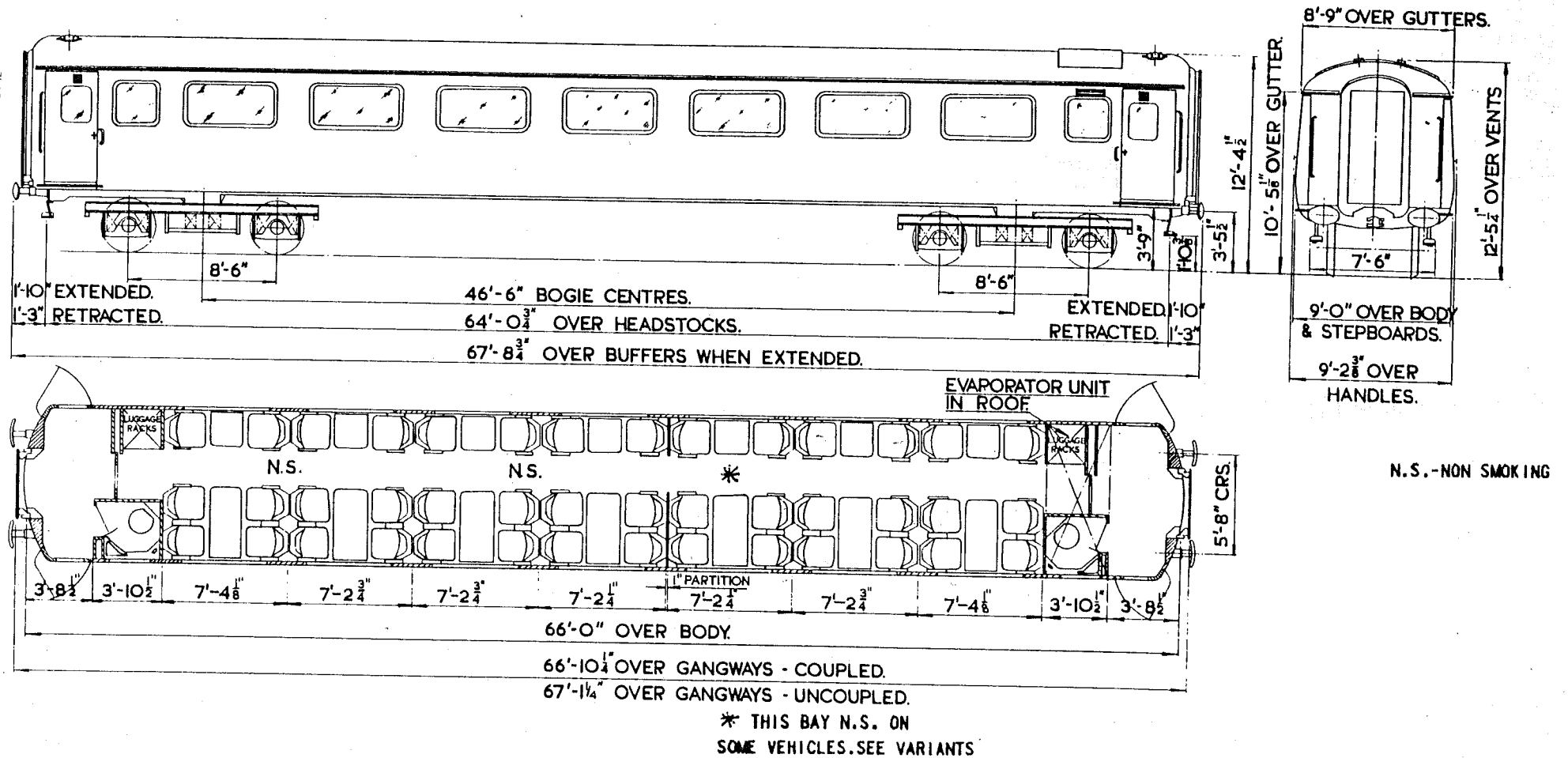

SEATS	42
TOILETS	2
COMPARTMENTS	-
GUARDS COMPARTMENTS	-
VENTILATION	FULL AIR CONDITIONING
CATERING EQUIPMENT	-

ORIGINAL DIAGRAMS FOR REFERENCE:-
BR 83

ISSUE 2 DATE OCT '86

12

AD 107

BRAKES
BOGIE/SUSPENSION
BODY CONSTRUCTION
COUPLINGS
TRAIN HEATING
E.T.H. INDEX
MAX. SPEED M.P.H.
MIN. RAD. CURVE CHAINS
LIGHTING
TARE WEIGHT TONNES
GANGWAYS
TRAIN COMMUNICATION
BUFFERS
SMOKING ACCOMMADATION

BASIC TYPE

AIR
B4
STEEL
AUTOMATIC DROPHEAD(BUCKEYE)
ELECTRIC BR FULL AIR CONDITIONING
5 PLUS 600 AMP WIRING
100
3.5
FLUORESCENT & TUNGSTEN
33.5
PULLMAN
PUBLIC ADDRESS
RETRACTABLE SPINDLE(559X356 OVAL)
50% NON SMOKING

ALTERNATIVES

71% NON SMOKING

TRACTION DATA FOR MULTIPLE UNITS

BASIC TYPE

AD 107 1A

VARIANTS

1B 71% NON SMOKING

FIRST OPEN-MK 111A

CLASS ---

F0

AD 108

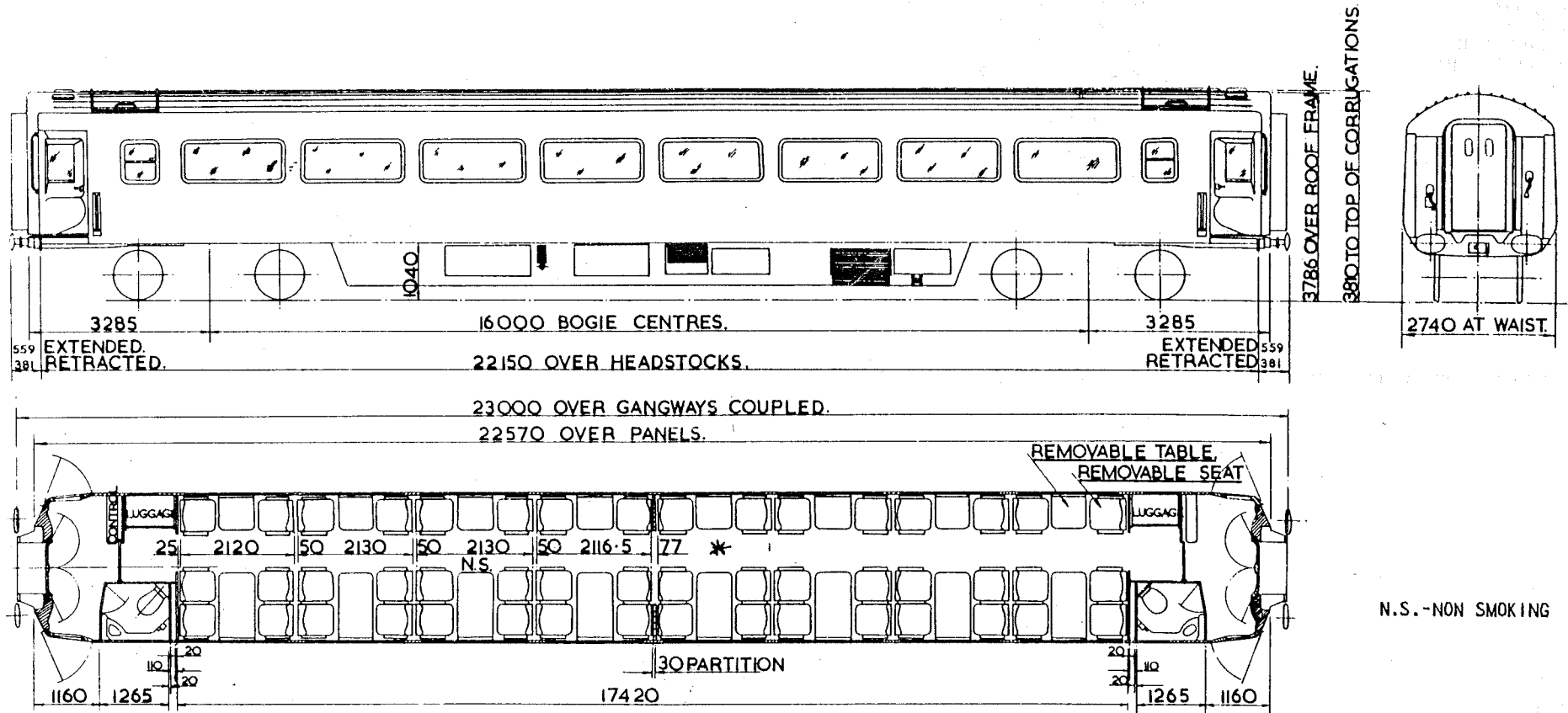

* THIS BAY N.S. ON SOME VEHICLES. SEE VARIANTS

N.S. - NON SMOKING

SEATS	48
TOILETS	2
COMPARTMENTS	-
GUARDS COMPARTMENTS	-
VENTILATION	FULL AIR CONDITIONING
CATERING EQUIPMENT	-

ORIGINAL DIAGRAMS FOR REFERENCE:- BR 69

ISSUE 4 DATE APR 87

AD 108

BASIC TYPE

BRAKES
BOGIE/SUSPENSION
BODY CONSTRUCTION
COUPLINGS
TRAIN HEATING
E.T.H. INDEX
MAX. SPEED M.P.H.
MIN. RAD. CURVE CHAINS
LIGHTING
TARE WEIGHT TONNES
GANGWAYS

AIR
BT 10
STEEL
AUTOMATIC DROPHEAD (BUCKEYE)
ELECTRIC (BR) FULL AIR CONDITIONING
6 PLUS 600 AMP WIRING
125
4.5
FLUORESCENT & TUNGSTEN
33
CENTRALLY SUPPORTED SWIVELLING FOAM DIAPHRAGM STEEL FACE PLATE
PUBLIC ADDRESS
RETRACTABLE SPINDLE (559x356 OVAL)
50% NON SMOKING

ALTERNATIVES

BT 15

4.1

CENTRALLY SUPPORTED SWIVELLING FLEXIBLE DIAPHRAGM
STEEL FACE PLATE

62.5% NON SMOKING

TRACTION DATA FOR MULTIPLE UNITSBASIC TYPE

AD 108 OA

VARIANTS

OB GANGWAY HAS FLEXIBLE DIAPHRAGM.
OC BT 15 BOGIES, MIN. RAD. CURVE 4.1.
OD 62.5% NON SMOKING.
OE 100% NON SMOKING.

FIRST OPEN-MK 111B

CLASS ---

F0

AD 110

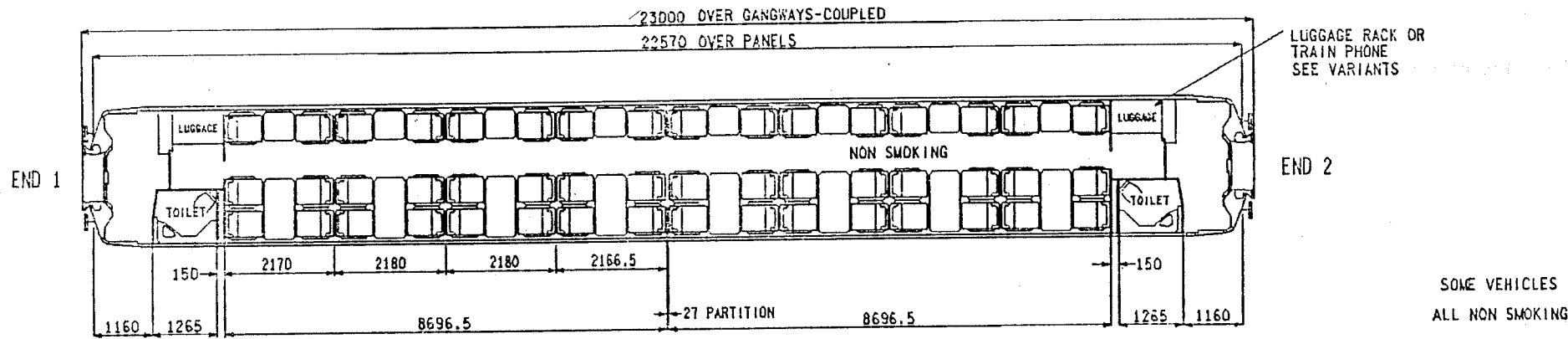
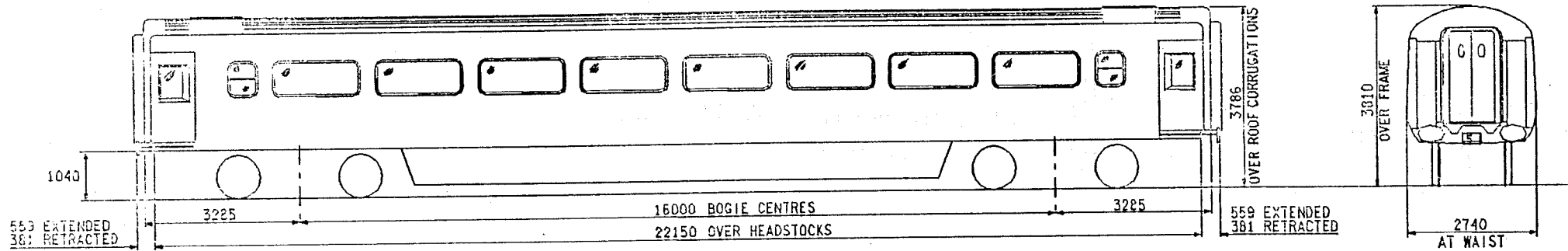

SEATS	48
TOILETS	2
COMPARTMENTS	-
GUARDS COMPARTMENTS	-
VENTILATION	FULL AIR CONDITIONING
CATERING EQUIPMENT	-

ISSUE 3
DATE JAN '88

AD 110

BASIC TYPE

ALTERNATIVES

BRAKES
BOGIE/SUSPENSION
BODY CONSTRUCTION
COUPLINGS
TRAIN HEATING
E.T.H. INDEX
MAX. SPEED M.P.H.
MIN. RAD. CURVE CHAINS
LIGHTING
TARE WEIGHT TONNES
GANGWAYS
TRAIN COMMUNICATION
BUFFERS
SMOKING ACCOMMODATION

AIR
BT10 d
STEEL
AUTOMATIC DROPHEAD(BUCKEYE)
ELECTRIC(BR)FULL AIR CONDITIONING
6 PLUS 600 AMP WIRING
125
4.5
FLUORESCENT & TUNGSTEN
36.5
CENTRALLY SUPPORTED-SWIVELLING-FLEXIBLE DIAPHRAGM-STEEL FACE PLATE
PUBLIC ADDRESS
RETRACTABLE SPINDLE(559X356 OVAL)
50% NON SMOKING

100% NON SMOKING

TRACTION DATA FOR MULTIPLE UNITS

BASIC TYPE

AD 110 0A

VARIANTS

- OB ALL VEHICLE NON SMOKING
- OC TRAIN PHONE
- OD TRAIN PHONE ALL VEHICLE NON SMOKING

SECOND OPEN-MK I

CLASS ---

SO

AD 201

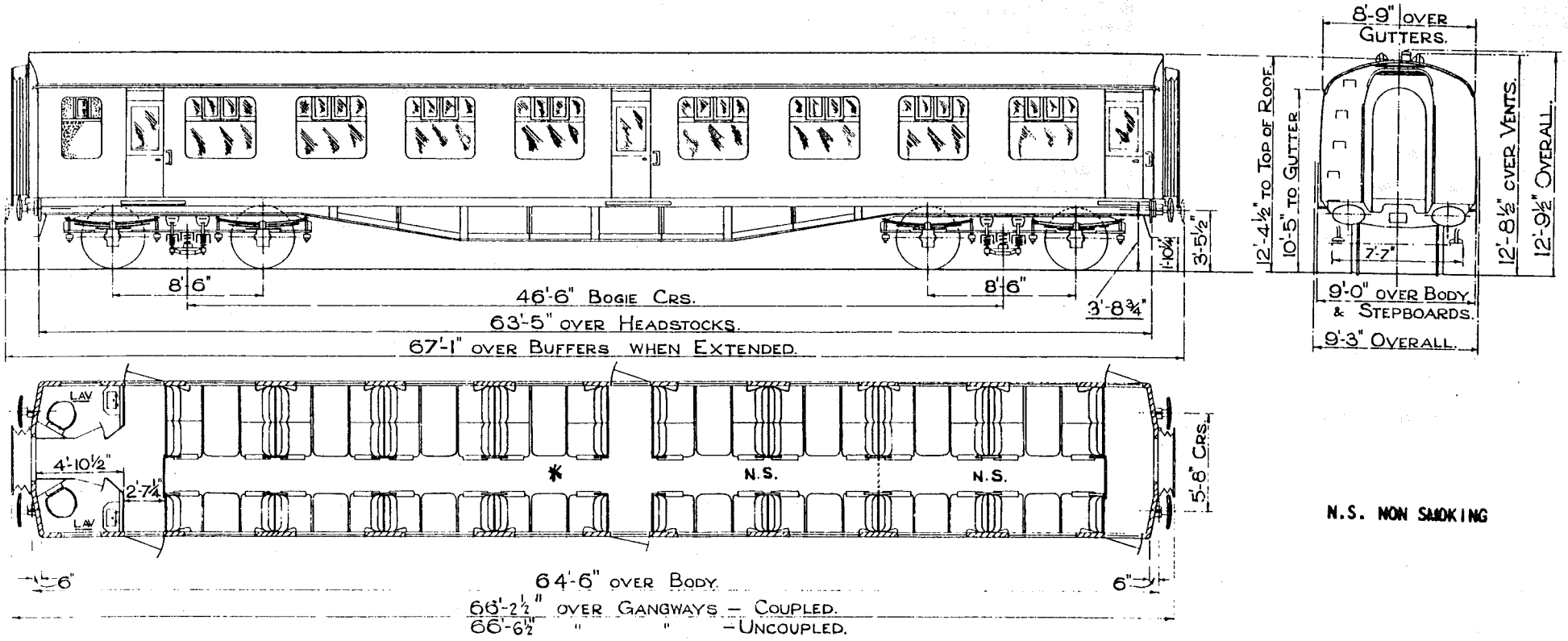

N.S. NON SMOKING

* THIS BAY N.S. ON SOME VEHICLES. SEE VARIANTS

SEATS	48
TOILETS	2
COMPARTMENTS	-
GUARDS COMPARTMENTS	-
VENTILATION	-
CATERING EQUIPMENT	-

ORIGINAL DIAGRAMS FOR REFERENCE - BR 94

ISSUE 2 DATE OCT '86

AD 201

BRAKES
 BOGIE/SUSPENSION
 BODY CONSTRUCTION
 COUPLINGS
 TRAIN HEATING
 E.T.H. INDEX
 MAX. SPEED M.P.H.
 MIN. RAD. CURVE CHAINS
 LIGHTING
 TARE WEIGHT TONNES
 GANGWAYS
 TRAIN COMMUNICATION
 BUFFERS
 SMOKING ACCOMMODATION

BASIC TYPE

VACUUM
 BR MK 1 LIGHT DOUBLE BOLSTER
 STEEL
 AUTOMATIC DROPHEAD (BUCKEYE)
 DUAL (STEAM/ELECTRIC (BR))
 4
 90
 3.5
 TUNGSTEN
 33
 PULLMAN
 NOT FITTED
 RETRACTABLE SPINDLE (559X356 OVAL)
 50% NON SMOKING

ALTERNATIVES

B4

100

62% NON SMOKING

TRACTION DATA FOR MULTIPLE UNITS

BASIC TYPE

AD 201 1A

VARIANTS

- 1B B4 BOGIES, MAX. SPEED 100.
- 1C B4 BOGIES, MAX. SPEED 100, 62% NON SMOKING

SECOND OPEN-MK II

CLASS ---

SO

AD 203

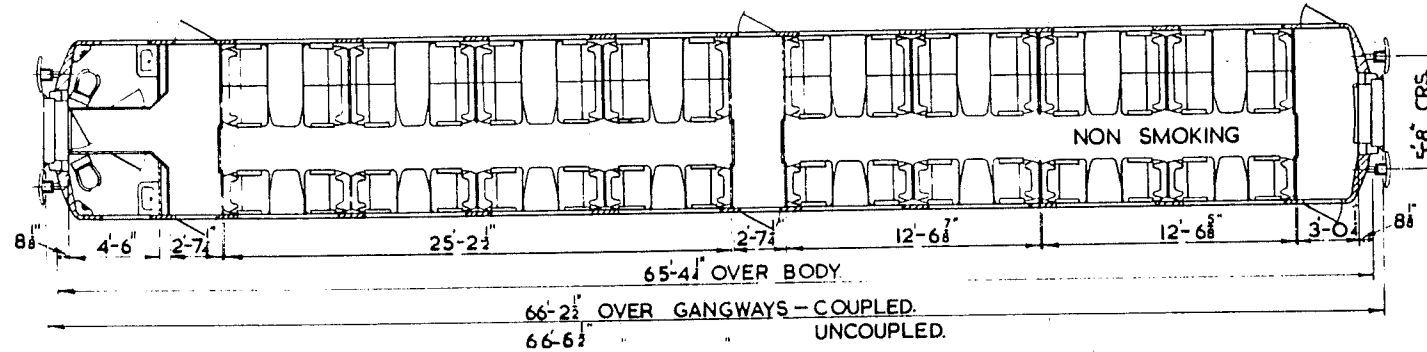
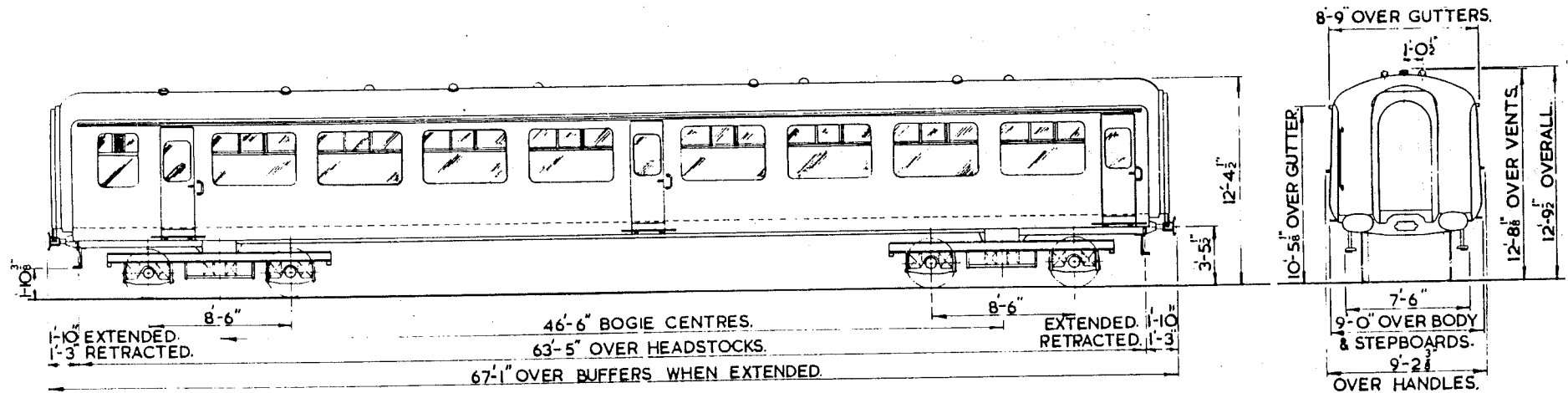

SEATS	48
TOILETS	2
COMPARTMENTS	-
GUARDS COMPARTMENTS	-
VENTILATION	PRESSURE
CATERING EQUIPMENT	-

ORIGINAL DIAGRAMS FOR REFERENCE.-
BR 87

ISSUE DATE
1 SEP' 80

AD 203

BRAKES
BOGIE/SUSPENSION
BODY CONSTRUCTION
COUPLINGS
TRAIN HEATING
E.T.H. INDEX
MAX. SPEED M.P.H.
MIN. RAD. CURVE CHAINS
LIGHTING
TARE VEIGHT TONNES
GANGWAYS
TRAIN COMMUNICATION
BUFFERS

BASIC TYPE

VACUUM
B4
STEEL
AUTOMATIC DROPHEAD (BUCKEYE)
DUAL (STEAM/ELECTRIC (BR)) WITH PRESSURE VENTILATION & HEATING
4
100
3.5
FLUORESCENT & TUNGSTEN
32.5
PULLMAN
NOT FITTED
RETRACTABLE SPINDLE (559X356 OVAL)

ALTERNATIVES

AIR

PUBLIC ADDRESS

TRACTION DATA FOR MULTIPLE UNITS

BASIC TYPE

AD 203 OA

VARIANTS

08 AIR BRAKES.
18 AIR BRAKES, PUBLIC ADDRESS.

SECOND OPEN-MK I

CLASS ----

SO

AD 204

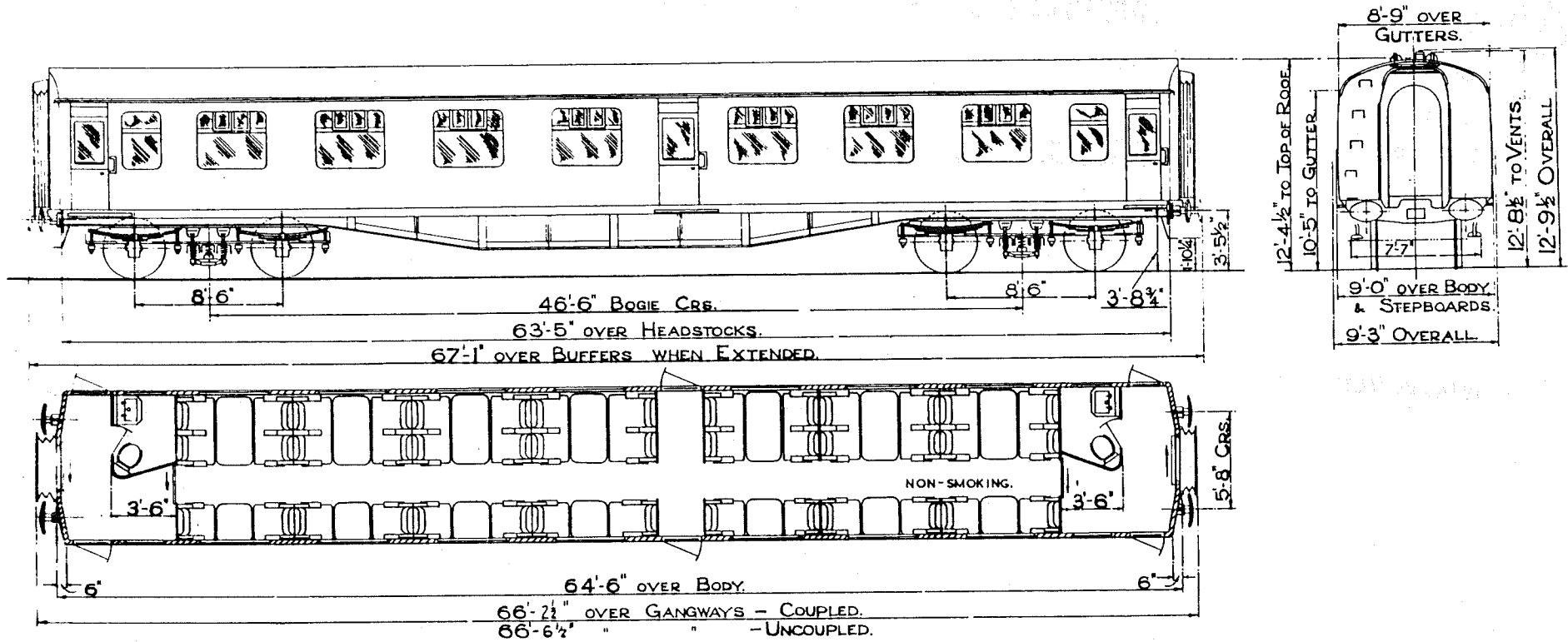

SEATS	42
TOILETS	2
COMPARTMENTS	-
GUARDS COMPARTMENTS	-
VENTILATION	-
CATERING EQUIPMENT	-

ORIGINAL DIAGRAMS FOR REFERENCE.-
BR 73

ISSUE 2 DATE MAY '81

AD 204

BRAKES
BOGIE/SUSPENSION
BODY CONSTRUCTION
COUPLINGS
TRAIN HEATING
E.T.H. INDEX
MAX. SPEED M.P.H.
MIN. RAD. CURVE CHAINS
LIGHTING
TARE VEIGHT TONNES
GANGWAYS
TRAIN COMMUNICATION
BUFFERS

BASIC TYPE

AIR
COMMONWEALTH
STEEL
AUTOMATIC DROPHEAD (BUCKEYE)
DUAL (STEAM/ELECTRIC (BR))
3
100
3.5
FLUORESCENT & TUNGSTEN
33.5
PULLMAN
NOT FITTED
RETRACTABLE SPINDLE (559X356 OVAL)

ALTERNATIVES

B4

TUNGSTEN
35
PUBLIC ADDRESS

TRACTION DATA FOR MULTIPLE UNITS

BASIC TYPE

AD 204 1B

VARIANTS

1D TARE 35.
2C B4 BOGIES, TUNGSTEN LIGHTING.
2D TARE 35, PUBLIC ADDRESS FITTED.

SECOND OPEN-MK 11C

CLASS ---

SO

AD 205

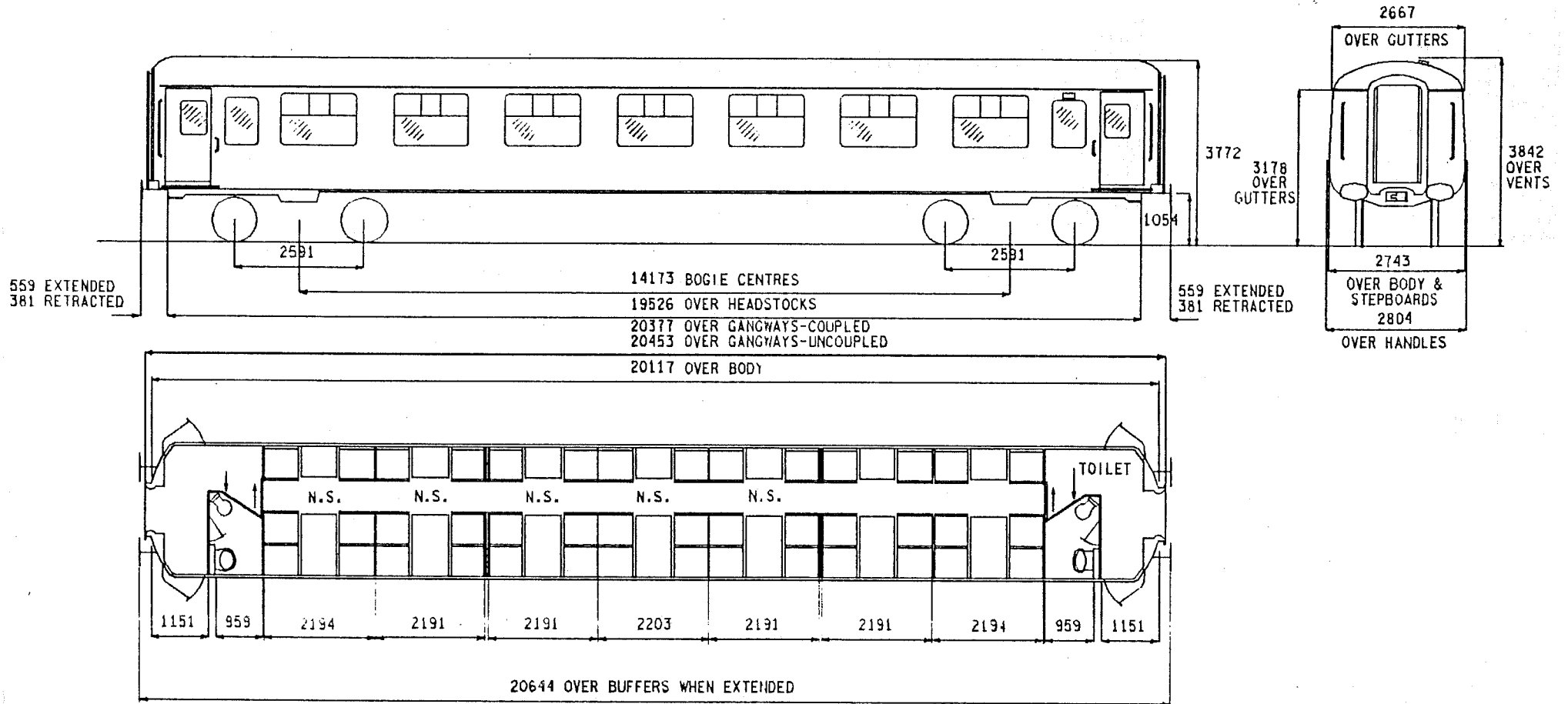

SEATS	42
TOILETS	2
COMPARTMENTS	-
GUARDS COMPARTMENTS	-
VENTILATION	PRESSURE
CATERING EQUIPMENT	-

ISSUE 2
DATE APR '83

AD 205

BASIC TYPE

ALTERNATIVES

BRAKES
BOGIE/SUSPENSION
BODY CONSTRUCTION
COUPLINGS
TRAIN HEATING
E.T.H. INDEX
MAX. SPEED M.P.H.
MIN. RAD. CURVE CHAINS
LIGHTING
TARE WEIGHT TONNES
GANGWAYS
TRAIN COMMUNICATION
BUFFERS
BRAKE BLOCKS

AIR
B4
STEEL
AUTOMATIC DROPHEAD(BUCKEYE)
DUAL(STEAM/ELECTRIC(BR))WITH PRESSURE VENTILATION & HEATING
4
100
3.5
FLUORESCENT & TUNGSTEN
33
PULLMAN
PUBLIC ADDRESS
RETRACTABLE SPINDLE(559 X 356 OVAL)
CAST IRON

NOT FITTED
COMPOSITION

TRACTION DATA FOR MULTIPLE UNITS

BASIC TYPE

AD 205 OA

VARIANTS

0B COMPOSITION BRAKE BLOCKS
1A TRAIN COMMUNICATION NOT FITTED.
1B TRAIN COMMUNICATION NOT FITTED, COMPOSITION BRAKE BLOCKS

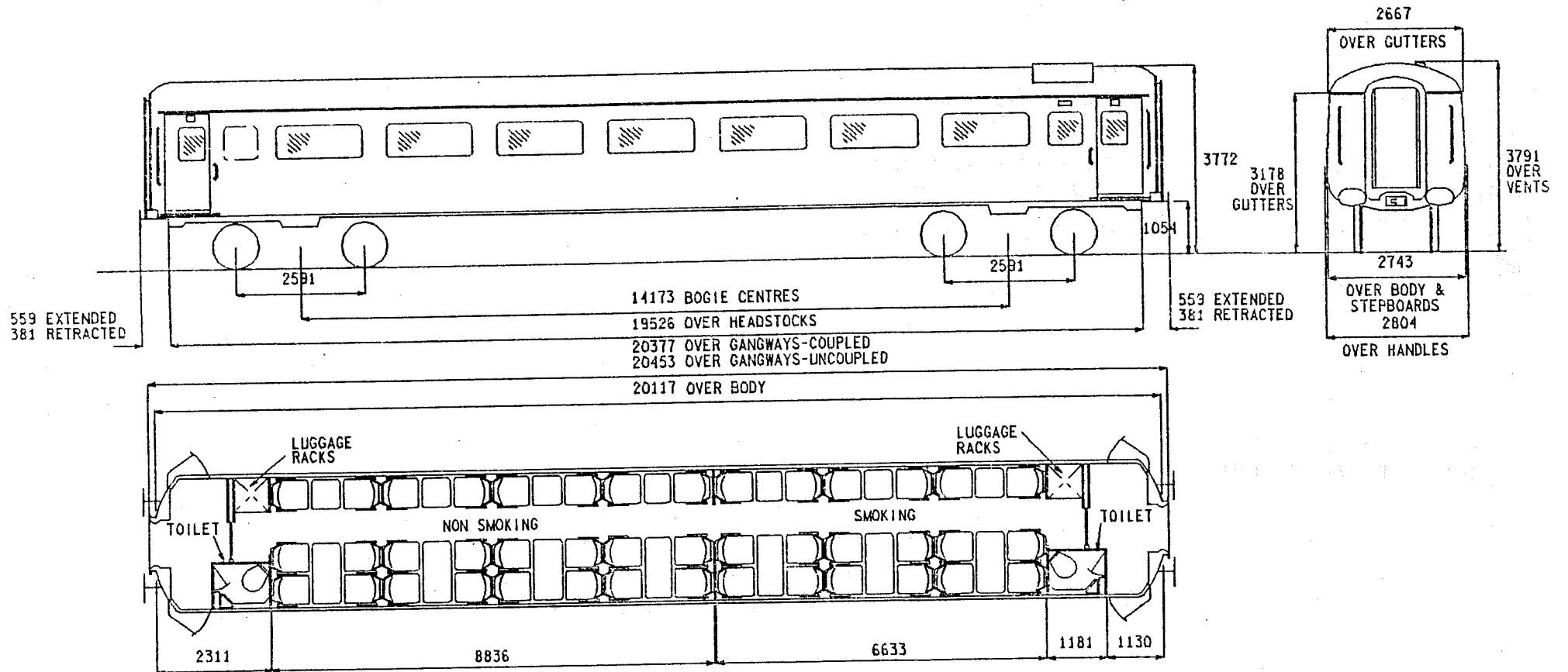

SEATS 42
TOILETS 2
COMPARTMENTS -
GUARDS COMPARTMENTS -
VENTILATION FULL AIR CONDITIONING
CATERING EQUIPMENT -

ORIGINAL DIAGRAMS FOR REFERENCE:-
BR 83

ISSUE 2
DATE JUL 87

AD 206

BASIC TYPE

ALTERNATIVES

BRAKES
BOGIE/SUSPENSION
BODY CONSTRUCTION
COUPLINGS
TRAIN HEATING
E.T.H. INDEX
MAX. SPEED M.P.H.
MIN. RAD. CURVE CHAINS
LIGHTING
TARE WEIGHT TONNES
GANGWAYS
TRAIN COMMUNICATION
BUFFERS

AIR
B4
STEEL
AUTOMATIC DROPHEAD (BUCKEYE)
ELECTRIC (BR) FULL AIR CONDITIONING
5 PLUS 600 AMP WIRING
100
3.5
FLUORESCENT & TUNGSTEN
33.5
PULLMAN
PUBLIC ADDRESS
RETRACTABLE SPINDLE (559X356 OVAL)

TRACTION DATA FOR MULTIPLE UNITS

BASIC TYPE

AD 206 OA

VARIANTS

NONE

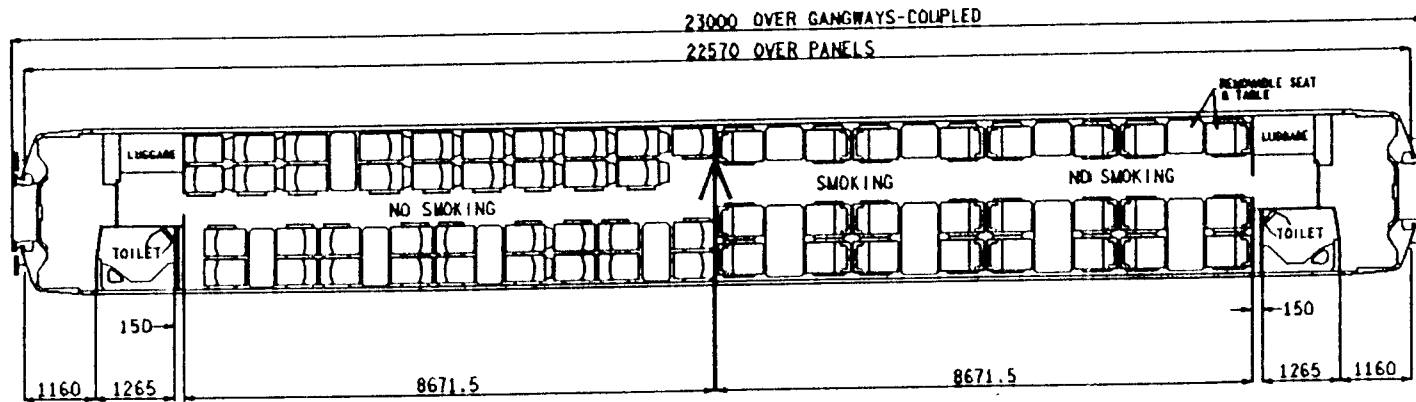
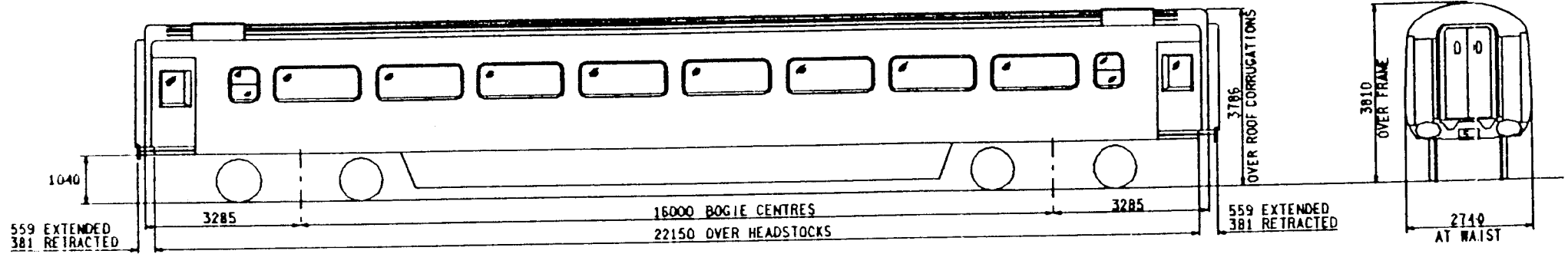

SEATS 24(FIRST) 37(SECOND)
 TOILETS 2
 COMPARTMENTS -
 GUARDS COMPARTMENTS -
 VENTILATION FULL AIR CONDITIONING
 CATERING EQUIPMENT -

ISSUE 1 DATE JUN 86

AD 301

BRAKES
BOGIE/SUSPENSION
BODY CONSTRUCTION
COUPLINGS
TRAIN HEATING
E.T.H. INDEX
MAX. SPEED M.P.H.
MIN. RAD. CURVE CHAINS
LIGHTING
TARE WEIGHT TONNES
GANGWAYS
TRAIN COMMUNICATION
BUFFERS

BASIC TYPE

AIR
BT10 d
STEEL
AUTOMATIC DROPHEAD (BUCKEYE)
ELECTRIC (BR) FULL AIR CONDITIONING
6 PLUS 600 AMP WIRING
125
4.5
FLUORESCENT & TUNGSTEN
34.6 (ESTIMATED)
CENTRALLY SUPPORTED-SWIVELLING-FLEXIBLE DIAPHRAGM-STEEL FACE PLATE
PUBLIC ADDRESS
RETRACTABLE SPINDLE (559X356 OVAL)

ALTERNATIVES

TRACTION DATA FOR MULTIPLE UNITS

BASIC TYPE
AD 301 OA

VARIANTS
NONE

FIRST OPEN-MK 111B

CLASS ---

BFO

AE 101

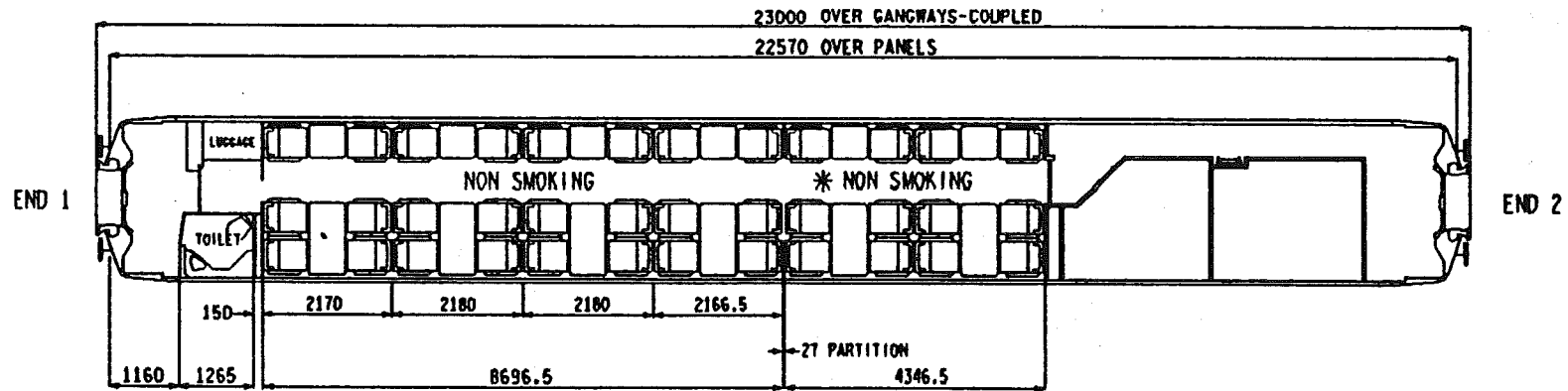
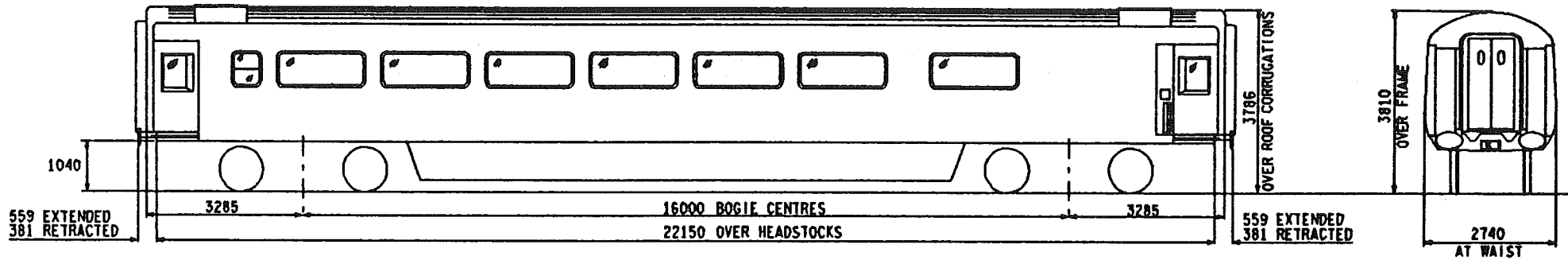

* THIS BAY SMOKING ON SOME VEHICLES

- SEATS 36
- TOILETS 1
- COMPARTMENTS -
- GUARDS COMPARTMENTS -
- VENTILATION FULL AIR CONDITIONING
- CATERING EQUIPMENT -

ISSUE 3 DATE APR 89

AE 101

BRAKES
 BOGIE/SUSPENSION
 BODY CONSTRUCTION
 COUPLINGS
 TRAIN HEATING
 E.T.H. INDEX
 MAX. SPEED M.P.H.
 MIN. RAD. CURVE CHAINS
 LIGHTING
 TARE WEIGHT TONNES
 GANGWAYS
 TRAIN COMMUNICATION
 BUFFERS
 SMOKING ACCOMMODATION

BASIC TYPE

AIR
 BT10 e
 STEEL
 AUTOMATIC DROPHEAD(BUCKEYE)
 ELECTRIC(BR)FULL AIR CONDITIONING
 6 PLUS 600 AMP WIRING
 125
 4.5
 FLUORESCENT & TUNGSTEN
 34(ESTIMATED)
 CENTRALLY SUPPORTED-SWIVELLING-FLEXIBLE DIAPHRAGM-STEEL FACE PLATE
 PUBLIC ADDRESS
 RETRACTABLE SPINDLE(559X356 OVAL)
 100% NO SMOKING

ALTERNATIVES

66% NO SMOKING

TRACTION DATA FOR MULTIPLE UNITS

MODIFIED FROM FIRST OPEN-MARCH 85

BASIC TYPE

AE 101 OA

VARIANTS

OB 66% NO SMOKING

BRAKE SECOND OPEN-MK I

CLASS ---

BS0

AE 201

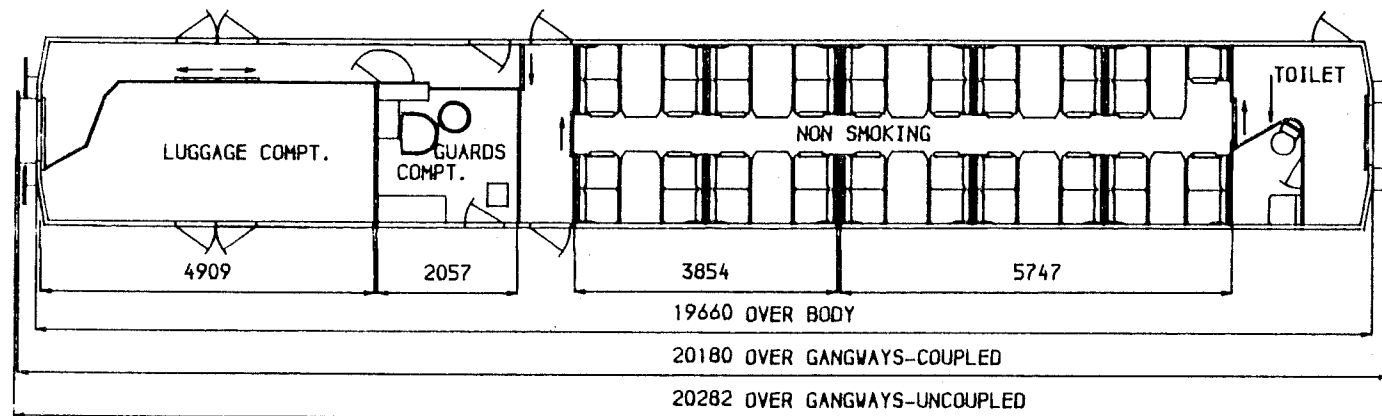
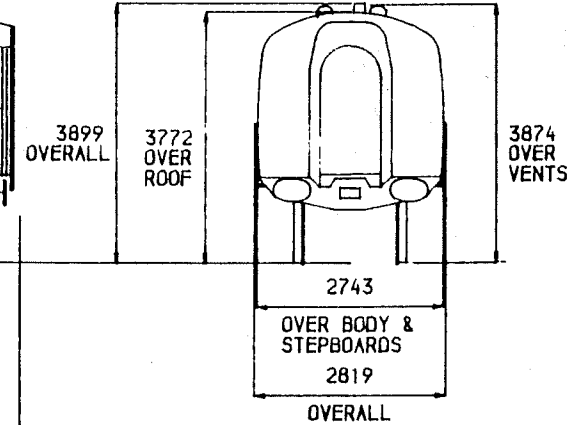
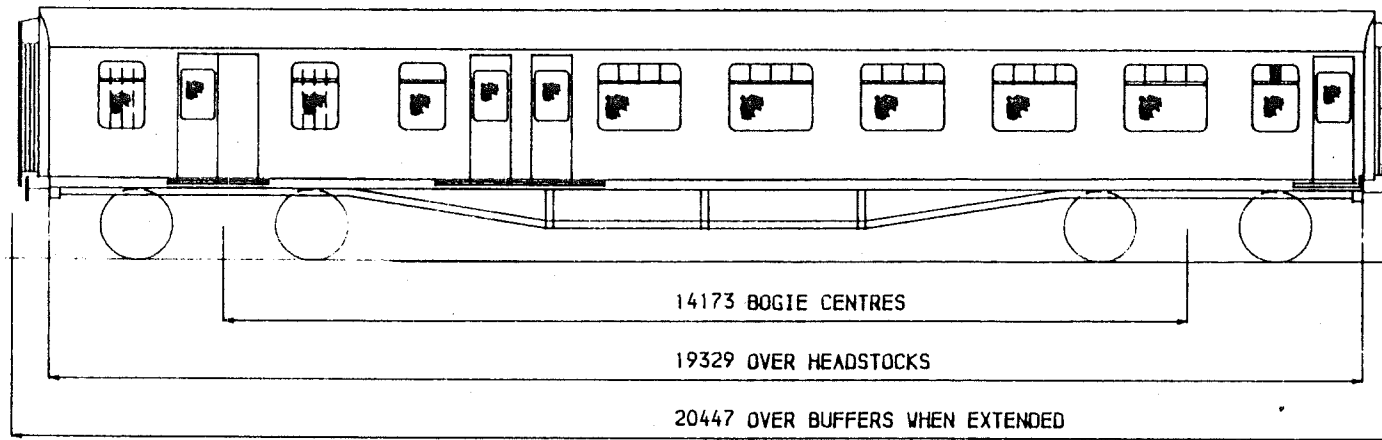

SEATS	39
TOILETS	1
COMPARTMENTS	-
GUARDS COMPARTMENTS	1
VENTILATION	-
CATERING EQUIPMENT	-

ORIGINAL DIAGRAMS FOR REFERENCE.-
BR 183

ISSUE 2 DATE MAY 81

AE 201

BRAKES
BOGIE/SUSPENSION
BODY CONSTRUCTION
COUPLINGS
TRAIN HEATING
E.T.H. INDEX
MAX. SPEED M.P.H.
MIN. RAD. CURVE CHAINS
LIGHTING
TARE WEIGHT TONNES
GANGWAYS
TRAIN COMMUNICATION
BUFFERS

BASIC TYPE

VACUUM
B4
STEEL
AUTOMATIC DROPHEAD (BUCKEYE)
STEAM
-
100
3.5
TUNGSTEN
33.5
PULLMAN
NOT FITTED
RETRACTABLE SPINDLE (559X356 OVAL)

ALTERNATIVES

VACUUM & AIR
BR MKI LIGHT DOUBLE BOLSTER

DUAL (STEAM/ELECTRIC (BR))
3
90

TRACTION DATA FOR MULTIPLE UNITS

BASIC TYPE

AE 201 OA

VARIANTS

0B BR MK I LIGHT DOUBLE BOLSTER BOGIES, MAX. SPEED 90.
1C BR MK I LIGHT DOUBLE BOLSTER BOGIES, MAX. SPEED 90, DUAL HEATING (STEAM/ELECTRIC (BR)), VACUUM & AIR BRAKES, E.T.H. 3

BRAKE SECOND OPEN-MK I

CLASS ---

BSO

AE 202

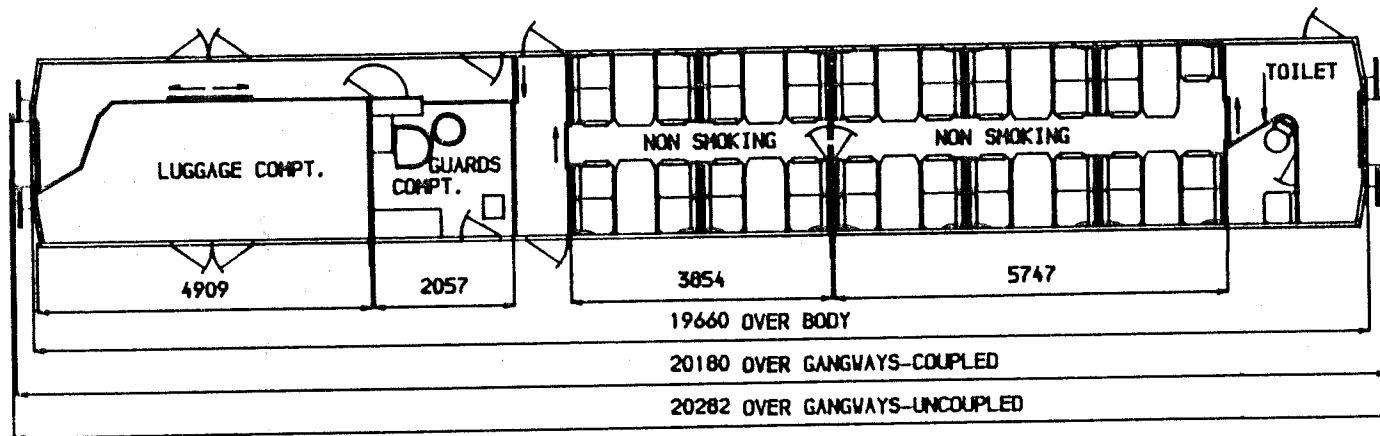
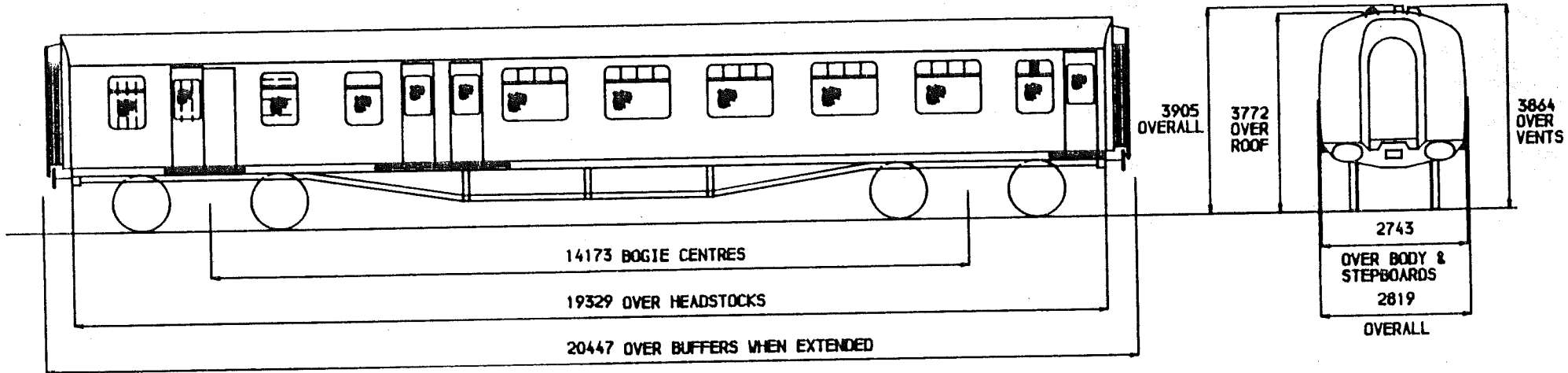

SEATS	39
TOILETS	1
COMPARTMENTS	-
GUARDS COMPARTMENTS	1
VENTILATION	-
CATERING EQUIPMENT	-

ORIGINAL DIAGRAMS FOR REFERENCE.-
BR 184

ISSUE 1 DATE SEP '80

AE 202

BRAKES
BOGIE/SUSPENSION
BODY CONSTRUCTION
COUPLINGS
TRAIN HEATING
E. T. H. INDEX
MAX. SPEED M. P. H.
MIN. RAD. CURVE CHAINS
LIGHTING
TARE VEIGHT TONNES
GANGWAYS
TRAIN COMMUNICATION
BUFFERS

BASIC TYPE

VACUUM
COMMONWEALTH
STEEL
AUTOMATIC DROPHEAD (BUCKEYE)
STEAM
-
100
3.5
FLUORESCENT & TUNGSTEN
36
PULLMAN
NOT FITTED
RETRACTABLE SPINDLE (559X356 OVAL)

ALTERNATIVES

TRACTION DATA FOR MULTIPLE UNITS

BASIC TYPE

AE 202 08

VARIANTS

NONE

BRAKE STANDARD OPEN-MK II

CLASS ---

BSO

AE 203

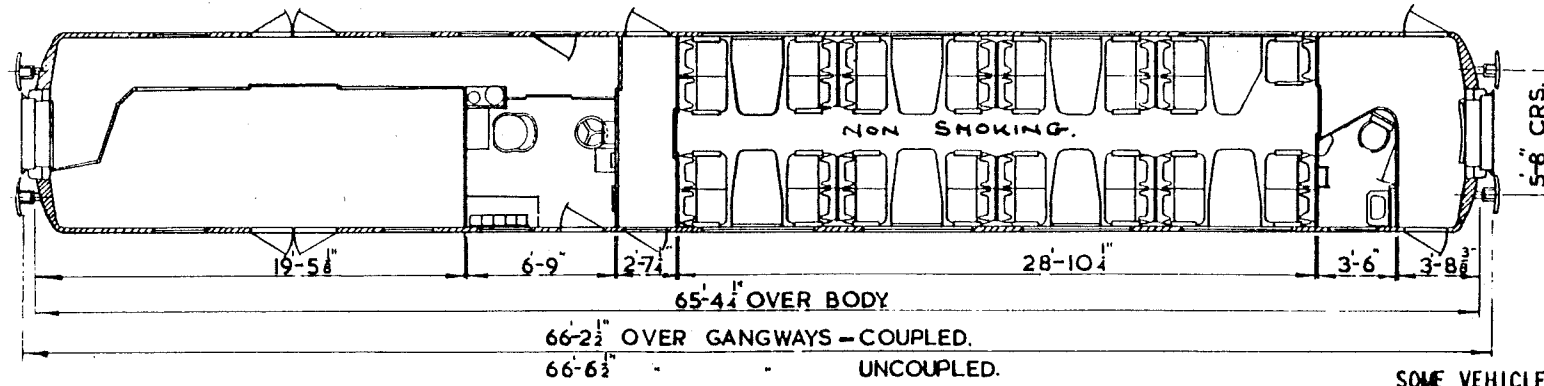
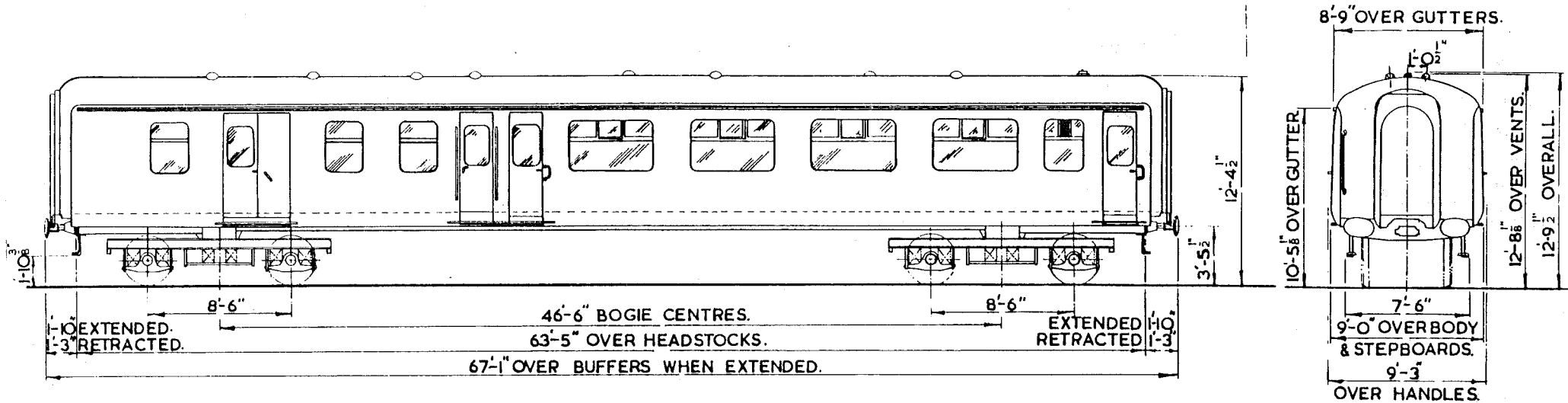

SOME VEHICLES HAVE ALL SALOON SMOKING

SEATS	31
TOILETS	1
COMPARTMENTS	-
GUARDS COMPARTMENTS	1
VENTILATION	PRESSURE
CATERING EQUIPMENT	-

ORIGINAL DIAGRAMS FOR REFERENCE:-
BR 185

ISSUE 5 DATE APR 88

AE 203

BRAKES
 BOGIE/SUSPENSION
 BODY CONSTRUCTION
 COUPLINGS
 TRAIN HEATING
 E.T.H. INDEX
 MAX.SPEED M.P.H.
 MIN.RAD.CURVE CHAINS
 LIGHTING
 TARE WEIGHT TONNES
 GANGWAYS
 TRAIN COMMUNICATION
 BUFFERS

BASIC TYPE

VACUUM
 B4
 STEEL
 AUTOMATIC DROPHEAD(BUCKEYE)
 DUAL(STEAM/ELECTRIC(BR))WITH PRESSURE VENTILATION & HEATING
 4
 100
 3.5
 FLUORESCENT & TUNGSTEN
 32
 PULLMAN
 NOT FITTED
 RETRACTABLE SPINDLE(559X356 OVAL)

ALTERNATIVES

AIR

PUBLIC ADDRESS,P.A.& TRANSMITTER,DRIVER GUARD

TRACTION DATA FOR MULTIPLE UNITSBASIC TYPE

AE 203 OA

VARIANTS

- 0B AIR BRAKES.
- 1A DRIVER GUARD COMMUNICATION FITTED.
- 1B AIR BRAKES,DRIVER GUARD COMMUNICATION FITTED.
- 1C ALL SALOON SMOKING,DRIVER GUARD COMMUNICATION FITTED.
- 2C ALL SALOON SMOKING,PUBLIC ADDRESS FITTED.
- 3A PUBLIC ADDRESS & TRANSMITTER FITTED.
- 3B AIR BRAKES,PUBLIC ADDRESS & TRANSMITTER FITTED.
- 3C ALL SALOON SMOKING,PUBLIC ADDRESS & TRANSMITTER FITTED.

BRAKE STANDARD OPEN-MK 11A

CLASS ---

BSO

AE 204

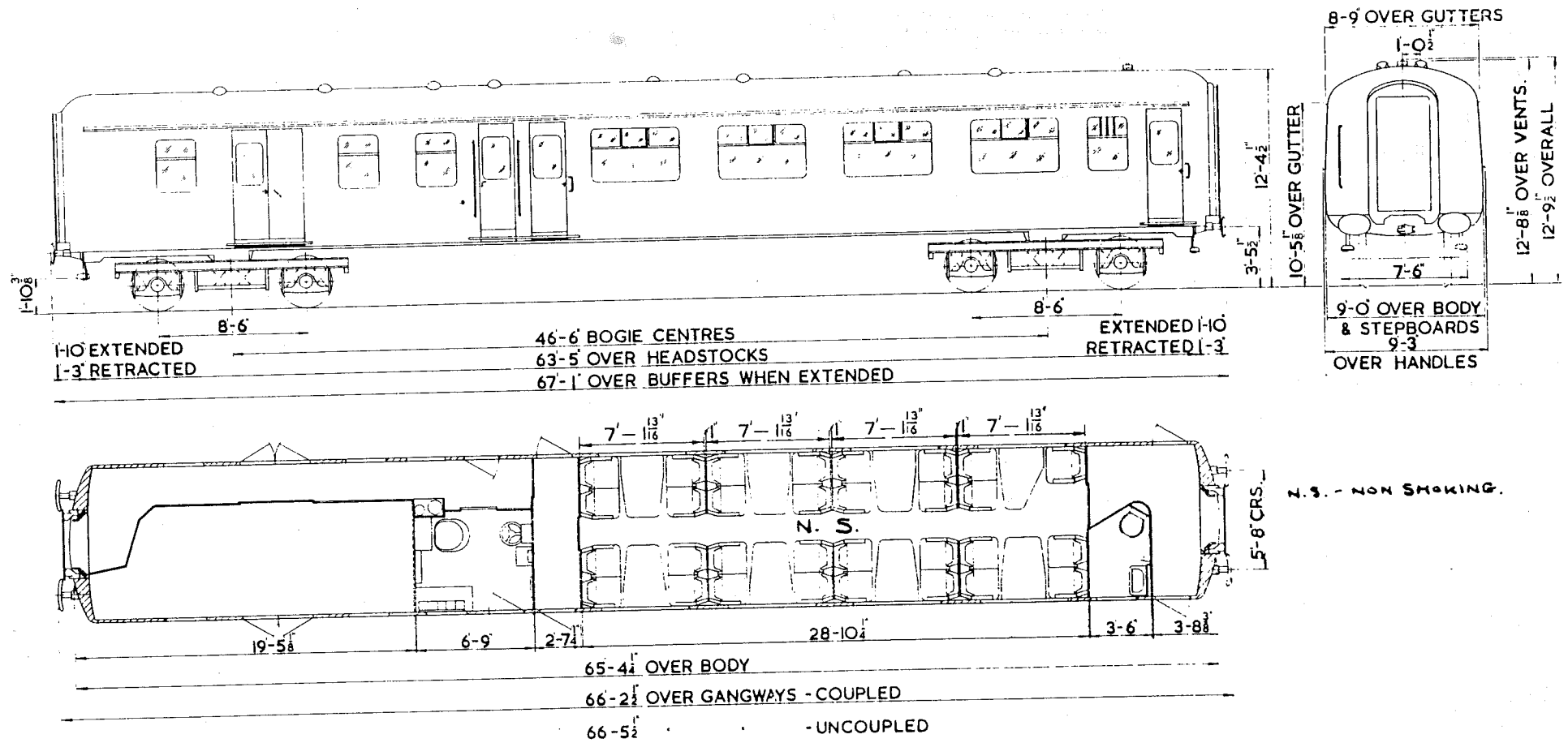

SEATS	31
TOILETS	1
COMPARTMENTS	-
GUARDS COMPARTMENTS	1
VENTILATION	PRESSURE
CATERING EQUIPMENT	-

ORIGINAL DIAGRAMS FOR REFERENCE:-
BR 180

ISSUE 2 DATE APR 88

AE 204

BRAKES
 BOGIE/SUSPENSION
 BODY CONSTRUCTION
 COUPLINGS
 TRAIN HEATING
 E.T.H. INDEX
 MAX.SPEED M.P.H.
 MIN.RAD.CURVE CHAINS
 LIGHTING
 TARE WEIGHT TONNES
 GANGWAYS
 TRAIN COMMUNICATION
 BUFFERS

BASIC TYPE

AIR
 B4
 STEEL
 AUTOMATIC DROPHEAD(BUCKEYE)
 DUAL(STEAM/ELECTRIC(BR)) WITH PRESSURE VENTILATION & HEATING
 4
 100
 3.5
 FLUORESCENT & TUNGSTEN
 32
 PULLMAN
 NOT FITTED
 RETRACTABLE SPINDLE(559X356 OVAL)

ALTERNATIVES

P.A.& TRANSMITTER FITTED

TRACTION DATA FOR MULTIPLE UNITS

BASIC TYPE

AE 204 0A

VARIANTS

1A PUBLIC ADDRESS & TRANSMITTER FITTED.

BRAKE SECOND OPEN-MK 11C

CLASS ---

BS0

AE 205

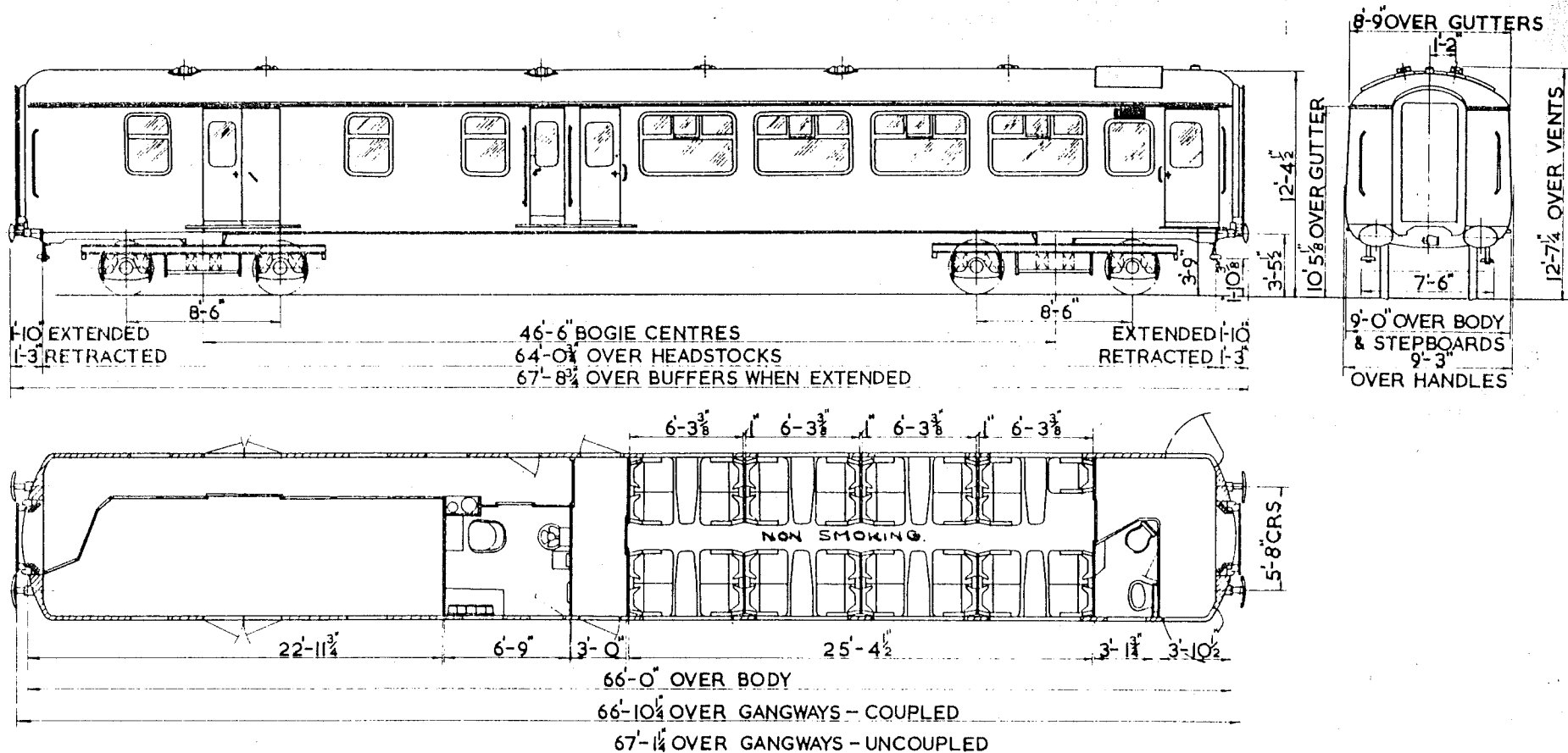

SEATS	31
TOILETS	1
COMPARTMENTS	-
GUARDS COMPARTMENTS	1
VENTILATION	PRESSURE
CATERING EQUIPMENT	-

ORIGINAL DIAGRAMS FOR REFERENCE:-
BR 186

ISSUE 2 DATE DEC 86

AE 205

BASIC TYPE

ALTERNATIVES

BRAKES
BOGIE/SUSPENSION
BODY CONSTRUCTION
COUPLINGS
TRAIN HEATING
E.T.H. INDEX
MAX.SPEED M.P.H.
MIN.RAD.CURVE CHAINS
LIGHTING
TARE WEIGHT TONNES
GANGWAYS
TRAIN COMMUNICATION
BUFFERS

AIR
B4
STEEL
AUTOMATIC DROPHEAD(BUCKEYE)
DUAL(STEAM/ELECTRIC(BR))WITH PRESSURE VENTILATION & HEATING
4
100
3.5
FLUORESCENT & TUNGSTEN
32.5
PULLMAN
NOT FITTED
RETRACTABLE SPINDLE(559X356 OVAL)

PUBLIC ADDRESS WITH TRANSMITTER

TRACTION DATA FOR MULTIPLE UNITS

BASIC TYPE

AE 205 OA

VARIANTS

1A PUBLIC ADDRESS WITH TRANSMITTER FITTED
OB ALL SMOKING.

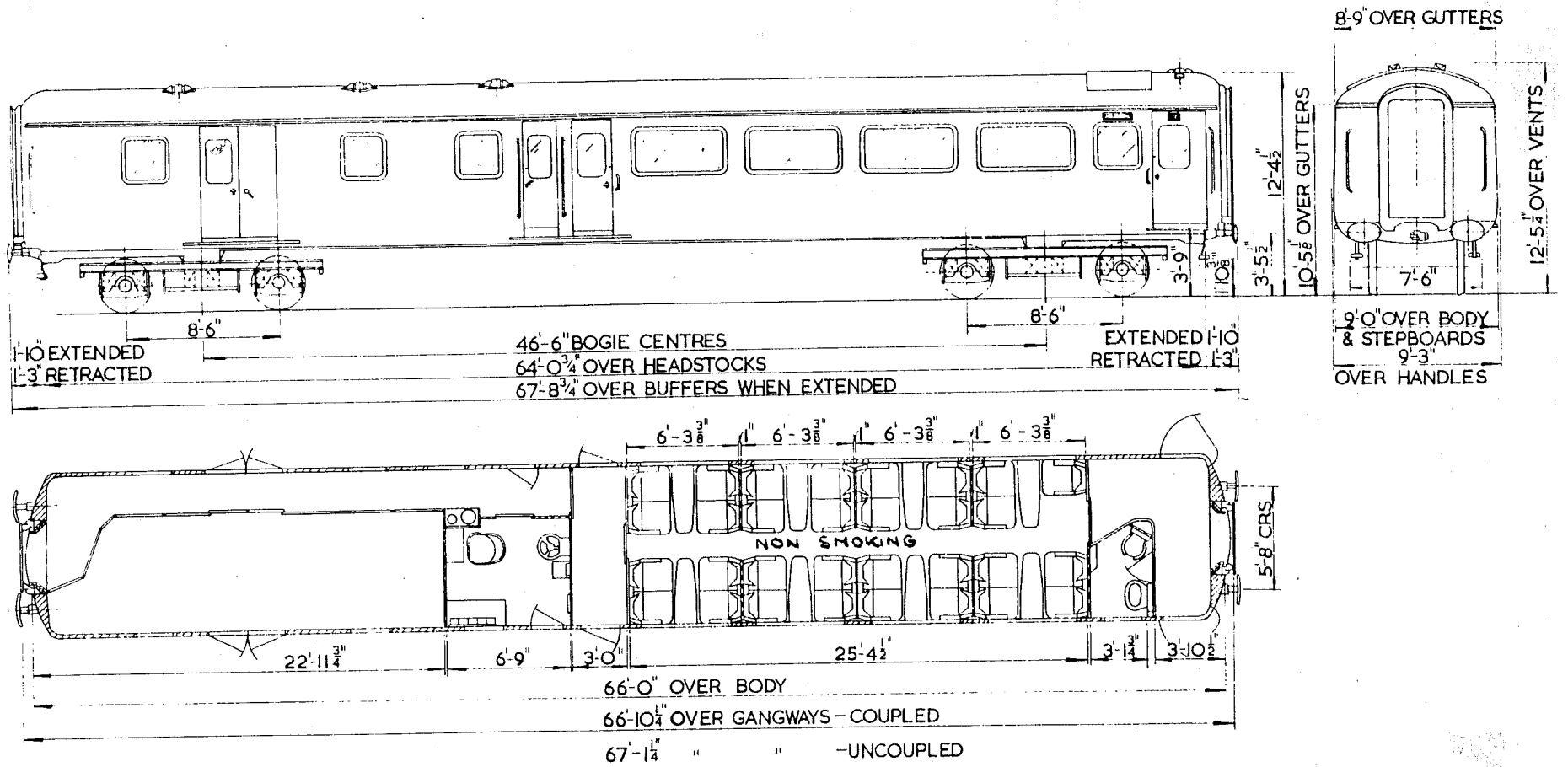

- SEATS 31
- TOILETS 1
- COMPARTMENTS -
- GUARDS COMPARTMENTS 1
- VENTILATION FULL AIR CONDITIONING
- CATERING EQUIPMENT -

ORIGINAL DIAGRAMS FOR REFERENCE:-
BR 187

ISSUE 3 DATE MAR 87

AE 206

BRAKES
 BOGIE/SUSPENSION
 BODY CONSTRUCTION
 COUPLINGS
 TRAIN HEATING
 E.T.H. INDEX
 MAX. SPEED M.P.H.
 MIN. RAD. CURVE CHAINS
 LIGHTING
 TARE WEIGHT TONNES
 GANGWAYS
 TRAIN COMMUNICATION
 BUFFERS

BASIC TYPE

AIR
 B4
 STEEL
 AUTOMATIC DROPHEAD(BUCKEYE)
 ELECTRIC(BR)FULL AIR CONDITIONING
 5
 100
 3.5
 FLUORESCENT & TUNGSTEN
 34
 PULLMAN
 PUBLIC ADDRESS & TRANSMITTER
 RETRACTABLE SPINDLE(559X356 OVAL)

ALTERNATIVES

PUBLIC ADDRESS , TRANSMITTER & DRIVER GUARD

TRACTION DATA FOR MULTIPLE UNITS

BASIC TYPE

AE 206 DA

VARIANTS

- 1A PUBLIC ADDRESS, TRANSMITTER & DRIVER GUARD COMMUNICATION FITTED
- 0B ALL SMOKING.
- 1B PUBLIC ADDRESS, TRANSMITTER & DRIVER GUARD COMMUNICATION FITTED, ALL SMOKING.

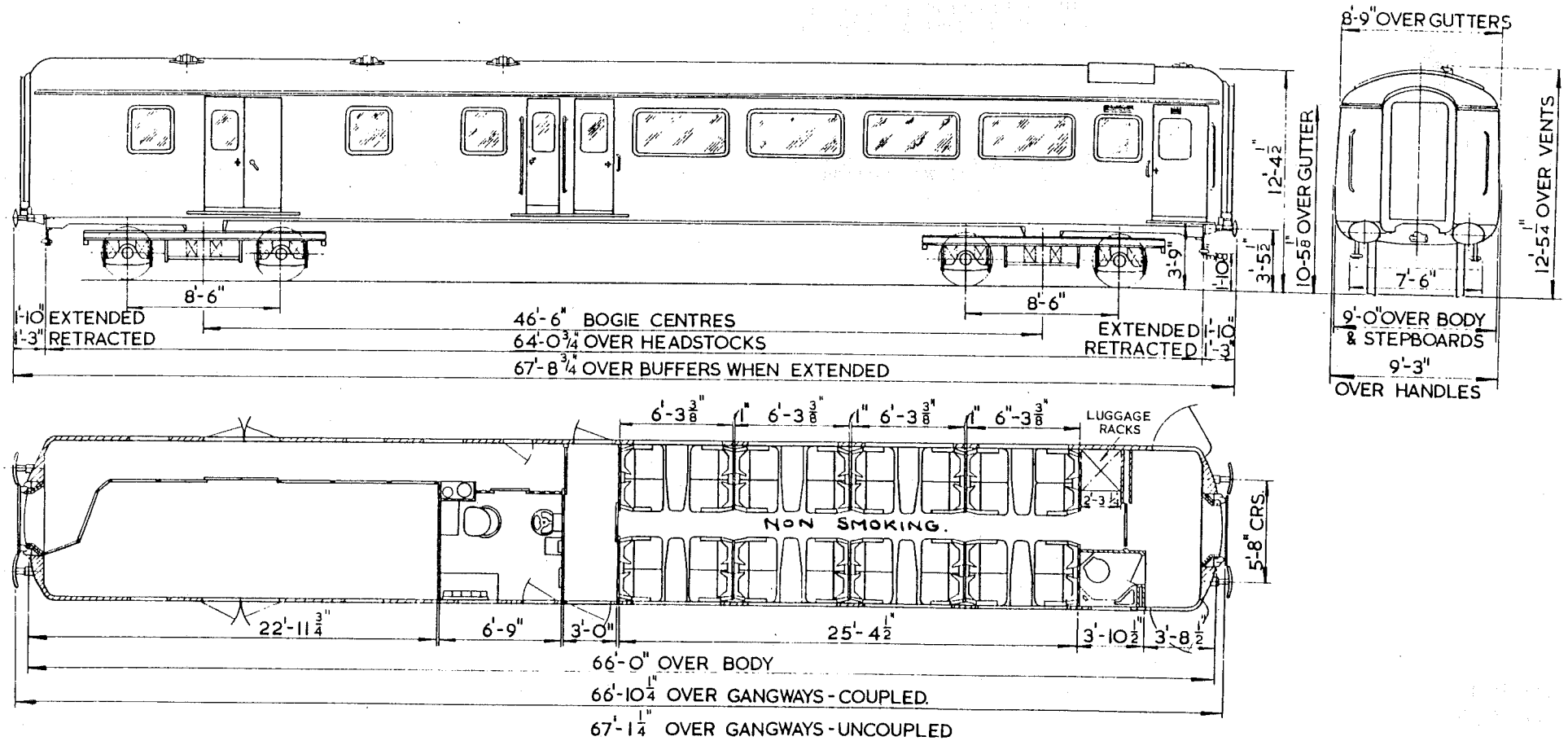

SEATS	32
TOILETS	1
COMPARTMENTS	-
GUARDS COMPARTMENTS	1
VENTILATION	FULL AIR CONDITIONING
CATERING EQUIPMENT	-

ORIGINAL DIAGRAMS FOR REFERENCE:-
BR 188

ISSUE DATE
4 MAR 87

BRAKES
 BOGIE/SUSPENSION
 BODY CONSTRUCTION
 COUPLINGS
 TRAIN HEATING
 E.T.H. INDEX
 MAX. SPEED M.P.H.
 MIN. RAD. CURVE CHAINS
 LIGHTING
 TARE WEIGHT TONNES
 GANGWAYS
 TRAIN COMMUNICATION
 BUFFERS

BASIC TYPE

AIR
 B4
 STEEL
 AUTOMATIC DROPHEAD(BUCKEYE)
 ELECTRIC(BR)FULL AIR CONDITIONING NOT SUITED TO CLASS 55 LOCOS
 5
 100
 3.5
 FLUORESCENT & TUNGSTEN
 33.5
 PULLMAN
 PUBLIC ADDRESS WITH TRANSMITTER
 RETRACTABLE SPINDLE(559X356 OVAL)

ALTERNATIVES

PUBLIC ADDRESS WITH TRANSMITTER, DRIVER GUARD

TRACTION DATA FOR MULTIPLE UNITS

BASIC TYPE

AE 207 0A

VARIANTS

1A DRIVER GUARD COMMUNICATION FITTED

BRAKE SECOND OPEN-MK 11F

CLASS ---

BS0

AE 208

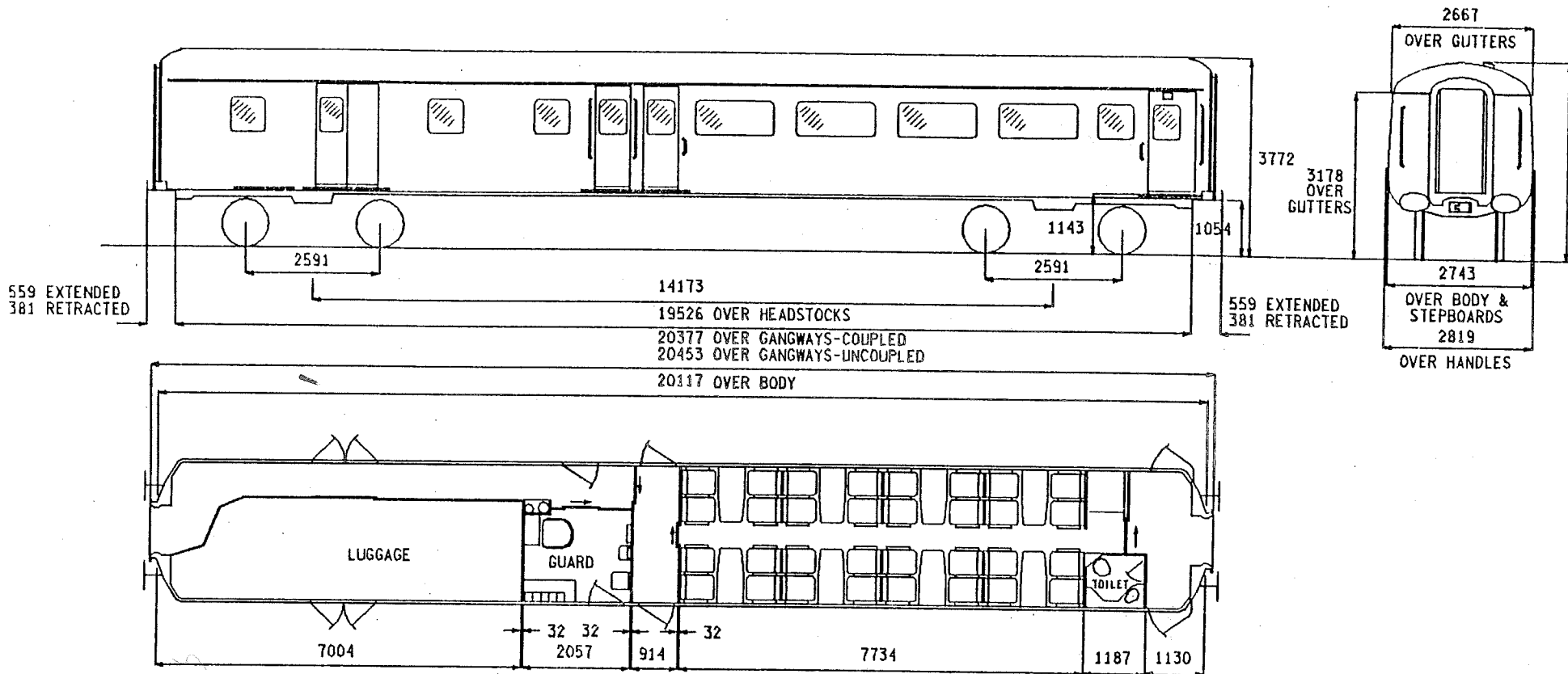

SEATS	32
TOILETS	1
COMPARTMENTS	-
GUARDS COMPARTMENTS	1
VENTILATION	FULL AIR CONDITIONING
CATERING EQUIPMENT	-

ORIGINAL DIAGRAMS FOR REFERENCE:-
BR 189

ISSUE 4 DATE MAR 87

AE 208

BASIC TYPE

ALTERNATIVES

BRAKES
BOGIE/SUSPENSION
BODY CONSTRUCTION
COUPLINGS
TRAIN HEATING
E.T.H. INDEX
MAX. SPEED M.P.H.
MIN. RAD. CURVE CHAINS
LIGHTING
TARE WEIGHT TONNES
GANGWAYS
TRAIN COMMUNICATION
BUFFERS

AIR
B4
STEEL
AUTOMATIC DROPHEAD(BUCKEYE)
ELECTRIC(BR)FULL AIR CONDITIONING
5 PLUS 600 AMP WIRING
100
3.5
FLUORESCENT & TUNGSTEN
33
PULLMAN
PUBLIC ADDRESS WITH TRANSMITTER
RETRACTABLE SPINDLE(559X356 OVAL)

PUBLIC ADDRESS WITH TRANSMITTER, DRIVER GUARD

TRACTION DATA FOR MULTIPLE UNITS

BASIC TYPE

AE 208 OA

VARIANTS

1A DRIVER GUARD COMMUNICATION FITTED

DRIVING BRAKE SECOND OPEN-MK 11F

CLASS ---

DBSO

AF 201

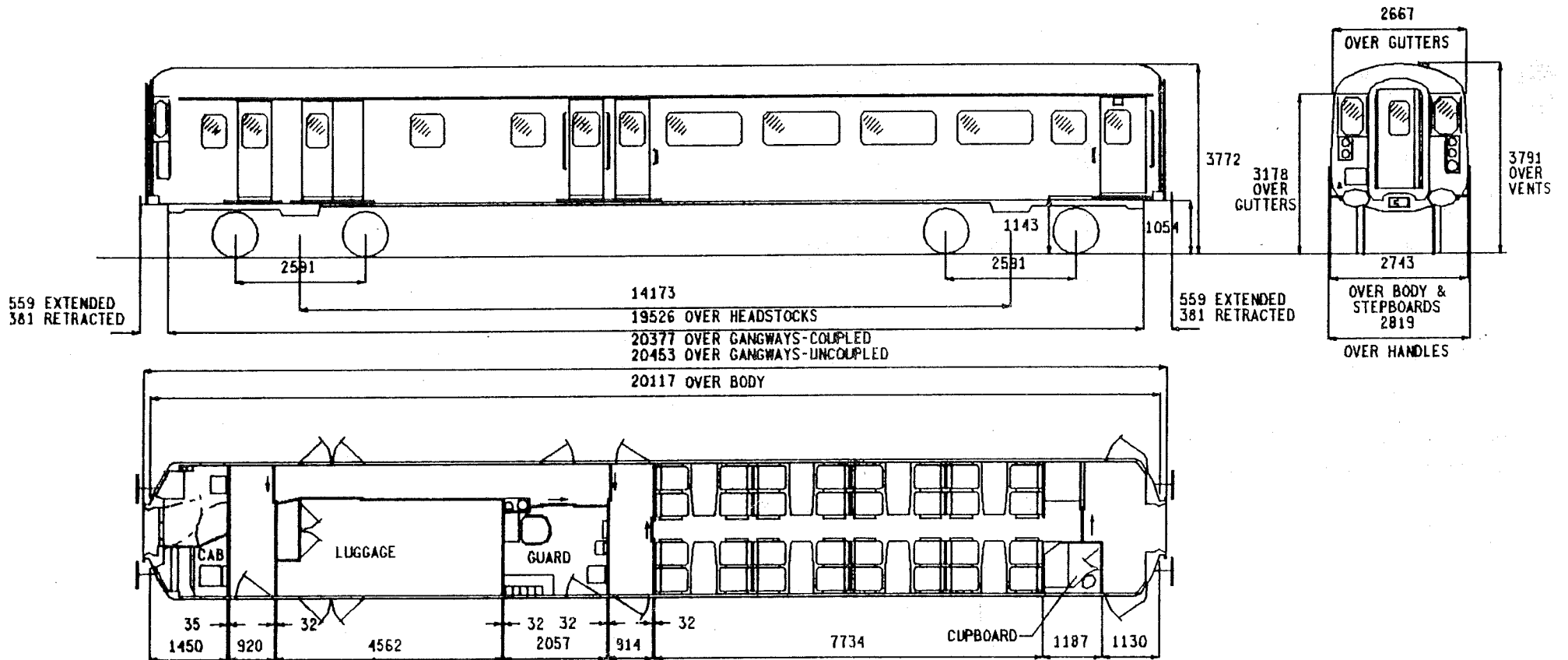

- SEATS 32
- TOILETS -
- COMPARTMENTS -
- GUARDS COMPARTMENTS 1
- VENTILATION FULL AIR CONDITIONING
- CATERING EQUIPMENT -

ORIGINAL DIAGRAMS FOR REFERENCE:-
BR 190

ISSUE 4 DATE JUN 85

AF 201

	<u>BASIC TYPE</u>	<u>ALTERNATIVES</u>
BRAKES	AIR	
BOGIE/SUSPENSION	BT21 & BT21a(ONE OF EACH)	B4
BODY CONSTRUCTION	STEEL	
COUPLINGS	AUTOMATIC DROPHEAD(BUCKEYE)	
TRAIN HEATING	ELECTRIC(BR)FULL AIR CONDITIONING	
E.T.H. INDEX	5 PLUS 600 AMP WIRING	
MAX.SPEED M.P.H.	100	
MIN.RAD.CURVE CHAINS	3.5	
LIGHTING	FLUORESCENT & TUNGSTEN	
TARE WEIGHT TONNES	33	
GANGWAYS	PULLMAN	
TRAIN COMMUNICATION	PUBLIC ADDRESS WITH TRANSMITTER	
BUFFERS	RETRACTABLE SPINDLE(559X356 OVAL)	
OBSTACLE DEFLECTORS	NOT FITTED	FITTED

TRACTION DATA FOR MULTIPLE UNITSBASIC TYPE

AF 201 0A

VARIANTS

- OB B4 BOGIES.
- OC OBSTACLE DEFLECTOR.
- OD B4 BOGIES,OBSTACLE DEFLECTOR

STANDARD OPEN WITH MICRO BUFFET-MKIIC

CLASS ---

TSOT

AG 201

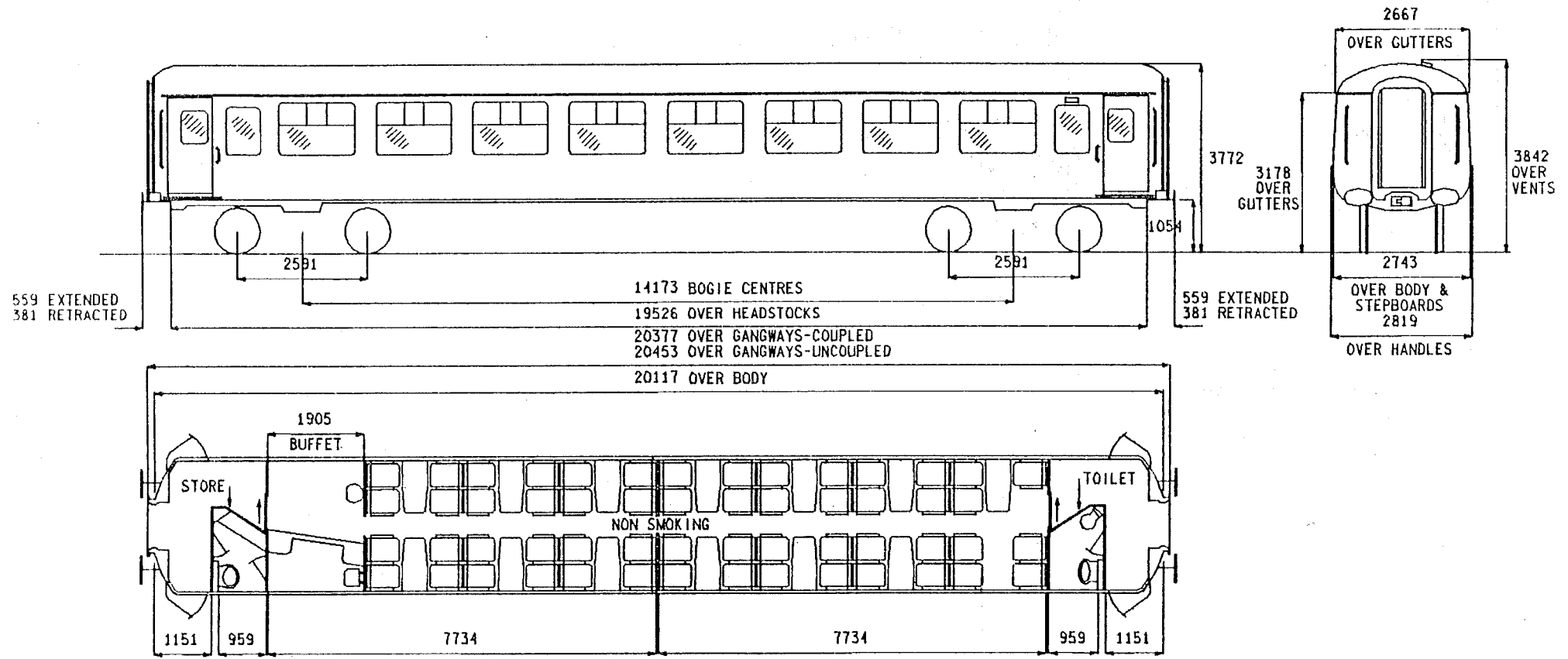

SEATS
 TOILETS
 COMPARTMENTS
 GUARDS COMPARTMENTS
 VENTILATION

ISSUE 2 DATE APR 88

AG 201

BASIC TYPE

BRAKES
BOGIE/SUSPENSION
BODY CONSTRUCTION
COUPLINGS
TRAIN HEATING
E.T.H. INDEX
MAX. SPEED M.P.H.
MIN. RAD. CURVE CHAINS
LIGHTING
TARE WEIGHT TONNES
GANGWAYS
TRAIN COMMUNICATION
BUFFERS

AIR
B4
STEEL
AUTOMATIC DROPHEAD(BUCKEYE)
DUAL(STEAM/ELECTRIC(BR))WITH PRESSURE VENTILATION & HEATING
4
100
3.5
FLUORESCENT & TUNGSTEN
32
PULLMAN
PUBLIC ADDRESS
RETRACTABLE SPINDLE(559 X 356 OVAL)

ALTERNATIVES

PUBLIC ADDRESS & TRANSMITTER

TRACTION DATA FOR MULTIPLE UNITS

BASIC TYPE

AG 201 OA

VARIANTS

1A PUBLIC ADDRESS & TRANSMITTER FITTED.

SECOND OPEN WITH MICRO BUFFET-MK IID

CLASS ---

TSOT

AG 202

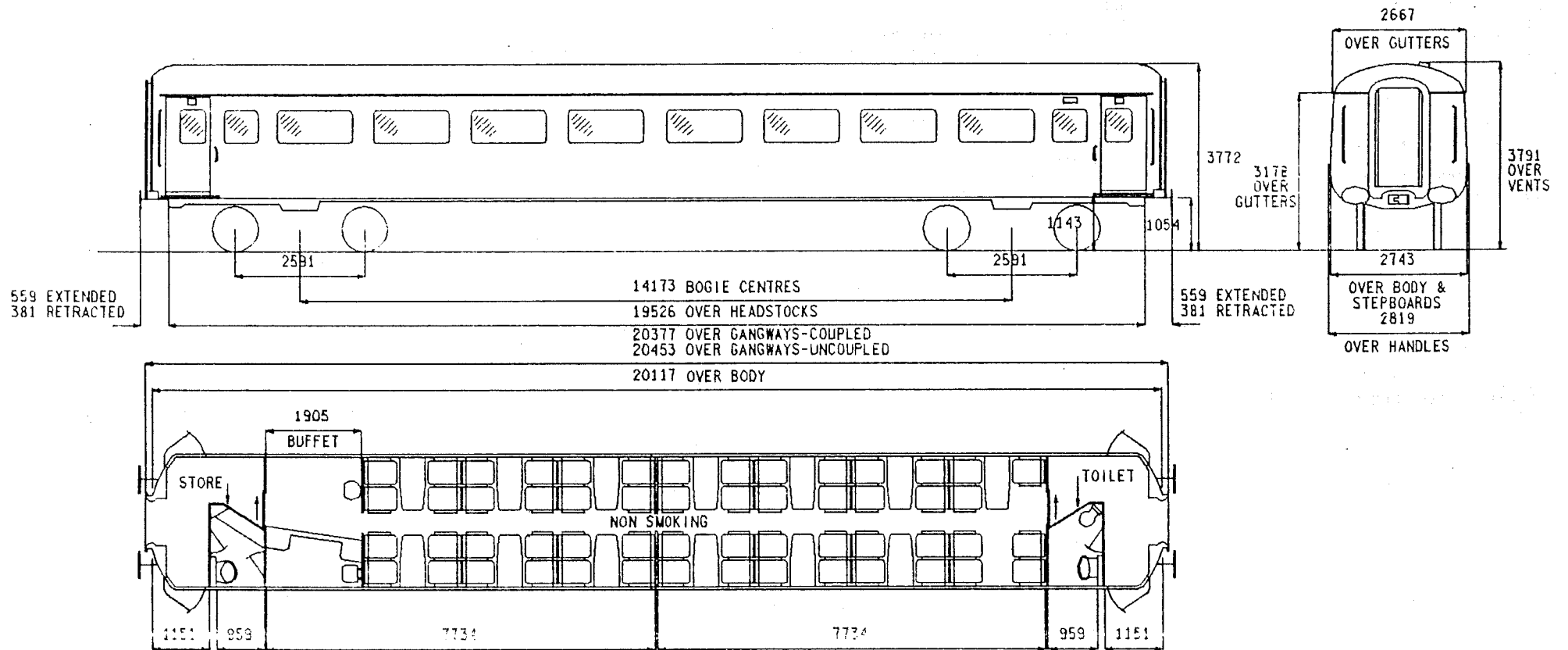

- SEATS 55
- TOILETS 1
- COMPARTMENTS -
- GUARDS COMPARTMENTS -
- VENTILATION FULL AIR CONDITIONING
- CATERING EQUIPMENT -

ISSUE 1 DATE MAY 84

AG 202

BRAKES
 BOGIE/SUSPENSION
 BODY CONSTRUCTION
 COUPLINGS
 TRAIN HEATING
 E.T.H. INDEX
 MAX.SPEED M.P.H.
 MIN.RAD.CURVE CHAINS
 LIGHTING
 TARE WEIGHT TONNES
 GANGWAYS
 TRAIN COMMUNICATION
 BUFFERS

BASIC TYPE

AIR
 B4
 STEEL
 AUTOMATIC DROPHEAD(BUCKEYE)
 ELECTRIC(BR)FULL AIR CONDITIONING
 5
 100
 3.5
 FLUORESCENT & TUNGSTEN
 33.5
 PULLMAN
 PUBLIC ADDRESS
 RETRACTABLE SPINDLE(559X356 OVAL)

ALTERNATIVES

TRACTION DATA FOR MULTIPLE UNITS

BASIC TYPE

AG 202 0A

VARIANTS

NONE

BRAKE SECOND OPEN-WITH MICRO BUFFET-MK 1

CLASS ---

BSOT

AH 202

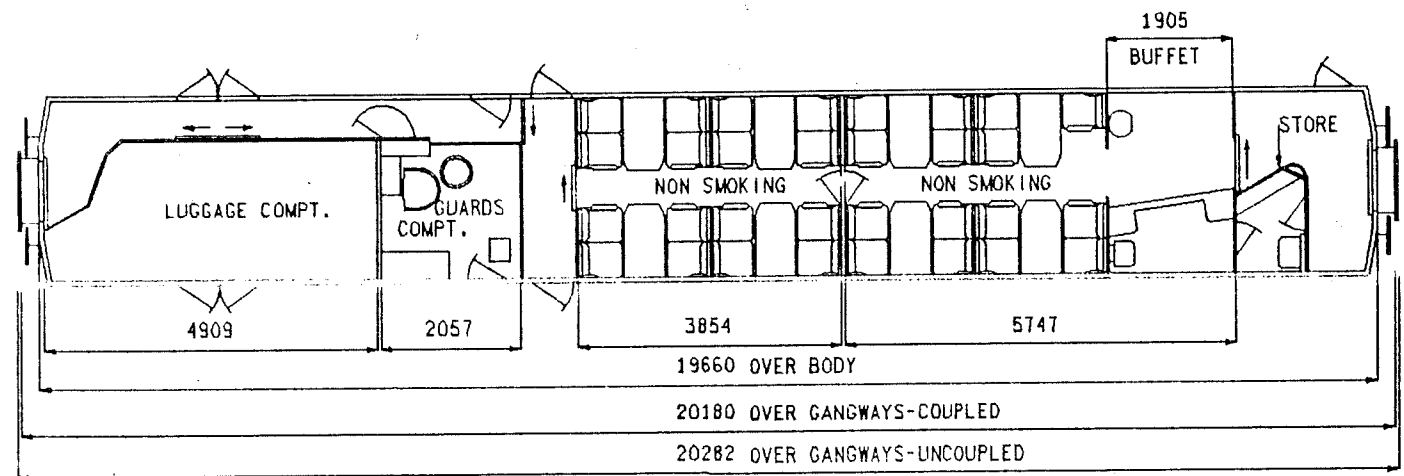
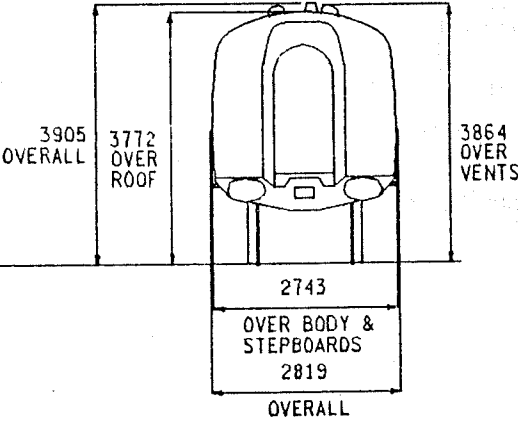
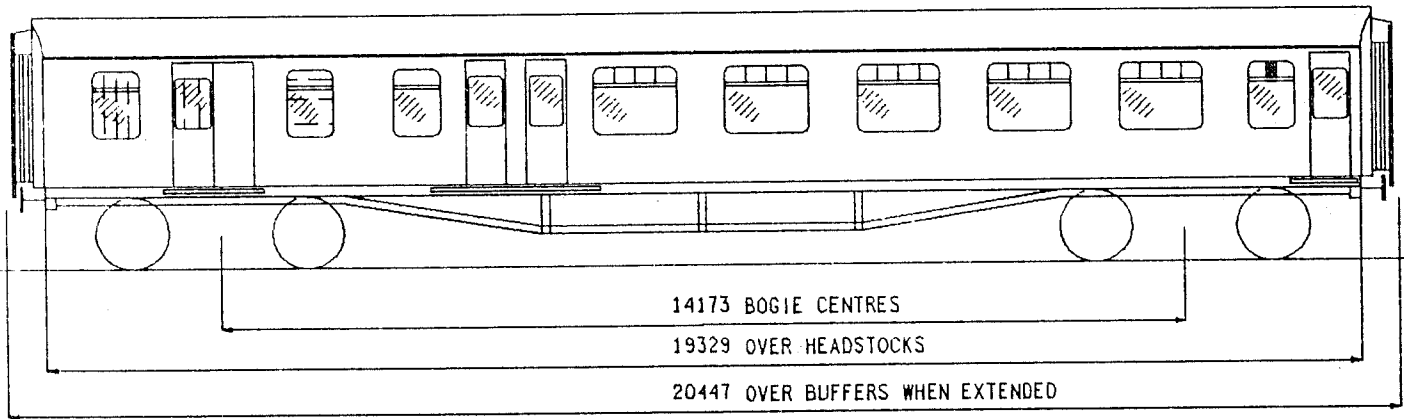

SEATS	31
TOILETS	-
COMPARTMENTS	-
GUARDS COMPARTMENTS	1
VENTILATION	-
CATERING EQUIPMENT	-

ISSUE 1 DATE MAY 84

AH 202

BRAKES
 BOGIE/SUSPENSION
 BODY CONSTRUCTION
 COUPLINGS
 TRAIN HEATING
 E.T.H. INDEX
 MAX. SPEED M.P.H.
 MIN. RAD. CURVE CHAINS
 LIGHTING
 TARE WEIGHT TONNES
 GANGWAYS
 TRAIN COMMUNICATION
 BUFFERS
 BRAKE BLOCKS

BASIC TYPE

VACUUM
 COMMONWEALTH
 STEEL
 AUTOMATIC DROPHEAD (BUCKEYE)
 STEAM
 -
 100
 3.5
 FLUORESCENT & TUNGSTEN
 36
 PULLMAN
 NOT FITTED
 RETRACTABLE SPINDLE (559X356 OVAL)
 CAST IRON

ALTERNATIVES

COMPOSITION

TRACTION DATA FOR MULTIPLE UNITS

BASIC TYPE

AH 202 0A

VARIANTS

OB COMPOSITION BRAKE BLOCKS.

BRAKE STANDARD OPEN-WITH MICRO BUFFET-MK 11

CLASS ---

BSOT

AH 203

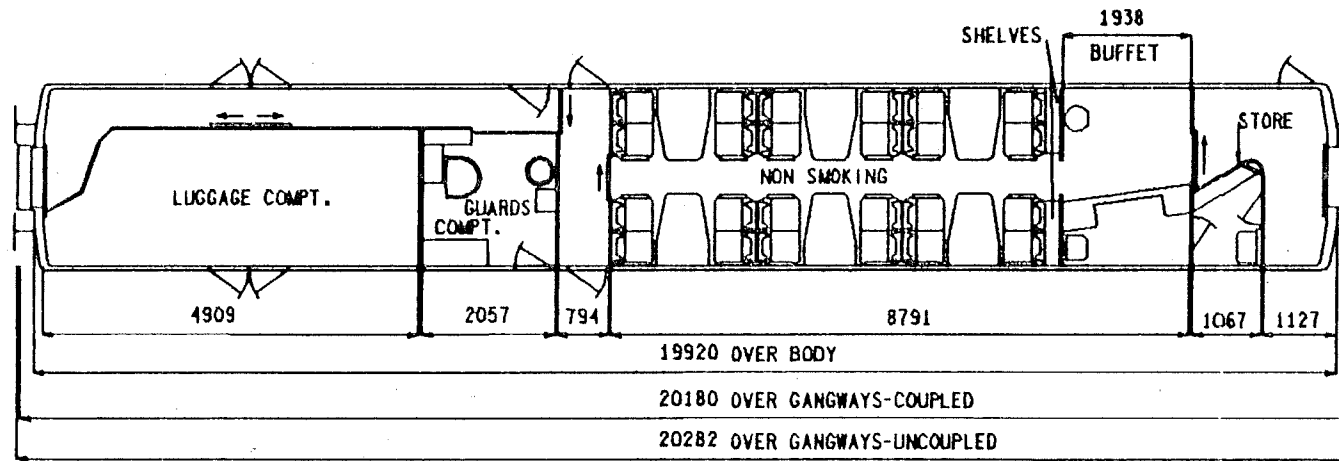
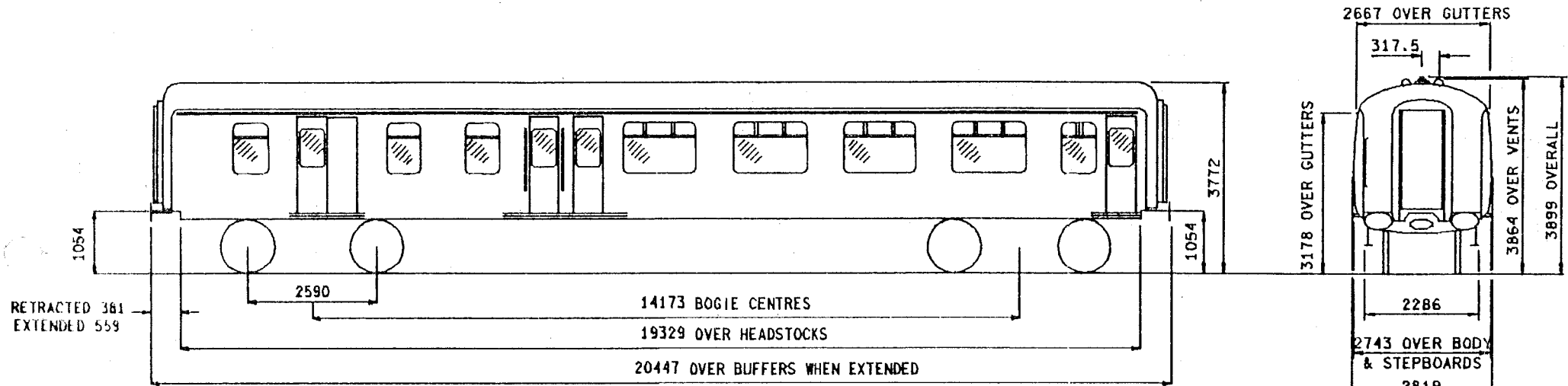

SEATS	24
TOILETS	-
COMPARTMENTS	-
GUARDS COMPARTMENTS	1
VENTILATION	-
CATERING EQUIPMENT	-

ISSUE 3 DATE MAR 88

AH 203

BRAKES
BOGIE/SUSPENSION
BODY CONSTRUCTION
COUPLINGS
TRAIN HEATING
E.T.H. INDEX
MAX.SPEED M.P.H.
MIN.RAD.CURVE CHAINS
LIGHTING
TARE WEIGHT TONNES
GANGWAYS
TRAIN COMMUNICATION
BUFFERS

BASIC TYPE

VACUUM
B4
STEEL
AUTOMATIC DROPHEAD(BUCKEYE)
DUAL(STEAM/ELECTRIC(BR))WITH PRESSURE VENTILATION & HEATING
4
100
3.5
FLUORESCENT & TUNGSTEN
32
PULLMAN
NOT FITTED
RETRACTABLE SPINDLE(559X356 OVAL)

ALTERNATIVES

TRACTION DATA FOR MULTIPLE UNITS

BASIC TYPE

AH 203 OA

VARIANTS

NONE

BRAKE STANDARD OPEN-WITH CATERING TROLLEY-MK 11

CLASS ---

BSOT

AH 204

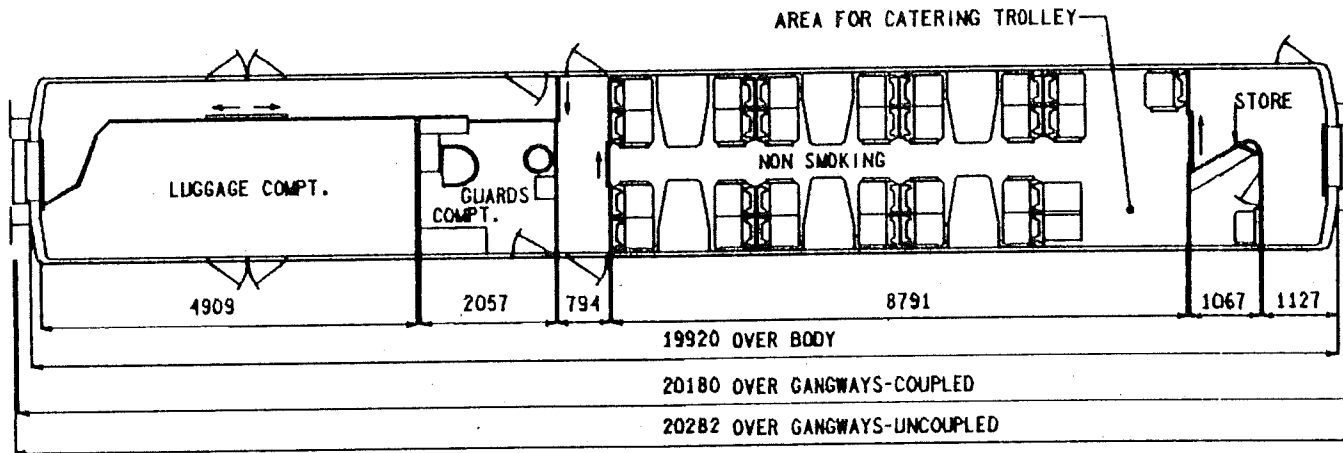
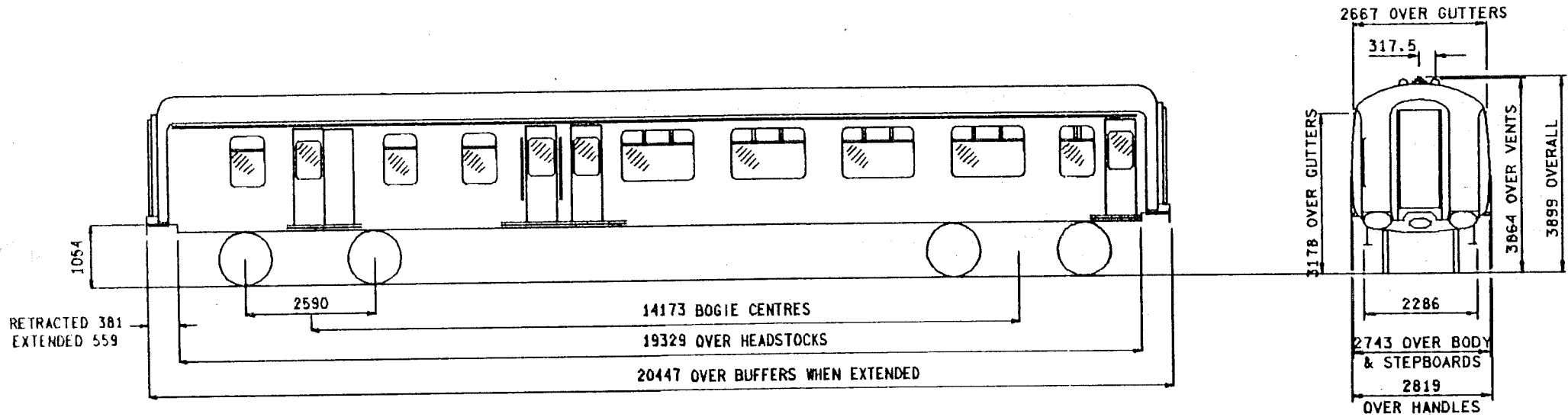

SEATS	27
TOILETS	-
COMPARTMENTS	-
GUARDS COMPARTMENTS	1
VENTILATION	-
CATERING EQUIPMENT	-

ISSUE 2 DATE MAR 88

AH 204

BRAKES
BOGIE/SUSPENSION
BODY CONSTRUCTION
COUPLINGS
TRAIN HEATING
E.T.H. INDEX
MAX.SPEED M.P.H.
MIN.RAD.CURVE CHAINS
LIGHTING
TARE WEIGHT TONNES
GANGWAYS
TRAIN COMMUNICATION
BUFFERS

BASIC TYPE

VACUUM
B4
STEEL
AUTOMATIC DROPHEAD(BUCKEYE)
DUAL(STEAM/ELECTRIC(BR))WITH PRESSURE VENTILATION & HEATING
4
100
3.5
FLUORESCENT & TUNGSTEN
32
PULLMAN
NOT FITTED
RETRACTABLE SPINDLE(559X356 OVAL)

ALTERNATIVES

TRACTION DATA FOR MULTIPLE UNITS

BASIC TYPE
AH 204 OA

VARIANTS
NONE

RESTAURANT FIRST BUFFET WITH KITCHEN - MK 111

CLASS ---

RFB

AJ 102

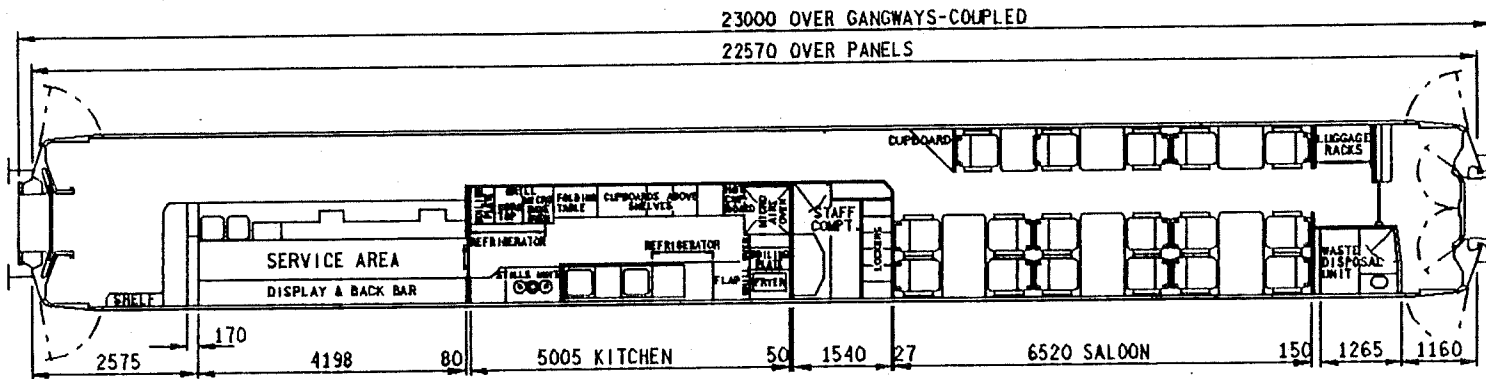
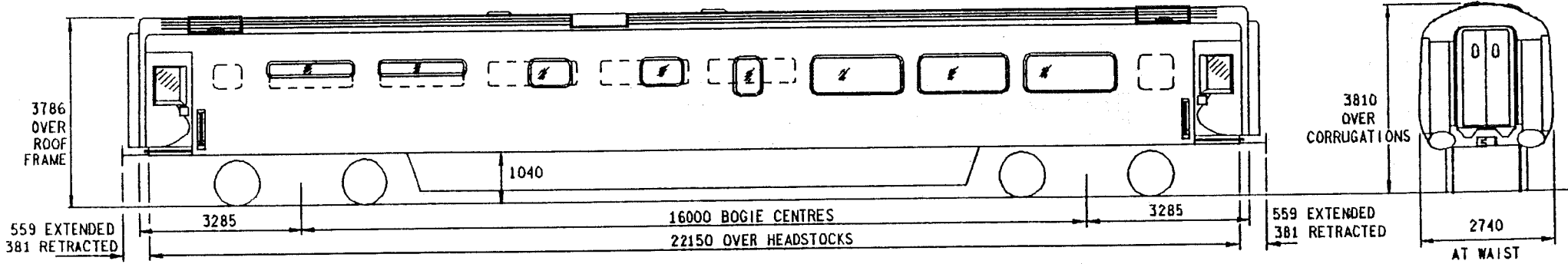

- | | |
|---------------------|-------------------------------|
| SEATS | 17 |
| TOILETS | - |
| COMPARTMENTS | - |
| GUARDS COMPARTMENTS | - |
| VENTILATION | FULL AIR CONDITIONING |
| CATERING EQUIPMENT | ELECTRIC-MICROWAVE, MICROAIRE |

ORIGINAL DIAGRAMS FOR REFERENCE:
BR 43

ISSUE 2 DATE DEC 85

AJ 102

BASIC TYPE

ALTERNATIVES

BRAKES
BOGIE/SUSPENSION
BODY CONSTRUCTION
COUPLINGS
TRAIN HEATING
E.T.H. INDEX
MAX.SPEED M.P.H.
MIN.RAD.CURVE CHAINS
LIGHTING
TARE WEIGHT TONNES
GANGWAYS
TRAIN COMMUNICATION
BUFFERS
SEATS

AIR
BT10/BT10a (ONE OF EACH)
STEEL
AUTOMATIC DROP HEAD (BUCKEYE)
ELECTRIC(BR)FULL AIR CONDITIONING
16 PLUS 600 AMP WIRING
125
4.5
FLUORESCENT & TUNGSTEN
39
CENTRALLY SUPPORTED-SWIVELLING-FLEXIBLE DIAPHRAGM-STEEL FACE PLATE
PUBLIC ADDRESS
RETRACTABLE SPINDLE 559x356 OVAL HEAD
IC 80

TRACTION DATA FOR MULTIPLE UNITS

BASIC TYPE

AJ 102 0A

VARIANTS

NONE

RESTAURANT FIRST MODULAR-MK 111

RFM

AJ 103

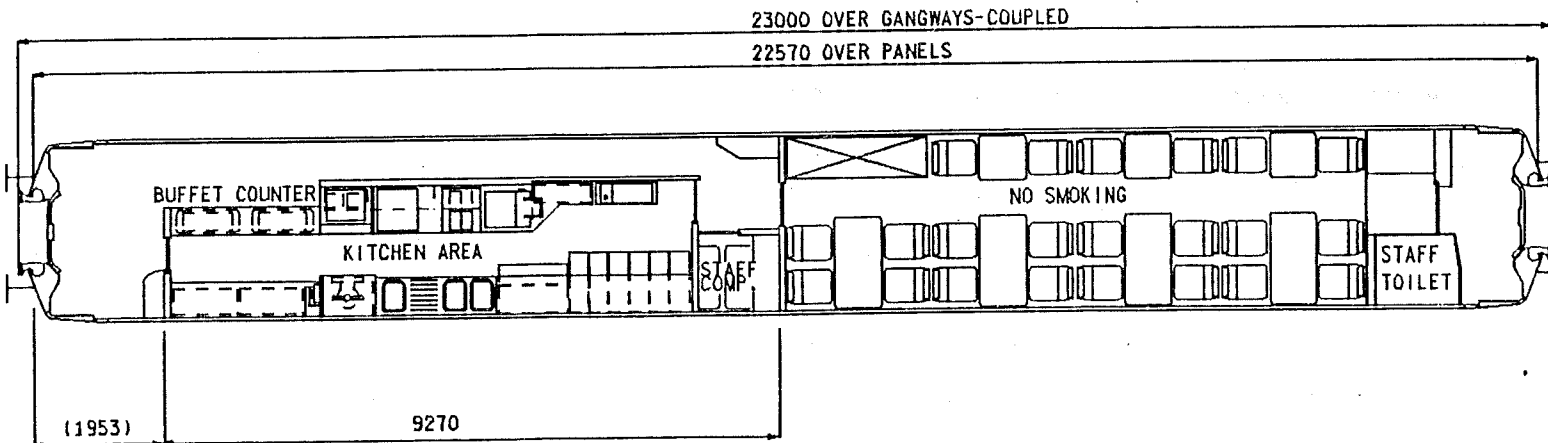
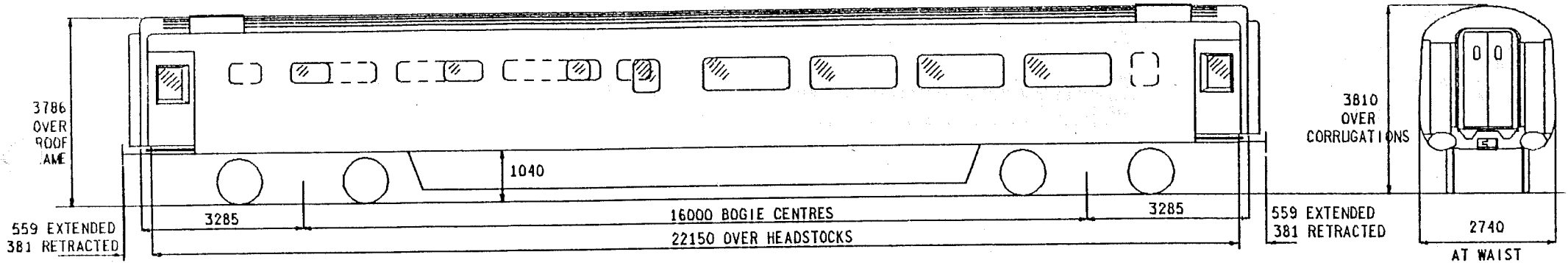

- | | |
|---------------------|-----------------------|
| SEATS | 22 |
| TOILETS | 1 |
| COMPARTMENTS | - |
| GUARDS COMPARTMENTS | - |
| VENTILATION | FULL AIR CONDITIONING |
| CATERING EQUIPMENT | ELECTRIC-MICROWAVE |

ISSUE 1 DATE JUL 87

AJ 103

BRAKES
 BOGIE/SUSPENSION
 BODY CONSTRUCTION
 COUPLINGS
 TRAIN HEATING
 MAX.SPEED M.P.H.
 MIN.RAD.CURVE CHAINS
 LIGHTING
 TARE WEIGHT TONNES
 GANGWAYS
 TRAIN COMMUNICATION
 BUFFERS

BASIC TYPE

AIR
 BT10a
 STEEL
 AUTOMATIC DROP HEAD (BUCKEYE)
 ELECTRIC(BR)FULL AIR CONDITIONING
 125
 4.5
 FLUORESCENT & TUNGSTEN
 39.8
 CENTRALLY SUPPORTED-SWIVELLING-FLEXIBLE DIAPHRAGM-STEEL FACE PLATE
 PUBLIC ADDRESS
 RETRACTABLE SPINDLE 559x356 OVAL HEAD

ALTERNATIVES

TRACTION DATA FOR MULTIPLE UNITS

HST-TRUK

INTRODUCED 1978,-MODIFIED TO RESTAURANT FIRST MODULAR 1985 (LOCO HAULED)

BASIC TYPE

AJ 103 0A

VARIANTS

NONE

RESTAURANT FIRST OPEN MK 11f

CLASS ---

RFO

AJ 104

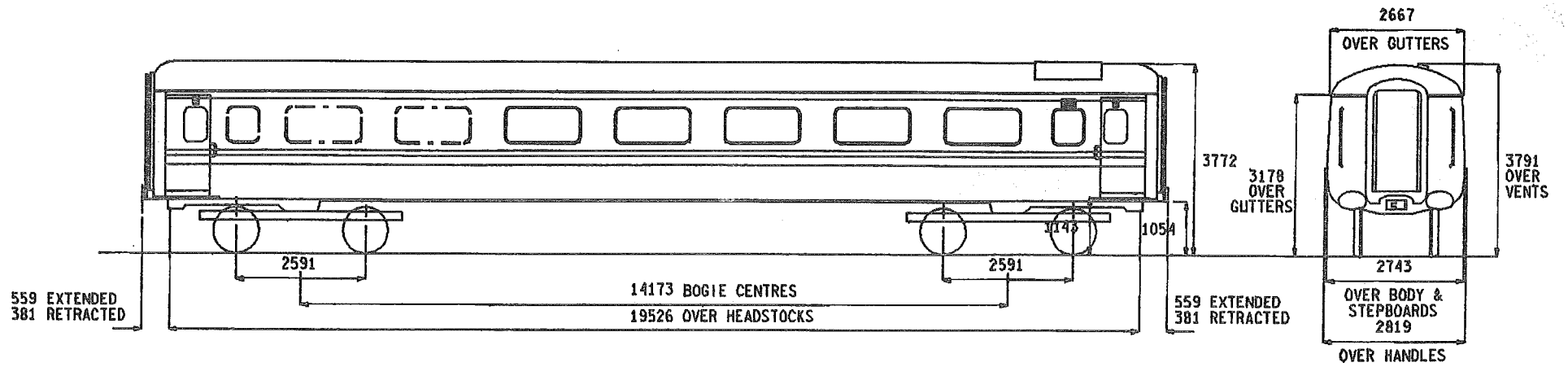

20377 OVER GANGWAYS-COUPLED
20453 OVER GANGWAYS-UNCOUPLED
20117 OVER BODY

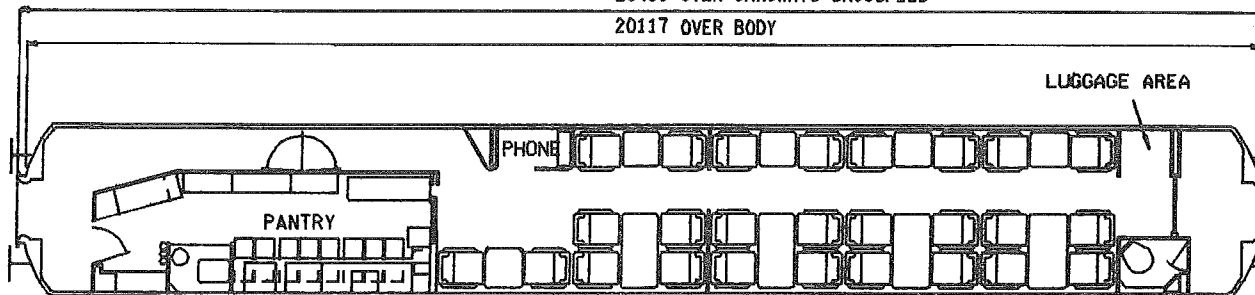

- | | |
|---------------------|-----------------------|
| SEATS | 26 |
| TOILETS | 1 |
| COMPARTMENTS | - |
| GUARDS COMPARTMENTS | - |
| VENTILATION | FULL AIR CONDITIONING |
| CATERING EQUIPMENT | MODULAR |

ISSUE 1
DATE JUL 88

AJ 104

BASIC TYPE

ALTERNATIVES

BRAKES
BOGIE/SUSPENSION
BODY CONSTRUCTION
COUPLINGS
TRAIN HEATING
E.T.H. INDEX
MAX. SPEED M.P.H.
MIN. RAD. CURVE CHAINS
LIGHTING
TARE WEIGHT TONNES
GANGWAYS
TRAIN COMMUNICATION
BUFFERS

AIR
B4
STEEL
AUTOMATIC DROPHEAD(BUCKEYE)
ELECTRIC(BR)FULL AIR CONDITIONING
5 PLUS 600 AMP WIRING
100
3.5
HALOGEN SPOT LAMPS PLUS FLUORESCENT & TUNGSTEN
35(EST)
PULLMAN
PUBLIC ADDRESS WITH TRANSMITTER
RETRACTABLE SPINDLE(559X356 OVAL)

TRACTION DATA FOR MULTIPLE UNITS

BASIC TYPE

AJ 104 0A

VARIANTS

NONE

REFRESHMENT FIRST OPEN MK 11f

CLASS ---

RFO

AJ 104

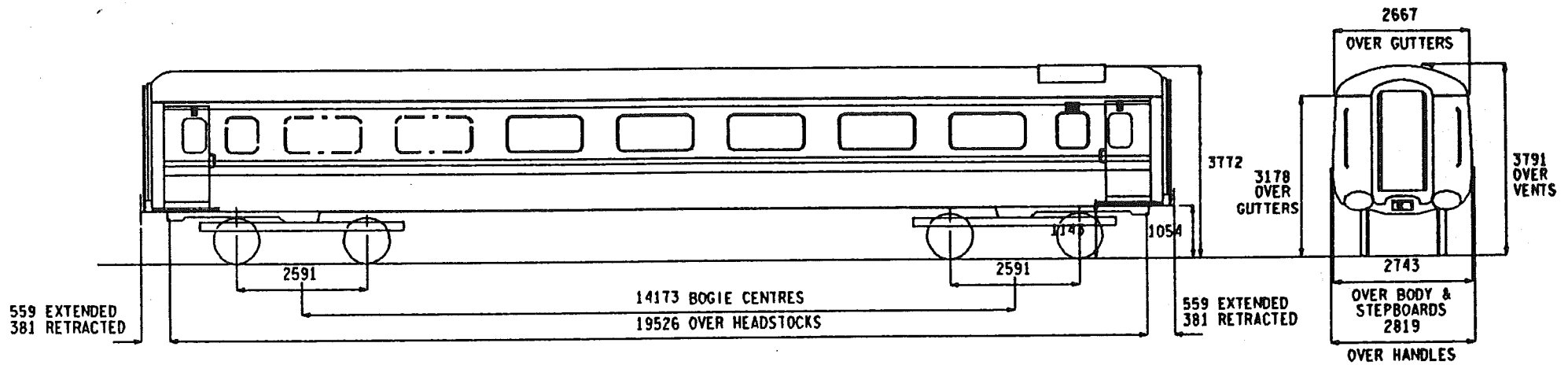

20377 OVER GANGWAYS-COUPLED
20453 OVER GANGWAYS-UNCOUPLED

20117 OVER BODY

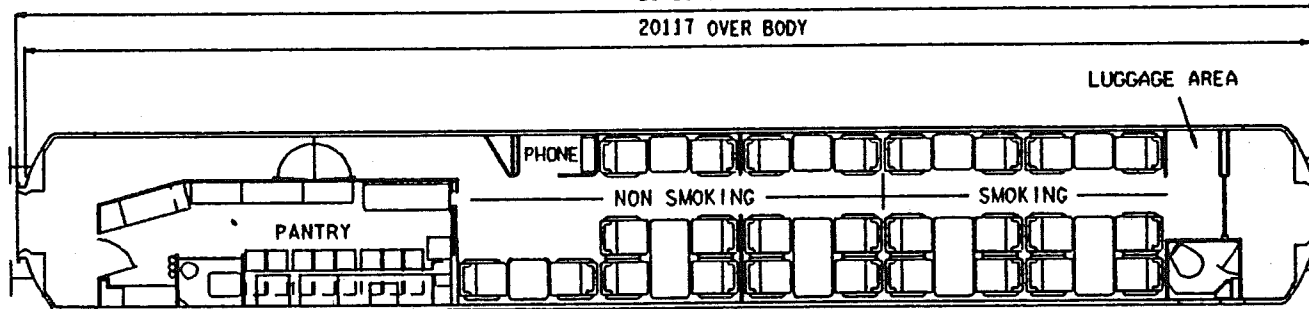

- | | |
|---------------------|-----------------------|
| SEATS | 26 |
| TOILETS | 1 |
| COMPARTMENTS | - |
| GUARDS COMPARTMENTS | - |
| VENTILATION | FULL AIR CONDITIONING |
| CATERING EQUIPMENT | MODULAR |

ISSUE 2 DATE MAR 89

AJ 104

BASIC TYPE

ALTERNATIVES

BRAKES
BOGIE/SUSPENSION
BODY CONSTRUCTION
COUPLINGS
TRAIN HEATING
E.T.H. INDEX
MAX. SPEED M.P.H.
MIN. RAD. CURVE CHAINS
LIGHTING
TARE WEIGHT TONNES
GANGWAYS
TRAIN COMMUNICATION
BUFFERS

AIR
B4
STEEL
AUTOMATIC DROPHEAD(BUCKEYE)
ELECTRIC(BR)FULL AIR CONDITIONING
6
100
3.5
HALOGEN SPOT LAMPS PLUS FLUORESCENT & TUNGSTEN
35(EST)
PULLMAN
PUBLIC ADDRESS WITH TRANSMITTER
RETRACTABLE SPINDLE(559X356 OVAL)

TRACTION DATA FOR MULTIPLE UNITS

BASIC TYPE

AJ 104 0A

VARIANTS

NONE

RESTAURANT BUFFET WITH KITCHEN-UNCLASSSED-MK 1

CLASS ---

RBR

AJ 403

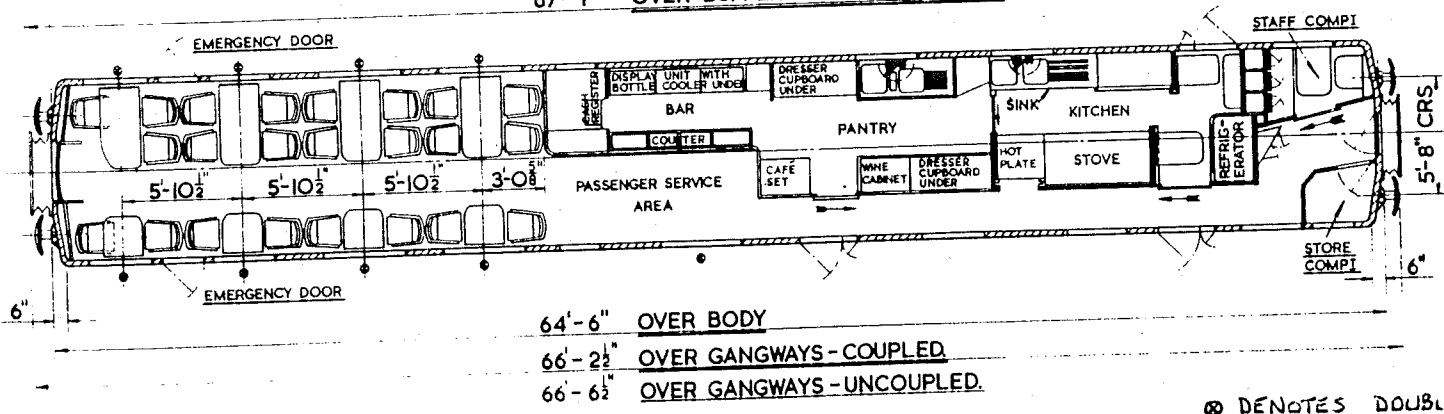
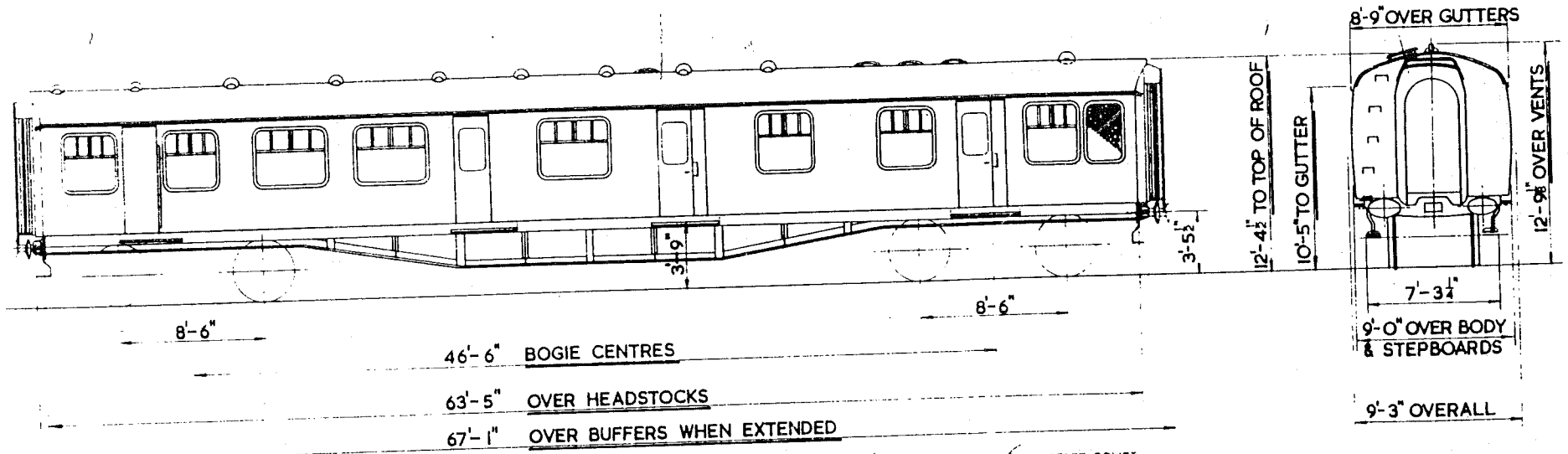

⊗ DENOTES DOUBLE GLAZED WINDOWS

SEATS	23
TOILETS	-
COMPARTMENTS	-
GUARDS COMPARTMENTS	-
VENTILATION	-
CATERING EQUIPMENT	LIQUID GAS

ORIGINAL DIAGRAMS FOR REFERENCE:-
BR 33

ISSUE 6 DATE DEC 85

AJ 403

BASIC TYPE

BRAKES
BOGIE/SUSPENSION
BODY CONSTRUCTION
COUPLINGS
TRAIN HEATING
E.T.H. INDEX
MAX. SPEED M.P.H.
MIN. RAD. CURVE CHAINS
LIGHTING
TARE WEIGHT TONNES
GANGWAYS
TRAIN COMMUNICATION

BUFFERS
BRAKE BLOCKS

AIR
COMMONWEALTH
STEEL
AUTOMATIC DROPHEAD (BUCKEYE)
DUAL (STEAM/ELECTRIC (BR))
2
100
3.5
FLUORESCENT & TUNGSTEN
39
PULLMAN
PUBLIC ADDRESS

RETRACTABLE SPINDLE (559X356 OVAL)
CAST IRON

ALTERNATIVES

VACUUM & AIR
B5

ELECTRIC (BR)
2 PLUS 600 AMP WIRING

NOT FITTED, PUBLIC ADDRESS WITH TRANSMITTER, PUBLIC
ADDRESS TRANSMITTER ONLY

COMPOSITION

TRACTION DATA FOR MULTIPLE UNITSBASIC TYPE

AJ 403 0A

VARIANTS

0B B5 BOGIES.
0D B5 BOGIES, VACUUM & AIR BRAKES.
2C VACUUM & AIR BRAKES, E.T.H. 2 PLUS 600 AMP WIRING, PUBLIC ADDRESS NOT FITTED.
4A PUBLIC ADDRESS NOT FITTED.
4B B5 BOGIES, PUBLIC ADDRESS NOT FITTED.
4F VACUUM & AIR BRAKES, PUBLIC ADDRESS NOT FITTED, COMPOSITION BRAKE BLOCKS.
5C VACUUM & AIR BRAKES, E.T.H. 2 PLUS 600 AMP WIRING, PUBLIC ADDRESS TRANSMITTER ONLY.
6A PUBLIC ADDRESS WITH TRANSMITTER.
6B B5 BOGIES, PUBLIC ADDRESS NOT FITTED.
6C VACUUM & AIR BRAKES, PUBLIC ADDRESS WITH TRANSMITTER.
6D VACUUM & AIR BRAKES, PUBLIC ADDRESS WITH TRANSMITTER, B5 BOGIES.
7A ELECTRIC (BR) HEATING, PUBLIC ADDRESS WITH TRANSMITTER.
8C VACUUM & AIR BRAKES, PUBLIC ADDRESS WITH TRANSMITTER, E.T.H. 2 PLUS 600 AMP WIRING.
9A PUBLIC ADDRESS TRANSMITTER ONLY.

RESTAURANT BUFFET WITH KITCHEN-UNCLASSIFIED-MK I

CLASS ---

RBK.

AJ 404

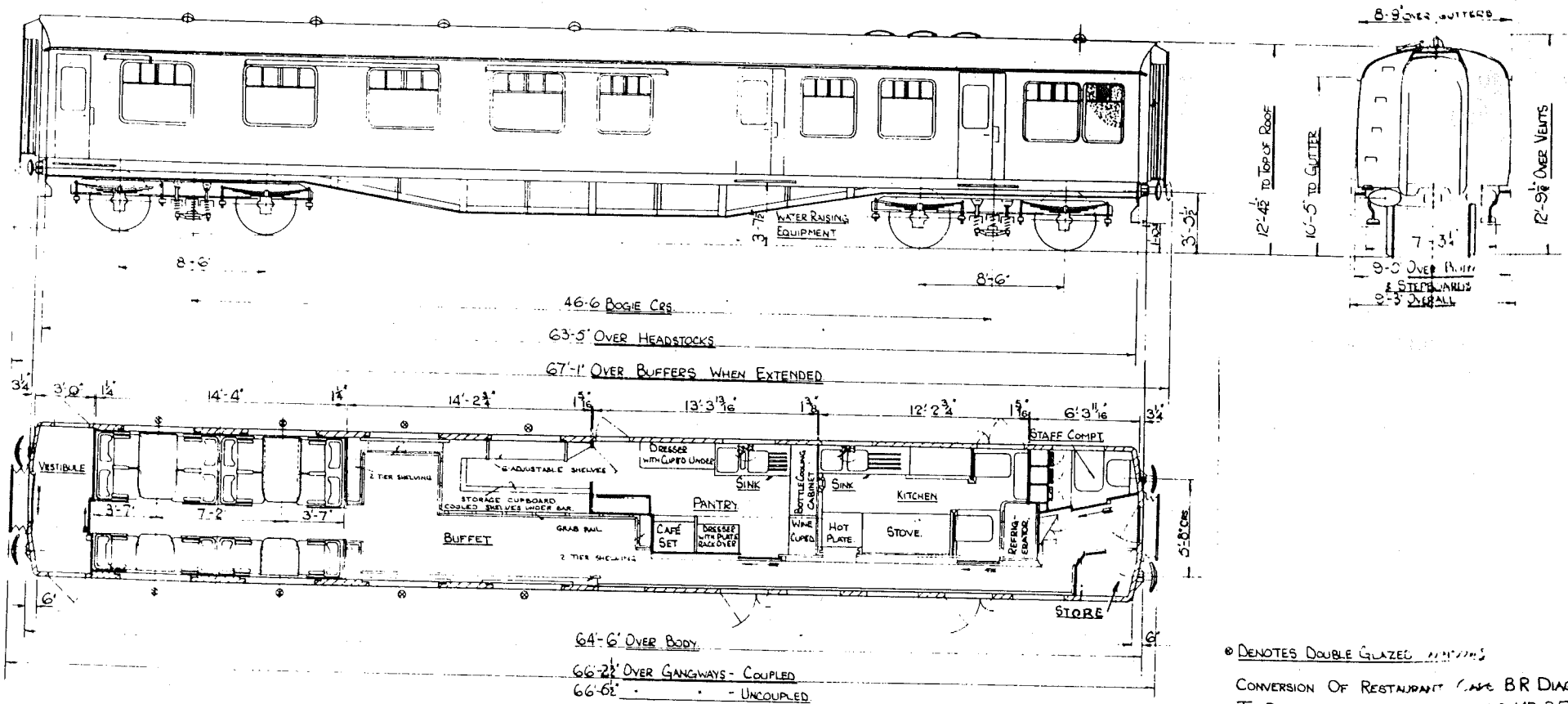

⊙ DENOTES DOUBLE GLAZED WINDOWS
 CONVERSION OF RESTAURANT CAFE BR DIAG.17
 TO REST. BUFFET ON B.P. M.V. NO MB 3540/3

SEATS	12
TOILETS	-
COMPARTMENTS	-
GUARDS COMPARTMENTS	-
VENTILATION	-
CATERING EQUIPMENT	LIQUID GAS

ORIGINAL DIAGRAMS FOR REFERENCE - BR 26

ISSUE 2 DATE MAY 81

AJ 404

BRAKES
 BOGIE/SUSPENSION
 BODY CONSTRUCTION
 COUPLINGS
 TRAIN HEATING
 E. T. H. INDEX
 MAX. SPEED M. P. H.
 MIN. RAD. CURVE CHAINS
 LIGHTING
 TARE WEIGHT TONNES
 GANGWAYS
 TRAIN COMMUNICATION
 BUFFERS

BASIC TYPE

VACUUM
 COMMONWEALTH
 STEEL
 AUTOMATIC DROPHEAD (BUCKEYE)
 DUAL (STEAM/ELECTRIC (BR))
 2
 100
 3.5
 TUNGSTEN
 40
 PULLMAN
 NOT FITTED
 RETRACTABLE SPINDLE (559X356 OVAL)

ALTERNATIVES

TRACTION DATA FOR MULTIPLE UNITS

BASIC TYPE

AJ 404 OD

VARIANTS

NONE

RESTAURANT BUFFET WITH KITCHEN-UNCLASSED-MK I

CLASS ---

RBR

AJ 408

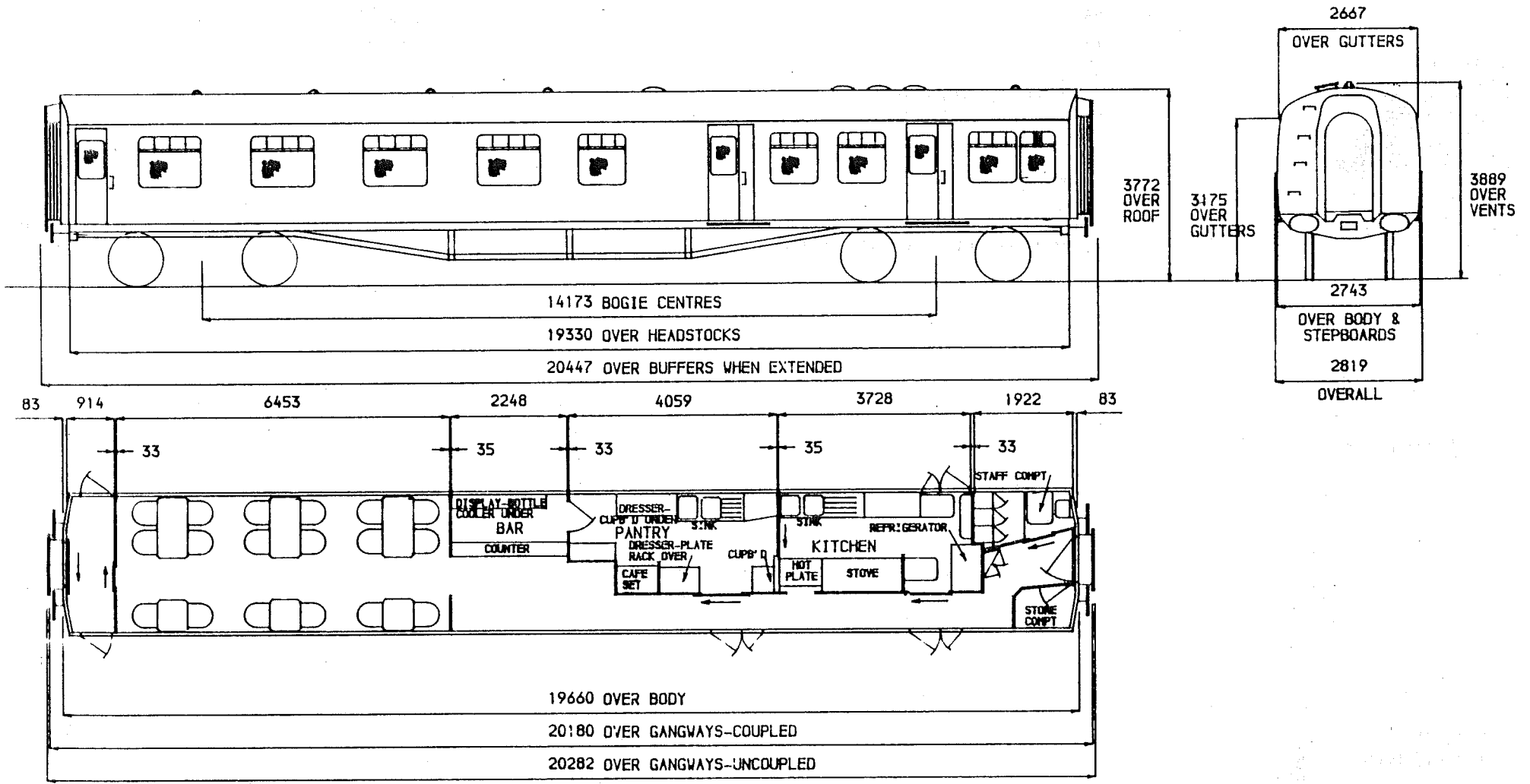

SEATS	18
TOILETS	-
COMPARTMENTS	-
GUARDS COMPARTMENTS	-
VENTILATION	-
CATERING EQUIPMENT	LIQUID GAS

ISSUE DATE
 1 SEP' 80

AJ 408

BRAKES
 BOGIE/SUSPENSION
 BODY CONSTRUCTION
 COUPLINGS
 TRAIN HEATING
 E.T.H. INDEX
 MAX. SPEED M.P.H.
 MIN. RAD. CURVE CHAINS
 LIGHTING
 TARE WEIGHT TONNES
 GANGWAYS
 TRAIN COMMUNICATION
 BUFFERS

BASIC TYPE

AIR
 COMMONWEALTH
 STEEL
 AUTOMATIC DROPHEAD (BUCKEYE)
 DUAL (STEAM/ELECTRIC (BR))
 2
 100
 3.5
 FLUORESCENT & TUNGSTEN
 40
 PULLMAN
 NOT FITTED
 RETRACTABLE SPINDLE (559X356 OVAL)

ALTERNATIVES

VACUUM & AIR

PUBLIC ADDRESS, PUBLIC ADDRESS WITH TRANSMITTER

TRACTION DATA FOR MULTIPLE UNITS

BASIC TYPE

AJ 408 0A-REFURBISHED

VARIANTS

- 0B REFURBISHED-VACUUM & AIR BRAKES.
- 1A REFURBISHED-PUBLIC ADDRESS.
- 2A REFURBISHED-PUBLIC ADDRESS WITH TRANSMITTER.

RESTAURANT BUFFET WITH KITCHEN-UNCLASSSED-MK I

CLASS ---

RBR

AJ 414

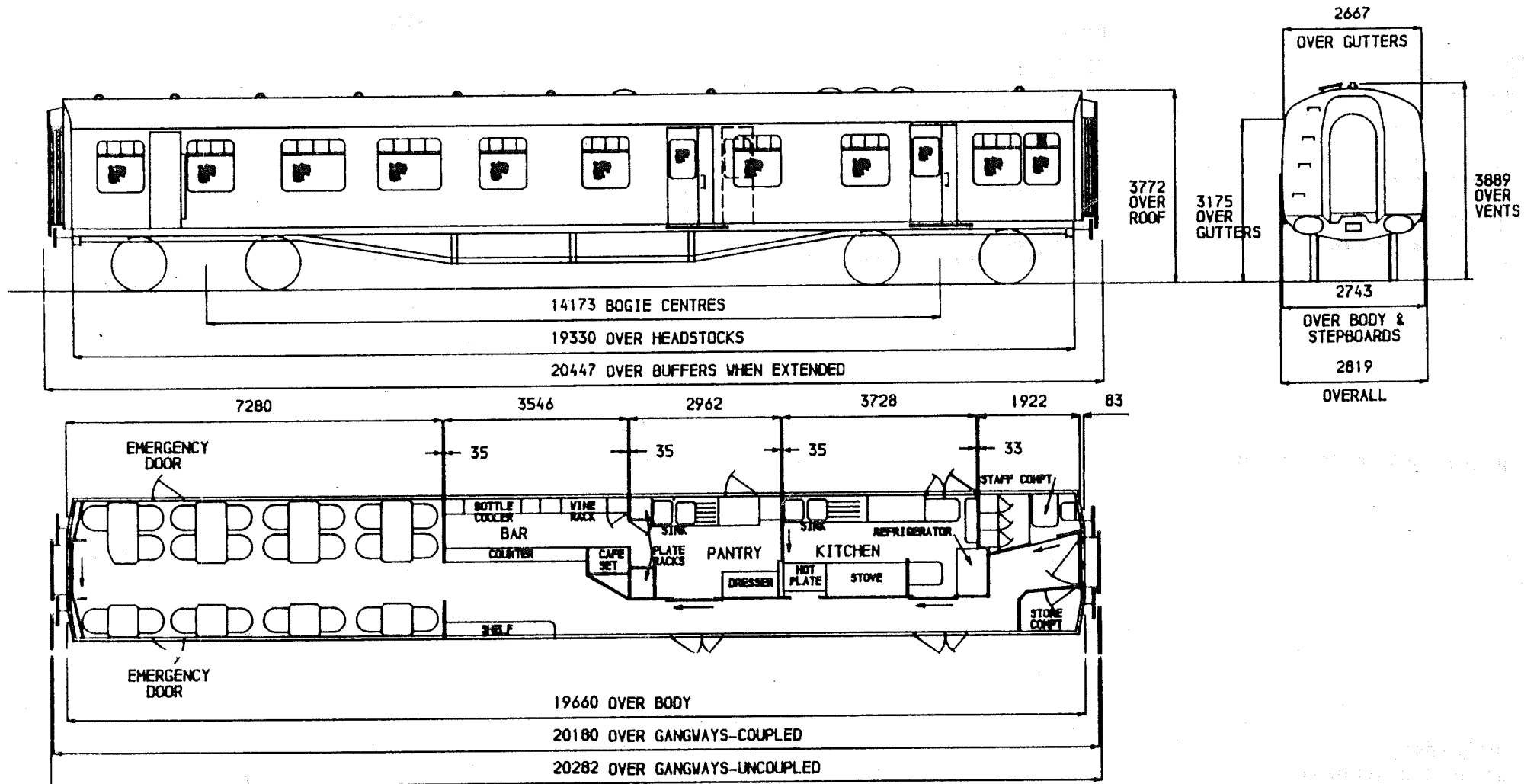

- SEATS 23
- TOILETS -
- COMPARTMENTS -
- GUARDS COMPARTMENTS -
- VENTILATION -
- CATERING EQUIPMENT LIQUID GAS

ISSUE 2 DATE MAY '81

AJ 414

BRAKES
 BOGIE/SUSPENSION
 BODY CONSTRUCTION
 COUPLINGS
 TRAIN HEATING
 E.T.H. INDEX
 MAX. SPEED M.P.H.
 MIN. RAD. CURVE CHAINS
 LIGHTING
 TARE WEIGHT TONNES
 GANGWAYS
 TRAIN COMMUNICATION
 BUFFERS

BASIC TYPE

VACUUM & AIR
 B4 & B5 (ONE OF EACH)
 STEEL
 AUTOMATIC DROPHEAD (BUCKEYE)
 DUAL (STEAM/ELECTRIC (BR))
 2 PLUS 600 AMP WIRING
 100
 3.5
 FLUORESCENT & TUNGSTEN
 36
 PULLMAN
 NOT FITTED
 RETRACTABLE SPINDLE (559X356 OVAL)

ALTERNATIVES

AIR
 COMMONWEALTH

2

35

NOT FITTED

TRACTION DATA FOR MULTIPLE UNITSBASIC TYPE

AJ 414 0A-REFURBISHED

VARIANTS

- 1B REFURBISHED-AIR BRAKES, ETH 2, PUBLIC ADDRESS.
- 1C REFURBISHED-AIR BRAKES, ETH 2, PUBLIC ADDRESS, COMMONWEALTH BOGIES.
- 2B REFURBISHED-AIR BRAKES, ETH 2, PUBLIC ADDRESS WITH TRANSMITTER.
- 2C REFURBISHED-AIR BRAKES, ETH 2, PUBLIC ADDRESS WITH TRANSMITTER, COMMONWEALTH BOGIES, TARE 35.

RESTAURANT BUFFET WITH KITCHEN-UNCLASSSED-MK I

CLASS ----

RBR

AJ 415

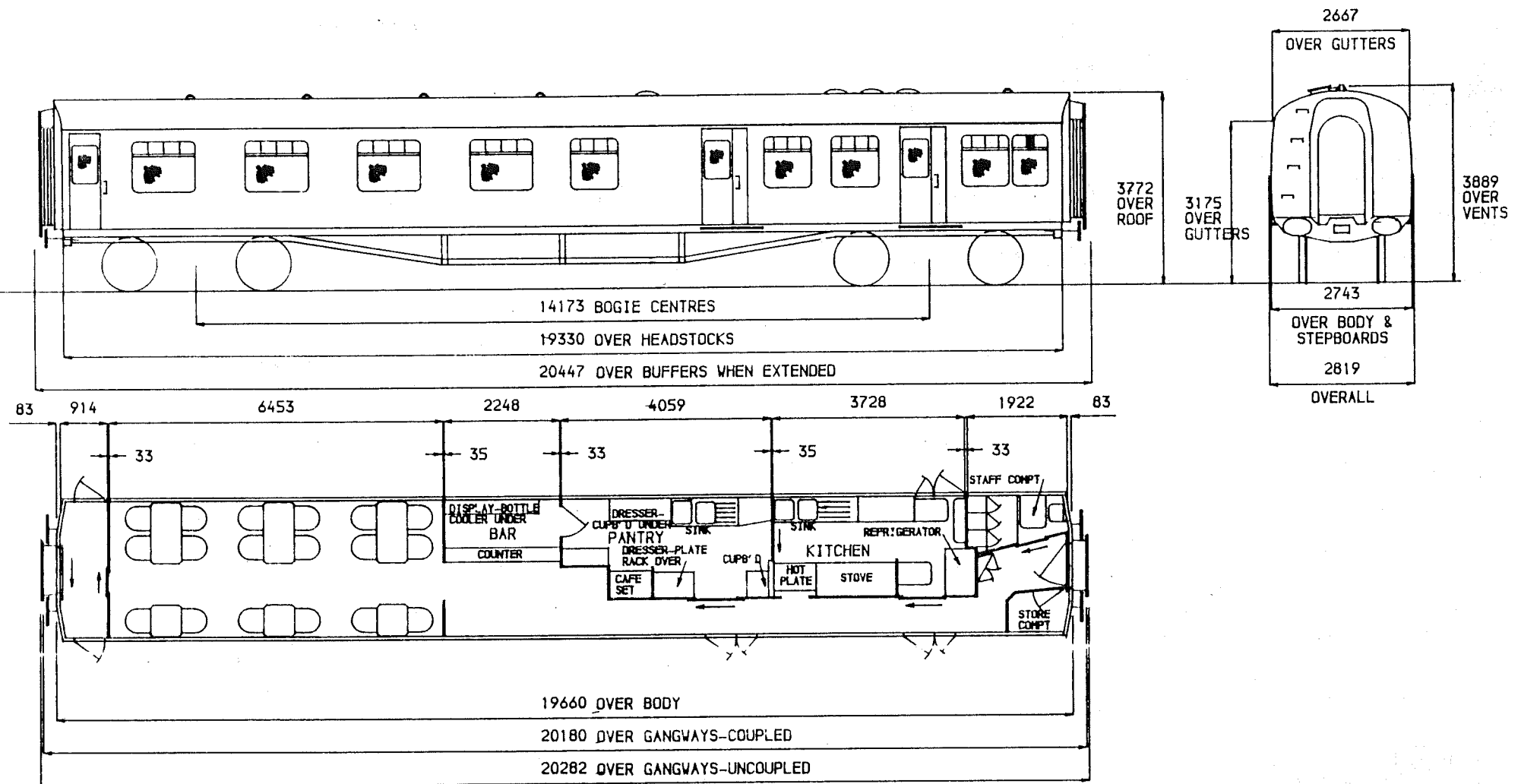

- SEATS 18
- TOILETS -
- COMPARTMENTS -
- GUARDS COMPARTMENTS -
- VENTILATION -
- CATERING EQUIPMENT LIQUID GAS

ISSUE 1 DATE SEP' 80

AJ 415

BASIC TYPE

BRAKES
BOGIE/SUSPENSION
BODY CONSTRUCTION
COUPLINGS
TRAIN HEATING
E.T.H. INDEX
MAX. SPEED M.P.H.
MIN. RAD. CURVE CHAINS
LIGHTING
TARE WEIGHT TONNES
GANGWAYS
TRAIN COMMUNICATION
BUFFERS

AIR
COMMONWEALTH
STEEL
AUTOMATIC DROPHEAD (BUCKEYE)
DUAL (STEAM/ELECTRIC (BR))
2
100
3.5
FLUORESCENT & TUNGSTEN
40
PULLMAN
PUBLIC ADDRESS
RETRACTABLE SPINDLE (559X356 OVAL)

ALTERNATIVES

39
PUBLIC ADDRESS WITH TRANSMITTER

TRACTION DATA FOR MULTIPLE UNITS

BASIC TYPE

AJ 415 OA-REFURBISHED

VARIANTS

1A-REFURBISHED-TARE 39, PUBLIC ADDRESS WITH TRANSMITTER.

RESTAURANT KITCHEN BUFFET-MK I

CLASS ---

RKB

AK 502

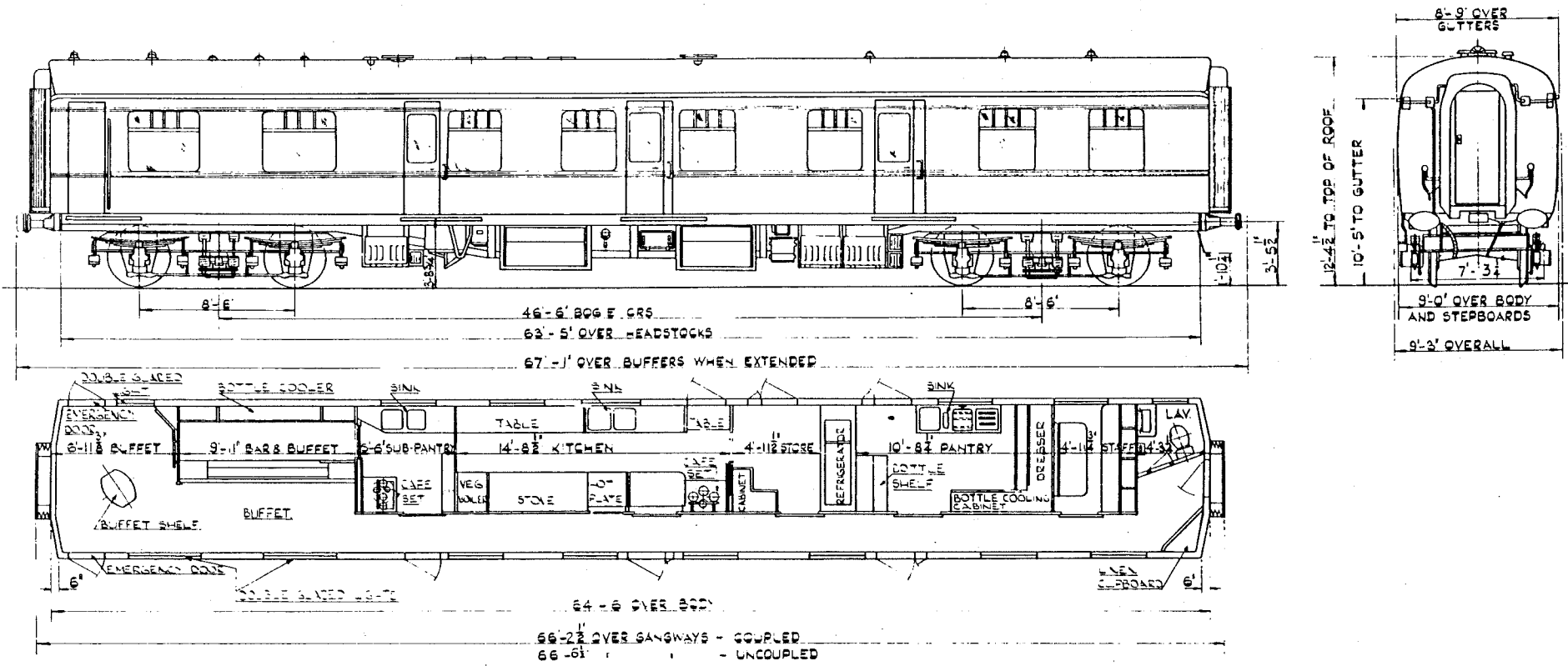

- SEATS -
- TOILETS - SEE VARIANTS
- COMPARTMENTS -
- GUARDS COMPARTMENTS -
- VENTILATION -
- CATERING EQUIPMENT - LIQUID GAS

ORIGINAL DIAGRAMS FOR REFERENCE:-
BR 25

ISSUE 1 DATE MAY 84

AK 502

BRAKES
 BOGIE/SUSPENSION
 BODY CONSTRUCTION
 COUPLINGS
 TRAIN HEATING
 E.T.H. INDEX
 MAX. SPEED M.P.H.
 MIN. RAD. CURVE CHAINS
 LIGHTING
 TARE WEIGHT TONNES
 GANGWAYS
 TRAIN COMMUNICATION
 BUFFERS
 TOILETS

BASIC TYPE

AIR
 B5
 STEEL
 AUTOMATIC DROPHEAD (BUCKEYE)
 DUAL (STEAM/ELECTRIC (BR))
 1 PLUS 600 AMP WIRING
 100
 3.5
 TUNGSTEN
 41
 PULLMAN
 PUBLIC ADDRESS
 RETRACTABLE SPINDLE (559X356 OVAL)
 1

ALTERNATIVES

VACUUM

 STEAM & THROUGH WIRED ONLY

 NOT FITTED

 NONE

TRACTION DATA FOR MULTIPLE UNITS

BASIC TYPE

AK 502 OA

VARIANTS

0B NO TOILET.
 1C STEAM HEATING & THROUGH WIRED ONLY, NO E.T.H., VACUUM BRAKES, NO TRAIN COMMUNICATION, NO TOILET.

RESTAURANT SECOND OPEN-MK I

CLASS ---

RSO

AM 201

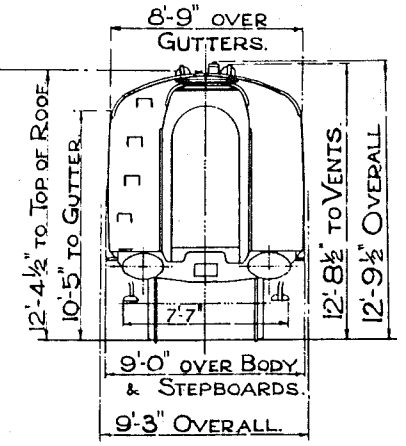
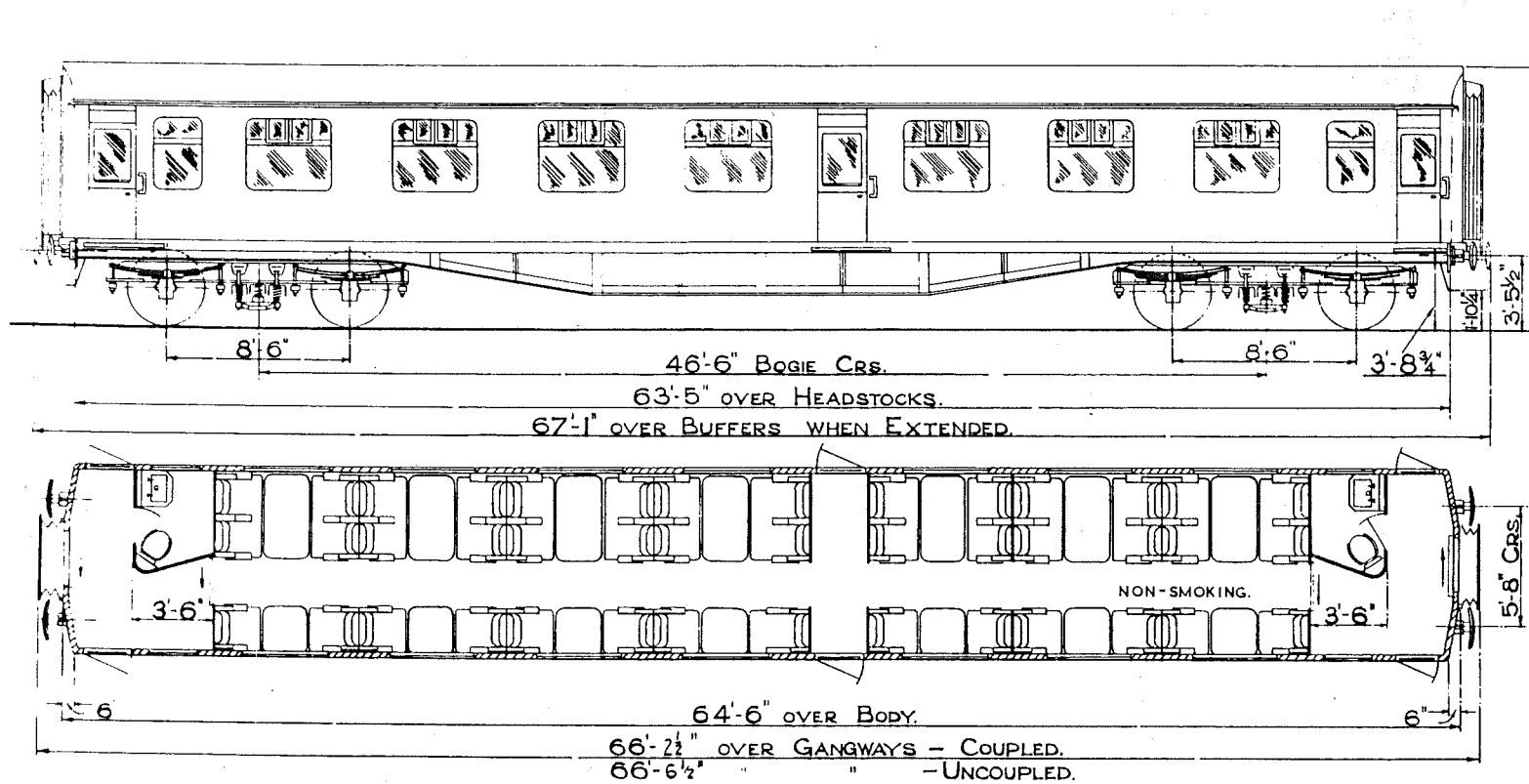

DOUBLE GLAZED LIGHTS FITTED IN VEHICLES BU TO LOT NUMBERS - 30648, 30697, 30717.

FLUORESCENT LIGHTING FITTED IN VEHICLES BU TO LOT NUMBERS - 30697, 30717.

INTERMEDIATE DOOR FITTED ONLY IN VEHICLES TO LOT NUMBERS - 30648, 30697, 30717.

SEATS	42
TOWLETS	2
COMPARTMENTS	-
GUARDS COMPARTMENTS	-
VENTILATION	-
CATERING EQUIPMENT	-

ORIGINAL DIAGRAMS FOR REFERENCE.-
BR 73

ISSUE 2 DATE MAY '81

AM 201

BASIC TYPE

ALTERNATIVES

BRAKES
BOGIE/SUSPENSION
BODY CONSTRUCTION
COUPLINGS
TRAIN HEATING
E.T.H. INDEX
MAX. SPEED M.P.H.
MIN. RAD. CURVE CHAINS
LIGHTING
TARE WEIGHT TONNES
GANGWAYS
TRAIN COMMUNICATION
BUFFERS

AIR
COMMONWEALTH
STEEL
AUTOMATIC DROPHEAD (BUCKEYE)
DUAL (STEAM/ELECTRIC (BR))
3
100
3.5
FLUORESCENT & TUNGSTEN
35
PULLMAN
NOT FITTED
RETRACTABLE SPINDLE (559X356 OVAL)

PUBLIC ADDRESS

TRACTION DATA FOR MULTIPLE UNITS

BASIC TYPE

AM 201 0A

VARIANTS

1A PUBLIC ADDRESS

SLEEPER LOUNGE FIRST (PROTOTYPE) MK 11f

CLASS ---

RL 6

AN 101

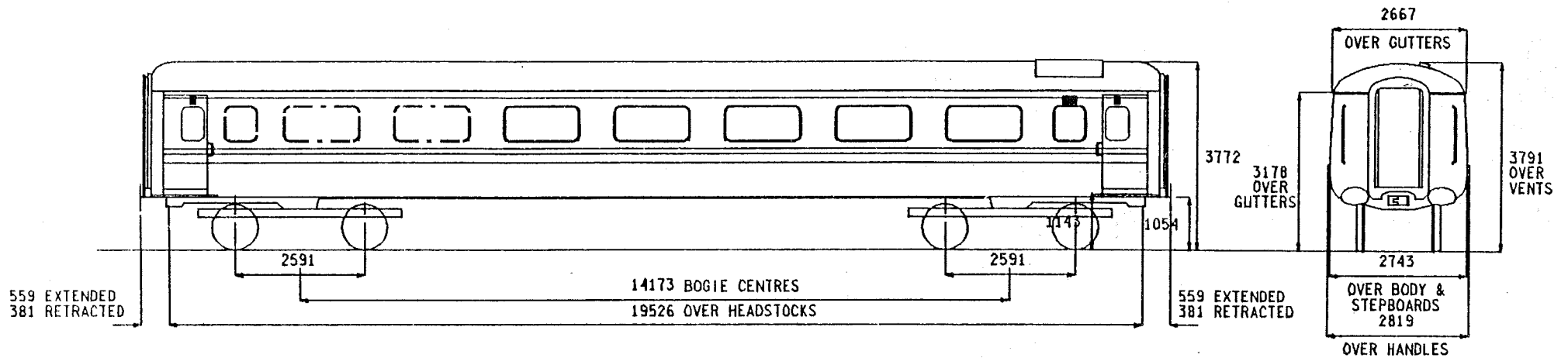

20377 OVER GANGWAYS-COUPLED
20453 OVER GANGWAYS-UNCOUPLED
20117 OVER BODY

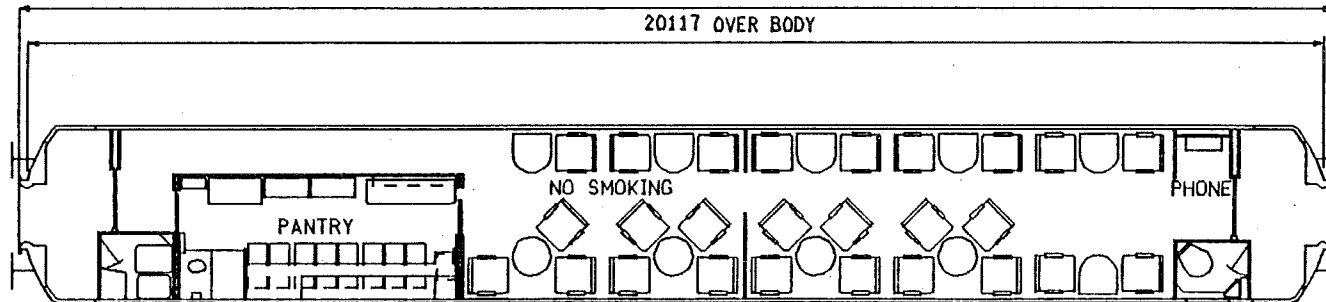

- | | |
|---------------------|-----------------------|
| SEATS | 26 |
| TOILETS | 1 |
| COMPARTMENTS | - |
| GUARDS COMPARTMENTS | - |
| VENTILATION | FULL AIR CONDITIONING |
| CATERING EQUIPMENT | MODULAR |

ISSUE 1
DATE APR 87

AN 101

BRAKES
BOGIE/SUSPENSION
BODY CONSTRUCTION
COUPLINGS
TRAIN HEATING
E.T.H. INDEX
MAX. SPEED M.P.H.
MIN. RAD. CURVE CHAINS
LIGHTING
TARE WEIGHT TONNES
GANGWAYS
TRAIN COMMUNICATION
BUFFERS

BASIC TYPE

AIR
B4
STEEL
AUTOMATIC DROPHEAD (BUCKEYE)
ELECTRIC (BR) FULL AIR CONDITIONING
5 PLUS 600 AMP WIRING.
100
3.5
HALOGEN SPOT LAMPS PLUS FLUORESCENT & TUNGSTEN
35 (EST)
PULLMAN
PUBLIC ADDRESS WITH TRANSMITTER
RETRACTABLE SPINDLE (559X356 OVAL)

ALTERNATIVES

TRACTION DATA FOR MULTIPLE UNITS

BASIC TYPE

AN 101 OA

VARIANTS

NONE

REFRESHMENT LOUNGE FIRST (PROTOTYPE) MK 11f

CLASS ---

RLO

AN 101

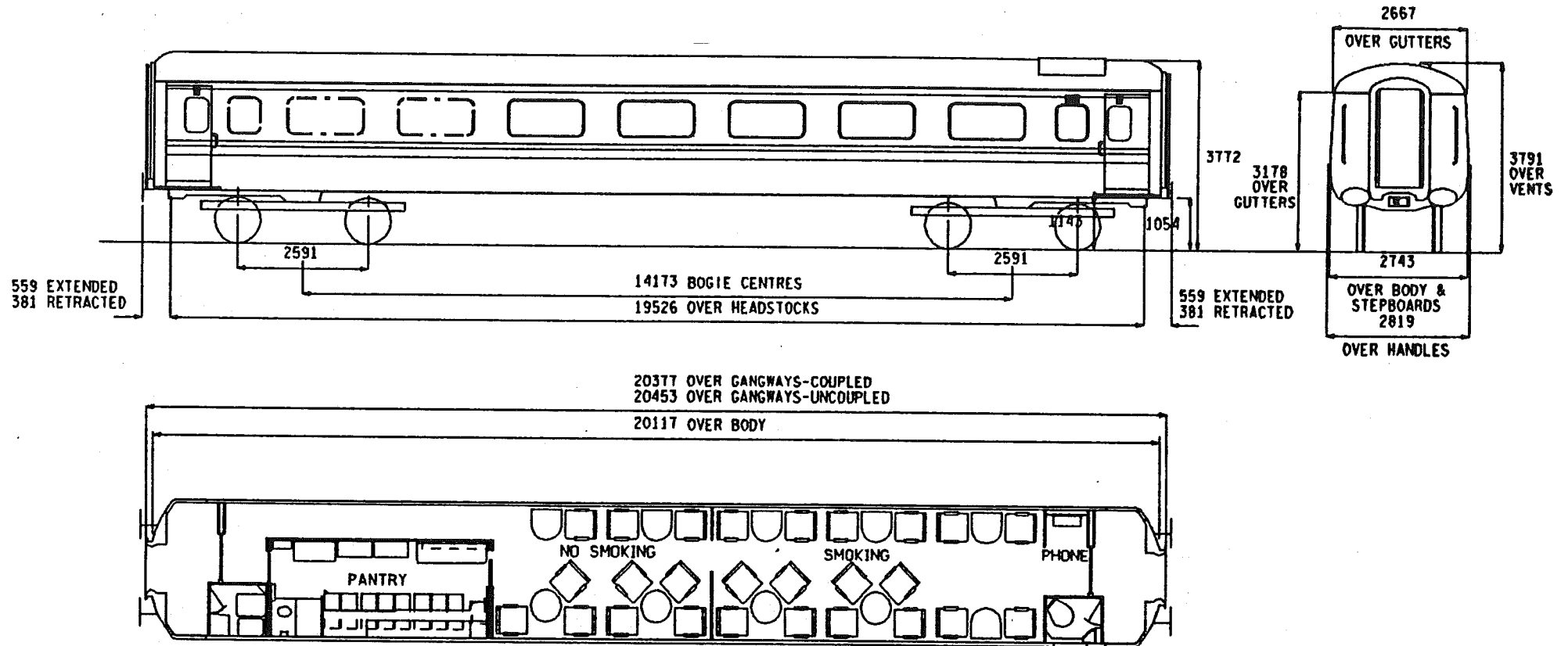

- | | |
|---------------------|-----------------------|
| SEATS (LOOSE) | 26 |
| TOILETS | 1 |
| COMPARTMENTS | - |
| GUARDS COMPARTMENTS | - |
| VENTILATION | FULL AIR CONDITIONING |
| CATERING EQUIPMENT | MODULAR |

ISSUE 2 DATE MAR 89

AN 101

**BRAKES
BOGIE/SUSPENSION
BODY CONSTRUCTION
COUPLINGS
TRAIN HEATING
E.T.H. INDEX
MAX.SPEED M.P.H.
MIN.RAD.CURVE CHAINS
LIGHTING
TARE WEIGHT TONNES
GANGWAYS
TRAIN COMMUNICATION
BUFFERS**

BASIC TYPE

**AIR
B4
STEEL
AUTOMATIC DROPHEAD(BUCKEYE)
ELECTRIC(BR)FULL AIR CONDITIONING
5 PLUS 600 AMP WIRING
100
3.5
HALOGEN SPOT LAMPS PLUS FLUORESCENT & TUNGSTEN
35(EST)
PULLMAN
PUBLIC ADDRESS WITH TRANSMITTER
RETRACTABLE SPINDLE(559X356 OVAL)**

ALTERNATIVES

TRACTION DATA FOR MULTIPLE UNITS

BASIC TYPE

AN 101 OA

VARIANTS

NONE

REFRESHMENT LOUNGE FIRST - MK 11f

CLASS ---

RLO

AN 102

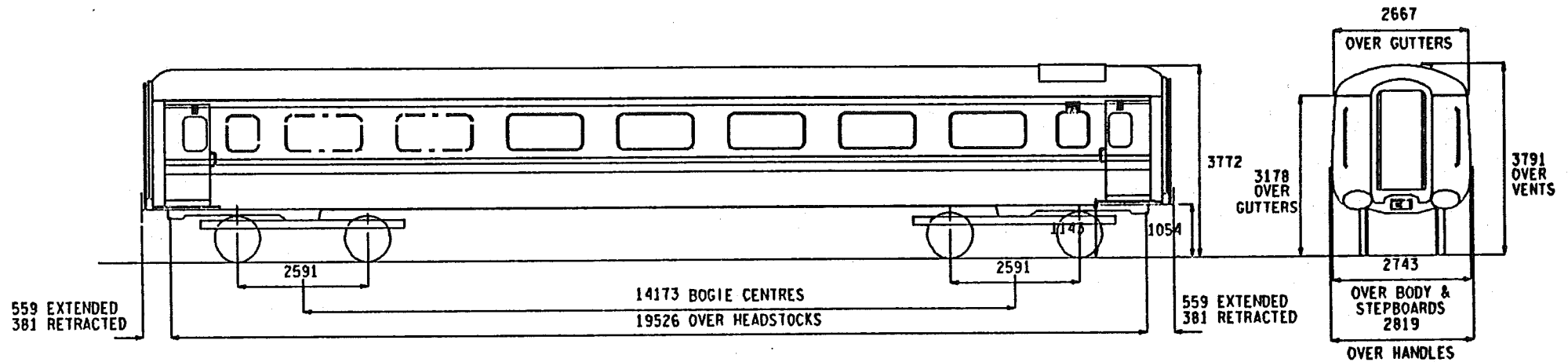

20377 OVER GANGWAYS-COUPLED
20453 OVER GANGWAYS-UNCOUPLED
20117 OVER BODY

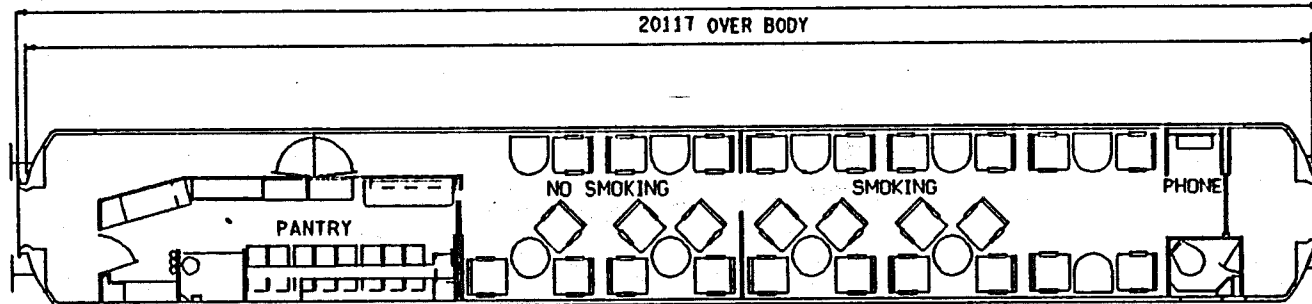

- | | |
|---------------------|-----------------------|
| SEATS (LOOSE) | 26 |
| TOILETS | 1 |
| COMPARTMENTS | - |
| GUARDS COMPARTMENTS | - |
| VENTILATION | FULL AIR CONDITIONING |
| CATERING EQUIPMENT | MODULAR |

ISSUE 1 DATE MAR 89

AN 102

BRAKES
 BOGIE/SUSPENSION
 BODY CONSTRUCTION
 COUPLINGS
 TRAIN HEATING
 E.T.H. INDEX
 MAX. SPEED M.P.H.
 MIN. RAD. CURVE CHAINS
 LIGHTING
 TARE WEIGHT TONNES
 GANGWAYS
 TRAIN COMMUNICATION
 BUFFERS

BASIC TYPE

AIR
 B4
 STEEL
 AUTOMATIC DROPHEAD(BUCKEYE)
 ELECTRIC(BR)FULL AIR CONDITIONING
 6
 100
 3.5
 HALOGEN SPOT LAMPS PLUS FLUORESCENT & TUNGSTEN
 35(EST)
 PULLMAN
 PUBLIC ADDRESS WITH TRANSMITTER
 RETRACTABLE SPINDLE(559X356 OVAL)

ALTERNATIVES

TRACTION DATA FOR MULTIPLE UNITS

BASIC TYPE

AN 102 OA

VARIANTS

NONE

RESTAURANT MINIATURE BUFFET-MK 1

CLASS ---

RMB

AN 202

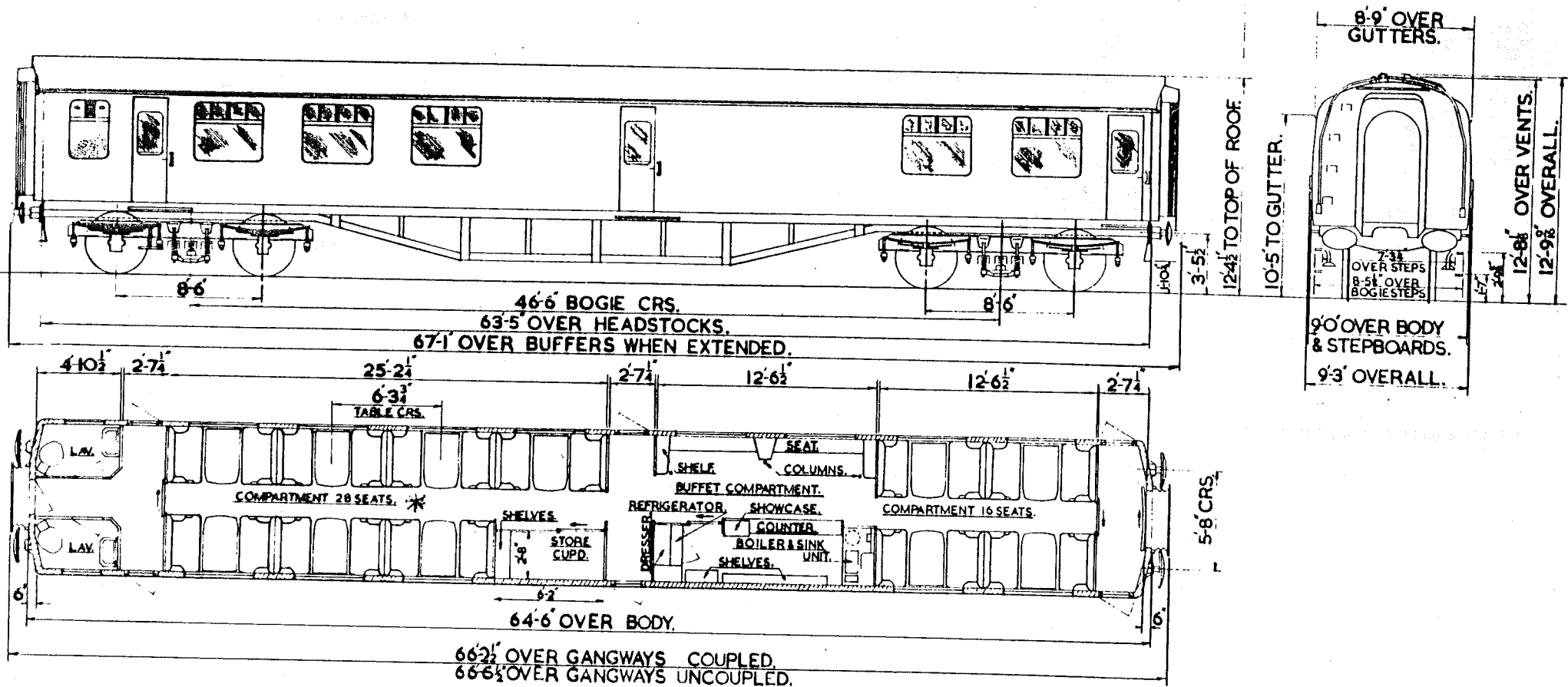

* THIS AREA NON SMOKING ON SOME VEHICLES. SEE VARIANTS

DOUBLE GLAZED THROUGHOUT EXCEPT FOR LIGHTS IN TOILETS.

SEATS	44
TOILETS	2
COMPARTMENTS	-
GUARDS COMPARTMENTS	-
VENTILATION	-
CATERING EQUIPMENT	LIQUID GAS

ORIGINAL DIAGRAMS FOR REFERENCE:-
BR 98

ISSUE 5 DATE OCT 86

AN 202

BRAKES
 BOGIE/SUSPENSION
 BODY CONSTRUCTION
 COUPLINGS
 TRAIN HEATING
 E.T.H. INDEX
 MAX. SPEED M.P.H.
 MIN. RAD. CURVE CHAINS
 LIGHTING
 TARE WEIGHT TONNES
 GANGWAYS
 TRAIN COMMUNICATION
 BUFFERS
 SMOKING ACCOMMODATION

BASIC TYPE

VACUUM
 B5
 STEEL
 AUTOMATIC DROPHEAD (BUCKEYE)
 STEAM
 -
 100
 3.5
 TUNGSTEN
 38
 PULLMAN
 NOT FITTED
 RETRACTABLE SPINDLE (559X356 OVAL)
 ALL SMOKING

ALTERNATIVES

AIR, VACUUM & AIR
 BR MK 1 LIGHT DOUBLE BOLSTER, COMMONWEALTH, B4

DUAL (STEAM/ELECTRIC (BR)), ELECTRIC (BR)
 3,3 WITH 675 VOLT HEATERS
 90

FLUORESCENT & TUNGSTEN

PUBLIC ADDRESS

66% NON SMOKING

TRACTION DATA FOR MULTIPLE UNITSBASIC TYPE

AN 202 OA

VARIANTS

0C BR MK 1 LIGHT DOUBLE BOLSTER BOGIES, MAX. SPEED 90.
 2G ELECTRIC (BR) HEATING, AIR BRAKES, E.T.H. 3 WITH 675 VOLT HEATERS, B4 BOGIES, MAX. SPEED 90.
 3D REFURBISHED-DUAL HEATING (STEAM/ELECTRIC (BR)), E.T.H. 3, FLUORESCENT & TUNGSTEN LIGHTING.
 3E REFURBISHED-DUAL HEATING (STEAM/ELECTRIC (BR)), E.T.H. 3, COMMONWEALTH BOGIES, FLUORESCENT & TUNGSTEN LIGHTING.
 3H REFURBISHED-DUAL HEATING (STEAM/ELECTRIC (BR)), VACUUM & AIR BRAKES, E.T.H. 3, COMMONWEALTH BOGIES, FLUORESCENT & TUNGSTEN LIGHTING, L.H. END NON SMOKING.
 4H REFURBISHED-DUAL HEATING (STEAM/ELECTRIC (BR)), VACUUM & AIR BRAKES, E.T.H. 3, COMMONWEALTH BOGIES, FLUORESCENT & TUNGSTEN LIGHTING, PUBLIC ADDRESS.

RESTAURANT MINIATURE BUFFET-MK 1

CLASS ---

RMB

AN 203

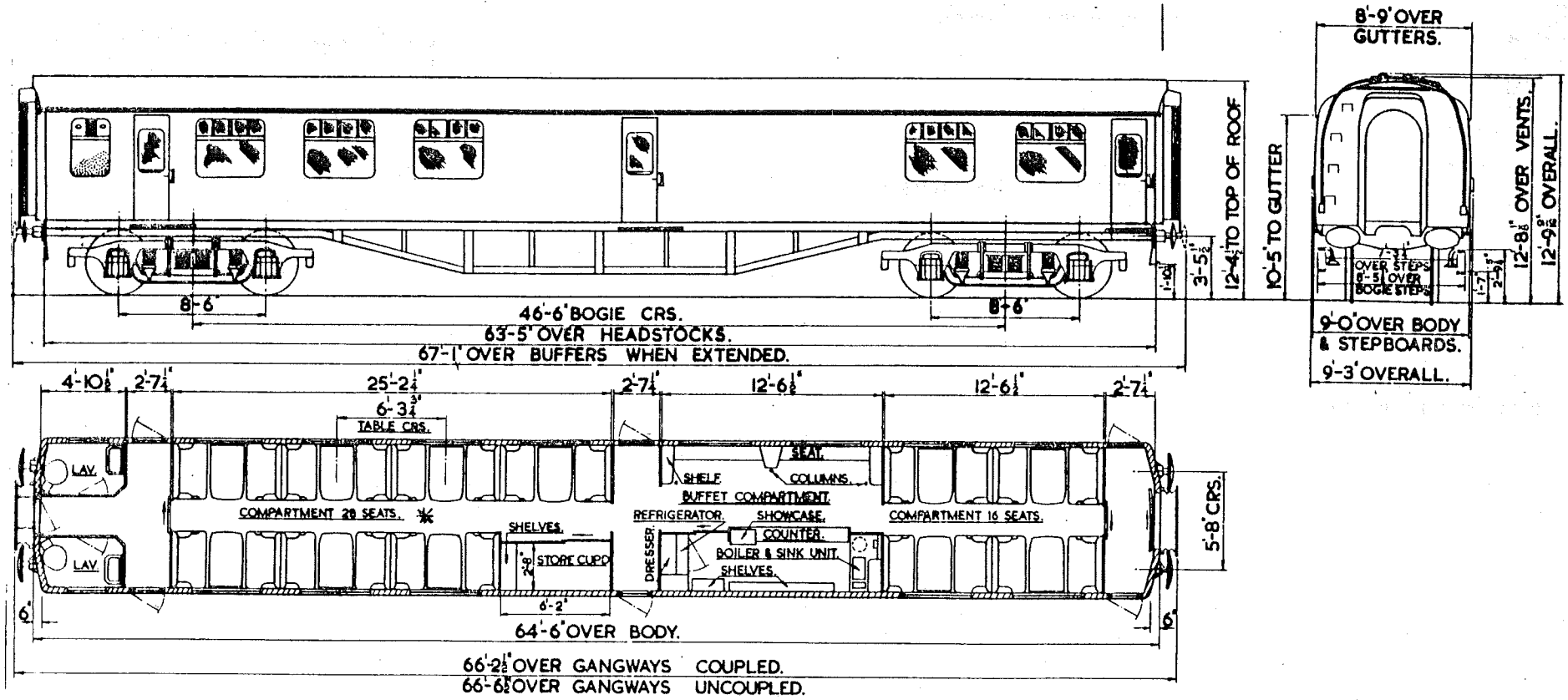

* NON SMOKING ON SOME VEHICLES

DOUBLE GLAZED THROUGHOUT EXCEPT FOR LIGHTS IN TOILETS.

SEATS	44
TOILETS	2
COMPARTMENTS	-
GUARDS COMPARTMENTS	-
VENTILATION	-
CATERING EQUIPMENT	LIQUID GAS

ORIGINAL DIAGRAMS FOR REFERENCE:- BR 99

ISSUE 6 DATE OCT 86

AN 203

BRAKES
 BOGIE/SUSPENSION
 BODY CONSTRUCTION
 COUPLINGS
 TRAIN HEATING
 E.T.H. INDEX
 MAX. SPEED M.P.H.
 MIN. RAD. CURVE CHAINS
 LIGHTING
 TARE WEIGHT TONNES
 GANGWAYS
 TRAIN COMMUNICATION
 BUFFERS
 SMOKING ACCOMMODATION

BASIC TYPE

VACUUM
 COMMONWEALTH
 STEEL
 AUTOMATIC DROPHEAD (BUCKEYE)
 STEAM
 -
 100
 3.5
 TUNGSTEN
 38
 PULLMAN
 NOT FITTED
 RETRACTABLE SPINDLE (559X356 OVAL)
 ALL SMOKING

ALTERNATIVES

AIR, VACUUM & AIR
 BR MK 1 LIGHT DOUBLE BOLSTER, B4

DUAL (STEAM/ELECTRIC (BR)), ELECTRIC (BR)
 3,3 WITH 675 VOLT HEATERS, 3 PLUS 600 AMP WIRING
 90

FLUORESCENT & TUNGSTEN

PUBLIC ADDRESS

L.H. END NON SMOKING

TRACTION DATA FOR MULTIPLE UNITSBASIC TYPE

AN 203 OA

VARIANTS

1M DUAL HEATING (STEAM/ELECTRIC (BR)), E.T.H.3, VACUUM & AIR BRAKES.
 2D ELECTRIC (BR) HEATING, AIR BRAKES, E.T.H.3 WITH 675 VOLT HEATERS, MAX. SPEED 90, L.H. END NON SMOKING
 3C BR MK 1 LIGHT DOUBLE BOLSTER BOGIES, E.T.H.3, MAX. SPEED 90.
 6E REFURBISHED-DUAL HEATING (STEAM/ELECTRIC (BR)), E.T.H.3, FLUORESCENT & TUNGSTEN LIGHTING.
 6F REFURBISHED-DUAL HEATING (STEAM/ELECTRIC (BR)), E.T.H.3, FLUORESCENT & TUNGSTEN LIGHTING, B4 BOGIES.
 6K REFURBISHED-DUAL HEATING (STEAM/ELECTRIC (BR)), AIR BRAKES, E.T.H.3, FLUORESCENT & TUNGSTEN LIGHTING, L.H. END NON SMOKING
 6L REFURBISHED-DUAL HEATING (STEAM/ELECTRIC (BR)), VACUUM & AIR BRAKES, E.T.H.3, FLUORESCENT & TUNGSTEN LIGHTING, L.H. END NON SMOKING
 7J REFURBISHED-DUAL HEATING (STEAM/ELECTRIC (BR)), AIR BRAKES, E.T.H.3, FLUORESCENT & TUNGSTEN LIGHTING, PUBLIC ADDRESS, B4 BOGIES.
 7K REFURBISHED-DUAL HEATING (STEAM/ELECTRIC (BR)), AIR BRAKES, E.T.H.3, FLUORESCENT & TUNGSTEN LIGHTING, PUBLIC ADDRESS, L.H. END NON SMOKING
 7L REFURBISHED-DUAL HEATING (STEAM/ELECTRIC (BR)), VACUUM & AIR BRAKES, E.T.H.3, FLUORESCENT & TUNGSTEN LIGHTING, PUBLIC ADDRESS.
 8K REFURBISHED-DUAL HEATING (STEAM/ELECTRIC (BR)), AIR BRAKES, E.T.H.3 PLUS 600 AMP WIRING, FLUORESCENT & TUNGSTEN LIGHTING, L.H. END NON SMOKING
 8L REFURBISHED-DUAL HEATING (STEAM/ELECTRIC (BR)), VACUUM & AIR BRAKES, E.T.H.3 PLUS 600 AMP WIRING, FLUORESCENT & TUNGSTEN LIGHTING, L.H. END NON SMOKING
 9I REFURBISHED-DUAL HEATING (STEAM/ELECTRIC (BR)), VACUUM & AIR BRAKES, E.T.H.3 PLUS 600 AMP WIRING, FLUORESCENT & TUNGSTEN LIGHTING, PUBLIC ADDRESS

SECOND OPEN WITH MINIATURE BUFFET-MK I D

CLASS ---

RMBT

AN 207

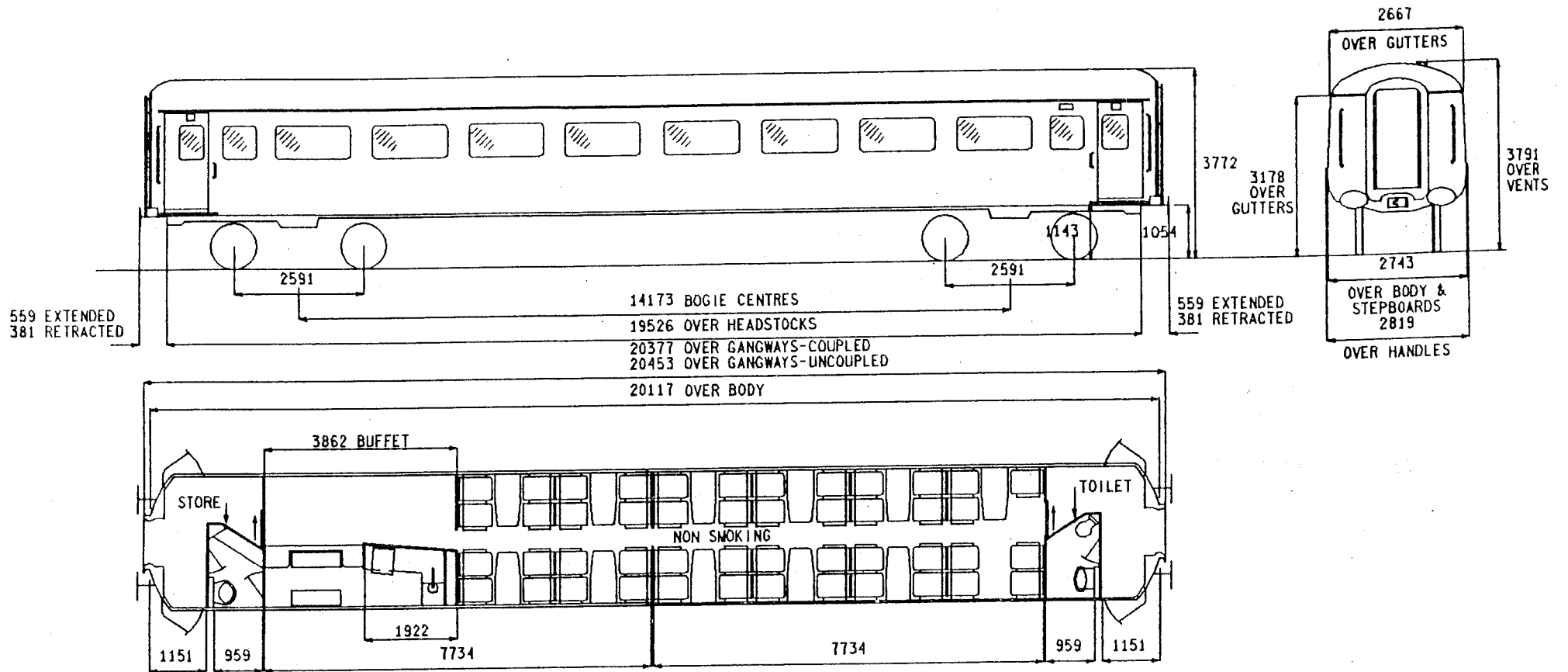

- SEATS 47
- TOILETS 1
- COMPARTMENTS -
- GUARDS COMPARTMENTS -
- VENTILATION FULL AIR CONDITIONING
- CATERING EQUIPMENT -

ISSUE 1 DATE MAR 86

AN 207

BRAKES
 BOGIE/SUSPENSION
 BODY CONSTRUCTION
 COUPLINGS
 TRAIN HEATING
 E.T.H. INDEX
 MAX. SPEED M.P.H.
 MIN. RAD. CURVE CHAINS
 LIGHTING
 TARE WEIGHT TONNES
 GANGWAYS
 TRAIN COMMUNICATION
 BUFFERS

BASIC TYPE

AIR
 B4
 STEEL
 AUTOMATIC DROPHEAD(BUCKEYE)
 ELECTRIC(BR)FULL AIR CONDITIONING
 6
 100
 3.5
 FLUORESCENT & TUNGSTEN
 33.5
 PULLMAN
 PUBLIC ADDRESS WITH TRANSMITTER
 RETRACTABLE SPINDLE(559X356 OVAL)

ALTERNATIVES

TRACTION DATA FOR MULTIPLE UNITS

BASIC TYPE

AN 207 OA

VARIANTS

NONE

RESTAURANT MINIATURE BUFFET - MK 1

CLASS ---

RMB

AN 208

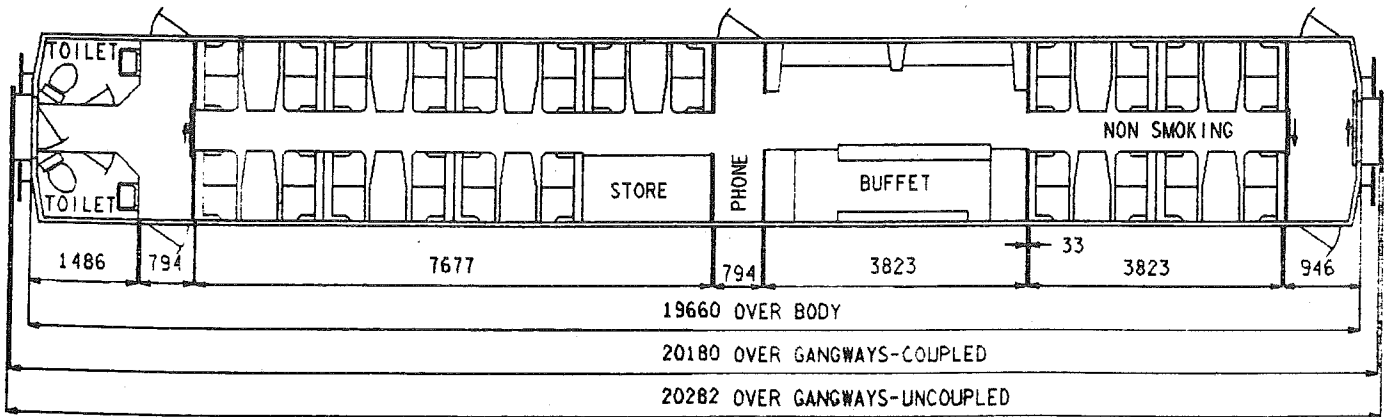
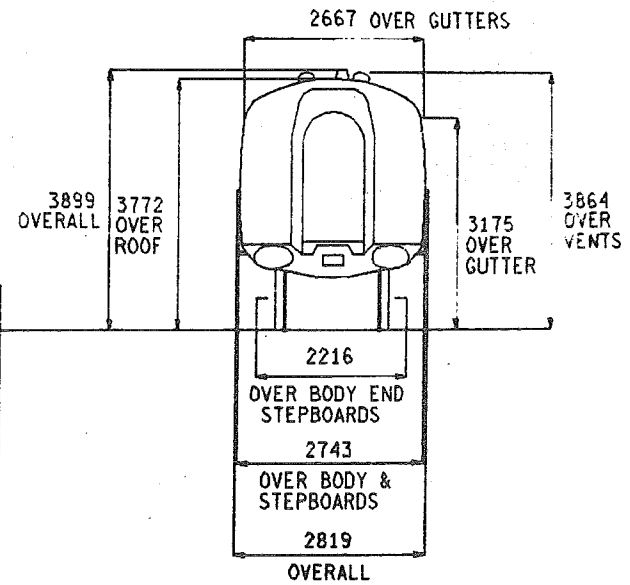
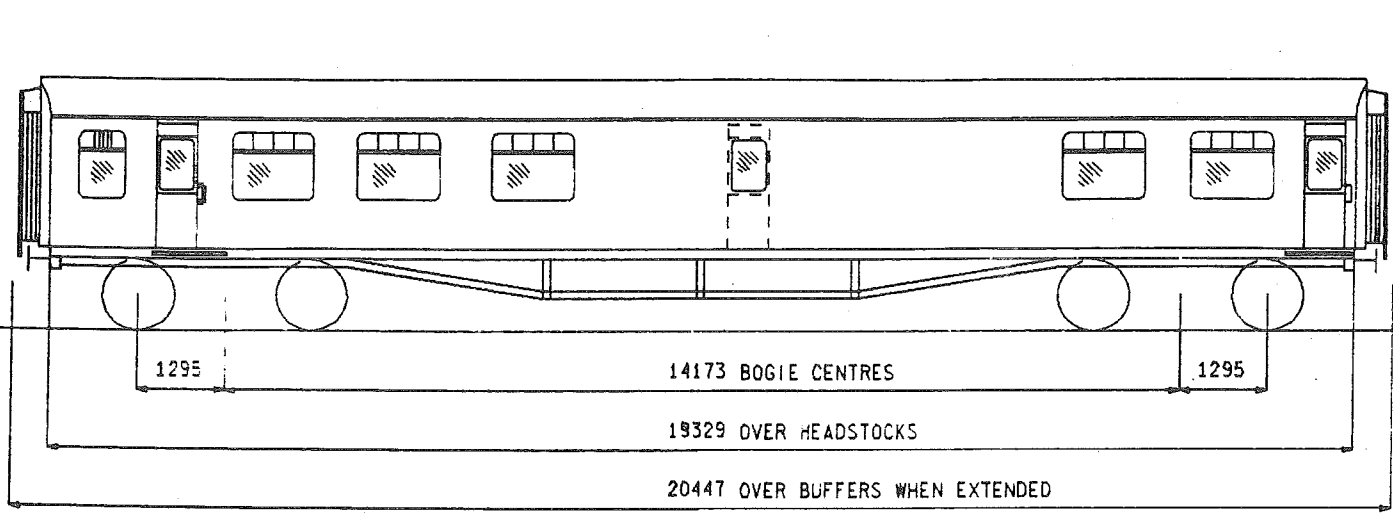

SEATS	44
TOILETS	2
COMPARTMENTS	-
GUARDS COMPARTMENTS	-
VENTILATION	-
CATERING EQUIPMENT	ELECTRIC - MICROWAVE

ISSUE 2 DATE AUG 88

AN 208

BRAKES
BOGIE/SUSPENSION
BODY CONSTRUCTION
COUPLINGS
TRAIN HEATING
E.T.H. INDEX
MAX. SPEED M.P.H.
MIN. RAD. CURVE CHAINS
LIGHTING
TARE WEIGHT TONNES
GANGWAYS
TRAIN COMMUNICATION
BUFFERS

BASIC TYPE

VACUUM & AIR
COMMONWEALTH
STEEL
AUTOMATIC DROPHEAD (BUCKEYE)
ELECTRIC (BR)
3
100
3.5
FLUORESCENT
38
PULLMAN
P.A. & TRANSMITTER
RETRACTABLE SPINDLE (559X356 OVAL)

ALTERNATIVES

VACUUM
B5

TRACTION DATA FOR MULTIPLE UNITS

BASIC TYPE

AN 208 OA FACELIFTED 1988

VARIANTS

OB FACELIFTED 1988, VACUUM BRAKES, B5 BOGIES

PULLMAN FIRST WITH KITCHEN

CLASS ---

PFK

AP 101

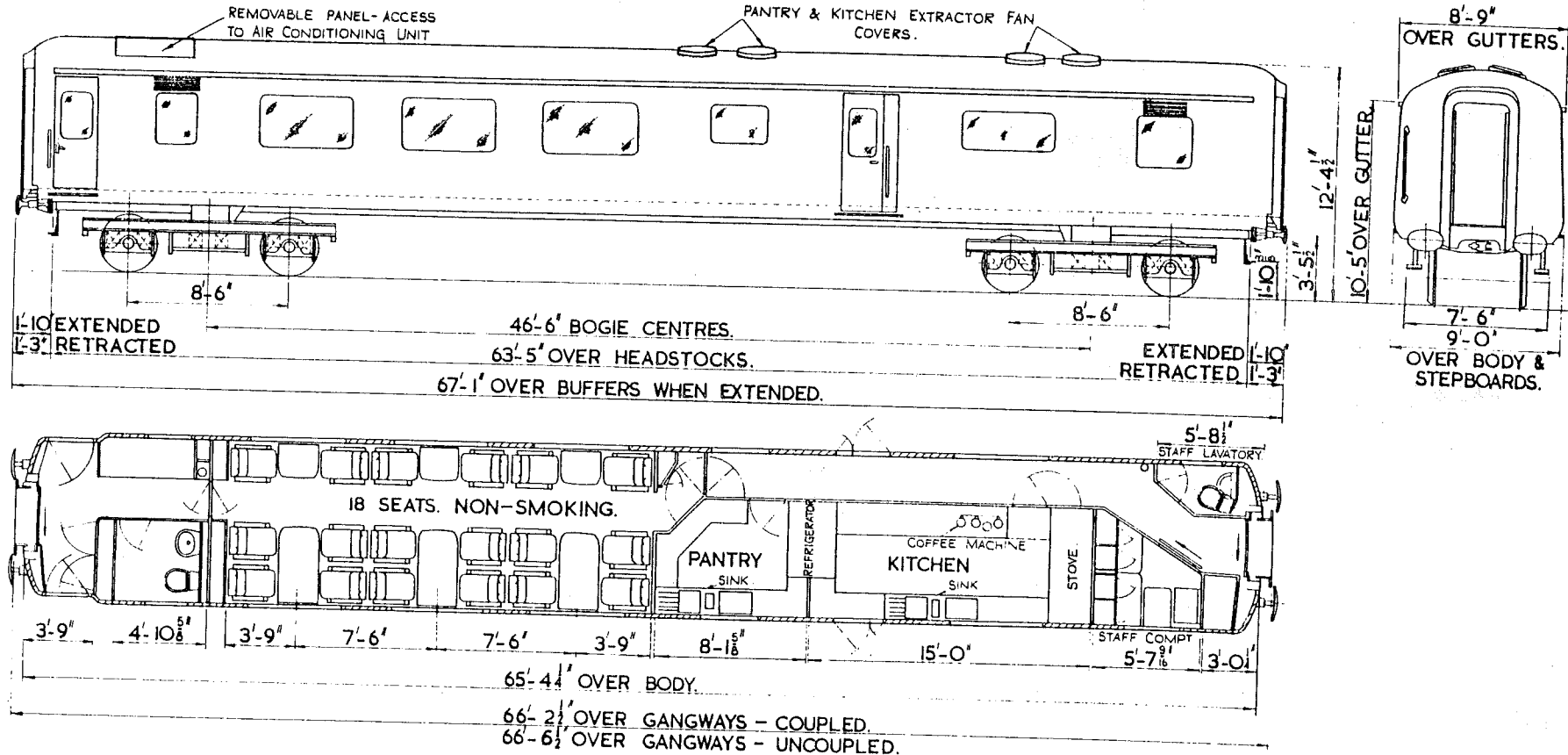

DOUBLE GLAZED THROUGHOUT.

SEATS	18
TOILETS	2
COMPARTMENTS	-
GUARDS COMPARTMENTS	-
VENTILATION	PRESSURE
CATERING EQUIPMENT	LIQUID GAS-ELECTRIC BOILER

ORIGINAL DIAGRAMS FOR REFERENCE:-
BR 15

ISSUE 2 DATE OCT '86

AP 101

BRAKES
BOGIE/SUSPENSION
BODY CONSTRUCTION
COUPLINGS
TRAIN HEATING

E.T.H. INDEX
MAX. SPEED M.P.H.
MIN. RAD. CURVE CHAINS
LIGHTING
TARE WEIGHT TONNES
GANGWAYS
TRAIN COMMUNICATION
BUFFERS

BASIC TYPE

VACUUM
B5
STEEL
AUTOMATIC DROPHEAD(BUCKEYE)
ELECTRIC(BR)WITH PRESSURE VENTILATION & HEATING-SUITED TO A.C.
ELECTRIC LOCOS ONLY
6
100
3.5
FLUORESCENT & TUNGSTEN
41
PULLMAN
NOT FITTED
RETRACTABLE SPINDLE(559X356 OVAL)

ALTERNATIVES

VACUUM & AIR

TRACTION DATA FOR MULTIPLE UNITS

BASIC TYPE

AP 101 OA

VARIANTS

OB VACUUM & AIR BRAKED

PULLMAN FIRST PARLOUR

CLASS ---

PFP

AQ 101

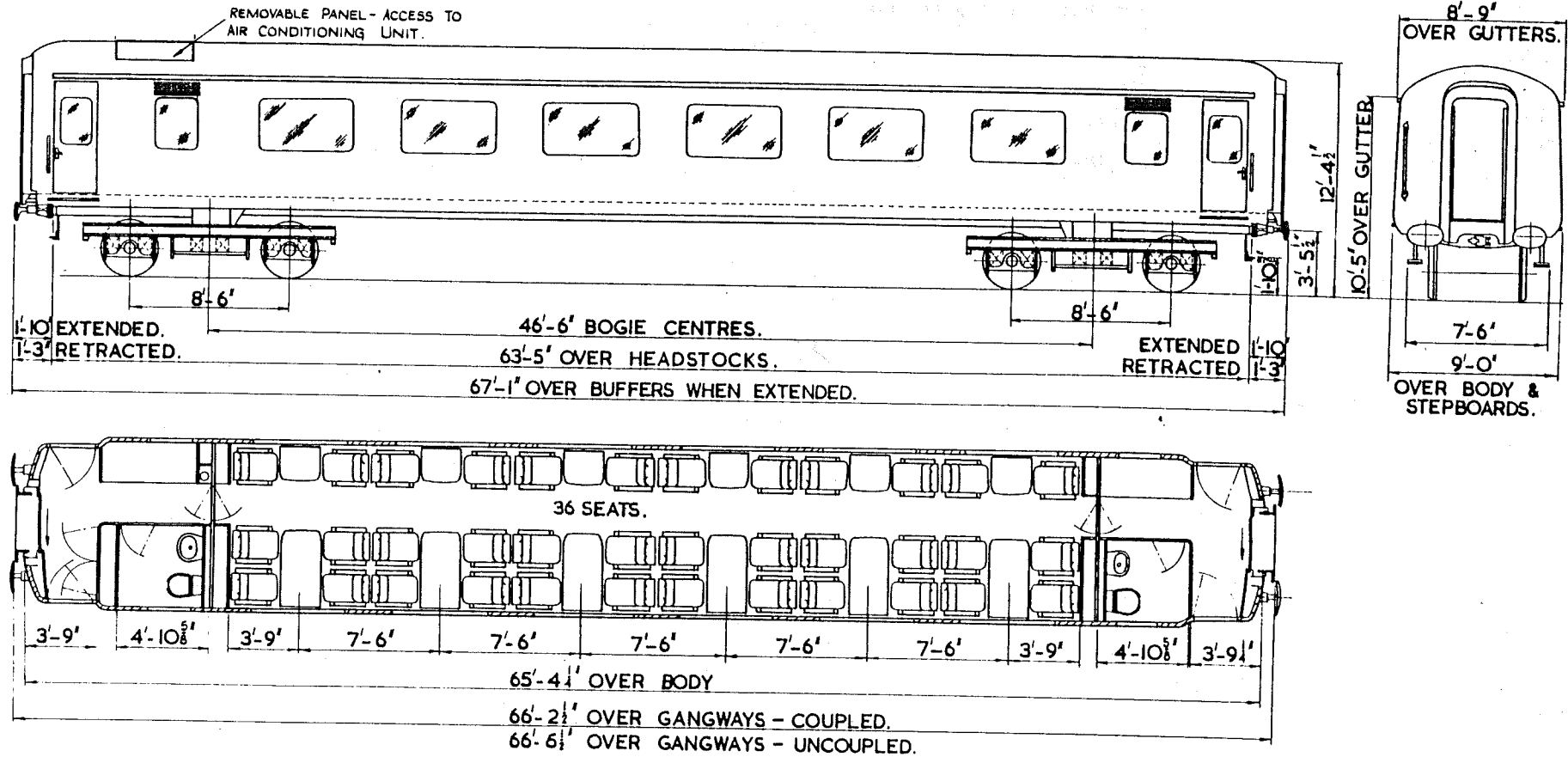

SEATS	36
TOILETS	2
COMPARTMENTS	-
GUARDS COMPARTMENTS	-
VENTILATION	PRESSURE
CATERING EQUIPMENT	-

ORIGINAL DIAGRAMS FOR REFERENCE:-
BR 78

ISSUE 2 DATE OCT '86

AQ 101

BRAKES
BOGIE/SUSPENSION
BODY CONSTRUCTION
COUPLINGS
TRAIN HEATING

E.T.H. INDEX
MAX. SPEED M.P.H.
MIN. RAD. CURVE CHAINS
LIGHTING
TARE WEIGHT TONNES
GANGWAYS
TRAIN COMMUNICATION
BUFFERS

BASIC TYPE

VACUUM
B4
STEEL
AUTOMATIC DROPHEAD(BUCKEYE)
ELECTRIC(BR)WITH PRESSURE VENTILATION & HEATING(SUITED TO A.C.
ELECTRIC LOCOS ONLY)
5
100
3.5
FLUORESCENT & TUNGSTEN
35
PULLMAN
NOT FITTED
RETRACTABLE SPINDLE(559X356 OVAL)

ALTERNATIVES

VACUUM & AIR

TRACTION DATA FOR MULTIPLE UNITS

BASIC TYPE

AQ 101 OA

VARIANTS

OB VACUUM & AIR BRAKED

PULLMAN FIRST BRAKE

CLASS ---

PFB

AR 101

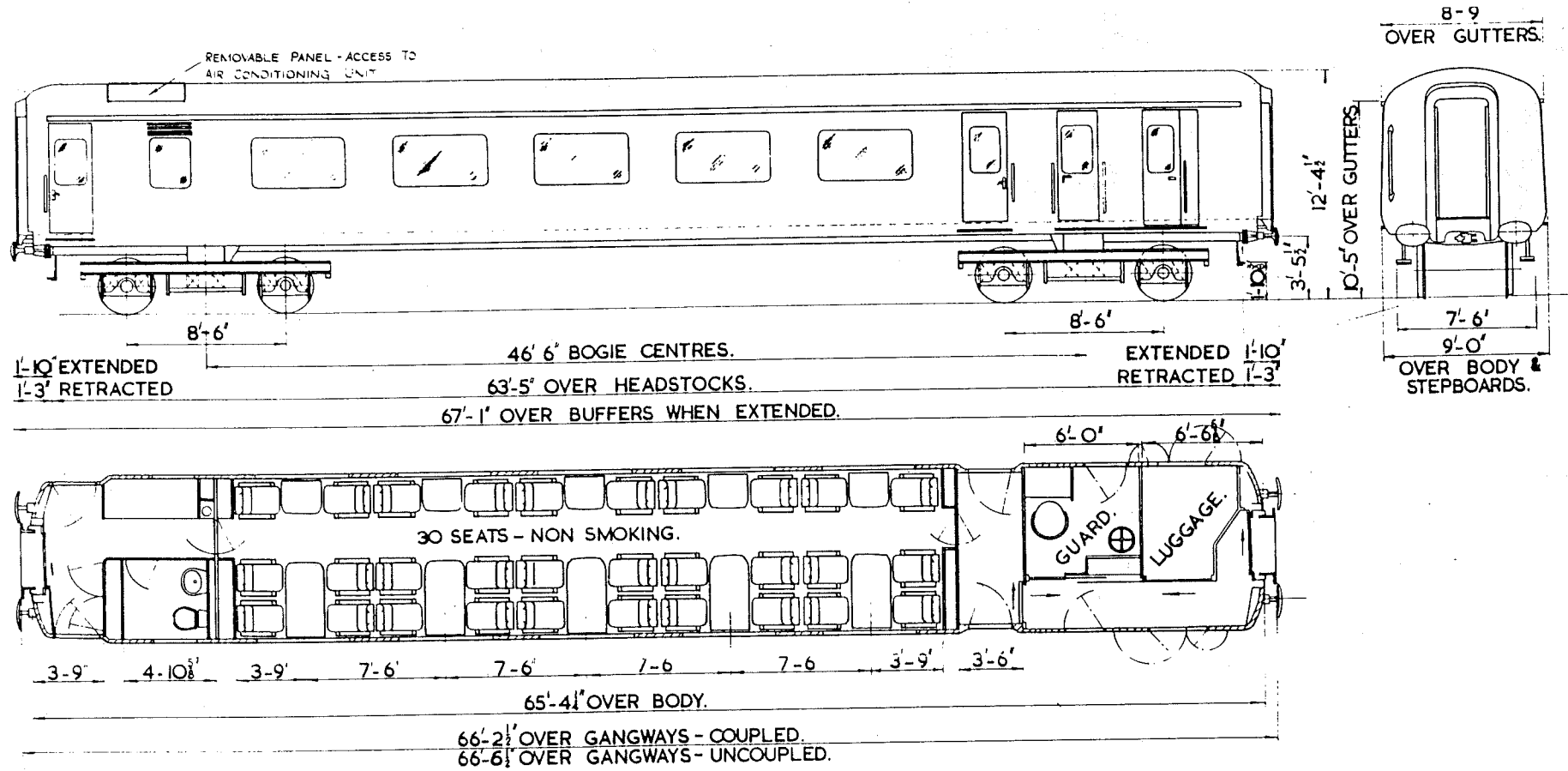

SEATS	30
TOILETS	1
COMPARTMENTS	-
GUARDS COMPARTMENTS	1
VENTILATION	PRESSURE
CATERING EQUIPMENT	-

ORIGINAL DIAGRAMS FOR REFERENCE.-
BR 85

ISSUE 1 DATE SEP' 80

AR 101

BRAKES
BOGIE/SUSPENSION
BODY CONSTRUCTION
COUPLINGS
TRAIN HEATING

E.T.H. INDEX
MAX. SPEED
MIN. RAD. CURVE CHAINS
LIGHTING
TARE WEIGHT TONNES
GANGWAYS
TRAIN COMMUNICATION
BUFFERS

BASIC TYPE

VACUUM
B4
STEEL
AUTOMATIC DROPHEAD (BUCKEYE)
ELECTRIC (BR) WITH PRESSURE VENTILATION & HEATING (SUITED TO A.C.
ELECTRIC LOCOS ONLY)
4
100
3.5
FLUORESCENT & TUNGSTEN
35
PULLMAN
NOT FITTED
RETRACTABLE SPINDLE (559X356 OVAL)

ALTERNATIVES

TRACTION DATA FOR MULTIPLE UNITS

BASIC TYPE

AR 101 OA

VARIANTS

NONE

SLEEPING FIRST-MK I

CLASS ----

SLF

AS 101

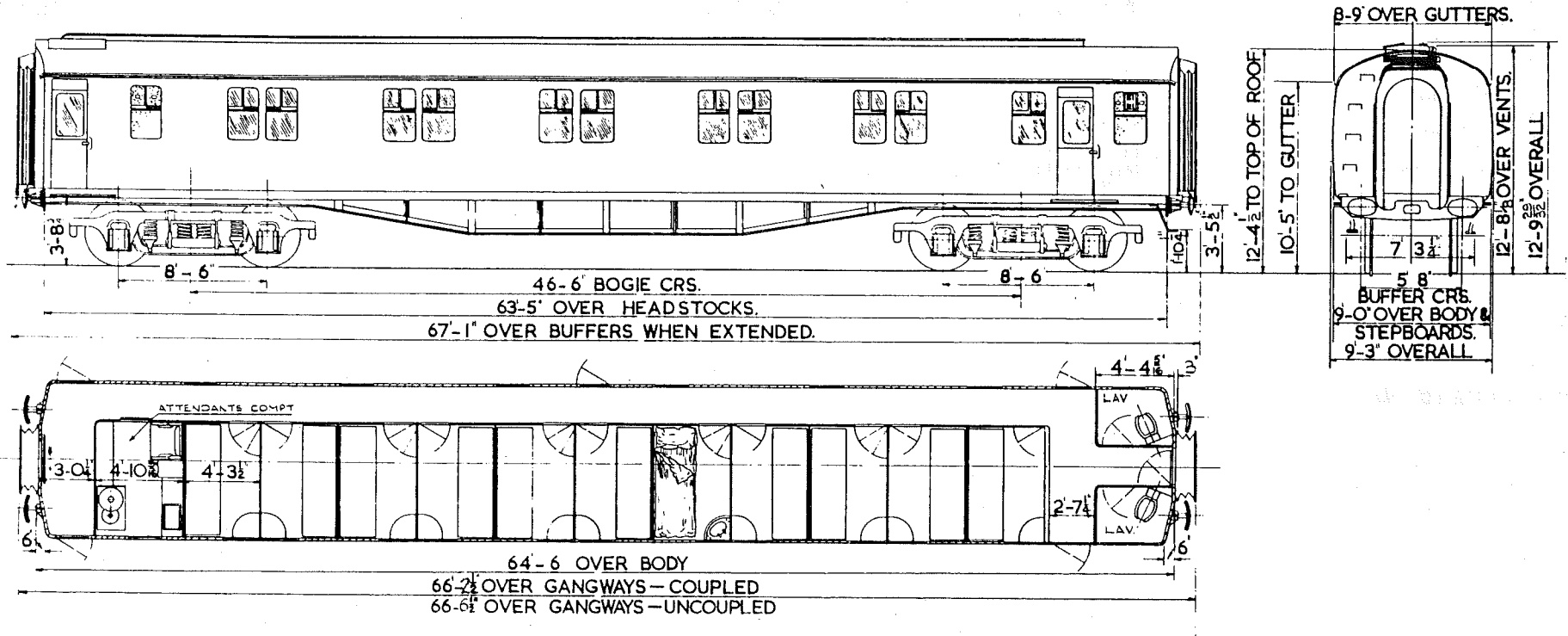

- | | |
|---------------------|------------|
| SEATS | 11 BERTHS |
| TOILETS | 2 |
| COMPARTMENTS | 11 |
| GUARDS COMPARTMENTS | - |
| VENTILATION | PRESSURE |
| CATERING EQUIPMENT | LIQUID GAS |

ORIGINAL DIAGRAMS FOR REFERENCE.-
BR 1

ISSUE 1 DATE SEP '80

AS 101

	<u>BASIC TYPE</u>	<u>ALTERNATIVES</u>
BRAKES	VACUUM	B5
BOGIE/SUSPENSION	COMMONWEALTH	
BODY CONSTRUCTION	STEEL	
COUPLINGS	AUTOMATIC DROPHEAD (BUCKEYE)	DUAL (STEAM/ELECTRIC (BR)) WITH PRESSURE VENTILATION & HEATING
TRAIN HEATING	STEAM WITH PRESSURE VENTILATION AND HEATING	3,3 PLUS 600 AMP WIRING
E.T.H. INDEX	-	
MAX. SPEED M.P.H.	100	
MIN. RAD. CURVE, CHAINS	3.5	
LIGHTING	ELECTRIC	40
TARE WEIGHT, TONNES	41	
GANGWAYS	PULLMAN	
TRAIN COMMUNICATION	NOT FITTED	
BUFFERS	RETRACTABLE SPINDLE (559X356 OVAL)	

TRACTION DATA FOR MULTIPLE UNITSBASIC TYPE

AS 101 0A

VARIANTS

- 0B B5 BOGIES
- 1A DUAL (STEAM/ELECTRIC (BR)) WITH PRESSURE VENTILATION & HEATING, TARE 40, E.T.H. 3.
- 1C DUAL (STEAM/ELECTRIC (BR)) WITH PRESSURE VENTILATION & HEATING, TARE 40, E.T.H. 3, B5 BOGIES.
- 2A DUAL (STEAM/ELECTRIC (BR)) WITH PRESSURE VENTILATION & HEATING, TARE 40, E.T.H. 3 PLUS 600 AMP WIRING.
- 2B DUAL (STEAM/ELECTRIC (BR)) WITH PRESSURE VENTILATION & HEATING, TARE 40, E.T.H. 3 PLUS 600 AMP WIRING, B5 BOGIES.

SLEEPING SECOND-MK 1.

CLASS ---

SLS

AS 201

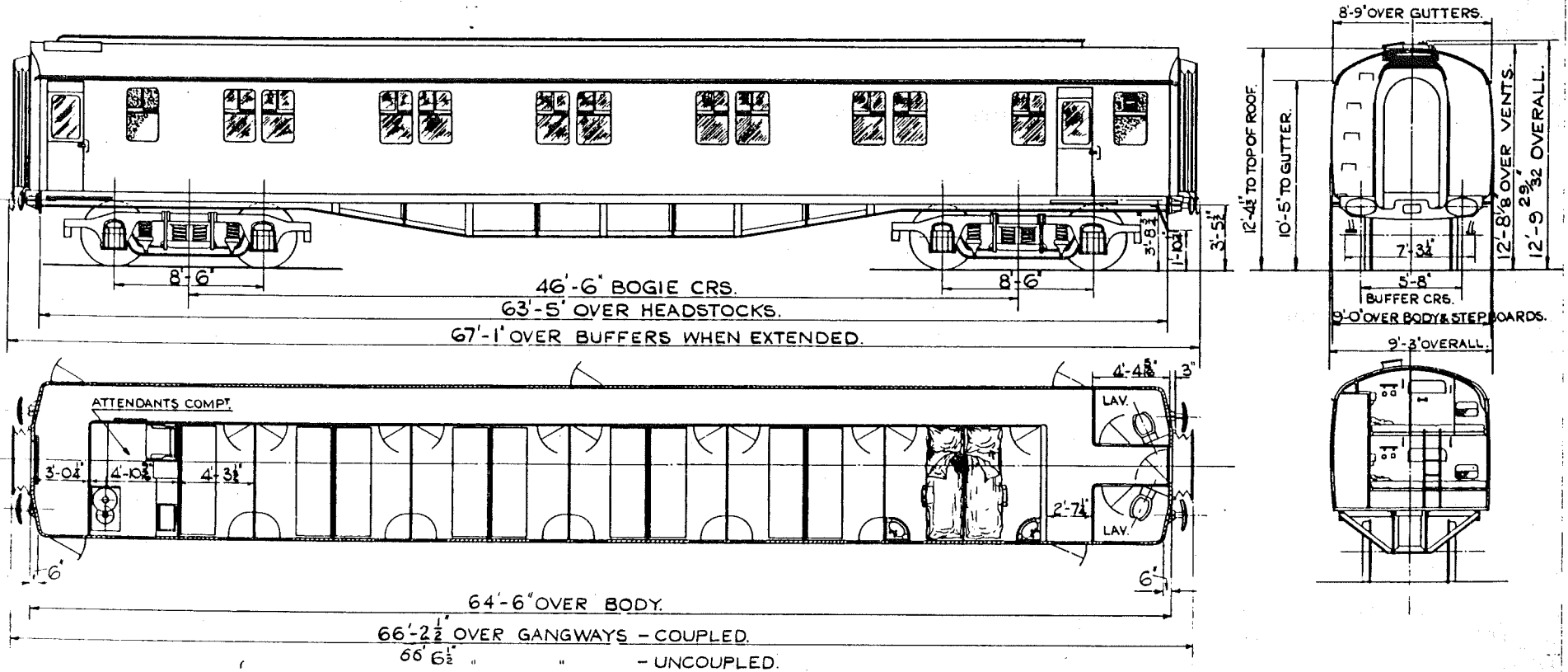

- | | |
|---------------------|------------|
| SEATS | 22 BERTHS |
| TOILETS | 2 |
| COMPARTMENTS | 11 |
| GUARDS COMPARTMENTS | - |
| VENTILATION | PRESSURE |
| CATERING EQUIPMENT | LIQUID GAS |

ORIGINAL DIAGRAMS FOR REFERENCE:-
BR 10

ISSUE 3 DATE AUG '82

AS 201

BRAKES
BOGIE/SUSPENSION
BODY CONSTRUCTION
COUPLINGS
TRAIN HEATING

E.T.H. INDEX
MAX. SPEED M.P.H.
MIN. RAD. CURVE, CHAINS
LIGHTING
TARE WEIGHT, TONNES
GANGWAYS
TRAIN COMMUNICATION
BUFFERS
BRAKE BLOCKS

BASIC TYPE

VACUUM
COMMONWEALTH
STEEL
AUTOMATIC DROPHEAD (BUCKEYE)
STEAM WITH PRESSURE VENTILATION AND HEATING

-
100
3.5
TUNGSTEN
41
PULLMAN
NOT FITTED
RETRACTABLE SPINDLE (559X356 OVAL)
CAST IRON

ALTERNATIVES

VACUUM & AIR
B5

DUAL (STEAM/ELECTRIC (BR)) WITH PRESSURE VENTILATION
& HEATING
3,3 PLUS 600 AMP WIRING

COMPOSITIONTRACTION DATA FOR MULTIPLE UNITSBASIC TYPE

AS 201 OA

VARIANTS

OC B5 BOGIES, COMPOSITION BRAKE BLOCKS.
1A DUAL (STEAM/ELECTRIC (BR)) WITH PRESSURE VENTILATION & HEATING, E.T.H.3.
1B DUAL (STEAM/ELECTRIC (BR)) WITH PRESSURE VENTILATION & HEATING, VACUUM & AIR BRAKES, B5 BOGIES, E.T.H.3.
1C DUAL (STEAM/ELECTRIC (BR)) WITH PRESSURE VENTILATION & HEATING, B5 BOGIES, E.T.H.3.
1D DUAL (STEAM/ELECTRIC (BR)) WITH PRESSURE VENTILATION & HEATING, E.T.H.3, COMPOSITION BRAKE BLOCKS.
1E DUAL (STEAM/ELECTRIC (BR)) WITH PRESSURE VENTILATION & HEATING, B5 BOGIES, E.T.H.3, COMPOSITION BRAKE BLOCKS.
2A DUAL (STEAM/ELECTRIC (BR)) WITH PRESSURE VENTILATION & HEATING, E.T.H.3 PLUS 600 AMP WIRING.
2C DUAL (STEAM/ELECTRIC (BR)) WITH PRESSURE VENTILATION & HEATING, B5 BOGIES, E.T.H.3 PLUS 600 AMP WIRING.

SLEEPING COMPOSITE-MK 1.

CLASS ---

SLC

AS 301

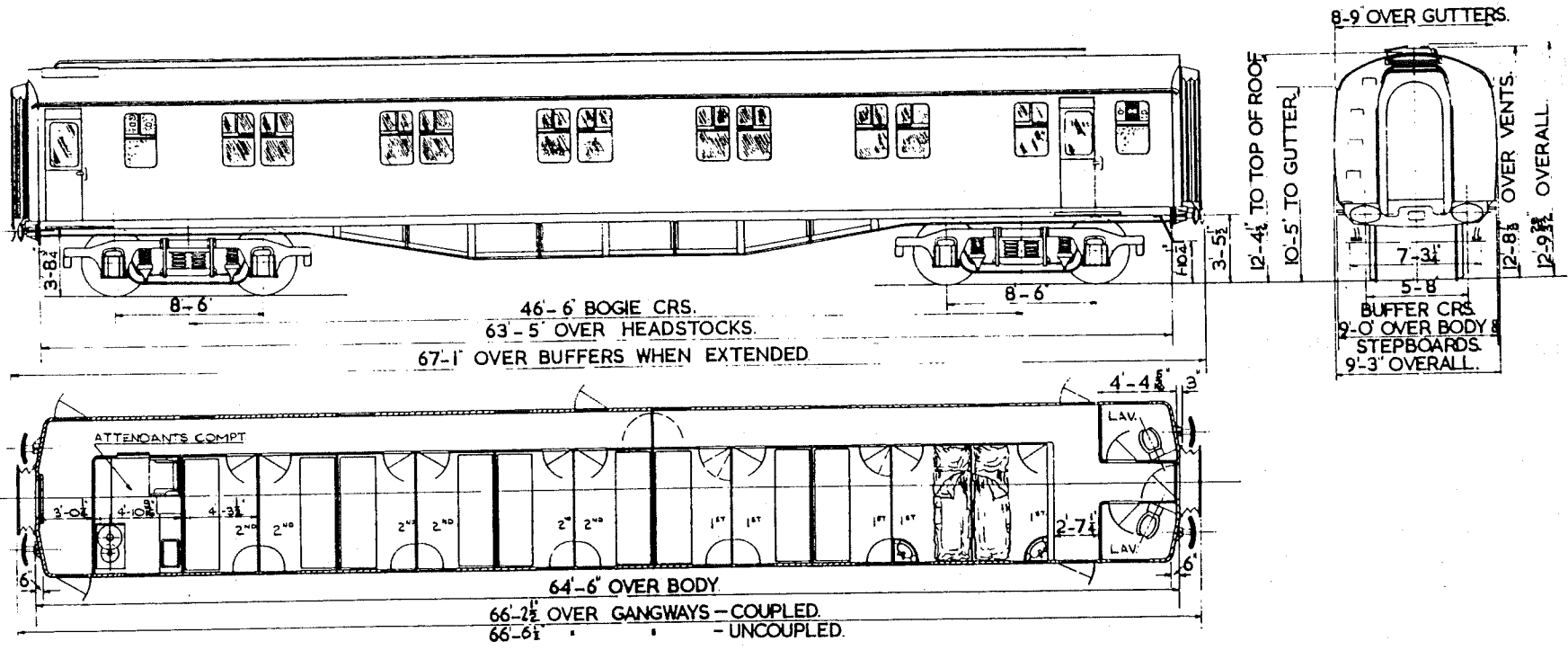

- | | |
|---------------------|---------------------------------------|
| SEATS | 5 FIRST CLASS, 12 SECOND CLASS BERTHS |
| TOILETS | 2 |
| COMPARTMENTS | 5 FIRST CLASS, 6 SECOND CLASS |
| GUARDS COMPARTMENTS | - |
| VENTILATION | PRESSURE |
| CATERING EQUIPMENT | LIQUID GAS |

ORIGINAL DIAGRAMS FOR REFERENCE:-
BR 5

ISSUE 4 DATE DEC 85

AS 301

BRAKES
BOGIE/SUSPENSION
BODY CONSTRUCTION
COUPLINGS
TRAIN HEATING

E.T.H. INDEX
MAX.SPEED M.P.H.
MIN.RAD.CURVE, CHAINS
LIGHTING
TARE WEIGHT, TONNES
GANGWAYS
TRAIN COMMUNICATION
BUFFERS

BASIC TYPE

VACUUM
COMMONWEALTH
STEEL
AUTOMATIC DROPHEAD(BUCKEYE)
STEAM WITH PRESSURE VENTILATION & HEATING

-
100
3.5
TUNGSTEN
42
PULLMAN
NOT FITTED
RETRACTABLE SPINDLE(559X356 OVAL)

ALTERNATIVES

VACUUM & AIR
B5

DUAL(STEAM/ELECTRIC(BR))WITH PRESSURE VENTILATION
& HEATING
3,3 PLUS 600 AMP WIRING
90

TRACTION DATA FOR MULTIPLE UNITSBASIC TYPE

AS 301 0A

VARIANTS

- 1A DUAL HEATING(STEAM/ELECTRIC(BR)), E.T.H.3.
- 1B B5 BOGIES, DUAL HEATING(STEAM/ELECTRIC(BR)), E.T.H.3.
- 1C VACUUM & AIR BRAKES, DUAL HEATING(STEAM/ELECTRIC(BR)), E.T.H.3.
- 2A DUAL HEATING(STEAM/ELECTRIC(BR)), E.T.H.3 PLUS 600 AMP WIRING.
- 2B B5 BOGIES, DUAL HEATING(STEAM/ELECTRIC(BR)), E.T.H.3 PLUS 600 AMP WIRING, MAX.SPEED 90.

SLEEPING EITHER CLASS-MK I

CLASS ----

SLE

AS 401

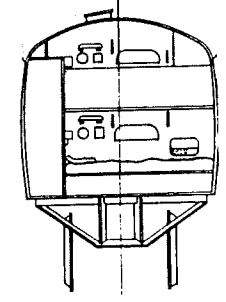
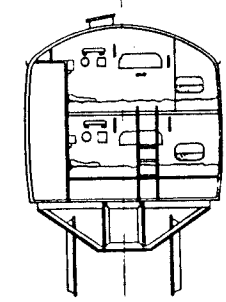
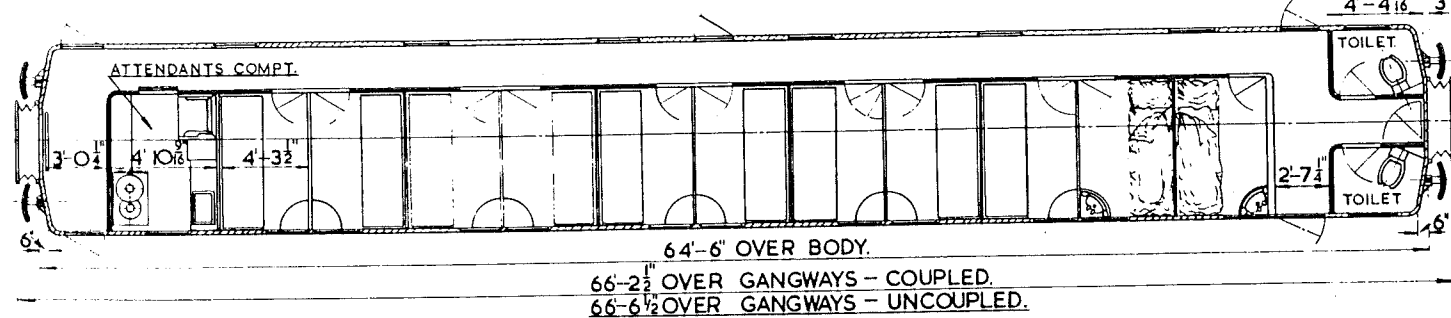
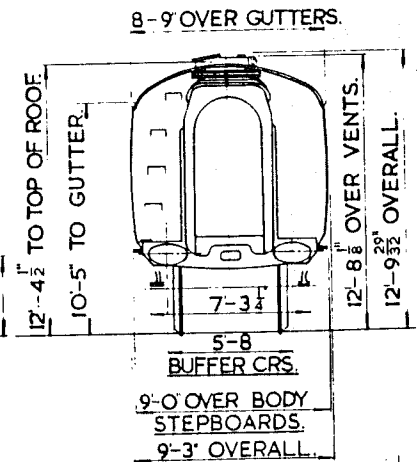
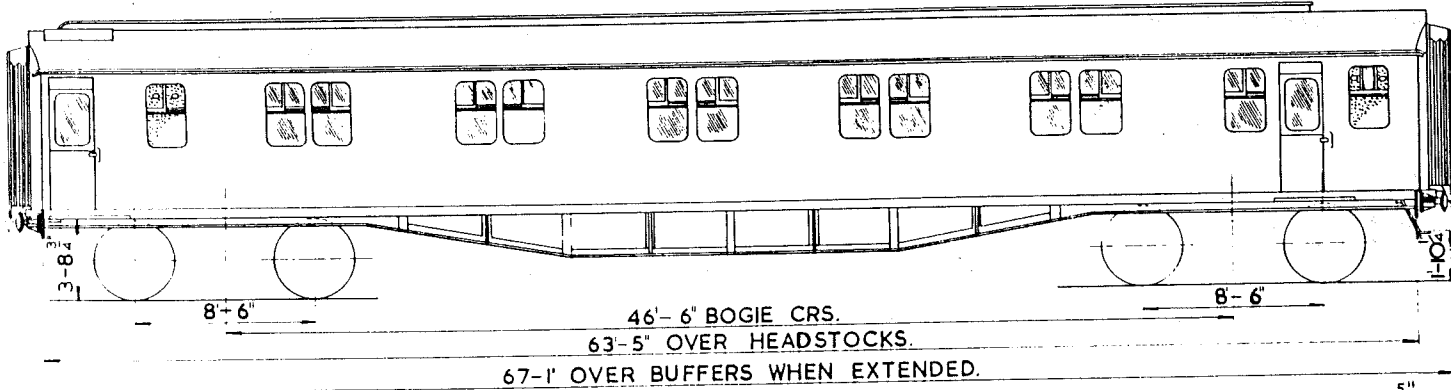

2ND ARRGT.
22 BERTHS.

1ST ARRGT.
11 BERTHS.

SEATS
TOILETS
COMPARTMENTS
GUARDS COMPARTMENTS
VENTILATION
CATERING EQUIPMENT

11 FIRST CLASS OR 22 SECOND CLASS BERTHS
2
11
-
PRESSURE
LIQUID GAS

ORIGINAL DIAGRAMS FOR REFERENCE.-
BR 14

ISSUE 2
DATE DEC '81

AS 401

BASIC TYPE

VACUUM
B5
STEEL
AUTOMATIC DROPHEAD (BUCKEYE)
STEAM WITH PRESSURE VENTILATION & HEATING
-
100
3.5
TUNGSTEN
42
PULLMAN
NOT FITTED
RETRACTABLE SPINDLE (559X356 OVAL)
CAST IRON

ALTERNATIVES

DUAL (STEAM/ELECTRIC (BR)) WITH PRESSURE VENTILATION
& HEATING
3,3 PLUS 600 AMP WIRING

BRAKES
BOGIE/SUSPENSION
BODY CONSTRUCTION
COUPLINGS
TRAIN HEATING

E.T.H. INDEX
MAX. SPEED M.P.H.
MIN. RAD. CURVE CHAINS
LIGHTING
TARE WEIGHT TONNES
GANGWAYS
TRAIN COMMUNICATION
BUFFERS
BRAKE BLOCKS

COMPOSITION

TRACTION DATA FOR MULTIPLE UNITS

BASIC TYPE

AS 401 OA

VARIANTS

- OB COMPOSITION BRAKE BLOCKS.
- 1A DUAL (STEAM/ELECTRIC (BR)) WITH PRESSURE VENTILATION & HEATING, E.T.H. 3.
- 2A DUAL (STEAM/ELECTRIC (BR)) WITH PRESSURE VENTILATION & HEATING, E.T.H. 3 PLUS 600 AMP WIRING.

SLEEPING CAR EITHER CLASS-MK I.

CLASS ----

SLE

AS 402

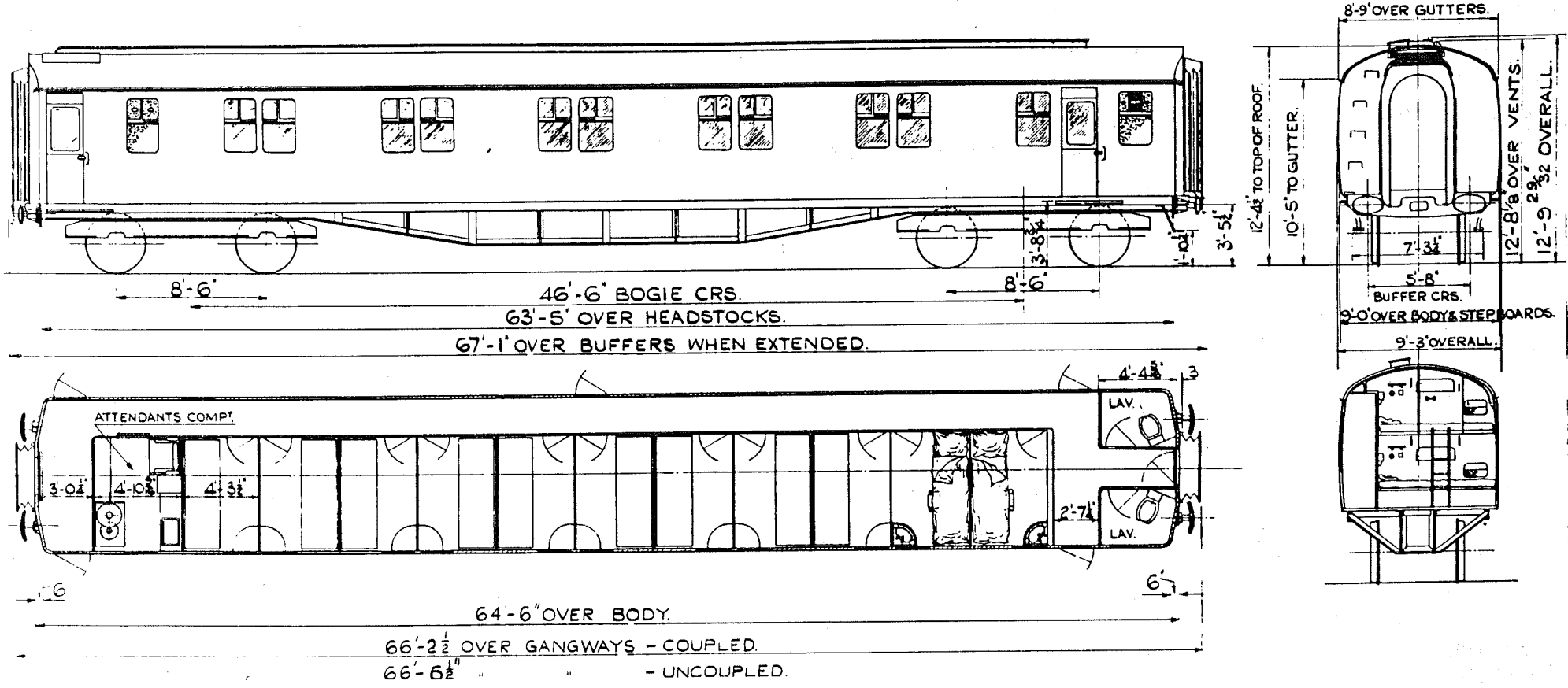

- SEATS
- TOILETS
- COMPARTMENTS
- GUARDS COMPARTMENTS
- VENTILATION
- CATERING EQUIPMENT

- 11 FIRST CLASS OR 22 SECOND CLASS BERTHS
- 2
- 11
-
- PRESSURE
- LQUID GAS

ORIGINAL DIAGRAMS FOR REFERENCE.- BR10

ISSUE 2 DATE MAY 81

AS 402

BRAKES
BOGIE/SUSPENSION
BODY CONSTRUCTION
COUPLINGS
TRAIN HEATING

E.T.H. INDEX
MAX. SPEED M.P.H.
MIN. RAD. CURVE, CHAINS
LIGHTING
TARE WEIGHT, TONNES
GANGWAYS
TRAIN COMMUNICATION
BUFFERS

BASIC TYPE

VACUUM
COMMONWEALTH
STEEL
AUTOMATIC DROPHEAD (BUCKEYE)
STEAM WITH PRESSURE VENTILATION & HEATING

-
100
3.5
TUNGSTEN
41
PULLMAN
NOT FITTED
RETRACTABLE SPINDLE (559X356 OVAL)

ALTERNATIVES

B5

DUAL (STEAM/ELECTRIC (BR)) WITH PRESSURE VENTILATION
& HEATING
3,3 PLUS 600 AMP WIRING

40.5

TRACTION DATA FOR MULTIPLE UNITSBASIC TYPE

AS 402 0A

VARIANTS

- 1A DUAL (STEAM/ELECTRIC (BR)) WITH PRESSURE VENTILATION & HEATING, E.T.H. 3.
1B DUAL (STEAM/ELECTRIC (BR)) WITH PRESSURE VENTILATION & HEATING, B5 BOGIES, E.T.H. 3.
2A DUAL (STEAM/ELECTRIC (BR)) WITH PRESSURE VENTILATION & HEATING, E.T.H. 3 PLUS 600 AMP WIRING, TARE 40.5.

SLEEPING EITHER CLASS-MK 111A

CLASS ---

SLE

AS 404

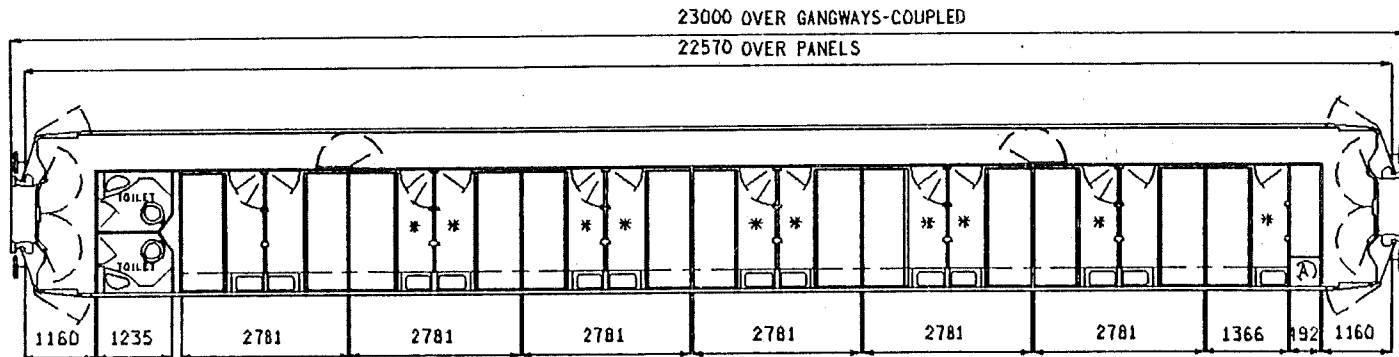
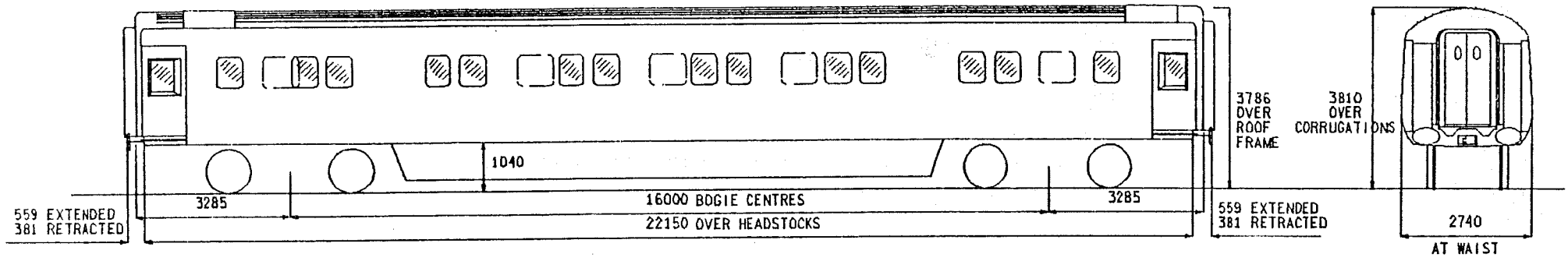

A-CIRCULATING BOILER

* THESE BERTHS NON SMOKING ON INTER-CITY VEHICLES

SEATS
TOILETS
COMPARTMENTS
GUARDS COMPARTMENTS
VENTILATION
CATERING EQUIPMENT

13 FIRST CLASS OR 26 SECOND CLASS BERTHS
2
13
-
FULL AIR CONDITIONING
-

ORIGINAL DIAGRAMS FOR REFERENCE:-
BR 6

ISSUE 3
DATE APR 87

AS 404

BASIC TYPE

ALTERNATIVES

BRAKES
BOGIE/SUSPENSION
BODY CONSTRUCTION
COUPLINGS
TRAIN HEATING
E.T.H. INDEX
MAX. SPEED M.P.H.
MIN. RAD. CURVE CHAINS
LIGHTING
TARE WEIGHT TONNES
GANGWAYS
TRAIN COMMUNICATION
BUFFERS

AIR
BT10c
STEEL
AUTOMATIC DROPHEAD (BUCKEYE)
ELECTRIC (BR) FULL AIR CONDITIONING
6 PLUS 600 AMP WIRING
125
4.5
FLUORESCENT & TUNGSTEN
43
CENTRALLY SUPPORTED-SWIVELLING-FLEXIBLE DIAPHRAGM-STEEL FACE PLATE
NOT FITTED
RETRACTABLE SPINDLE (559 X 356 OVAL)

TRACTION DATA FOR MULTIPLE UNITS

BASIC TYPE

AS 404 OA

VARIANTS

NONE

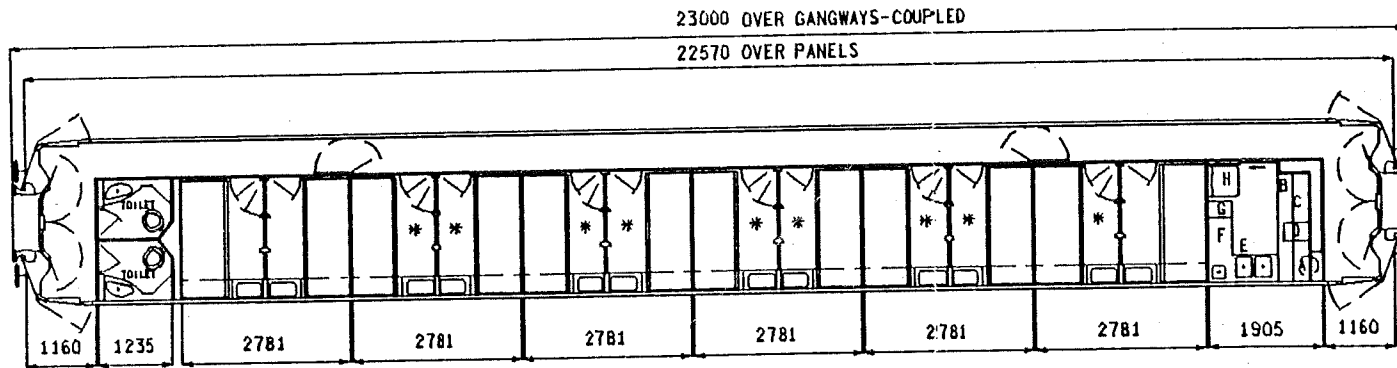
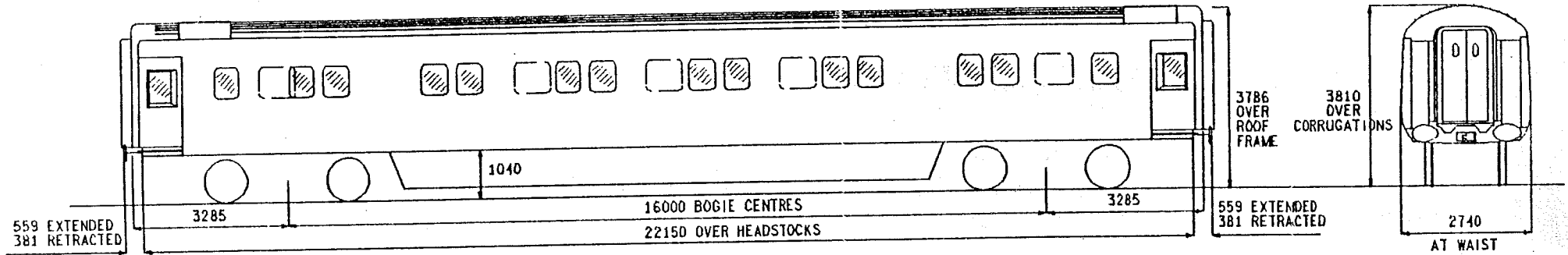

ATTENDANTS COMPARTMENT:-
 A-CIRCULATING BOILER
 B-WORK SURFACE WITH STORAGE BELOW
 C-SHELVES
 D-'STILLS' BOILER WITH FONT ABOVE
 E-SINK UNIT WITH WASTE STORAGE BELOW
 F-WORK SURFACE WITH SHELVES ABOVE & STORAGE BELOW (INCLUDING LOCKABLE DRAWER)
 G-CLOTHES LOCKER
 H-SEAT

* THESE BERTHS NON SMOKING
ON INTER-CITY VEHICLES

SEATS
TOILETS
COMPARTMENTS
GUARDS COMPARTMENTS
VENTILATION
CATERING EQUIPMENT

12 FIRST CLASS OR 24 SECOND CLASS BERTHS
2
12
-
FULL AIR CONDITIONING
ELECTRIC

ORIGINAL DIAGRAMS FOR REFERENCE:-
BR 7

ISSUE DATE
2 APR 87

AU 401

BRAKES
BOGIE/SUSPENSION
BODY CONSTRUCTION
COUPLINGS
TRAIN HEATING
E.T.H. INDEX
MAX. SPEED M.P.H.
MIN. RAD. CURVE CHAINS
LIGHTING
TARE WEIGHT TONNES
GANGWAYS
TRAIN COMMUNICATION
BUFFERS

BASIC TYPE

AIR
BT10c
STEEL
AUTOMATIC DROPHEAD (BUCKEYE)
ELECTRIC (BR) FULL AIR CONDITIONING
7 PLUS 600 AMP WIRING
125
4.5
FLUORESCENT & TUNGSTEN
43.5
CENTRALLY SUPPORTED-SWIVELLING-FLEXBLE DIAPHRAGM-STEEL FACE PLATE
NOT FITTED
RETRACTABLE SPINDLE (559 X 356 OVAL)

ALTERNATIVES

TRACTION DATA FOR MULTIPLE UNITS

BASIC TYPE

AU 401 OA

VARIANTS

NONE

BRAKE STAFF SLEEPING CAR

CLASS ---

SLSC

AU 501

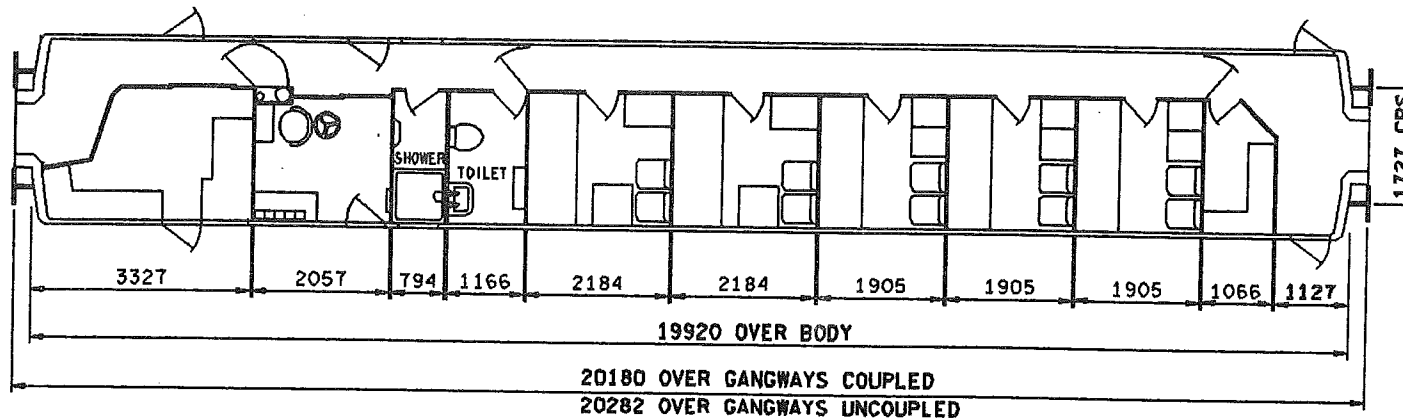
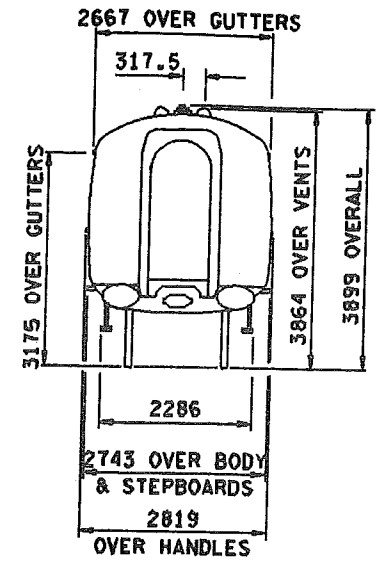
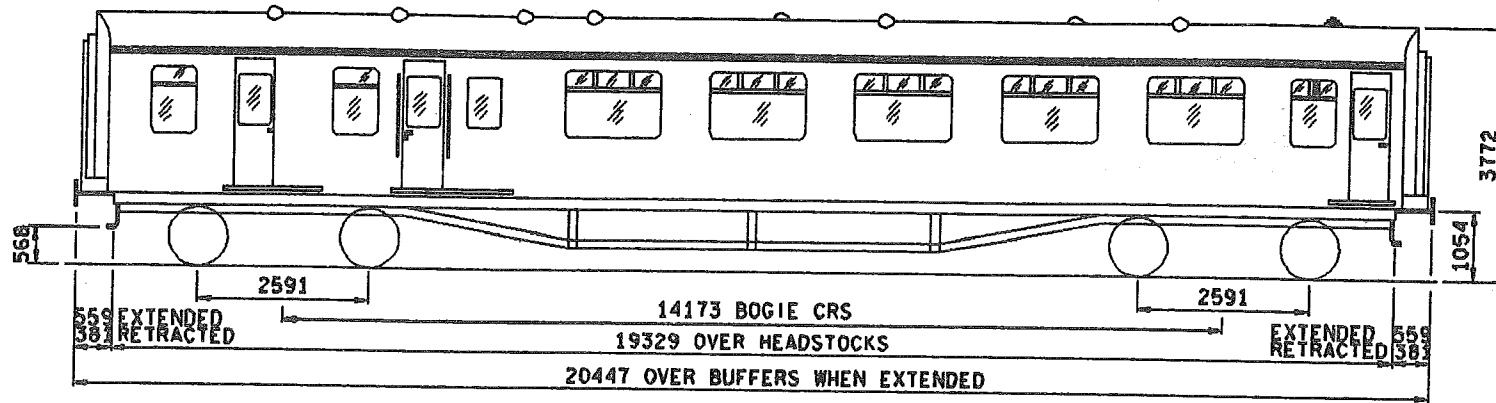

- SEATS -
- TOILETS 1
- COMPARTMENTS 5
- GUARDS COMPARTMENTS 1
- VENTILATION -
- CATERING EQUIPMENT -

ISSUE 1 DATE OCT 88

AU 501

BRAKES
BOGIE/SUSPENSION
BODY CONSTRUCTION
COUPLINGS
TRAIN HEATING
E.T.H. INDEX
MAX. SPEED M.P.H.
MIN. RAD. CURVE CHAINS
LIGHTING
TARE WEIGHT TONNES
GANGWAYS
TRAIN COMMUNICATION
BUFFERS

BASIC TYPE

AIR
COMMONWEALTH
STEEL
AUTOMATIC DROPHEAD (BUCKEYE)
ELECTRIC (BR)
3
100
3.5
FLUORESCENT
36
PULLMAN
P.A. WITH TRANSMITTER
RETRACTABLE SPINDLE (559X356 OVAL)

ALTERNATIVES

TRACTION DATA FOR MULTIPLE UNITS

BASIC TYPE

AU 501 0A

VARIANTS

NONE

SECOND-NARROW GAUGE-OPEN

CLASS ---

S

AX 201

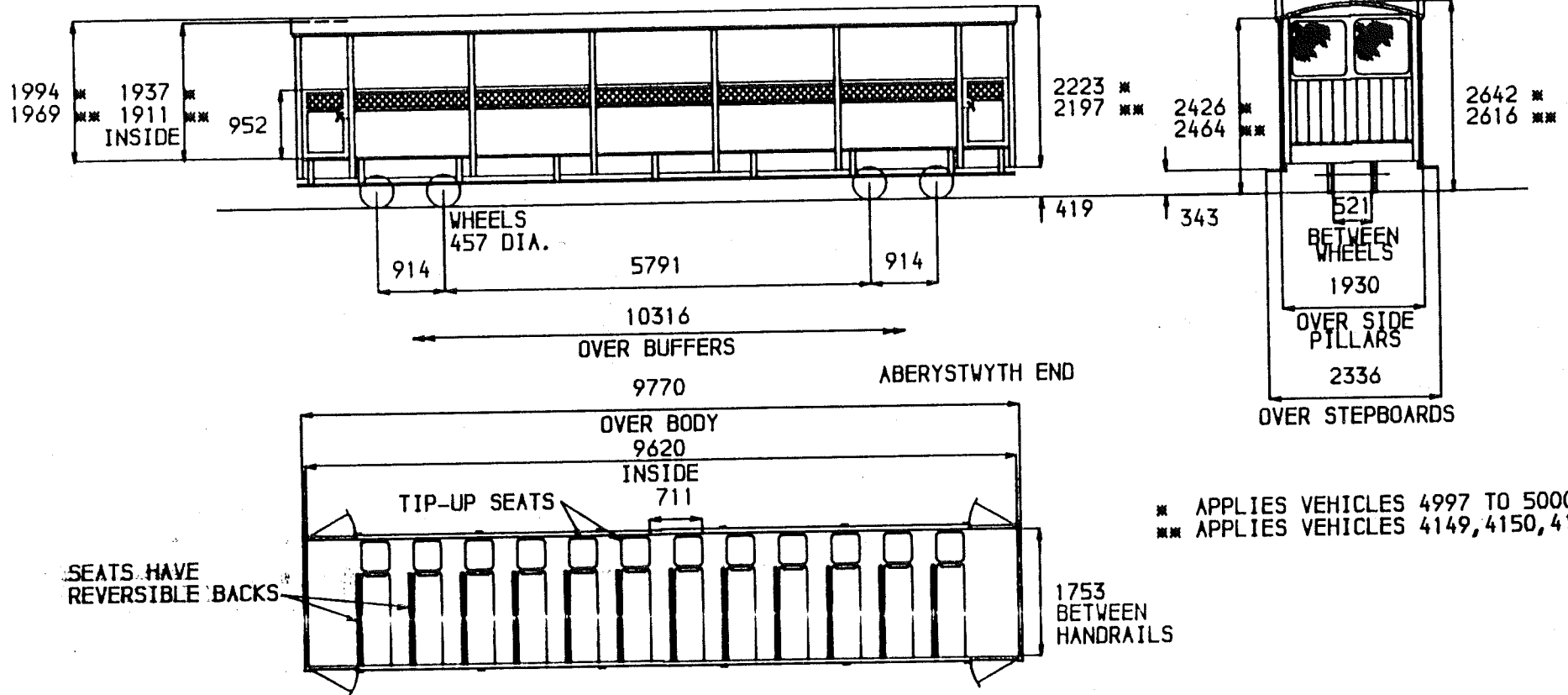

- SEATS 48
- TOILETS -
- COMPARTMENTS -
- GUARDS COMPARTMENTS -
- VENTILATION -
- CATERING EQUIPMENT -

ORIGINAL DIAGRAMS FOR REFERENCE.-
WR C48

ISSUE 1 DATE SEP' 80

AX 201

BRAKES
BOGIE/SUSPENSION
BODY CONSTRUCTION
COUPLINGS
TRAIN HEATING
E.T.H. INDEX
MAX. SPEED M.P.H.
MIN. RAD. CURVE CHAINS
LIGHTING
TARE WEIGHT TONNES
GANGWAYS
TRAIN COMMUNICATION
BUFFERS

BASIC TYPE

VACUUM
REGIONALLY UNIDENTIFIED
STEEL UNDERFRAME-STEEL/WOODEN BODY-WOODEN BODY FRAMING & ROOF
CENTRE
STEAM
-
20
NO RECORD
-
NO RECORD
NO RECORD
NOT FITTED
CENTRE

ALTERNATIVES

TRACTION DATA FOR MULTIPLE UNITS

BASIC TYPE

AX 201 0A

VARIANTS

NONE

SECOND-NARROW GAUGE-OPEN

CLASS ---

S

AX 202

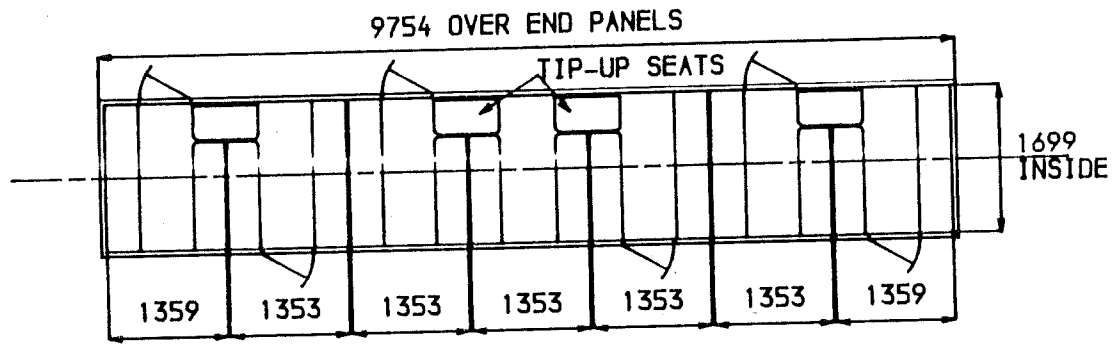
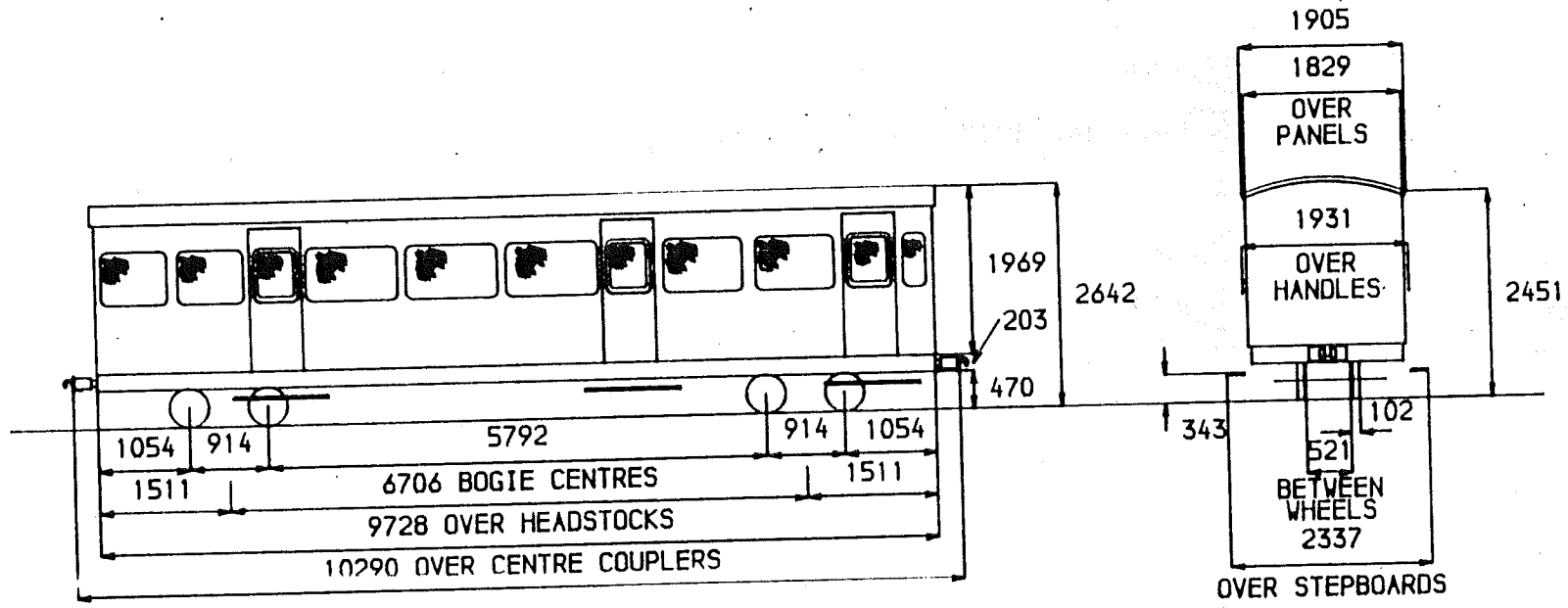

SEATS	56
TOILETS	-
COMPARTMENTS	-
GUARDS COMPARTMENTS	-
VENTILATION	-
CATERING EQUIPMENT	-

ORIGINAL DIAGRAMS FOR REFERENCE.-
WR C78

ISSUE 1 DATE SEP' 80

AX 202

BRAKES
BOGIE/SUSPENSION
BODY CONSTRUCTION
COUPLINGS
TRAIN HEATING
E.T.H. INDEX
MAX. SPEED M.P.H.
MIN. RAD. CURVE CHAINS
LIGHTING
TARE WEIGHT TONNES
GANGWAYS
TRAIN COMMUNICATION
BUFFERS

BASIC TYPE

VACUUM
REGIONALLY UNIDENTIFIED
STEEL UNDERFRAME & BODY-WOODEN BODY FRAMING & ROOF
NO RECORD
STEAM
-
20
NO RECORD
-
NO RECORD
NOT FITTED
NOT FITTED
NOT FITTED

ALTERNATIVES

TRACTION DATA FOR MULTIPLE UNITS

BASIC TYPE

AX 202 0A

VARIANTS

NONE

SECOND-NARROW GAUGE-OPEN (VISTA)

CLASS ---

S

AX 203

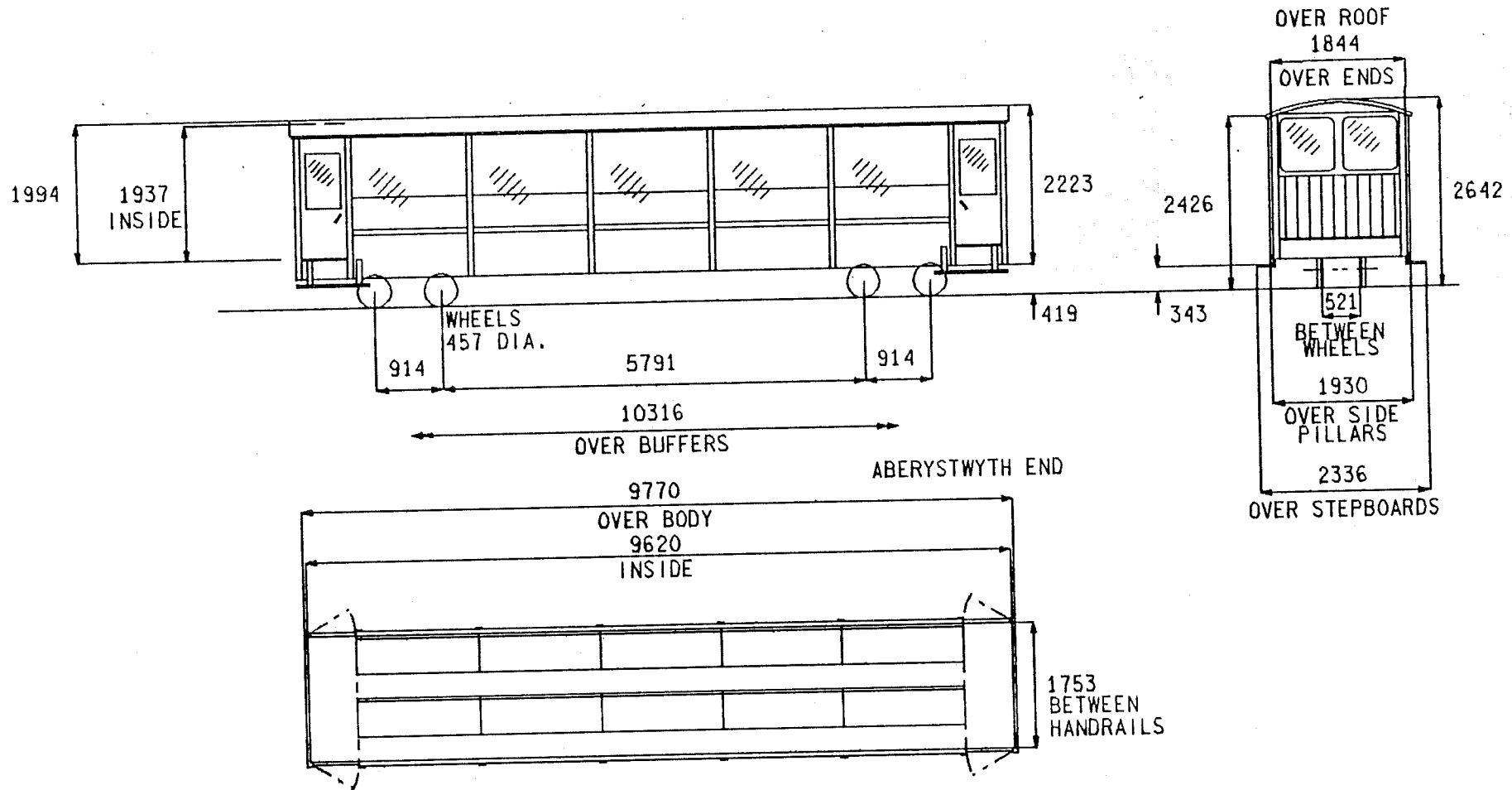

- SEATS
- TOILETS
- COMPARTMENTS
- GUARDS COMPARTMENTS
- VENTILATION
- CATERING EQUIPMENT

30
-
-
-
-
-

ISSUE 1 DATE JAN 84

AX 203

BRAKES
BOGIE/SUSPENSION
BODY CONSTRUCTION
COUPLINGS
TRAIN HEATING
E.T.H. INDEX
MAX. SPEED M.P.H.
MIN. RAD. CURVE CHAINS
LIGHTING
TARE WEIGHT TONNES
GANGWAYS
TRAIN COMMUNICATION
BUFFERS

BASIC TYPE

VACUUM
REGIONALLY UNIDENTIFIED
STEEL UNDERFRAME-STEEL/WOODEN BODY-WOODEN BODY FRAMING & ROOF
CENTRE
STEAM
-
20
NO RECORD
-
NO RECORD
NO RECORD
NOT FITTED
CENTRE

ALTERNATIVES

TRACTION DATA FOR MULTIPLE UNITS

BASIC TYPE

AX 203 0A

VARIANTS

NONE

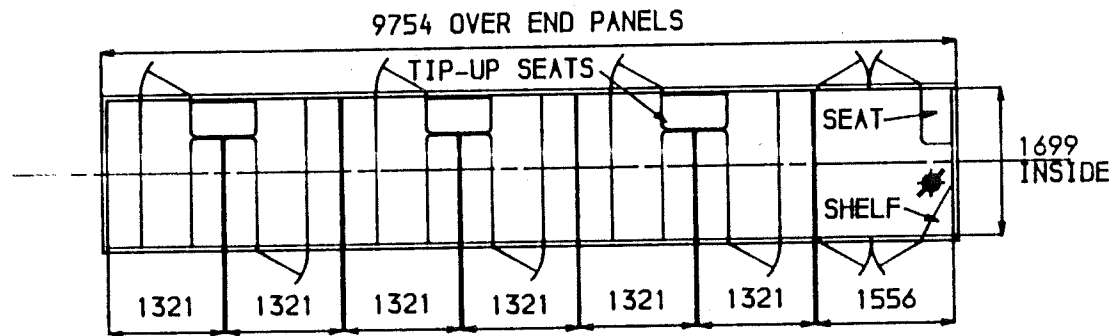
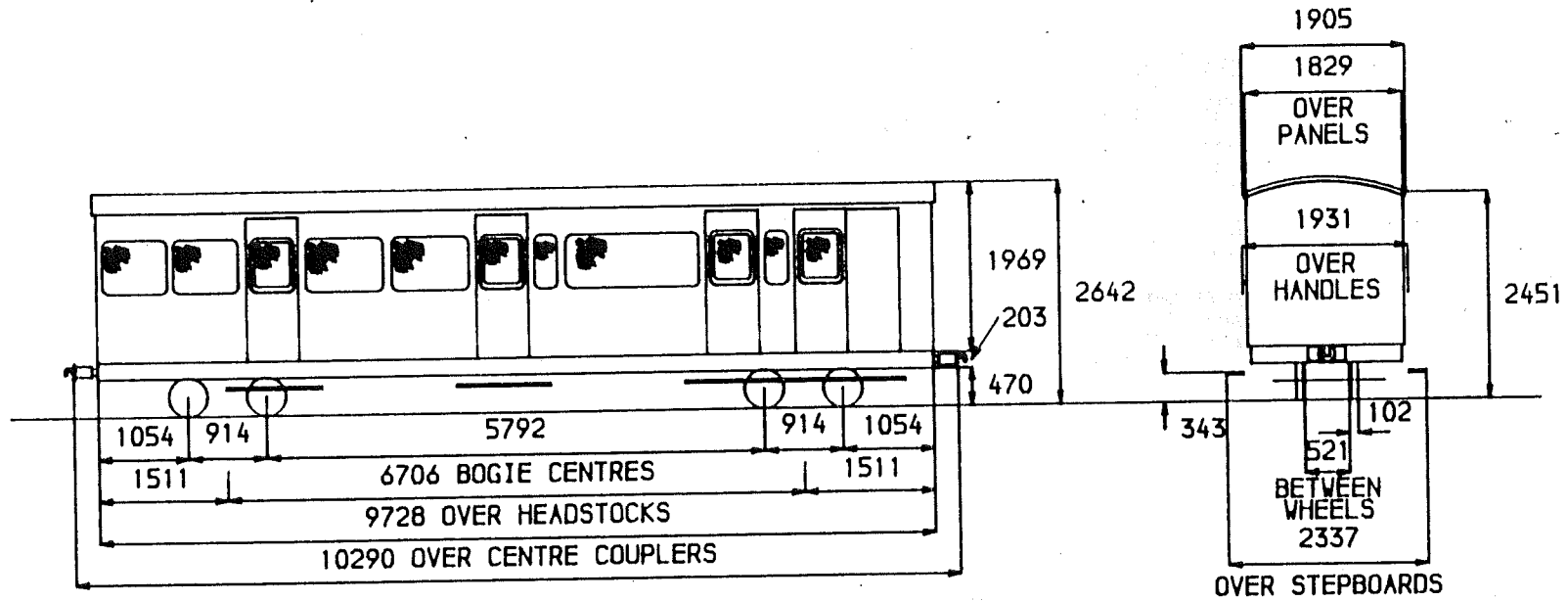

SEATS	48
TOILETS	-
COMPARTMENTS	-
GUARDS COMPARTMENTS	1
VENTILATION	-
CATERING EQUIPMENT	-

ORIGINAL DIAGRAMS FOR REFERENCE.-
WR D128

ISSUE 1 DATE SEP' 80

AY 201

BRAKES
BOGIE/SUSPENSION
BODY CONSTRUCTION
COUPLINGS
TRAIN HEATING
E.T.H. INDEX
MAX. SPEED M.P.H.
MIN. RAD. CURVE CHAINS
LIGHTING
TARE WEIGHT TONNES
GANGWAYS
TRAIN COMMUNICATION
BUFFERS

BASIC TYPE

VACUUM
REGIONAL UNIDENTIFIED
STEEL UNDERFRAME & BODY, WOODEN BODY FRAMING & ROOF
NO RECORD
STEAM
-
20
NO RECORD
-
NO RECORD
NOT FITTED
NOT FITTED
NOT FITTED

ALTERNATIVES

TRACTION DATA FOR MULTIPLE UNITS

BASIC TYPE

AY 201 0A

VARIANTS

NONE

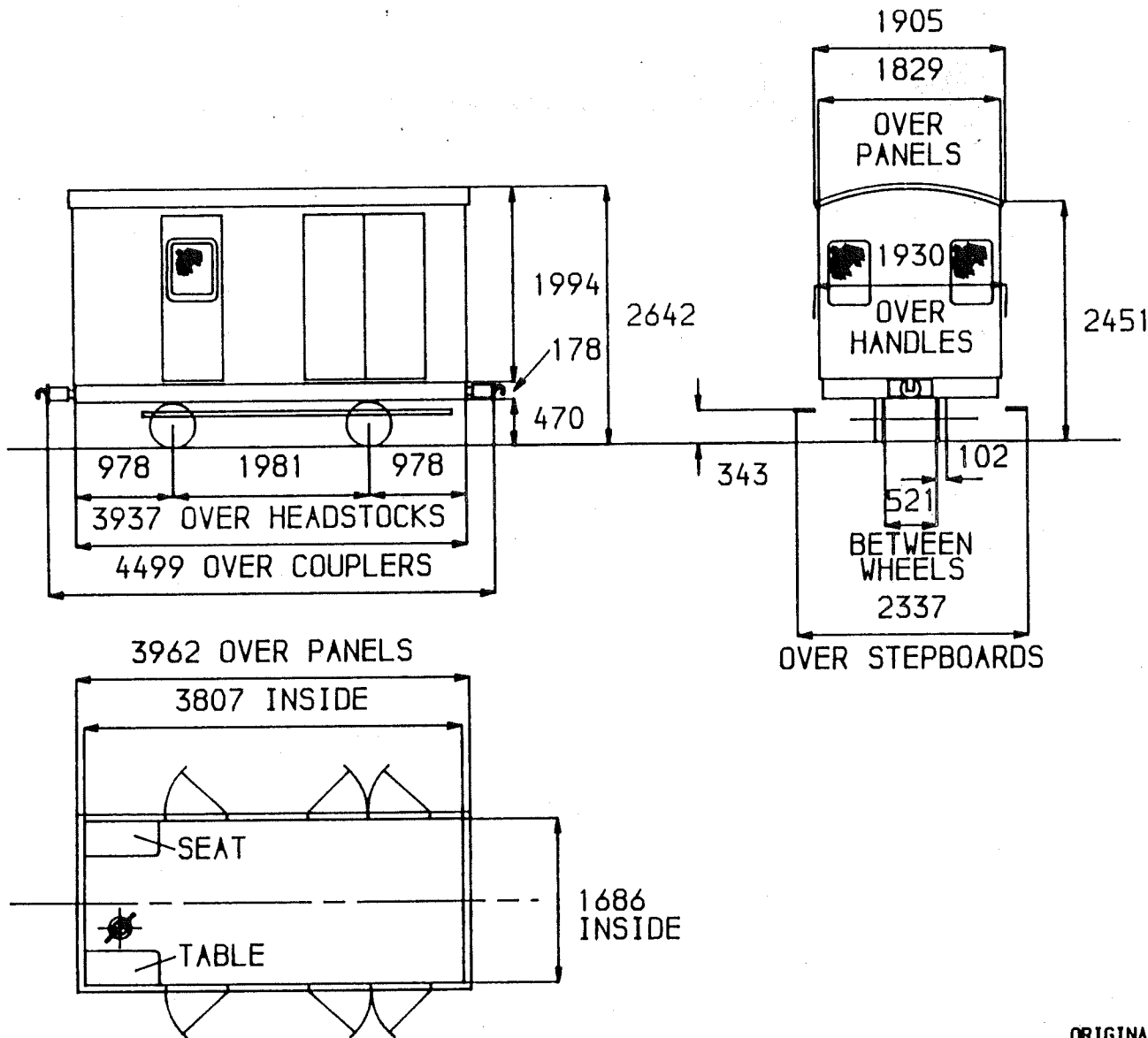

SEATS
TOILETS
COMPARTMENTS
GUARDS COMPARTMENTS
VENTILATION
CATERING EQUIPMENT

-
-
-
-
-
-

ORIGINAL DIAGRAMS FOR REFERENCE.-
VR K43

ISSUE 1 DATE SEP' 80

AY 202

BRAKES
BOGIE/SUSPENSION
BODY CONSTRUCTION
COUPLINGS
TRAIN HEATING
E.T.H. INDEX
MAX. SPEED M.P.H.
MIN. RAD. CURVE CHAINS
LIGHTING
TARE VEIGHT TONNES
GANGWAYS
TRAIN COMMUNICATION
BUFFERS

BASIC TYPE

VACUUM
REGIONAL UNIDENTIFIED
STEEL UNDERFRAME & BODY-WOODEN BODY FRAMING & ROOF
NO RECORD
STEAM
-
20
0.6
-
3.5
NOT FITTED
NOT FITTED
NOT FITTED

ALTERNATIVES

TRACTION DATA FOR MULTIPLE UNITS

BASIC TYPE
AY 202 0A

VARIANTS
NONE

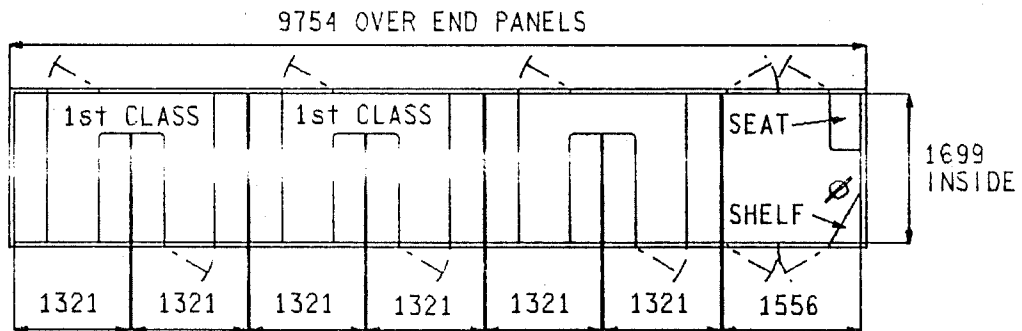
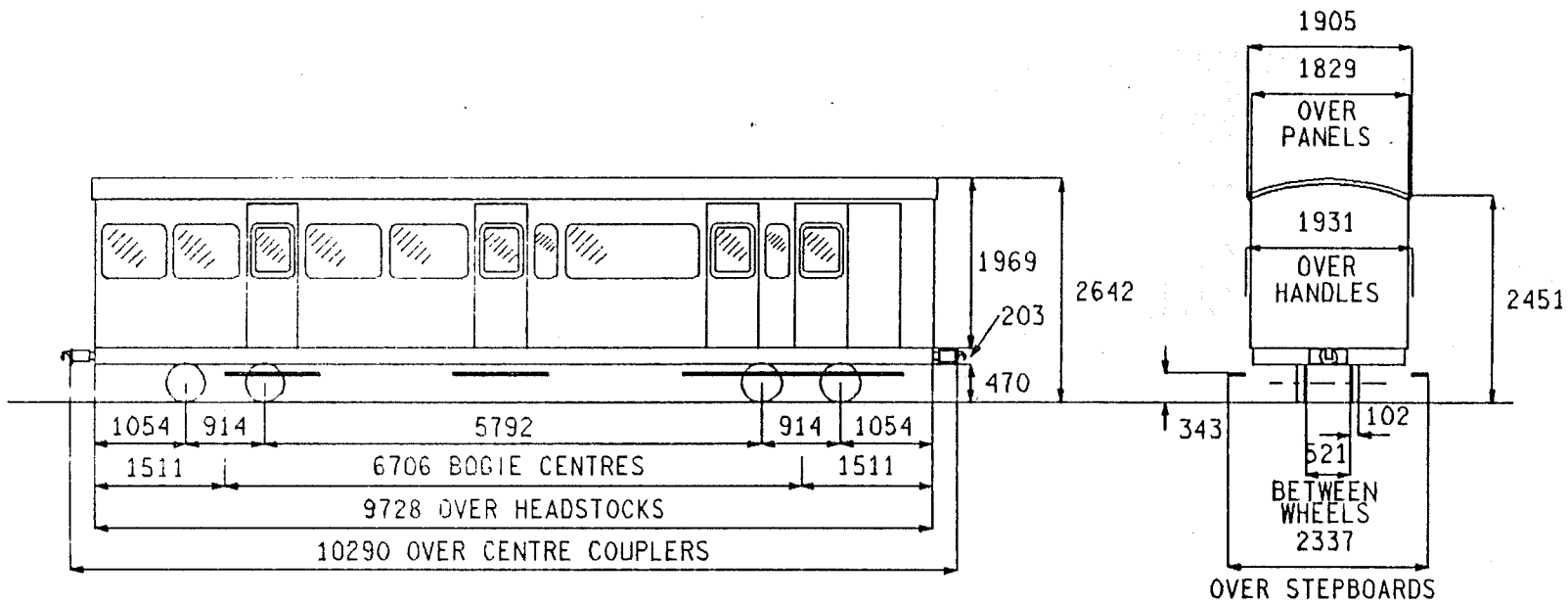

SEATS 28 FIRST CLASS,16 SECOND CLASS
 TOILETS -
 COMPARTMENTS -
 GUARDS COMPARTMENTS 1
 VENTILATION -
 CATERING EQUIPMENT -

ORIGINAL DIAGRAMS FOR REFERENCE:-
 WR D128

ISSUE 1 DATE JAN 84

AY 301

ALTERNATIVES

BASIC TYPE

BRAKES
BOGIE/SUSPENSION
BODY CONSTRUCTION
COUPLINGS
TRAIN HEATING
E.T.H. INDEX
MAX. SPEED M.P.H.
MIN. RAD. CURVE CHAINS
LIGHTING
TARE WEIGHT TONNES
GANGWAYS
TRAIN COMMUNICATION
BUFFERS

VACUUM
REGIONAL UNIDENTIFIED
STEEL UNDERFRAME & BODY, WOODEN BODY FRAMING & ROOF
NO RECORD
STEAM
-
20
NO RECORD
-
NO RECORD
NOT FITTED
NOT FITTED
NOT FITTED

TRACTION DATA FOR MULTIPLE UNITS

BASIC TYPE

AY 301 0A

VARIANTS

NONE

POST OFFICE SORTING VAN-MK I

CLASS ---

POS

NS 501

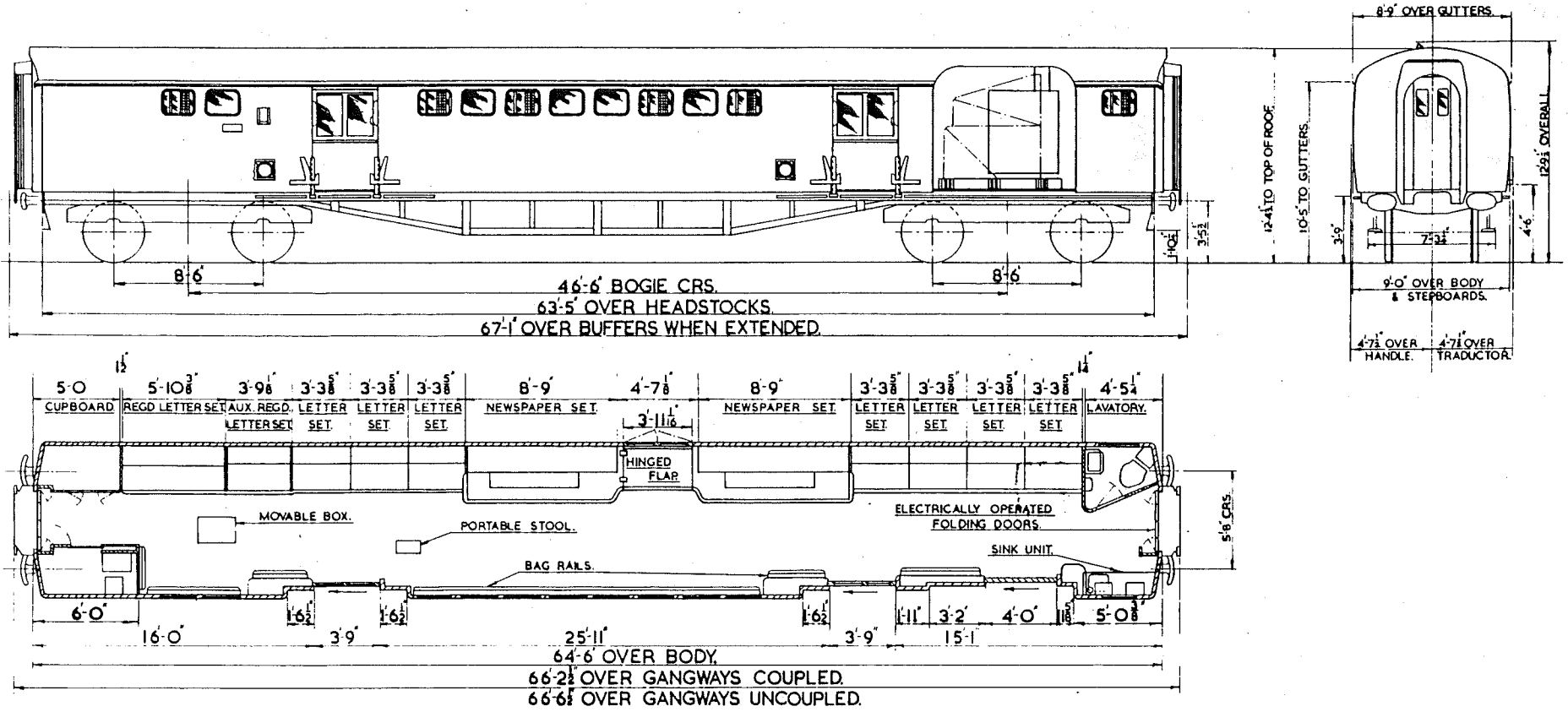

- SEATS -
- TOILETS - SEE VARIANTS
- COMPARTMENTS -
- GUARDS COMPARTMENTS -
- VENTILATION -
- CATERING EQUIPMENT -

ORIGINAL DIAGRAMS FOR REFERENCE.-
BR 720

ISSUE 1 DATE SEP' 80

NS 501

BRAKES
 BOGIE/SUSPENSION
 BODY CONSTRUCTION
 COUPLINGS
 TRAIN HEATING
 E.T.H. INDEX
 MAX. SPEED H.P.H.
 MIN. RAD. CURVE CHAINS
 LIGHTING
 TARE WEIGHT TONNES
 GANGWAYS
 TRAIN COMMUNICATION
 BUFFERS
 TOILETS

BASIC TYPE

VACUUM
 BR STANDARD MK 2
 STEEL
 AUTOMATIC DROPHEAD (BUCKEYE)
 DUAL (STEAM/ELECTRIC (BR))
 3
 90
 3.5
 ELECTRIC
 37
 PULLMAN
 NOT FITTED
 RETRACTABLE SPINDLE-559 X 356 OVAL
 1

ALTERNATIVES

3 PLUS 600 AMP WIRING

36

NOT FITTED

TRACION DATA FOR MULTIPLE UNITS

BASIC TYPE

NS 501 1A

VARIANTS

2A E.T.H. 3 PLUS 600 AMP WIRING, TARE 36, TOILET NOT FITTED.

POST OFFICE SORTING VAN-MK I

CLASS ---

POS

NS 502

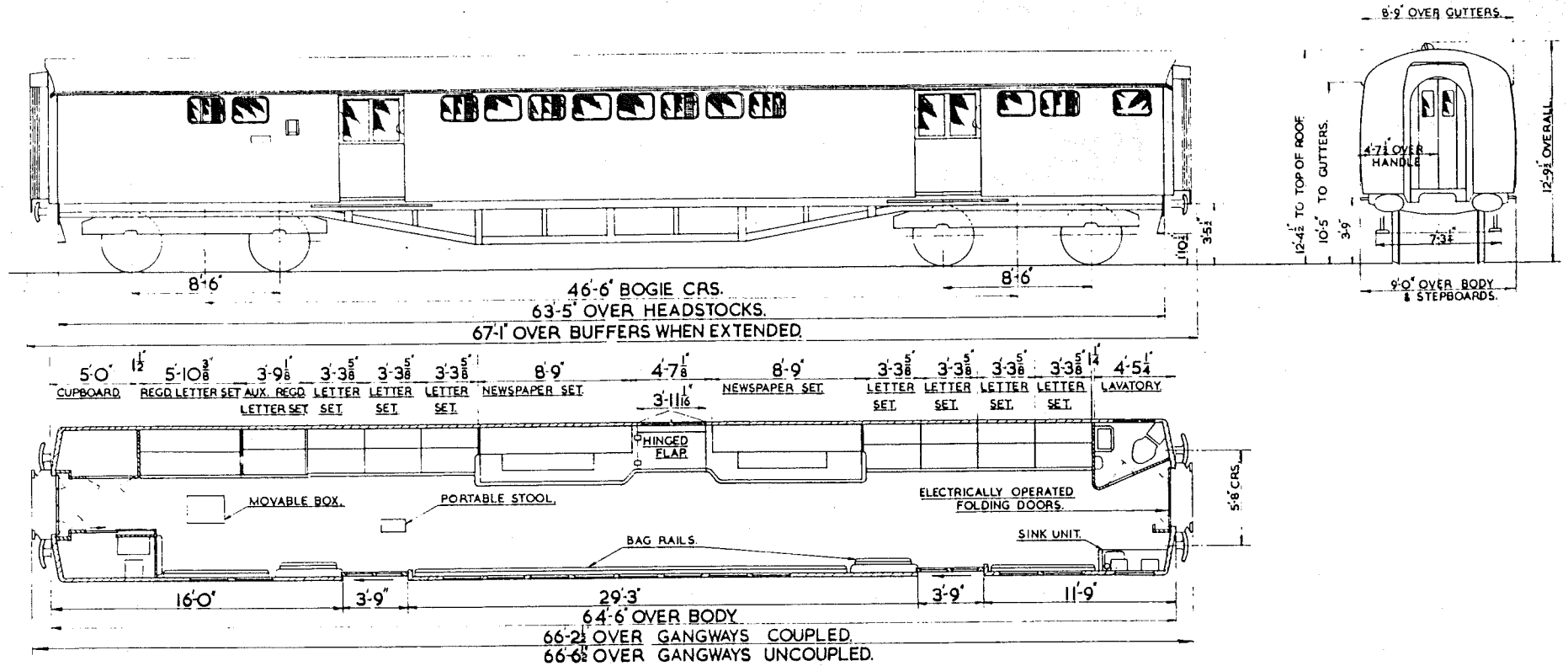

- SEATS -
- TOILETS - 1
- COMPARTMENTS -
- GUARDS COMPARTMENTS -
- VENTILATION -
- CATERING EQUIPMENT -

ORIGINAL DIAGRAMS FOR REFERENCE.--
BR 721

ISSUE 1 DATE SEP' 80

NS 502

BRAKES
BOGIE/SUSPENSION
BODY CONSTRUCTION
COUPLINGS
TRAIN HEATING
E.T.H. INDEX
MAX. SPEED M.P.H.
MIN. RAD. CURVE CHAINS
LIGHTING
TARE WEIGHT TONNES
GANGWAYS
TRAIN COMMUNICATION
BUFFERS

BASIC TYPE

VACUUM
BR STANDARD MK 2
STEEL
AUTOMATIC DROPHEAD (BUCKEYE)
DUAL (STEAM/ELECTRIC (BR))
3
90
3.5
ELECTRIC
36
PULLMAN
NOT FITTED
RETRACTABLE SPINDLE-559 X 356 OVAL

ALTERNATIVES

TRACTION DATA FOR MULTIPLE UNITS

BASIC TYPE

NS 502 1A

VARIANTS

NONE

POST OFFICE SORTING VAN-MK I

CLASS ---

POS

NS 503

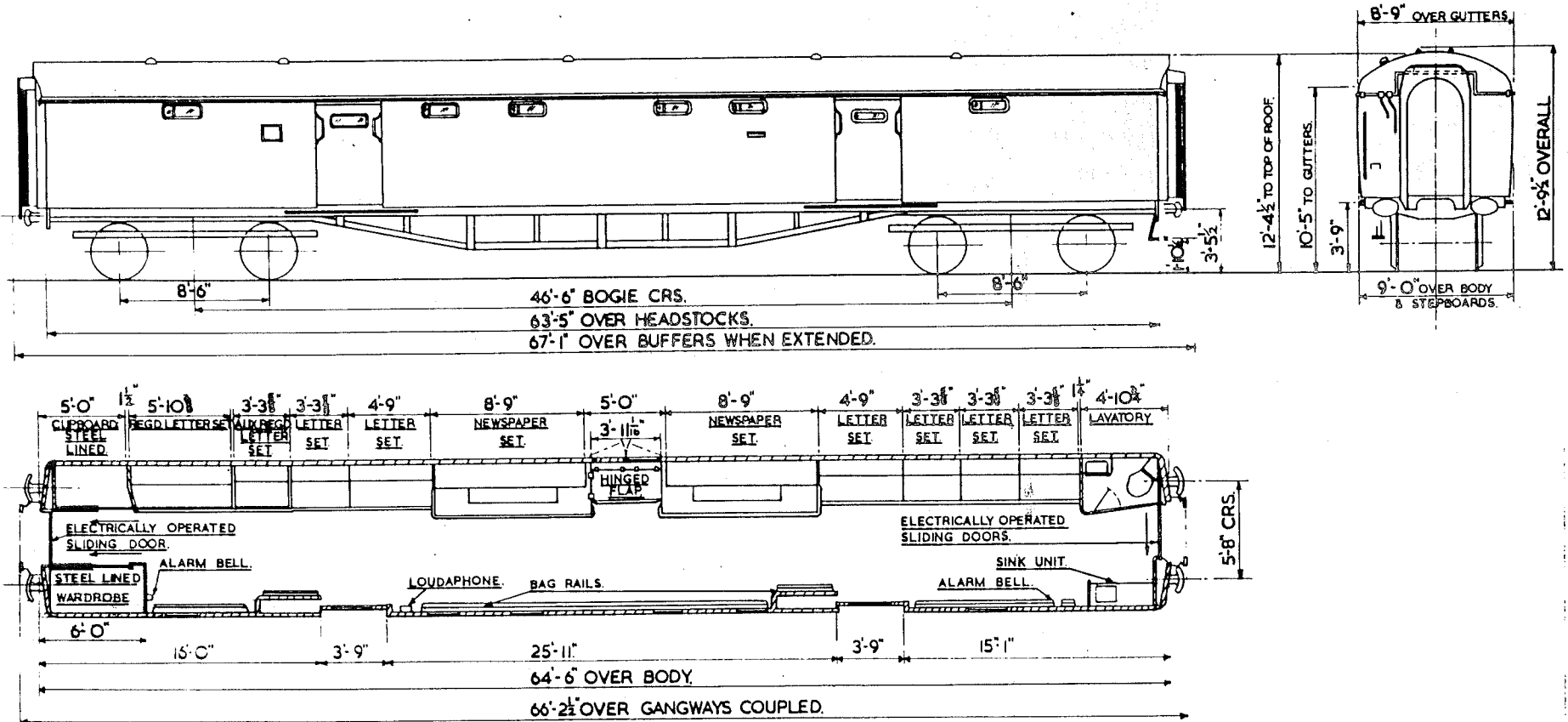

- SEATS -
- TOILETS - 1
- COMPARTMENTS -
- GUARDS COMPARTMENTS -
- VENTILATION -
- CATERING EQUIPMENT -
- PRESSURE -

ORIGINAL DIAGRAMS FOR REFERENCE.-
BR 726A

ISSUE 1 DATE SEP '60

NS 503

BRAKES
 BOGIE/SUSPENSION
 BODY CONSTRUCTION
 COUPLINGS
 TRAIN HEATING
 E.T.H. INDEX
 MAX. SPEED M.P.H.
 MIN. RAD. CURVE CHAINS
 LIGHTING
 TARE WEIGHT TONNES
 GANGWAYS
 TRAIN COMMUNICATION
 BUFFERS

BASIC TYPE

VACUUM & AIR
 BS
 STEEL
 AUTOMATIC DROPHEAD (BUCKEYE)
 DUAL (STEAM/ELECTRIC (BR)) WITH PRESSURE VENTILATION & HEATING
 4 PLUS 600 AMP WIRING
 100
 3.5
 FLUORESCENT & TUNGSTEN
 37
 PULLMAN
 COACH/COACH LOUDAPHONE
 RETRACTABLE SPINDLE-559 X 356 OVAL

ALTERNATIVES

TRACTION DATA FOR MULTIPLE UNITS

BASIC TYPE

NS 503 0A

VARIANTS

NONE

POST OFFICE SORTING VAN-MK I

CLASS ----

POS

NS 504

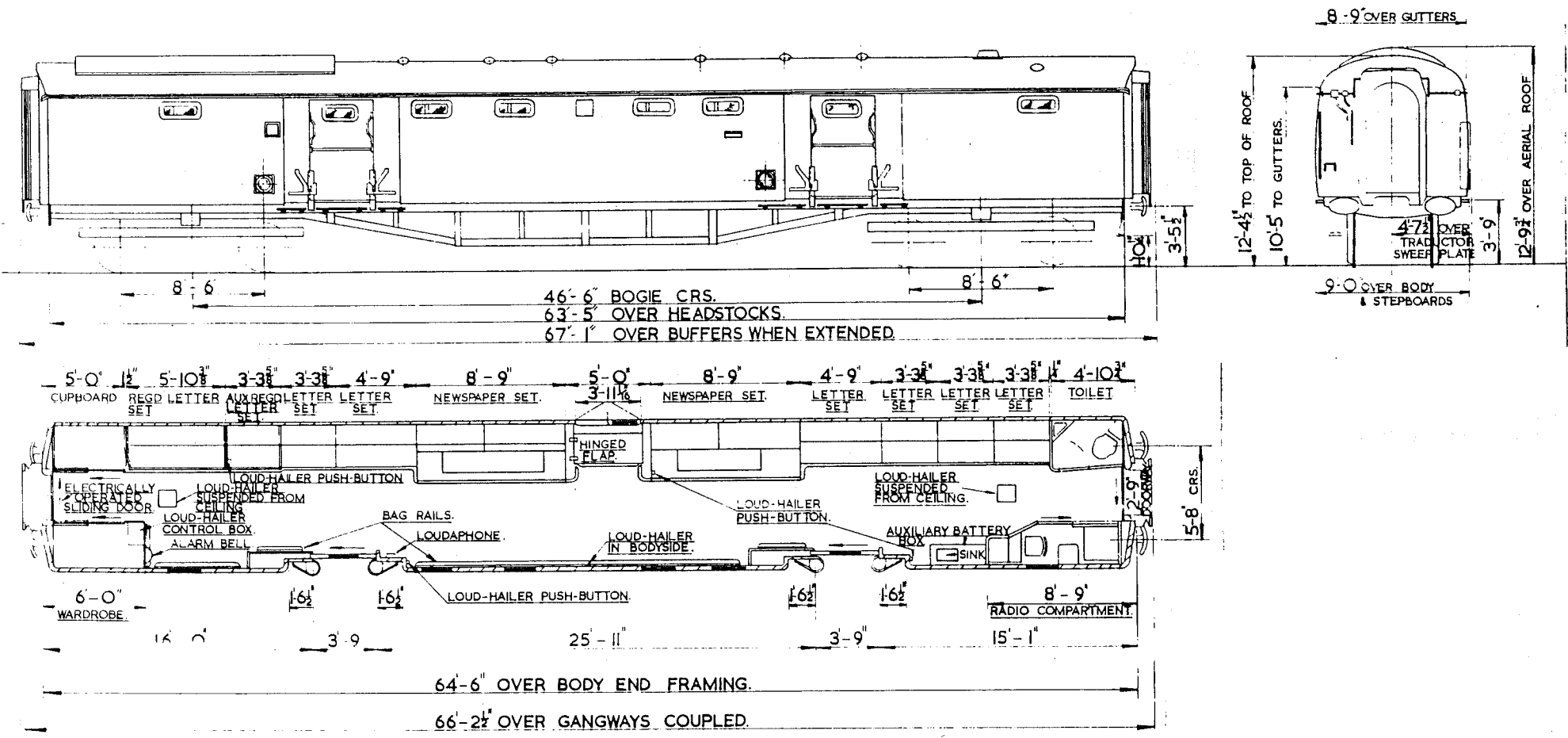

- SEATS -
- TOILETS - 1
- COMPARTMENTS -
- GUARDS COMPARTMENTS -
- VENTILATION - PRESSURE
- CATERING EQUIPMENT -

ORIGINAL DIAGRAMS FOR REFERENCE.-
BR 728

ISSUE 2 DATE MAY '81

NS 504

BRAKES
 BOGIE/SUSPENSION
 BODY CONSTRUCTION
 COUPLINGS
 TRAIN HEATING
 E.T.H. INDEX
 MAX. SPEED M.P.H.
 MIN. RAD. CURVE CHAINS
 LIGHTING
 TARE WEIGHT TONNES
 GANGWAYS
 TRAIN COMMUNICATION
 BUFFERS

BASIC TYPE

VACUUM & AIR
 B5
 STEEL
 AUTOMATIC DROPHEAD (BUCKEYE)
 DUAL (STEAM/ELECTRIC (BR)) WITH PRESSURE VENTILATION & HEATING
 4
 100
 4.5
 TUNGSTEN
 39
 PULLMAN
 RADIO-COACH/COACH LOUDPHONE-LOUD HAILER
 RETRACTABLE SPINDLE-559 X 356 OVAL

ALTERNATIVES

TRACTION DATA FOR MULTIPLE UNITS

BASIC TYPE

NS 504 0B

VARIANTS

NONE

POST OFFICE SORTING VAN-MK I

CLASS ---

POS

NS 505

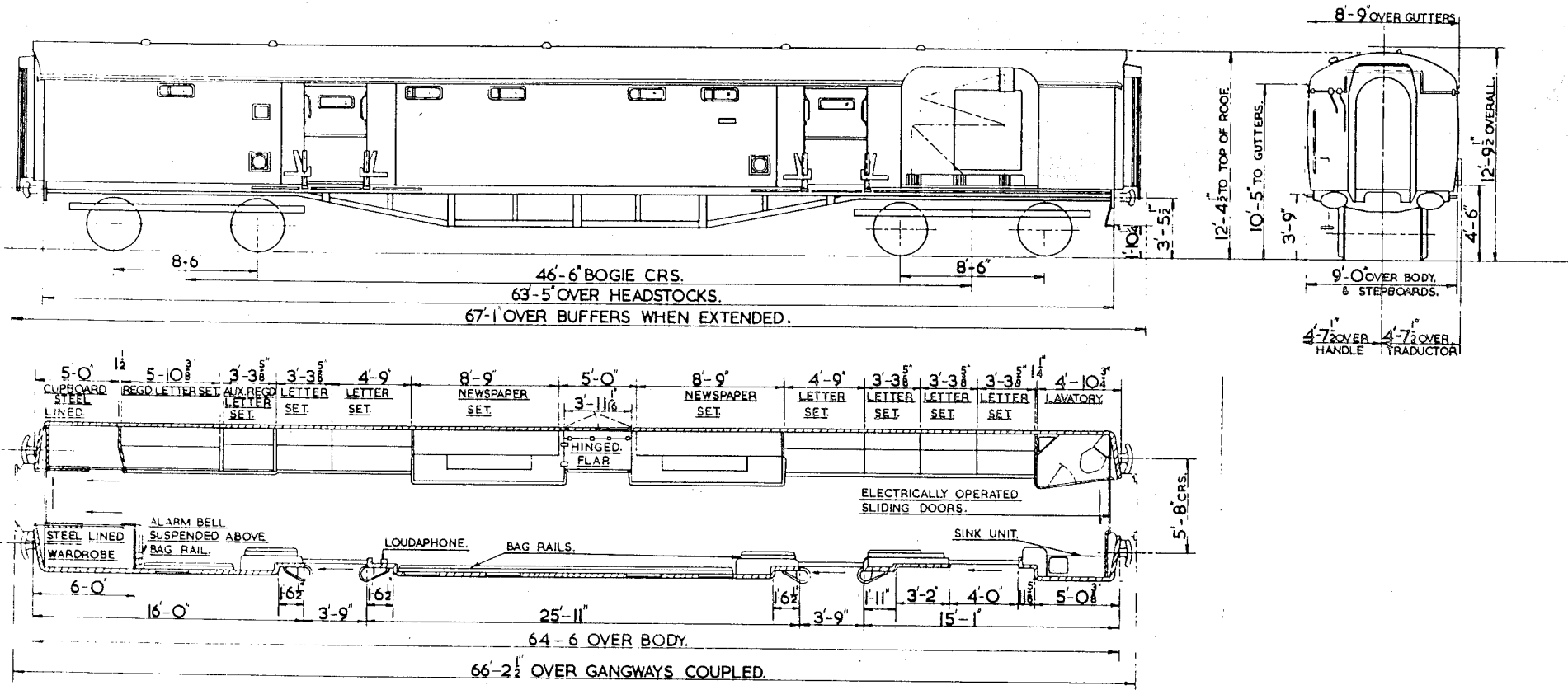

- SEATS -
- TOILETS -
- COMPARTMENTS -
- GUARDS COMPARTMENTS -
- VENTILATION -
- CATERING EQUIPMENT -
- PRESSURE -

ORIGINAL DIAGRAMS FOR REFERENCE.-
BR 729

ISSUE 2 DATE MAY '81

NS 505

BASIC TYPE

ALTERNATIVES

BRAKES
BOGIE/SUSPENSION
BODY CONSTRUCTION
COUPLINGS
TRAIN HEATING
E. T. H. INDEX
MAX. SPEED M. P. H.
MIN. RAD. CURVE CHAINS
LIGHTING
TARE WEIGHT TONNES
GANGWAYS
TRAIN COMMUNICATION
BUFFERS

VACUUM & AIR
85
STEEL
AUTOMATIC DROPHEAD (BUCKEYE)
DUAL (STEAM/ELECTRIC (BR)) WITH PRESSURE VENTILATION & HEATING
4
100
3.5
TUNGSTEN
35
PULLMAN
COACH/COACH LOUDAPHONE
RETRACTABLE SPINDLE-559 X 356 OVAL

TRACTION DATA FOR MULTIPLE UNITS

BASIC TYPE

NS 505 08

VARIANTS

NONE

POST OFFICE SORTING VAN-MK I

CLASS ---

POS

NS 506

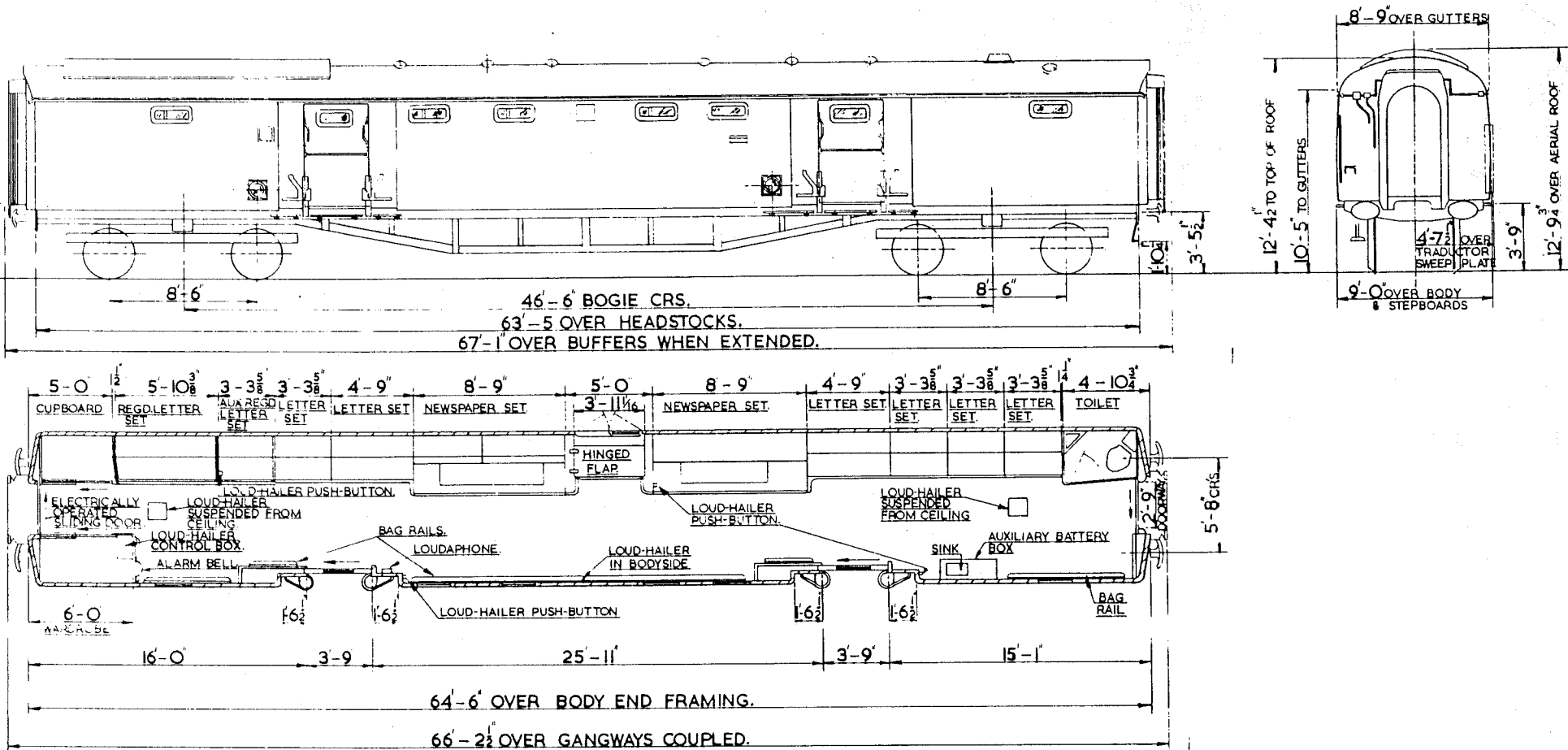

- SEATS -
- TOILETS - 1
- COMPARTMENTS -
- GUARDS COMPARTMENTS -
- VENTILATION -
- CATERING EQUIPMENT -
- PRESSURE -

ORIGINAL DIAGRAMS FOR REFERENCE.-
BR 731

ISSUE 2 DATE MAY '81

NS 506

BRAKES
BOGIE/SUSPENSION
BODY CONSTRUCTION
COUPLINGS
TRAIN HEATING
E.T.H. INDEX
MAX. SPEED M.P.H.
MIN. RAD. CURVE CHAINS
LIGHTING
TARE WEIGHT TONNES
GANGWAYS
TRAIN COMMUNICATION
BUFFERS

BASIC TYPE

VACUUM & AIR
85
STEEL
AUTOMATIC DROPHEAD (BUCKEYE)
DUAL (STEAM/ELECTRIC (BR)) WITH PRESSURE VENTILATION & HEATING
4
100
3.5
• TUNGSTEN
38
PULLMAN
COACH/COACH LOUDAPHONE-LOUD HAILER-PROVISION FOR RADIO
RETRACTABLE SPINDLE-559 X 356 OVAL

ALTERNATIVES

TRACTION DATA FOR MULTIPLE UNITS

BASIC TYPE

NS 506 0B

VARIANTS

NONE

POST OFFICE SORTING VAN-MK I

CLASS ----

POS

NS 531

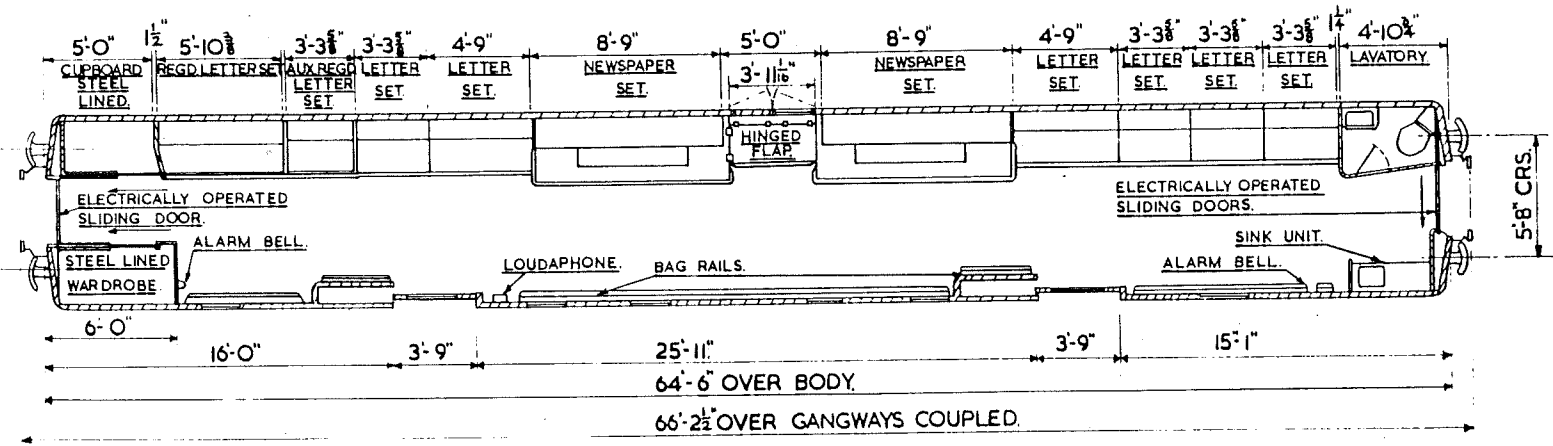
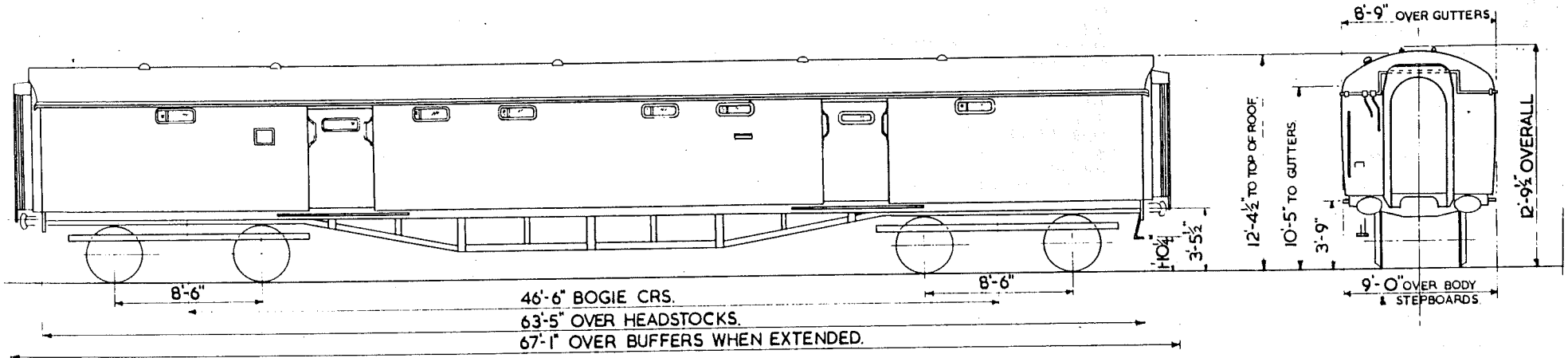

- SEATS -
- TOTILETS 1
- COMPARTMENTS -
- GUARDS COMPARTMENTS -
- VENTILATION PRESSURE
- CATERING EQUIPMENT -

ORIGINAL DIAGRAMS FOR REFERENCE.-
 BR 726A

ISSUE 1 DATE SEP '60

NS 531

BASIC TYPE

BRAKES
BOGIE/SUSPENSION
BODY CONSTRUCTION
COUPLINGS
TRAIN HEATING
E.T.H. INDEX
MAX. SPEED M.P.H.
MIN. RAD. CURVE CHAINS
LIGHTING
TARE WEIGHT TONNES
GANGWAYS
TRAIN COMMUNICATION
BUFFERS

VACUUM & AIR
B5
STEEL
AUTOMATIC DROPHEAD (BUCKEYE)
DUAL (STEAM/ELECTRIC (BR)) WITH PRESSURE VENTILATION & HEATING
4 PLUS 600 AMP WIRING
100
3.5
FLUORESCENT & TUNGSTEN
34.5
PULLMAN
COACH/COACH LOUDAPHONE
RETRACTABLE SPINDLE-559 X 356 OVAL

ALTERNATIVES

TRACTION DATA FOR MULTIPLE UNITS

BASIC TYPE

NS 531 0A

VARIANTS

NONE

POST OFFICE STOWAGE VAN-MK I

CLASS ----

POT

NT 501

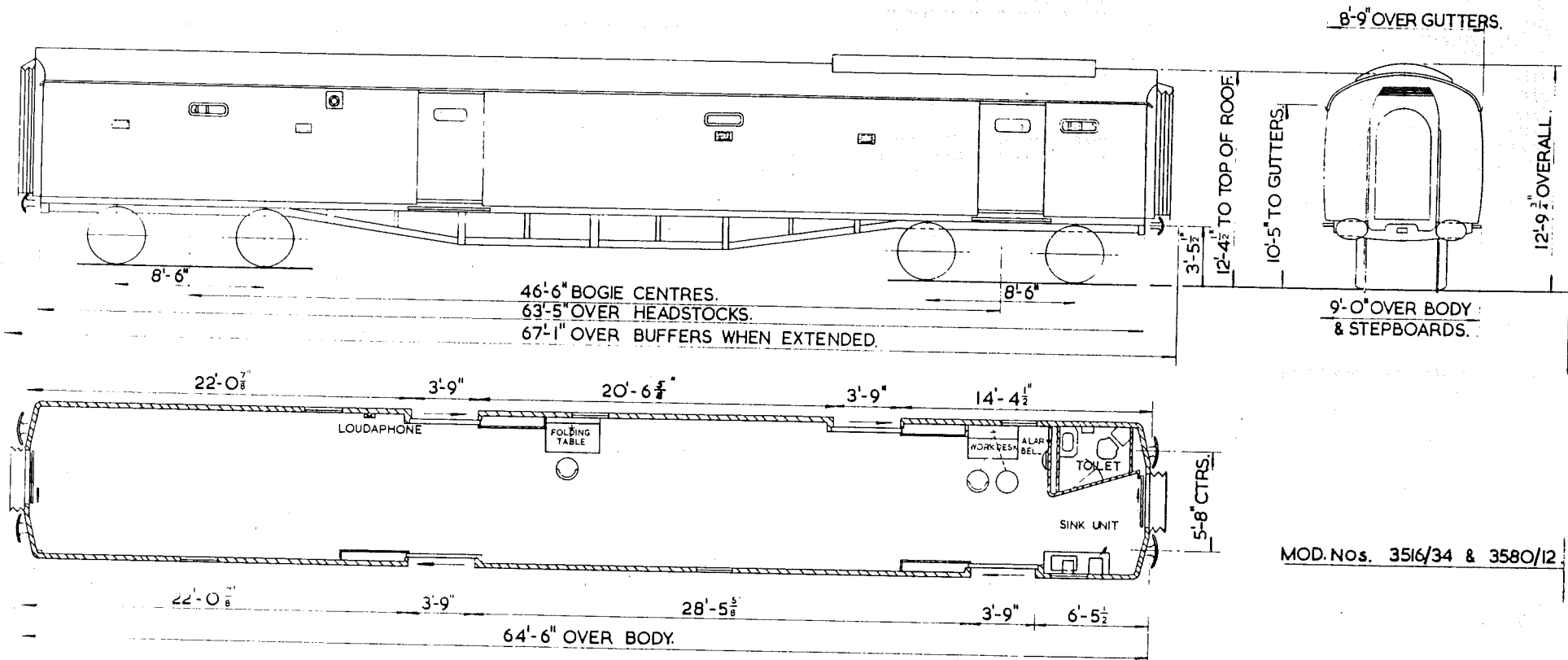

MOD. NOS. 3516/34 & 3580/12

- SEATS -
- TOILETS - 1
- COMPARTMENTS -
- GUARDS COMPARTMENTS -
- VENTILATION -
- CATERING EQUIPMENT -

ORIGINAL DIAGRAMS FOR REFERENCE.-
BR 724B

ISSUE 1 DATE SEP' 80

NT 501

BASIC TYPE

BRAKES
BOGIE/SUSPENSION
BODY CONSTRUCTION
COUPLINGS
TRAIN HEATING
E.T.H. INDEX
MAX. SPEED M.P.H.
MIN. RAD. CURVE CHAINS
LIGHTING
TARE WEIGHT TONNES
GANGWAYS
TRAIN COMMUNICATION
BUFFERS

VACUUM
BR STANDARD MK 2
STEEL
AUTOMATIC DROPHEAD (BUCKEYE)
DUAL (STEAM/ELECTRIC (BR))
3
90
3.5
ELECTRIC
38
PULLMAN
COACH/COACH LOUDPHONE
RETRACTABLE SPINDLE-559 X 356 OVAL

ALTERNATIVES

3 PLUS 600 AMP WIRING

TRACTION DATA FOR MULTIPLE UNITS

BASIC TYPE

NT 501 1A

VARIANTS

2A E.T.H. INDEX 3 PLUS 600 AMP WIRING.

POST OFFICE STOWAGE VAN-MK I

CLASS ---

POT

NT 502

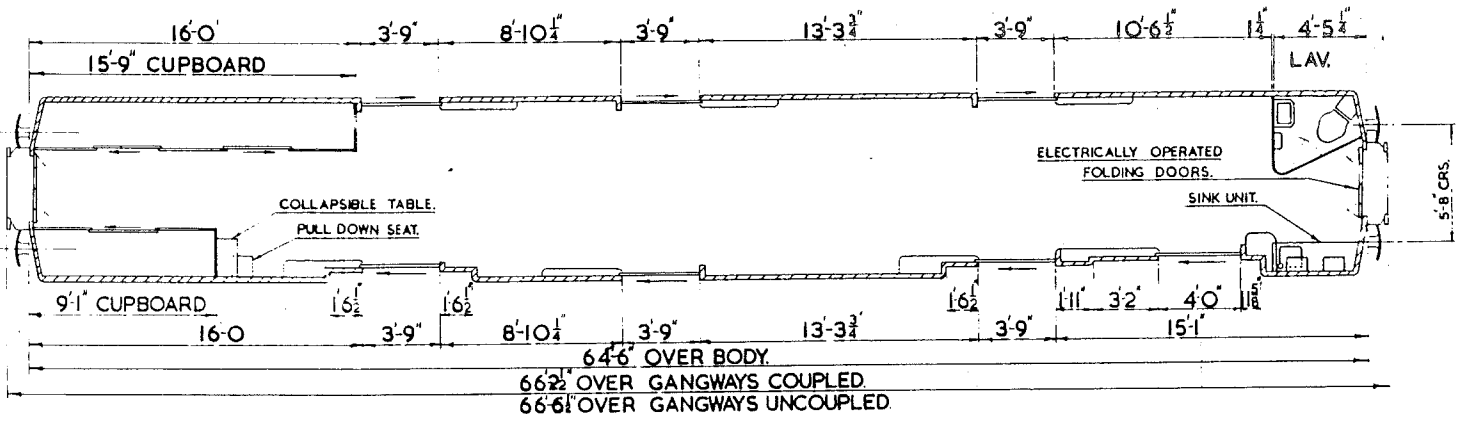
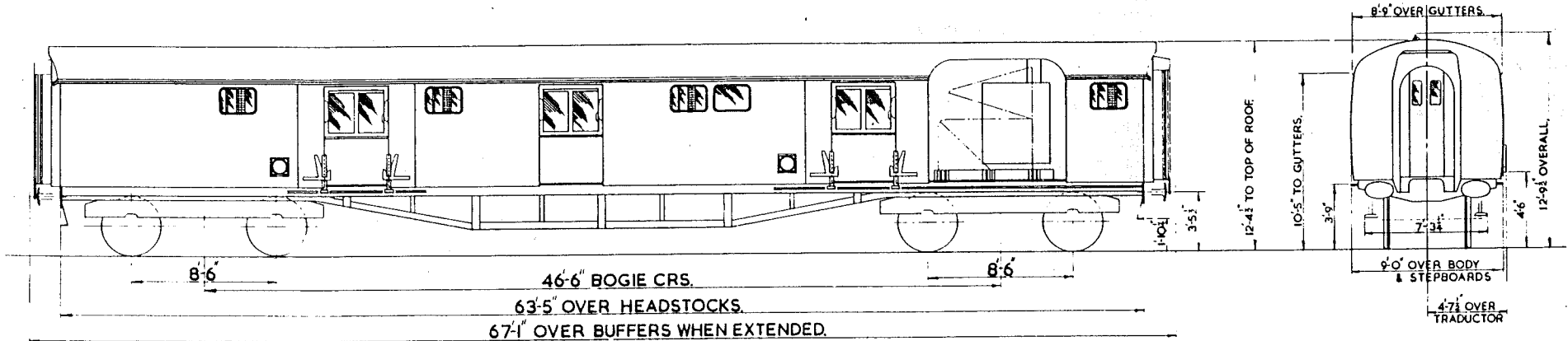

- SEATS -
- TOILETS - 1
- COMPARTMENTS -
- GUARDS COMPARTMENTS -
- VENTILATION -
- CATERING EQUIPMENT -

ORIGINAL DIAGRAMS FOR REFERENCE, -
BR 722

ISSUE 1 DATE SEP' 80

NT 502

BASIC TYPE

ALTERNATIVES

BRAKES
BOGIE/SUSPENSION
BODY CONSTRUCTION
COUPLINGS
TRAIN HEATING
E.T.H. INDEX
MAX. SPEED M.P.H.
MIN. RAD. CURVE CHAINS
LIGHTING
TARE VEIGHT TONNES
GANGWAYS
TRAIN COMMUNICATION
BUFFERS

VACUUM & AIR
B5
STEEL
AUTOMATIC DROPHEAD (BUCKEYE)
DUAL (STEAM/ELECTRIC (BR))
3
90
3.5
ELECTRIC
35
PULLMAN
NOT FITTED
RETRACTABLE SPINDLE-559 X 356 OVAL

TRACTION DATA FOR MULTIPLE UNITS

BASIC TYPE

NT 502 0A

VARIANTS

NONE

POST OFFICE STOWAGE VAN-MK I

CLASS ---

POT

NT 503

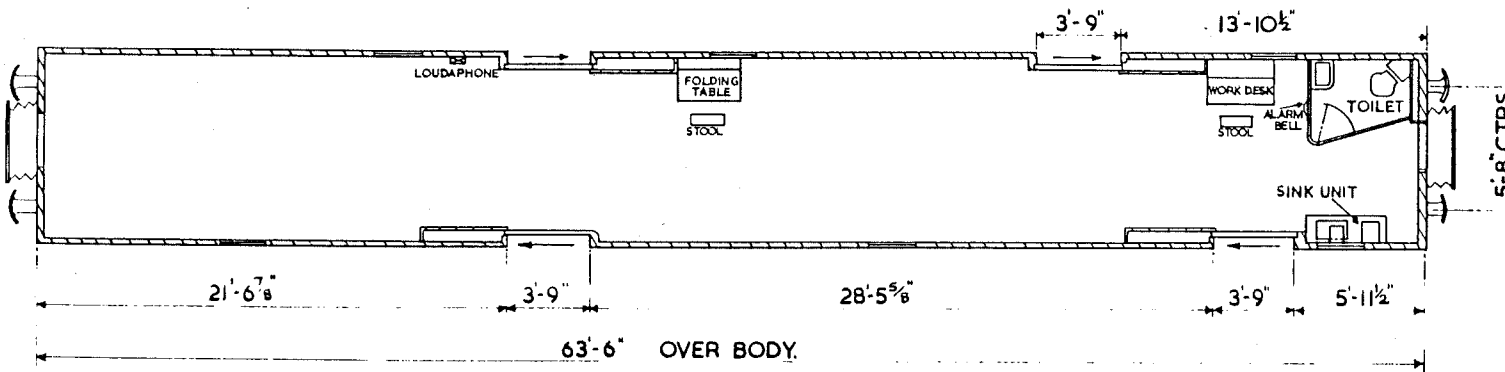
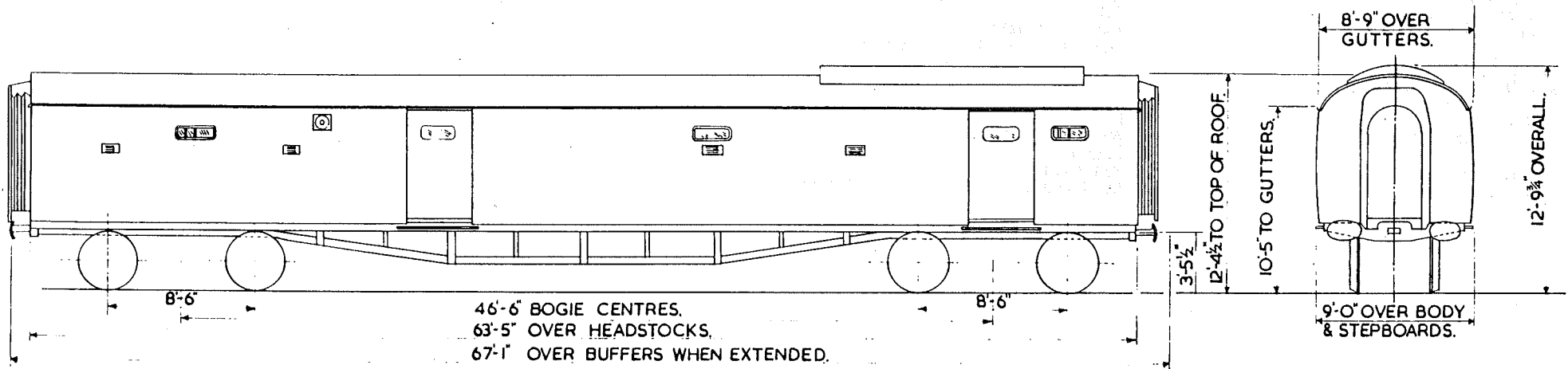

- SEATS -
- TOILETS 1
- COMPARTMENTS -
- GUARDS COMPARTMENTS -
- VENTILATION -
- CATERING EQUIPMENT -

ORIGINAL DIAGRAMS FOR REFERENCE -
BR 725A

ISSUE 1 DATE SEP '80

NT 503

BASIC TYPE

ALTERNATIVES

BRAKES
BOGIE/SUSPENSION
BODY CONSTRUCTION
COUPLINGS
TRAIN HEATING
E. T. H. INDEX
MAX. SPEED M. P. H.
MIN. RAD. CURVE CHAINS
LIGHTING
TARE VEIGHT TONNES
GANGWAYS
TRAIN COMMUNICATION
BUFFERS

VACUUM & AIR
B5
STEEL
AUTOMATIC DROPHEAD (BUCKEYE)
DUAL (STEAM/ELECTRIC (BR))
3
90
3.5
ELECTRIC
35
PULLMAN
NOT FITTED
RETRACTABLE SPINDLE-559 X 356 OVAL

3 PLUS 600 AMP WIRING

TRACTION DATA FOR MULTIPLE UNITS

BASIC TYPE

NT 503 1A

VARIANTS

2A E. T. H. INDEX 3 PLUS 600 AMP WIRING.

POST OFFICE STORAGE VAN-MK I

CLASS ---

POT

NT 504

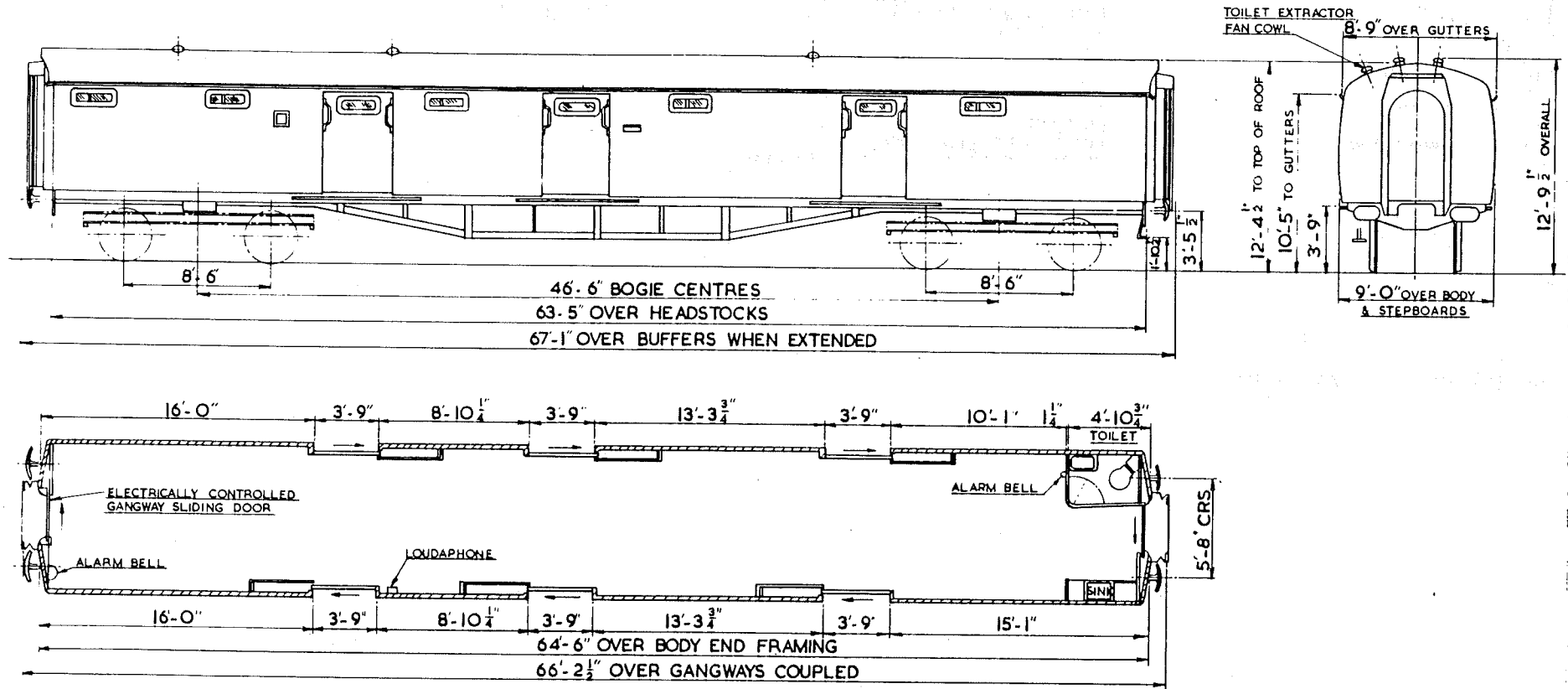

- SEATS -
- TOILETS - 1
- COMPARTMENTS -
- GUARDS COMPARTMENTS -
- VENTILATION - PRESSURE
- CATERING EQUIPMENT -

ORIGINAL DIAGRAMS FOR REFERENCE.-
BR 727A

ISSUE 1 DATE SEP' 80

NT 504

BRAKES
BOGIE/SUSPENSION
BODY CONSTRUCTION
COUPLINGS
TRAIN HEATING
E.T.H. INDEX
MAX. SPEED M.P.H.
MIN. RAD. CURVE CHAINS
LIGHTING
TARE WEIGHT TONNES
GANGWAYS
TRAIN COMMUNICATION
BUFFERS

BASIC TYPE

VACUUM & AIR
85
STEEL
AUTOMATIC DROPHEAD (BUCKEYE)
DUAL (STEAM/ELECTRIC (BR)) WITH PRESSURE VENTILATION & HEATING
4 PLUS 600 AMP WIRING
100
3.5
FLUORESCENT & TUNGSTEN
35
PULLMAN
COACH/COACH LOUDAPHONE
RETRACTABLE SPINDLE-559 X 356 OVAL

ALTERNATIVES

TRACTION DATA FOR MULTIPLE UNITS

BASIC TYPE

NT 504 OA

VARIANTS

NONE

POST OFFICE STOWAGE VAN-MK I

CLASS ---

POT

NT 505

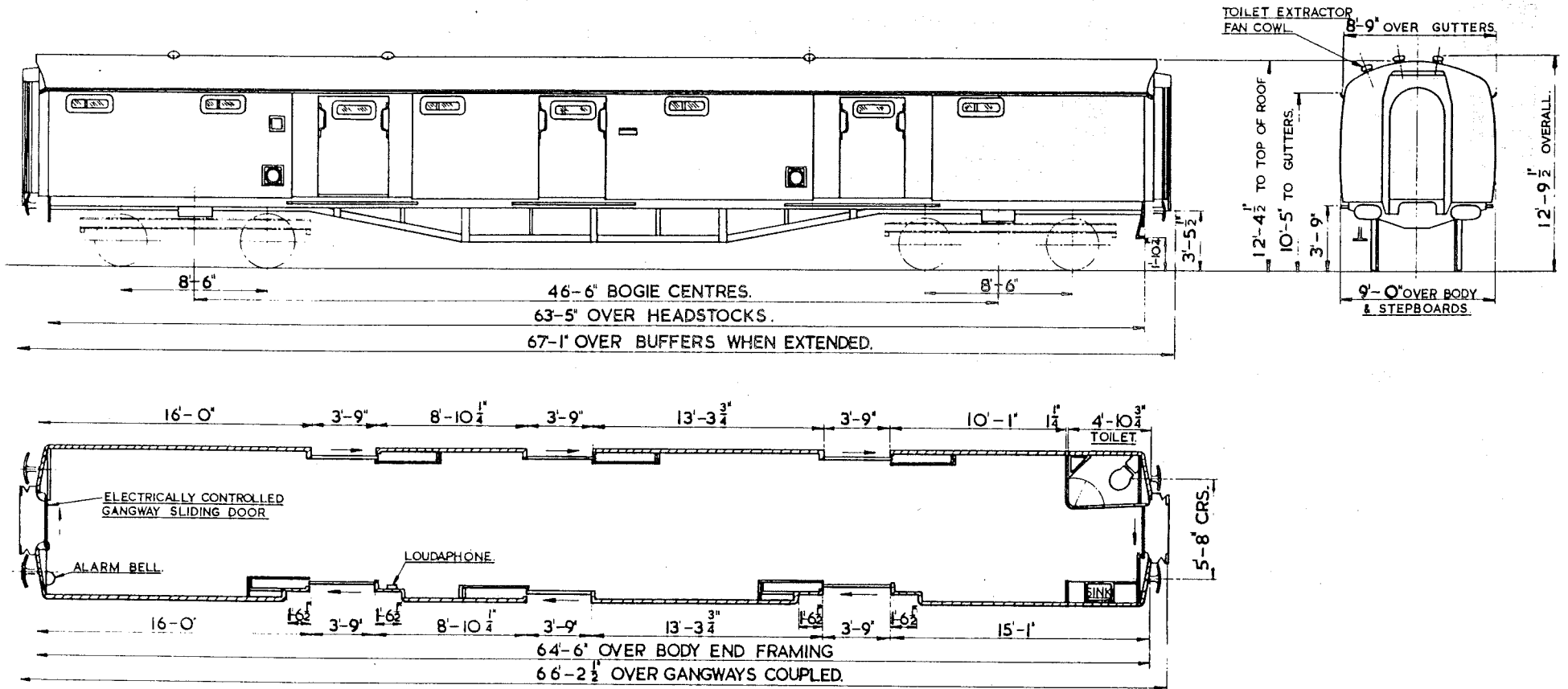

- SEATS -
- TOILETS - 1
- COMPARTMENTS -
- GUARDS COMPARTMENTS -
- VENTILATION - PRESSURE
- CATERING EQUIPMENT -

ORIGINAL DIAGRAMS FOR REFERENCE.-
BR 732

ISSUE 1 DATE SEP' 80

NT 505

BASIC TYPE

ALTERNATIVES

BRAKES
BOGIE/SUSPENSION
BODY CONSTRUCTION
COUPLINGS
TRAIN HEATING
E.T.H. INDEX
MAX. SPEED M.P.H.
MIN. RAD. CURVE CHAINS
LIGHTING
TARE WEIGHT TONNES
GANGWAYS
TRAIN COMMUNICATION
BUFFERS

VACUUM & AIR
B5
STEEL
AUTOMATIC DROPHEAD (BUCKEYE)
DUAL (STEAM/ELECTRIC (BR)) WITH PRESSURE VENTILATION & HEATING
4
100
3.5
ELECTRIC
34
PULLMAN
COACH/COACH LOUDAPHONE
RETRACTABLE SPINDLE-559 X 356 OVAL

TRACTION DATA FOR MULTIPLE UNITS

BASIC TYPE

NT 505 0A

VARIANTS

NONE

POST OFFICE STOWAGE VAN-MK I

CLASS ---

POT

NT 521

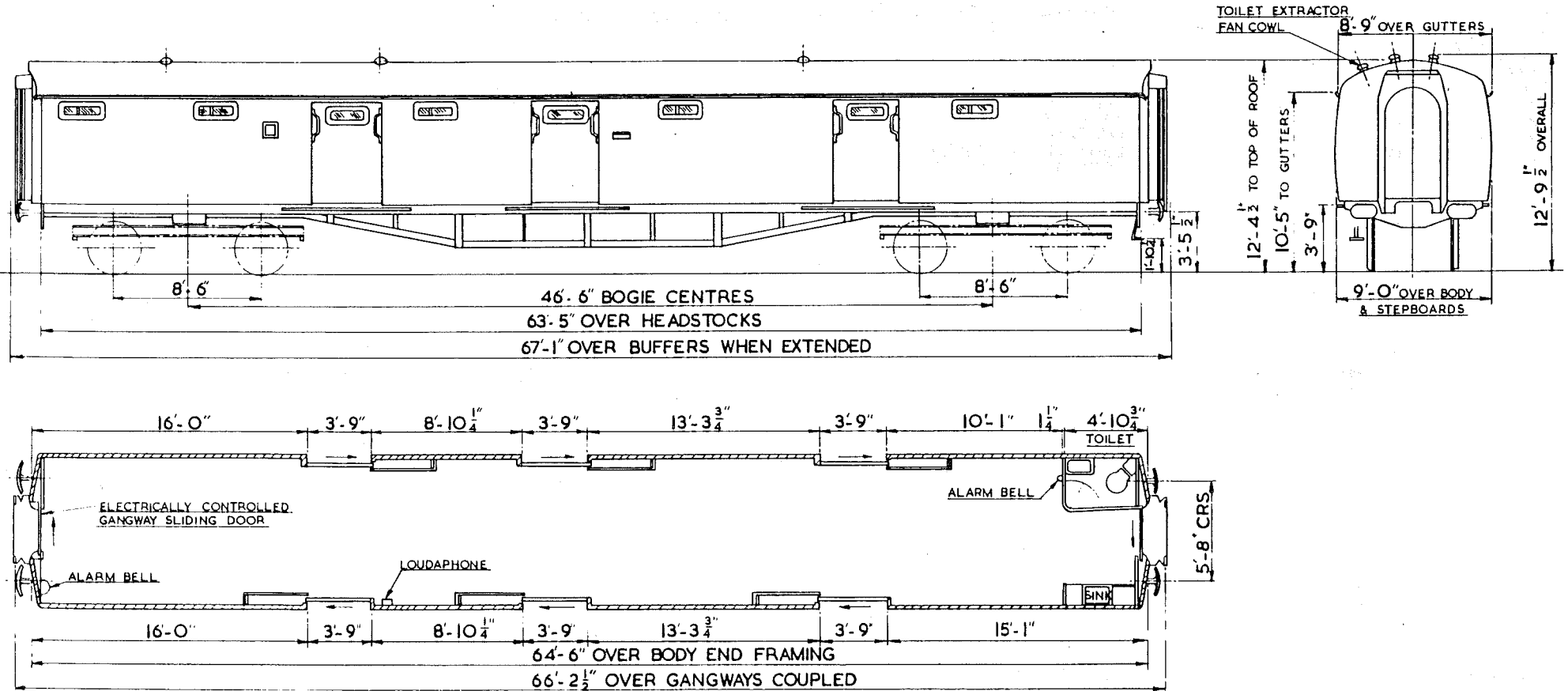

- SEATS -
- TOILETS 1
- COMPARTMENTS -
- GUARDS COMPARTMENTS -
- VENTILATION -
- CATERING EQUIPMENT -
- PRESSURE -

ORIGINAL DIAGRAMS FOR REFERENCE.-
BR 727A

ISSUE 1 DATE SEP' 80

NT 521

BASIC TYPE

ALTERNATIVES

BRAKES
BOGIE/SUSPENSION
BODY CONSTRUCTION
COUPLINGS
TRAIN HEATING
E.T.H. INDEX
MAX. SPEED M.P.H.
MIN. RAD. CURVE CHAINS
LIGHTING
TARE WEIGHT TONNES
GANGWAYS
TRAIN COMMUNICATION
BUFFERS

VACUUM & AIR
B5
STEEL
AUTOMATIC DROPHEAD (BUCKEYE)
DUAL (STEAM/ELECTRIC (BR)) WITH PRESSURE VENTILATION & HEATING
4 PLUS 600 AMP VIRING
100
3.5
ELECTRIC
34.5
PULLMAN
COACH/COACH LOUDAPHONE
RETRACTABLE SPINDLE-559 X 356 OVAL

TRACTION DATA FOR MULTIPLE UNITS

BASIC TYPE

NT 521 OA

VARIANTS

NONE

POSTAL BRAKE VAN-MK I

CLASS ---

POTB

NU 501

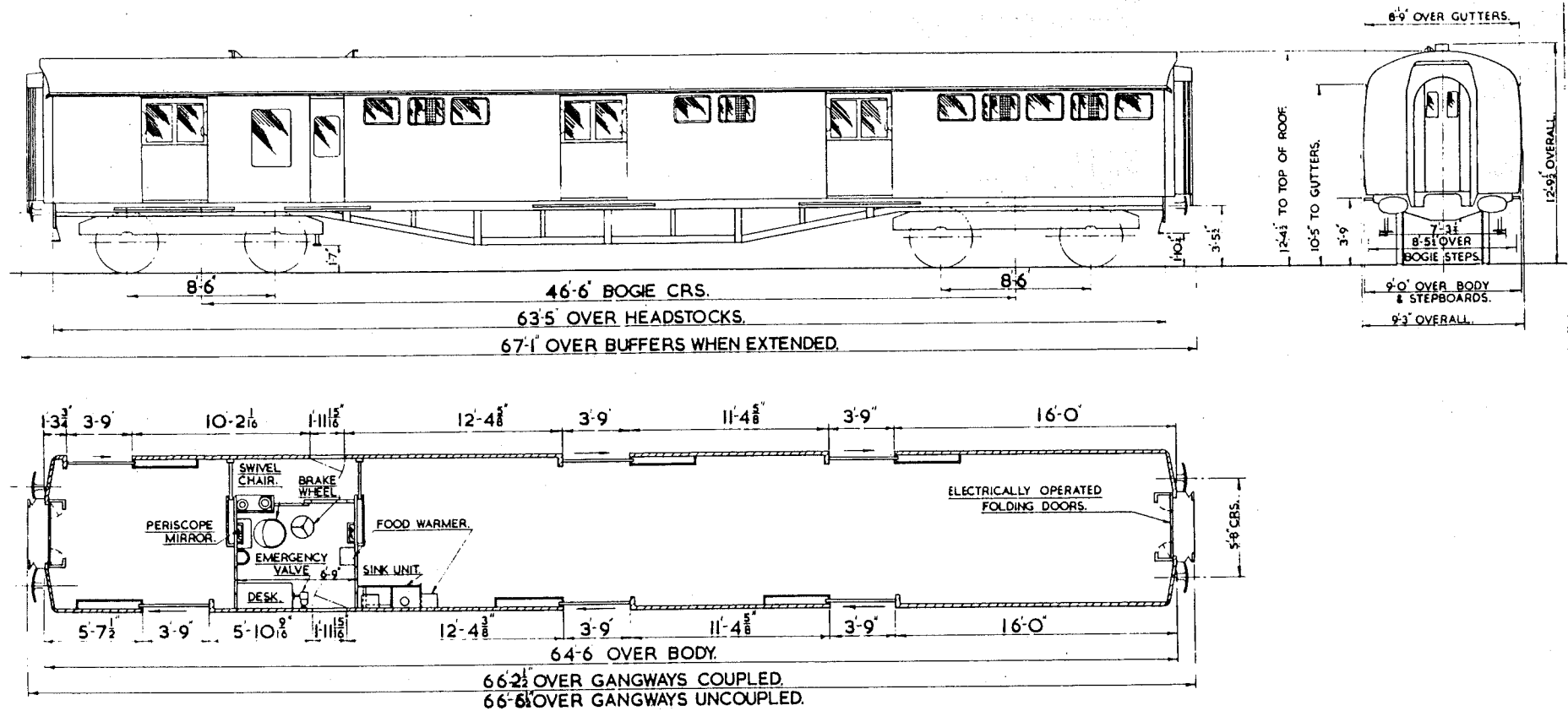

- SEATS -
- TOILETS -
- COMPARTMENTS -
- GUARDS COMPARTMENTS 1
- VENTILATION -
- CATERING EQUIPMENT -
- ELECTRIC -

ORIGINAL DIAGRAMS FOR REFERENCE.-
BR 723

ISSUE 1 DATE SEP '80

NU 501

BASIC TYPE

ALTERNATIVES

BRAKES
BOGIE/SUSPENSION
BODY CONSTRUCTION
COUPLINGS
TRAIN HEATING
E.T.H. INDEX
MAX. SPEED M.P.H.
MIN. RAD. CURVE CHAINS
LIGHTING
TARE WEIGHT TONNES
GANGWAYS
TRAIN COMMUNICATION
BUFFERS

VACUUM
BR STANDARD MK 2
STEEL
AUTOMATIC DROPHEAD (BUCKEY)
DUAL (STEAM/ELECTRIC (BR))
3 PLUS 600 AMP WIRING
90
3.5
ELECTRIC
34
PULLMAN
NOT FITTED
RETRACTABLE SPINDLE-559 X 356 OVAL

TRACTION DATA FOR MULTIPLE UNITS

BASIC TYPE

NU 501 1A

VARIANTS

NONE

POSTAL BRAKE VAN-MK I

CLASS ----

POTB

NU 502

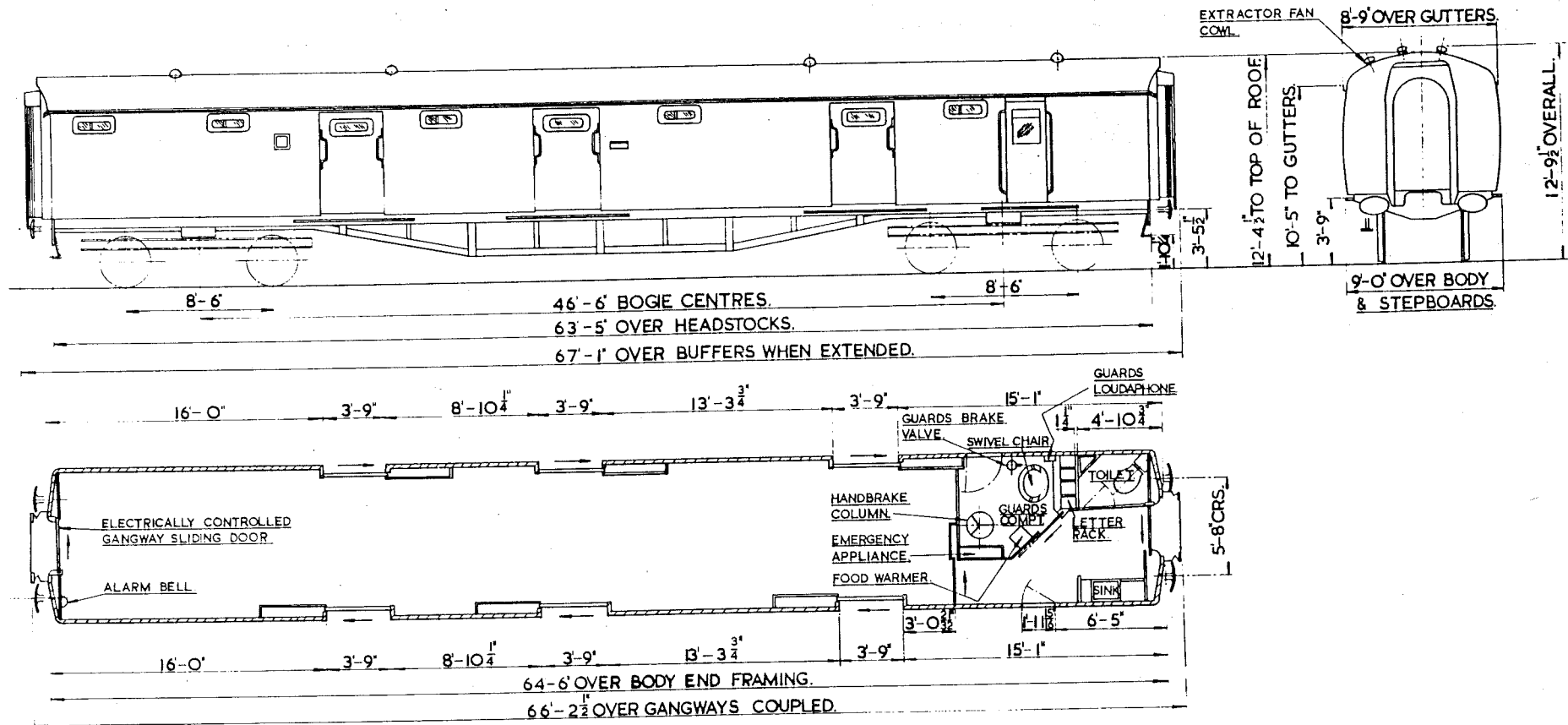

- SEATS -
- TOILETS 1
- COMPARTMENTS -
- GUARDS COMPARTMENTS 1
- VENTILATION PRESSURE
- CATERING EQUIPMENT ELECTRIC

ORIGINAL DIAGRAMS FOR REFERENCE--
BR 733

ISSUE 1 DATE SEP '80

NU 502

BRAKES
 BOGIE/SUSPENSION
 BODY CONSTRUCTION
 COUPLINGS
 TRAIN HEATING
 E. T. H. INDEX
 MAX. SPEED M. P. H.
 MIN. RAD. CURVE CHAINS
 LIGHTING
 TARE WEIGHT TONNES
 GANGWAYS
 TRAIN COMMUNICATION
 BUFFERS

BASIC TYPE

VACUUM & AIR
 B5
 STEEL
 AUTOMATIC DROPHEAD (BUCKEYE)
 DUAL (STEAM/ELECTRIC (BR)) WITH PRESSURE VENTILATION & HEATING
 4
 100
 3.5
 ELECTRIC
 32
 PULLMAN
 NOT FITTED
 RETRACTABLE SPINDLE-559 X 356 OVAL

ALTERNATIVES

TRACTION DATA FOR MULTIPLE UNITS

BASIC TYPE

NU 502 0A

VARIANTS

NONE

SIDE LOADING MOTORAIL VEHICLE

YX 068 A

LOT No.	
3102	
3192	

TOPS INFORMATION											
AARKND		OPERATING		MAX. OPERATING SPEED			BRAKE FORCE DATA		EXCESS LENGTH	RA (GLW)	DESIGN SHEET
CARKND		PANEL No.		40 mlie/h			8.75 †		7	1	W 2548 W 2549
Y	X	A	R								

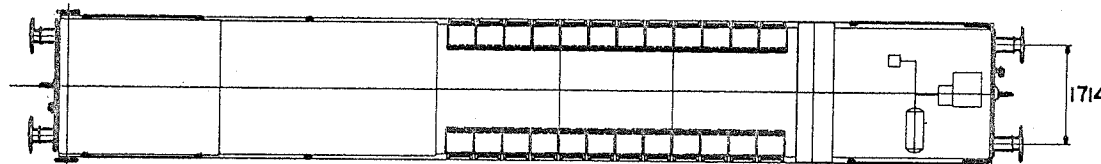
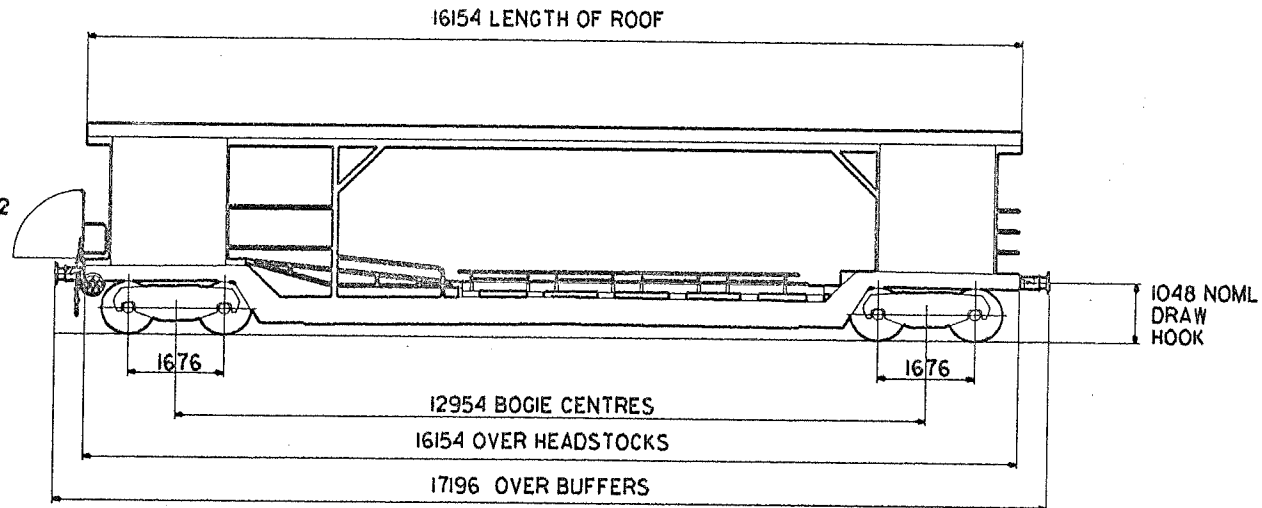
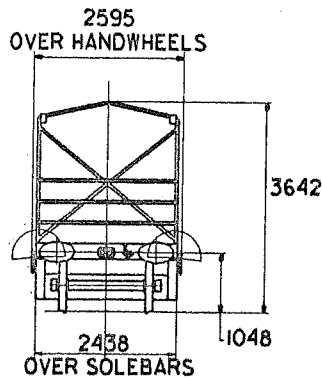

TARE-	24000 Kg
CAPACITY WEIGHT -	—————
CAPACITY VOLUME -	—————
MIN.CURVE -	90 m
GEN.ARRGT.DRG.No.-	SI - A0 - 8004332

BRAKE -	AIR BRAKE (ONE BOGIE) & HAND SCREW
SUSPENSION -	SECONDARY COIL
COUPLINGS -	BR SCREW
BUFFERS -	SELF CONTAINED (610x356) OVAL HEADS
WHEELS -	952 DIA.
JOURNALS -	III DIA ROLLER BEARINGS

ISSUE DATE
1 2/91

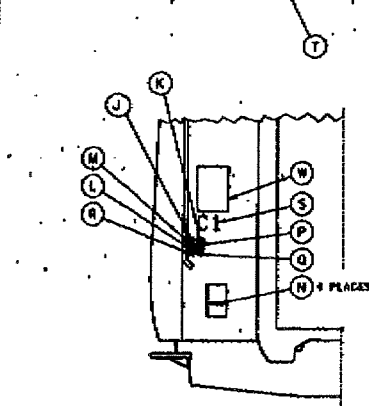
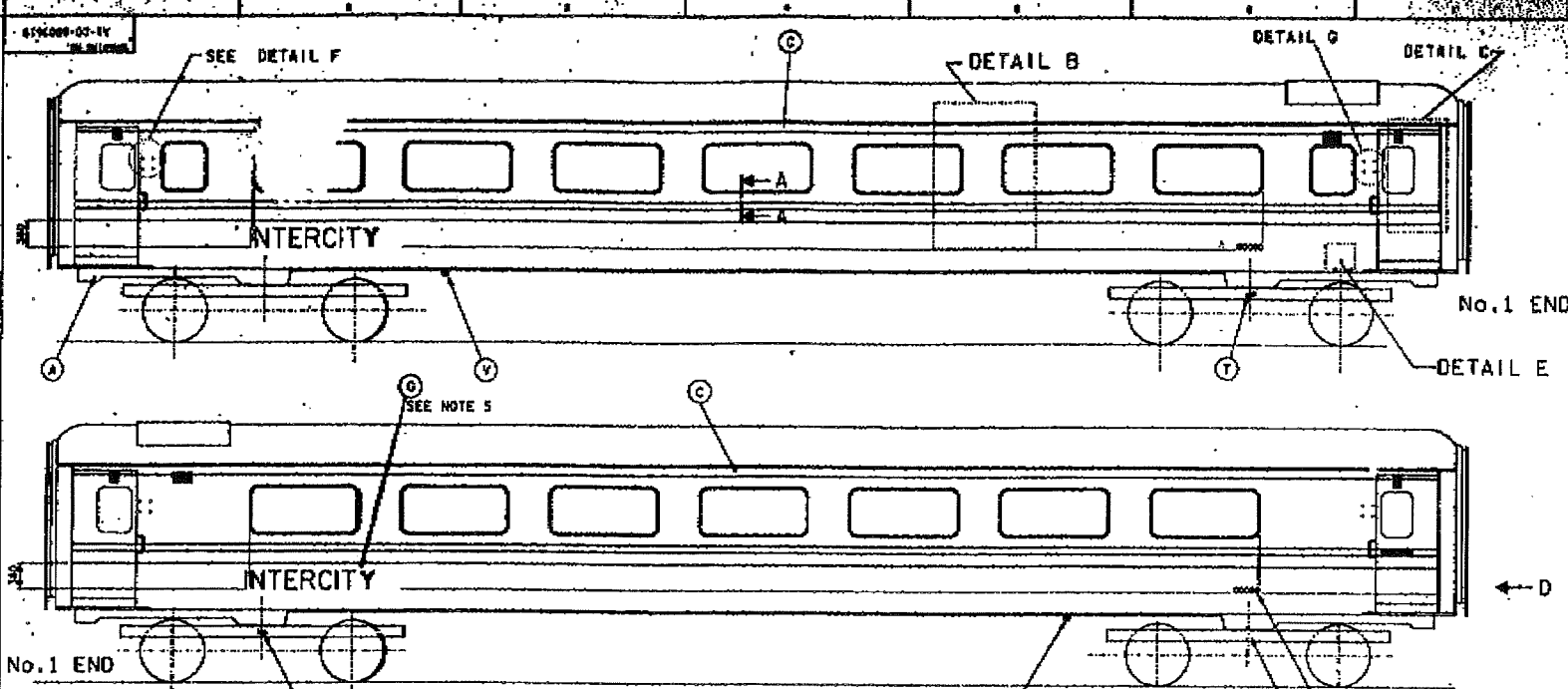

AS SHOWN & DIAGONALLY OPPOSITE CORNER
VIEW ON ARROW D

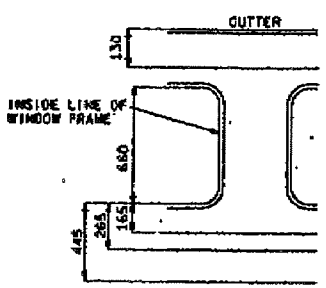

DETAIL B

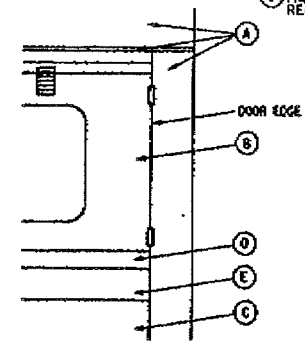

DETAIL C

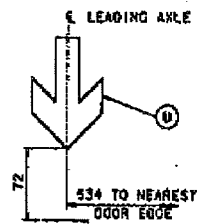

No. 1 WHEEL IDENTIFICATION (No. 1 END) SEE E.I.No. NC/174

DETAIL E

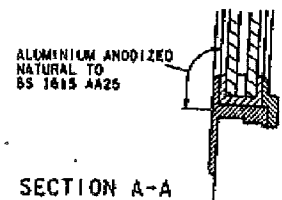

SECTION A-A

- NOTES**
- EXTERNAL MARKINGS MATERIAL/PRESPECED, DIE-CUT SELF ADHESIVE PLASTIC SHEET FILM TO BR SPECIFICATION 63 COLOUR AS LISTED
 - VEHICLE TO BE PAINTED IN ACCORDANCE WITH CODE OF PRACTICE 60/LHC/TS/68-25
 - PAINTS TO BE TO BR SPEC. 61, UNLESS OTHERWISE STATED
 - LIVERY TO BE TAKEN AROUND BODY ENDS TO EDGE OF DOOR
 - POSITIONED AS SHOWN AND DIAGONALLY OPPOSITE

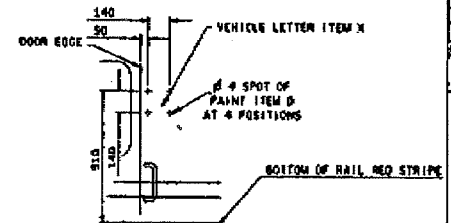

DETAIL F (TYPICAL 2 POSITIONS)
DETAIL G (TYPICAL 2 POSITIONS)

UNLESS OTHERWISE STATED:
MATERIALS - TO BE IN ACCORDANCE WITH BR SPECIFICATION AND PLATE INDICATIONS - IF ANY QTY. COLOUR CODES NUMBER SHALL BE IN ACCORDANCE WITH BR SPECIFICATION 61.
DIMENSIONS - TO REMAIN UNLESS OTHERWISE STATED AND TO BE AFFIXED TO THE DRAWING BY THE DRAWING OFFICE. DIMENSIONS IN THE DRAWING OF THE DRAWING OFFICE SHALL BE USED FOR THE PURPOSES OF THE DRAWING OFFICE.
DIMENSIONS TO BE ACCORDANCE WITH BR SPECIFICATION 61.
ALL DIMENSIONS TO BE IN MILLIMETRES.

THIS DRAWING IS AN INSTRUMENTAL DRAWING AND NOT A CONTRACT DOCUMENT. IT IS NOT TO BE USED FOR THE PURPOSES OF A CONTRACT. IT IS THE RESPONSIBILITY OF THE CONTRACTOR TO OBTAIN ALL NECESSARY INFORMATION FROM THE DRAWING OFFICE AND TO OBTAIN ALL NECESSARY INFORMATION FROM THE CONTRACT DOCUMENTS.

20 MAR '92 15:04 FROM INTERCITY MAINTENANCE

**DRAWING SUPPLY BUREAU
R.T.C. DERBY
UNCONTROLLED DRAWING
FOR REFERENCE ONLY**

4	C	DOOR LETTER	SHOWN TO		
2	B	DATA POINT	SHOWN TO		
2	Y	STAR	SEE NOTE 5		
1	U	ARMOUR	SHOWN TO		
2	T	PL. END STRIP	SHOWN TO		
2	Z	CL. FRAME	SHOWN TO		
1	W	REPAIR PLATE	SHOWN TO		
1	V	DATA	SEE NOTE 5		
1	Q	LIFTING PIN	SHOWN TO		
4	P	TRAP FILLER	SHOWN TO		
2	H	LIFTING PIN	SHOWN TO		
2	G	LIFTING PIN	SHOWN TO		
2	F	LIFTING PIN	SHOWN TO		
2	E	LIFTING PIN	SHOWN TO		
2	D	LIFTING PIN	SHOWN TO		
2	C	LIFTING PIN	SHOWN TO		
2	B	LIFTING PIN	SHOWN TO		
2	A	LIFTING PIN	SHOWN TO		
2	Z	LIFTING PIN	SHOWN TO		
2	Y	LIFTING PIN	SHOWN TO		
2	X	LIFTING PIN	SHOWN TO		
2	W	LIFTING PIN	SHOWN TO		
2	V	LIFTING PIN	SHOWN TO		
2	U	LIFTING PIN	SHOWN TO		
2	T	LIFTING PIN	SHOWN TO		
2	S	LIFTING PIN	SHOWN TO		
2	R	LIFTING PIN	SHOWN TO		
2	Q	LIFTING PIN	SHOWN TO		
2	P	LIFTING PIN	SHOWN TO		
2	O	LIFTING PIN	SHOWN TO		
2	N	LIFTING PIN	SHOWN TO		
2	M	LIFTING PIN	SHOWN TO		
2	L	LIFTING PIN	SHOWN TO		
2	K	LIFTING PIN	SHOWN TO		
2	J	LIFTING PIN	SHOWN TO		
2	I	LIFTING PIN	SHOWN TO		
2	H	LIFTING PIN	SHOWN TO		
2	G	LIFTING PIN	SHOWN TO		
2	F	LIFTING PIN	SHOWN TO		
2	E	LIFTING PIN	SHOWN TO		
2	D	LIFTING PIN	SHOWN TO		
2	C	LIFTING PIN	SHOWN TO		
2	B	LIFTING PIN	SHOWN TO		
2	A	LIFTING PIN	SHOWN TO		
2	Z	LIFTING PIN	SHOWN TO		
2	Y	LIFTING PIN	SHOWN TO		
2	X	LIFTING PIN	SHOWN TO		
2	W	LIFTING PIN	SHOWN TO		
2	V	LIFTING PIN	SHOWN TO		
2	U	LIFTING PIN	SHOWN TO		
2	T	LIFTING PIN	SHOWN TO		
2	S	LIFTING PIN	SHOWN TO		
2	R	LIFTING PIN	SHOWN TO		
2	Q	LIFTING PIN	SHOWN TO		
2	P	LIFTING PIN	SHOWN TO		
2	O	LIFTING PIN	SHOWN TO		
2	N	LIFTING PIN	SHOWN TO		
2	M	LIFTING PIN	SHOWN TO		
2	L	LIFTING PIN	SHOWN TO		
2	K	LIFTING PIN	SHOWN TO		
2	J	LIFTING PIN	SHOWN TO		
2	I	LIFTING PIN	SHOWN TO		
2	H	LIFTING PIN	SHOWN TO		
2	G	LIFTING PIN	SHOWN TO		
2	F	LIFTING PIN	SHOWN TO		
2	E	LIFTING PIN	SHOWN TO		
2	D	LIFTING PIN	SHOWN TO		
2	C	LIFTING PIN	SHOWN TO		
2	B	LIFTING PIN	SHOWN TO		
2	A	LIFTING PIN	SHOWN TO		
2	Z	LIFTING PIN	SHOWN TO		
2	Y	LIFTING PIN	SHOWN TO		
2	X	LIFTING PIN	SHOWN TO		
2	W	LIFTING PIN	SHOWN TO		
2	V	LIFTING PIN	SHOWN TO		
2	U	LIFTING PIN	SHOWN TO		
2	T	LIFTING PIN	SHOWN TO		
2	S	LIFTING PIN	SHOWN TO		
2	R	LIFTING PIN	SHOWN TO		
2	Q	LIFTING PIN	SHOWN TO		
2	P	LIFTING PIN	SHOWN TO		
2	O	LIFTING PIN	SHOWN TO		
2	N	LIFTING PIN	SHOWN TO		
2	M	LIFTING PIN	SHOWN TO		
2	L	LIFTING PIN	SHOWN TO		
2	K	LIFTING PIN	SHOWN TO		
2	J	LIFTING PIN	SHOWN TO		
2	I	LIFTING PIN	SHOWN TO		
2	H	LIFTING PIN	SHOWN TO		
2	G	LIFTING PIN	SHOWN TO		
2	F	LIFTING PIN	SHOWN TO		
2	E	LIFTING PIN	SHOWN TO		
2	D	LIFTING PIN	SHOWN TO		
2	C	LIFTING PIN	SHOWN TO		
2	B	LIFTING PIN	SHOWN TO		
2	A	LIFTING PIN	SHOWN TO		
2	Z	LIFTING PIN	SHOWN TO		
2	Y	LIFTING PIN	SHOWN TO		
2	X	LIFTING PIN	SHOWN TO		
2	W	LIFTING PIN	SHOWN TO		
2	V	LIFTING PIN	SHOWN TO		
2	U	LIFTING PIN	SHOWN TO		
2	T	LIFTING PIN	SHOWN TO		
2	S	LIFTING PIN	SHOWN TO		
2	R	LIFTING PIN	SHOWN TO		
2	Q	LIFTING PIN	SHOWN TO		
2	P	LIFTING PIN	SHOWN TO		
2	O	LIFTING PIN	SHOWN TO		
2	N	LIFTING PIN	SHOWN TO		
2	M	LIFTING PIN	SHOWN TO		
2	L	LIFTING PIN	SHOWN TO		
2	K	LIFTING PIN	SHOWN TO		
2	J	LIFTING PIN	SHOWN TO		
2	I	LIFTING PIN	SHOWN TO		
2	H	LIFTING PIN	SHOWN TO		
2	G	LIFTING PIN	SHOWN TO		
2	F	LIFTING PIN	SHOWN TO		
2	E	LIFTING PIN	SHOWN TO		
2	D	LIFTING PIN	SHOWN TO		
2	C	LIFTING PIN	SHOWN TO		
2	B	LIFTING PIN	SHOWN TO		
2	A	LIFTING PIN	SHOWN TO		
2	Z	LIFTING PIN	SHOWN TO		
2	Y	LIFTING PIN	SHOWN TO		
2	X	LIFTING PIN	SHOWN TO		
2	W	LIFTING PIN	SHOWN TO		
2	V	LIFTING PIN	SHOWN TO		
2	U	LIFTING PIN	SHOWN TO		
2	T	LIFTING PIN	SHOWN TO		
2	S	LIFTING PIN	SHOWN TO		
2	R	LIFTING PIN	SHOWN TO		
2	Q	LIFTING PIN	SHOWN TO		
2	P	LIFTING PIN	SHOWN TO		
2	O	LIFTING PIN	SHOWN TO		
2	N	LIFTING PIN	SHOWN TO		
2	M	LIFTING PIN	SHOWN TO		
2	L	LIFTING PIN	SHOWN TO		
2	K	LIFTING PIN	SHOWN TO		
2	J	LIFTING PIN	SHOWN TO		
2	I	LIFTING PIN	SHOWN TO		
2	H	LIFTING PIN	SHOWN TO		
2	G	LIFTING PIN	SHOWN TO		
2	F	LIFTING PIN	SHOWN TO		
2	E	LIFTING PIN	SHOWN TO		
2	D	LIFTING PIN	SHOWN TO		
2	C	LIFTING PIN	SHOWN TO		
2	B	LIFTING PIN	SHOWN TO		
2	A	LIFTING PIN	SHOWN TO		
2	Z	LIFTING PIN	SHOWN TO		
2	Y	LIFTING PIN	SHOWN TO		
2	X	LIFTING PIN	SHOWN TO		
2	W	LIFTING PIN	SHOWN TO		
2	V	LIFTING PIN	SHOWN TO		
2	U	LIFTING PIN	SHOWN TO		
2	T	LIFTING PIN	SHOWN TO		
2	S	LIFTING PIN	SHOWN TO		
2	R	LIFTING PIN	SHOWN TO		
2	Q	LIFTING PIN	SHOWN TO		
2	P	LIFTING PIN	SHOWN TO		
2	O	LIFTING PIN	SHOWN TO		
2	N	LIFTING PIN	SHOWN TO		
2	M	LIFTING PIN	SHOWN TO		
2	L	LIFTING PIN	SHOWN TO		
2	K	LIFTING PIN	SHOWN TO		
2	J	LIFTING PIN	SHOWN TO		
2	I	LIFTING PIN	SHOWN TO		
2	H	LIFTING PIN	SHOWN TO		
2	G	LIFTING PIN	SHOWN TO		
2	F	LIFTING PIN	SHOWN TO		
2	E	LIFTING PIN	SHOWN TO		
2	D	LIFTING PIN	SHOWN TO		
2	C	LIFTING PIN	SHOWN TO		
2	B	LIFTING PIN	SHOWN TO		
2	A	LIFTING PIN	SHOWN TO		
2	Z	LIFTING PIN	SHOWN TO		
2	Y	LIFTING PIN	SHOWN TO		
2	X	LIFTING PIN	SHOWN TO		
2	W	LIFTING PIN	SHOWN TO		
2	V	LIFTING PIN	SHOWN TO		
2	U	LIFTING PIN	SHOWN TO		
2	T	LIFTING PIN	SHOWN TO		
2	S	LIFTING PIN	SHOWN TO		
2	R	LIFTING PIN	SHOWN TO		
2	Q	LIFTING PIN	SHOWN TO		
2	P	LIFTING PIN	SHOWN TO		
2	O	LIFTING PIN	SHOWN TO		
2	N	LIFTING PIN	SHOWN TO		
2	M	LIFTING PIN	SHOWN TO		
2	L	LIFTING PIN	SHOWN TO		
2	K	LIFTING PIN	SHOWN TO		
2	J	LIFTING PIN	SHOWN TO		
2	I	LIFTING PIN	SHOWN TO		
2	H	LIFTING PIN	SHOWN TO		
2	G	LIFTING PIN	SHOWN TO		
2	F	LIFTING PIN	SHOWN TO		
2	E	LIFTING PIN	SHOWN TO		
2	D	LIFTING PIN	SHOWN TO		
2	C	LIFTING PIN	SHOWN TO		
2	B	LIFTING PIN	SHOWN TO		
2	A	LIFTING PIN	SHOWN TO		
2	Z	LIFTING PIN	SHOWN TO		
2	Y	LIFTING PIN	SHOWN TO		
2	X	LIFTING PIN	SHOWN TO		
2	W	LIFTING PIN	SHOWN TO		
2	V	LIFTING PIN	SHOWN TO		
2	U	LIFTING PIN	SHOWN TO		
2	T	LIFTING PIN	SHOWN TO		
2	S	LIFTING PIN	SHOWN TO		
2	R	LIFTING PIN	SHOWN TO		
2	Q	LIFTING PIN	SHOWN TO		
2	P	LIFTING PIN	SHOWN TO		
2	O	LIFTING PIN	SHOWN TO		
2	N	LIFTING PIN	SHOWN TO		
2	M	LIFTING PIN	SHOWN TO		
2	L	LIFTING PIN	SHOWN TO		
2	K	LIFTING PIN	SHOWN TO		
2	J	LIFTING PIN	SHOWN TO		
2	I	LIFTING PIN	SHOWN TO		
2	H	LIFTING PIN	SHOWN TO		
2	G	LIFTING PIN	SHOWN TO		
2	F	LIFTING PIN	SHOWN TO		
2	E	LIFTING PIN	SHOWN TO		

MKII D RESEATED SO

CLASS ---

AJ 104

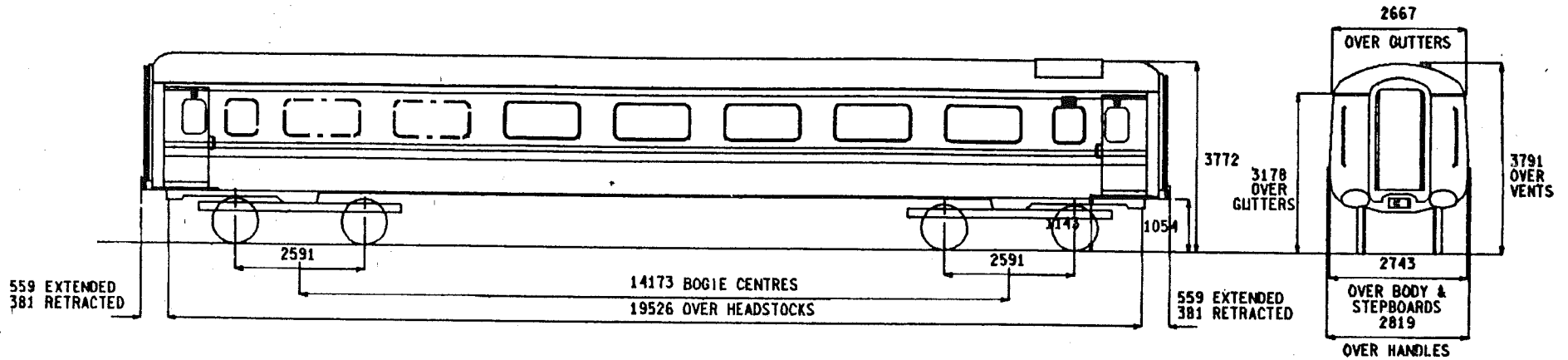

SEATING LAYOUT

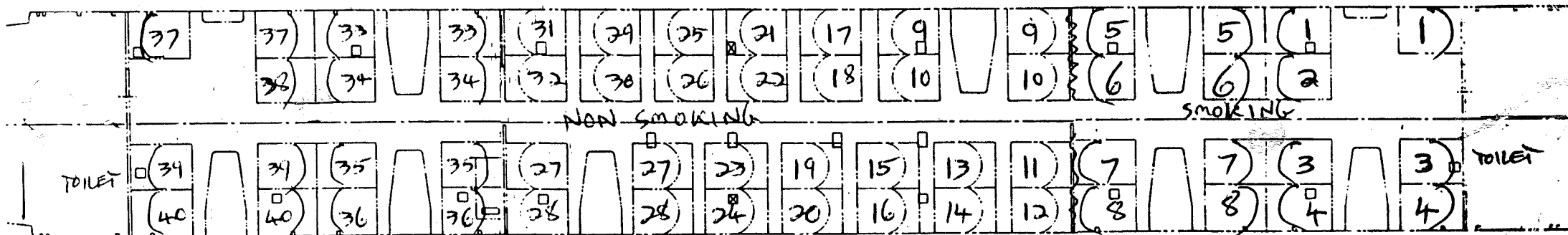

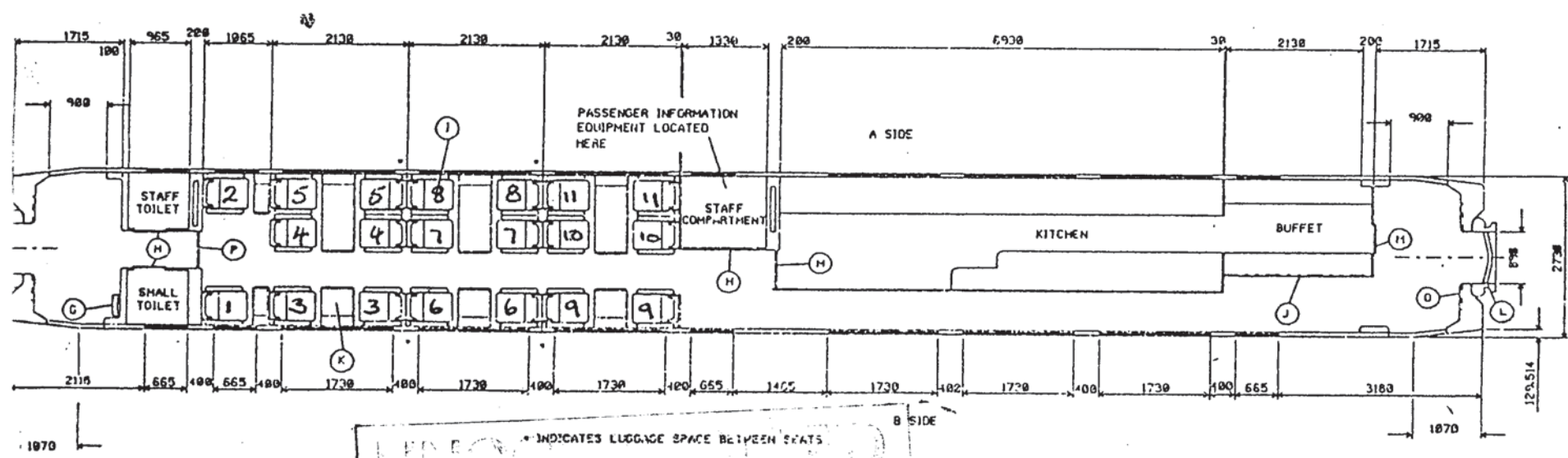
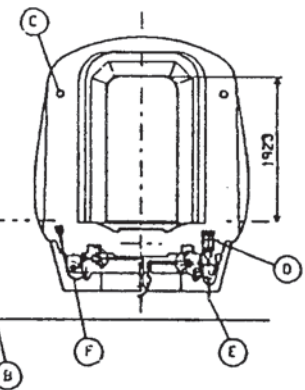
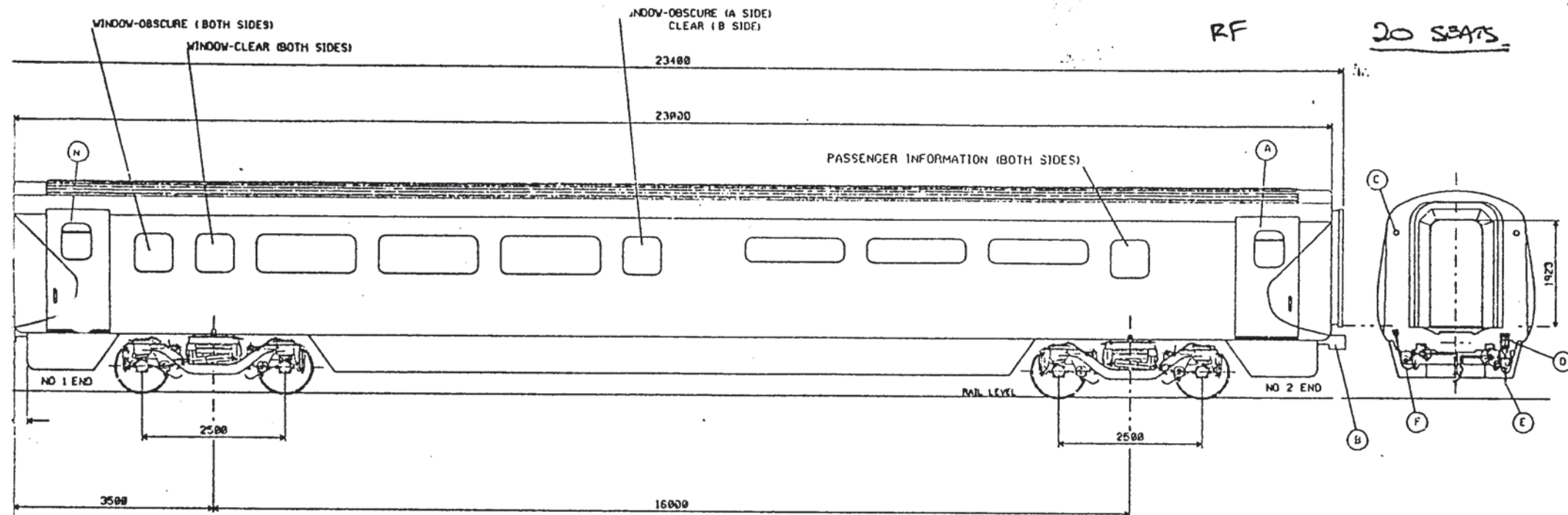

- KEY
- A) SLIDING PLUG DOOR
 - B) TIGHTLOCK COUPLER
 - C) TAIL LIGHT
 - D) BUFFER MOUNTING PAD
 - E) POWER JUMPER
 - F) FIDIC JUMPER
 - G) TIP-UP SEAT
 - H) HINGED DOOR
 - I) SEAT
 - J) ROLLER GRILL
 - K) TABLE
 - L) GANGWAY
 - M) SLIDING DOOR
 - N) MANUAL DOORS & LOADING RAMP BOTH SIDES
 - O) LOBBY DOOR
 - P) POWER SLIDING DOOR

C		F		G		H		I		J		K		L		M		N		O		P	
<p>THIS DRAWING IS THE PROPERTY OF BRB RESIDIARY LTD. IT IS TO BE USED ONLY FOR THE PURPOSES SPECIFIED IN THE DRAWING. IT IS NOT TO BE REPRODUCED, COPIED, OR TRANSMITTED IN ANY FORM OR BY ANY MEANS, WITHOUT THE WRITTEN PERMISSION OF BRB RESIDIARY LTD.</p>																							
<p>BRB RESIDIARY LTD 1125 SERVICE VEHICLE VA009B03</p>												<p>DATE: 95 DRAWN BY: RLV CHECKED BY: J.D.F.</p>											

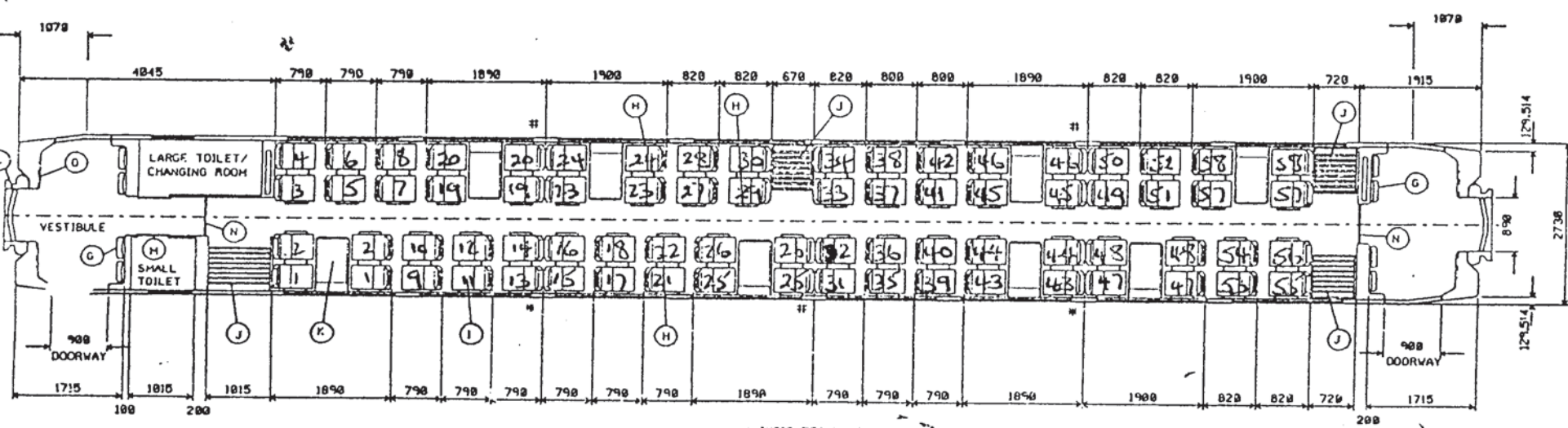
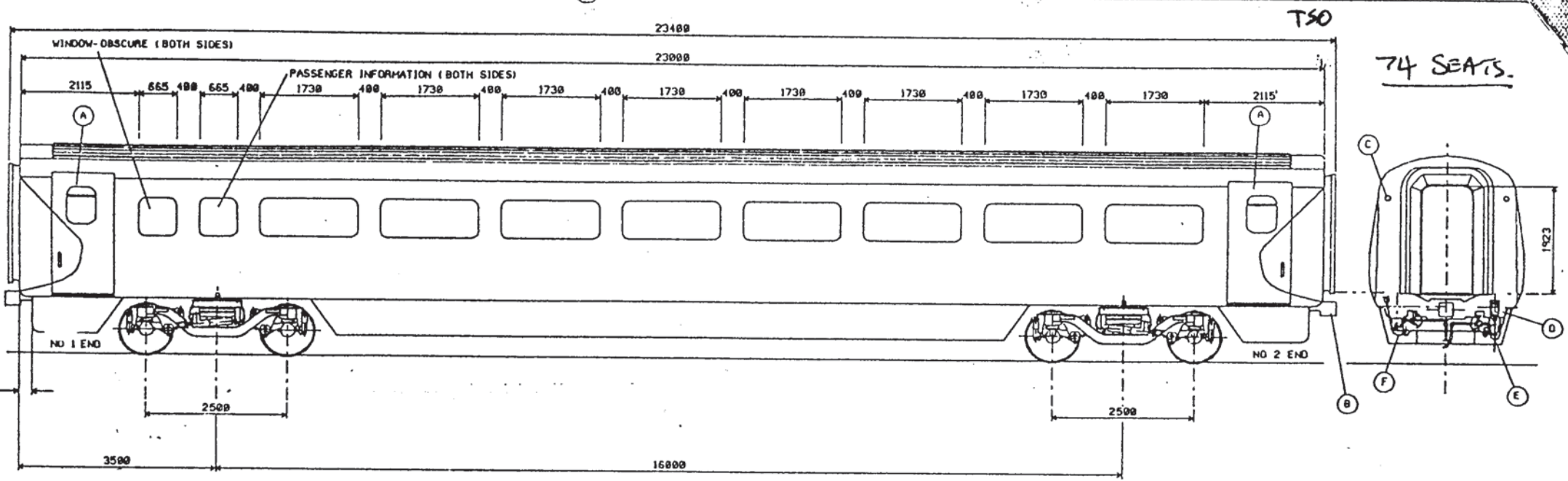

- KEY**
- A) SLIDING PLUG DOOR
 - B) TIGHTLOCK COUPLER
 - C) TAIL LIGHT
 - D) BUFFER MOUNTING PAD
 - E) POWER JUMPER
 - F) FJIC JUMPER
 - G) TIP-UP SEAT
 - H) MIARM REST
 - J) SEAT
 - K) LUGGAGE RACK
 - L) TABLE
 - M) GANGWAY
 - N) SLIDING DOOR
 - ⊕ POWER SLIDING DOOR
 - O) LOBBY DOOR

* INDICATES LUGGAGE SPACE BETWEEN SEATS
 # INDICATES PARTITION AND LITTER BIN
 ⊕ INDICATES SEAT BACK TABLES FITTED

NB. TOE AS TO

UNCONTROLLED DOCUMENT

METRO-CAMMELL LTD BRUSHMAN, ENGLAND		DATE	REV
DL	1120	REV	0/A TOURIST OPEN
DRW	VA004B03	REV	06

VEHICLE DIAGRAM BOOK

NO. 200

FOR LOCO HAULED COACHES

REVISION LETTER NO. 16

<u>LOCATION</u>	<u>ACTION</u>	<u>REASON FOR CHANGE</u>
Diagrams AB 103, 201, AC 201, 209, 213, AE 101, and AN 208	Replace with latest issue of these diagrams.)) Diagrams up-dated)
In alpha/numerical order	Insert new diagrams AJ 104 and AU 501	First issue

After incorporating the above, endorse the "Revision Record" at the front of the manual accordingly.

When this Revision Letter has been actioned, it is to be stored at the back of the publication (capacity permitting), for easy future reference.

DATE: JANUARY 1989

REF : 171-125-2

Issue by:-

D of M & EE, BRB
Railway Technical Centre
Derby

VEHICLE DIAGRAM BOOK

NO. 200

FOR LOCO-HAULED COACHES

REVISION LETTER NO. 15

<u>LOCATION</u>	<u>ACTION</u>	<u>REASON FOR CHANGE</u>
Index of Coaching Stock Numbers to Design Code, pages 1 to 24	Remove and destroy	Out of date For up-to-date information contact Rolling Stock Library, Trent House, RTC.
Diagrams AA 105, 303,) AB 102, 301, AC205,) 206, AD 103, 110,) AE 203, 204, AG 201,) AH 203 and 204)	Replace with .) latest issue of) these diagrams))	Diagrams up-dated
In alpha-numerical order	Insert new diagram AN 208.	First issue

After incorporating the above, endorse the "Revision Record" at the front of the manual accordingly.

When this Revision letter has been actioned, it is to be stored at the back of the publication (capacity permitting), for easy future reference.

Date : JUNE 1988

Ref : 220-12-2

Tel : 056-3582

Issued by:-

D of M & EE, BRB
Railway Technical Centre
Derby

VEHICLE DIAGRAM BOOK

NO. 200

FOR LOCO-HAULED COACHES

REVISION LETTER NO. 14

<u>LOCATION</u>	<u>ACTION</u>	<u>REASON FOR CHANGE</u>
Diagrams AA 302, AB 101, 106, 204, 302, AC 212, AD 103, 108, 206, AE 203, 206, 207, 208, AS 404 and AU 401	Replace with latest issue of these pages	Diagrams up-dated
In alpha/numerical order	Insert new diagrams AC 213, AJ 103, and AN 101	First issue
Diagram AJ 201	Remove and destroy this diagram	No longer required

After incorporating the above, endorse the "Revision Record" at the front of the manual accordingly.

When this Revision letter has been actioned, it is to be stored at the back of the publication (capacity permitting), for easy future reference.

Date : September 1987

Ref : 171-125-2

Tel : 056-3582

Issued by:-

D of M & EE, BRB
Railway Technical Centre
Derby

VEHICLE DIAGRAM BOOK
NO.200
FOR LOCO-HAULED COACHES
REVISION LETTER NO.13

<u>LOCATION</u>	<u>ACTION</u>	<u>REASON FOR CHANGE</u>
Diagrams AA 101, 201, 202, 301 to 304, AB 106, 202, AC 201, 204 to 211, AD 103, 106, 107, 108, 110, 201, AE 203, 205 to 208, AN 202, 203, AP 101 and AQ 101.))))))))))))))))))))
In alpha/numerical order	Insert new diagrams AA 207, 208, 209 and AD 206	First issue
Diagram AS 601	Remove and destroy this diagram.	No longer required

After incorporating the above, endorse the "Revision Record" at the front of the manual accordingly.

When this Revision letter has been actioned, it is to be stored at the back of the publication (capacity permitting) for easy future reference.

Date : February 1987

Ref : 171-125-2

Tel : 056 3582

Issued by:-

D of M & EE, BRB
Railway Technical Centre
Derby

VEHICLE DIAGRAM BOOK
NO 200
FOR LOCO-HAULED COACHES
REVISION LETTER NO 12

LOCATION	ACTION	REASON FOR CHANGE
Summary of Contents page, Issue 2	Replace with Issue 3 of this page	
Diagrams AA 201, AB 201, 204, AC 205, AE 203, 208 and AH 203	Replace with latest issue of these pages	Diagrams up-dated
In alpha/numerical order	Insert new Diagrams AD 301, AH 204 and AN 207	First Issue

After incorporating the above, endorse the "Revision Record" at the front of the manual accordingly.

When this Revision letter has been actioned, it is to be stored at the back of the publication (capacity permitting) for easy future reference.

DATE: JULY 1986

REF: 171-125-2

TEL: 056-3582

Issued by:-

D of M & EE, BRB
Railway Technical Centre
Derby

VEHICLE DIAGRAM BOOK

NO.200

FOR LOCO-HAULED COACHES

REVISION LETTER NO.10

<u>LOCATION</u>	<u>ACTION</u>	<u>REASON FOR CHANGE</u>
Diagrams AB 101, AF 201 and AJ 403	Replace with Issues 4 and 5 of these pages	Diagrams up-dated
In numerical order	Insert new Diagrams AA 303, 304, AD 110, AE 101, AJ 102 and 201	First issue
Diagram AJ 101	Remove and destroy this Diagram	No longer required

After incorporating the above, endorse the "Revision Record" at the front of the manual accordingly.

When this Revision letter has been actioned, it is to be stored at the back of the publication (capacity permitting) for easy future reference.

DATE: NOVEMBER 1985

REF: 171-125-2

TEL: 056-3582

Issued by:-

D of M & EE, BRB
Railway Technical Centre
Derby

VEHICLE DIAGRAM BOOK
NO. 200
FOR LOCO-HAULED COACHES
REVISION LETTER NO. 11

<u>LOCATION</u>	<u>ACTION</u>	<u>REASON FOR CHANGE</u>
Diagrams AA 202, 302, AB 101, 201, 202, 302, AC 201, AD 103, 104, AE 203, AJ 102, 403, AN 202, 203 and AS 301.	Replace with latest issue of these pages.	Diagrams up-dated.
In alpha/numerical order.	Insert new Diagrams AB 204 and AU 401.	First issue.
Diagrams AA 103, AJ 402, 407, 412 AN 205 and 206.	Remove and destroy these Diagrams.	No longer required.

After incorporating the above, endorse the "Revision Record" at the front of the manual accordingly.

When this Revision letter has been actioned, it is to be stored at the back of the publication (capacity permitting) for easy future reference.

DATE: MARCH 1986

REF: 171-125-2

TEL: 056-3582

Issued by :-

D of M & EE, BRB
Railway Technical Centre
Derby