

**NATIONAL RAILROAD
PASSENGER CORPORATION**



**NORTHEAST CORRIDOR
EMPLOYEE TIMETABLE No. 6**

(SPECIAL INSTRUCTIONS)

**Effective 12:01 A.M., Eastern Standard Time
Monday, February 22, 2016**

**Most Recent General Order:
No. 601, Effective Monday, February 22, 2016**



DJ STADTLER
Executive Vice President Operations

M. J. DECATALDO
General Manager
Northeast Corridor Business Line



AMTRAK'S VISION STATEMENT

Moving America where it wants to go.

OUR MISSION

**Delivering intercity transportation with superior
safety, customer service and financial excellence.**

TIMETABLE NO. 6 TABLE OF CONTENTS

SUBJECT	PAGE
Schedules Section	
Codes Used in Train Schedules	4
Index to Trains & Holiday Operations	See Current Bulletin Order
Train Schedules:	
Boston to New York	See Current Bulletin Order
New York to Boston	See Current Bulletin Order
Springfield to New Haven	See Current Bulletin Order
New Haven to Springfield	See Current Bulletin Order
New York to Hoffmans	See Current Bulletin Order
Hoffmans to New York	See Current Bulletin Order
New York to Washington	See Current Bulletin Order
Washington to New York	See Current Bulletin Order
Philadelphia to Harrisburg	See Current Bulletin Order
Harrisburg to Philadelphia	See Current Bulletin Order
<i>(Pages 5-100 intentionally omitted)</i>	
Special Instructions Section	
Special Instruction Numbering System	101
Letters and Symbols Used in Station Pages and Special Instructions	102
Line Special Instructions, including Station Pages:	
Main Line—New Haven to Boston	103
Dorchester Branch	125
Middleboro Main Line	131
Main Line—Mill River to Springfield	133
New Haven Line (Metro North Railroad)	141
Main Line—Harold to CP216	143
Main Line—New York to Hoffmans	147
Post Road Branch	155
Niagara Whirlpool Bridge	156
Hudson Line (Metro North Railroad)	157
New York Terminal District	159
Main Line—New York to Philadelphia	171
Main Line—Philadelphia to Washington	191
Washington Terminal District	215
Main Line—Philadelphia to Harrisburg	231
36 th Street Connection	243
Lehigh Line Connection	244
System Special Instructions	245
High Speed Trainset and HHP-8 Locomotive Special Instructions	342
Index to System Special Instructions	354
Appendix "A"—Emergency Procedures for New York Tunnels	A-1

LETTERS AND CHARACTERS

A ...	Final stop to discharge passengers.
S ...	Regular stop to receive or discharge passengers.
S* ...	Regular stop to receive or discharge passengers. May depart up to 3 minutes ahead of scheduled departure time.
R ...	Stops only to receive passengers.
R* ...	Regular stop to receive passengers. May depart up to 3 minutes ahead of scheduled departure time.
D ...	Stops to discharge passengers; may depart ahead of scheduled departure time.
L ...	Stops to receive or discharge passengers; may leave ahead of scheduled departure time.
F...	Flag stop to receive or discharge passengers, after advanced notice to conductor.
H ...	Regular stop; may depart up to 5 minutes ahead of scheduled departure time.
N...	Not a passenger stop; may depart when signal is displayed.
DHD...	Non-revenue train schedule.
LV ...	Gate time — May leave up to 1 minute ahead of scheduled departure time.
q ...	Gate time — May leave up to 2 minutes ahead of scheduled departure time.
RM ...	Reverse Move of train at the location.
+ ...	Operational note at location.
◇ ...	Schedule based on 110 mph equipment in train.
□ ...	Schedule based on High Speed Trainset.
☐ ...	Baggage service provided.

FREQUENCY CODES

D	Daily.
M-F	Monday through Friday.
Mon	Monday only.
M-Sa	Monday through Saturday.
M-Th	Monday through Thursday.
DexFr	Daily Except Friday
ThFr	Thursday and Friday only.
WeFr	Wednesday, Friday only.
WeFrSu	Wednesday, Friday and Sunday only.
Fri	Friday only.
Sat	Saturday only.
Sun	Sunday only.
Su-Fr	Sunday through Friday.
SaSu	Saturday and Sunday only.
Fri	Friday only.

Note: Due to frequent track work schedule changes, public timetables do not always agree with employee times. Also, published public times are different than employee times for S*, R*, H, LV, LX, D, and L stops.

SPECIAL INSTRUCTIONS

Numbering System

Special Instructions Numbered 34 through 47:

Special Instructions are generally numbered according to the Operating Rule number to which they refer. However, there is a gap between Rule 30 and Rule 70 in the Operating Rules. Certain of the missing numbers have therefore been assigned to the following operations:

Passenger Train Operation	34
Freight Train Operation	35
Passenger and Freight Train Operation	36
Speeds-Maximum and Various	37
Engine and Special Load Restrictions	40
Other Load and Equipment Restrictions	41
Wreck Derricks	42
Close Clearance	43
Hazardous Materials	45
Electrical Operation	47

Line Specific Special Instructions:

Special Instructions that refer to a specific line of railroad are listed following the applicable station page and are further identified by a letter(s) according to the line:

B	Main Line—New Haven to Boston
C	36 th Street Connection
D	Dorchester Branch
G	Main Line—Philadelphia to Harrisburg
H	Main Line—Harold to CP 216
L	Lehigh Line Connection
M	Main Line—Mill River to Springfield
N	Main Line—New York to Philadelphia
NG	Niagara Whirlpool Bridge
O	Middleboro Main Line
P	Main Line—Philadelphia to Washington
PR	Post Road Branch
T	New York Terminal District
U	Main Line—New York to Hoffmans
W	Washington Terminal

System Special Instructions:

Special Instructions that are not specific to a line of railroad are identified by the letter “S” to denote that they are System Special Instructions.

High Speed Trainset & HHP-8 Special Instructions:

Special Instructions which pertain only to the operation of High Speed Trainsets (HST) and HHP-8 locomotives are identified by the letter “A” to denote that they are HST & HHP-8 Special Instructions.

Appendix A:

Timetable Appendix “A” contains emergency procedures for the New York tunnels, and must be placed at the end of the Timetable.

(Continued on Next Page)

SPECIAL INSTRUCTIONS

Letters and Symbols Used in the Station Pages and Special Instructions

Br	Indicates a bridge
Cv or Cvs	Indicates curve or curves
DED	Dragging Equipment detector
HBD	Hot Box detector
IS	Interlocking Station
P	In service part time
PS	Passenger Station
R	Remotely controlled from
RA HB/DED	Radio Alarm Hot Box/Dragging Equipment Detector
RA WILD	Radio Alarm Wheel Impact Load Detector
WILD	Wheel Impact Load Detector
X	In service continuously

MAIN LINE—NEW HAVEN TO BOSTON (NHB)

STATIONS	MP	INT	PS	NOTES
NEW HAVEN	72.3	...	X	4
CP 273	R-MNR Section G RTC	72.4	X	...
CP 274	R-MNR Section G RTC	72.7	X	...
DIVISION POST (MNR)		72.9
MILL RIVER	R-Shore Line TD (Main Line-Mill River to Springfield) (CSX)(P & W RR)	73.6	X	...
SHORE LINE JCT	R-Shore Line TD	75.2	X	...
BRANFORD STATION		81.4	...	X 1
BRANFORD	R-Shore Line TD	81.5	X	...
PINE	R-Shore Line TD	82.8	X	...
ORCHARD	R-Shore Line TD	83.1	X	...
MEADOW	R-Shore Line TD	88.4	X	...
GUILFORD STATION		88.8	...	X ...
TRIEBEL	R-Shore Line TD	89.2	X	...
GUILFORD	R-Shore Line TD	90.4	X	...
MADISON		92.8	...	X 1
CLINTON		96.8	...	X 1
WESTBROOK		101.2	...	X ...
BROOK	R-Shore Line TD	103.6	X	...
SAYBROOK	R-Shore Line TD	104.7	X	...
OLD SAYBROOK		105.1	...	X ...
VIEW	R-Shore Line TD	105.9	X	...
CONN	R-See SI 900-B1 (Mvble. Brdg. Connecticut River)	106.8	X	...
CRESCENT	R-See SI 900-B1	115.0	X	...
NAN	R-See SI 900-B1 (Mvble. Brdg. Niantic River)	116.7	X	...
SHAWS COVE	R-See SI 900-B1 (Mvble. Brdg.) (NECR Connection)	122.5	X	...
NEW LONDON		122.9	...	X 3
GROTON	R-See SI 900-B1 (Mvble. Brdg. Thames River) (P&W R.R.)	124.2	X	...
PALMERS COVE	R-See SI 900-B1	128.1	X	...
MYSTIC RIVER	R-See SI 900-B1 (Mvble. Brdg.)	131.9	X	...
MYSTIC STATION		132.3	...	X ...
STATE LINE	(Conn.-R.I.)	141.1
WESTERLY		141.3	...	X ...
HIGH ST	R-See SI 900-B1	142.9	X	...
KINGSTON STATION		158.1	...	X ...
KINGSTON	R-See SI 900-B1	158.8	X	...
WICKFORD JUNCTION		165.9	...	X ...
STONY	R-See SI 900-B1	166.5	X	...
DAVISVILLE	R-See SI 900-B1 (Providence & Worcester R.R.)	168.0	X	...

MAIN LINE—NEW HAVEN TO BOSTON (NHB)

STATIONS		MP	INT	PS	NOTES
MALCOLM	R-Main Line TD	169.9	X	...	2, 10
PACKARD	R-Main Line TD	175.0	X	...	10
T.F. GREEN AIRPORT		176.8	...	X	...
POST	R-Main Line TD	178.5	X	...	8, 10
CRANSTON	R-Main Line TD (P & W RR)	181.2	X	...	10
ATWELLS	R-Main Line TD	184.2	X
BRAYTON	R-Main Line TD	184.9	X	...	9, 10
PROVIDENCE		185.1	...	X	...
ORMS	R-Main Line TD	185.6	X	...	10
PAWTUCKET	R-Main Line TD	187.1	X	...	2, 10
LAWN	R-Main Line TD (Providence & Worcester R.R.)	188.6	X	...	10
STATE LINE	(Mass.-RI)	190.8
SOUTH ATTLEBORO		191.9	...	X	...
HEBRONVILLE	R-Main Line TD	193.3	X	...	10
EAST JUNCTION		194.4
THATCHER	R-Main Line TD	196.2	X	...	8, 10
ATTLEBORO		196.9	...	X	...
BORO	R-Main Line TD (Middleboro Sec. Trk CSX)	197.2	X	...	7
HOLDEN	R-Main Line TD	198.1	X	...	10
MANSFIELD STATION		204.0	...	X	...
MANSFIELD	R-Main Line TD (Framingham Sec. Trk CSX)	204.0	X	...	10
SHARON		210.8	...	X	...
JUNCTION	R-Corridor TD (Stoughton Branch)	213.9	X	...	10
CANTON JUNCTION		213.9	...	X	...
ROUTE 128		217.3	...	X	...
TRANSFER	R-Corridor TD (Dorchester Branch)	218.5	X
READVILLE		219.2	...	X	...
READ	R-Corridor TD (Franklin Branch)	219.6	X
HYDE PARK		220.3	...	X	...
FOREST	R-Corridor TD (Needham Branch)	223.5	X
FOREST HILLS		223.7	...	X	...
PLAINS	R-Corridor TD (Needham Branch)	224.3	X
RUGGLES ST		226.5	...	X	...
BACK BAY		227.6	...	X	...
COVE	R-Terminal TD (Boston Line-CSX)	228.0	X	...	5
TOWER 1	R-Terminal TD (Dorchester Branch)	228.5	X	...	5, 11
BOSTON	(South Station)	228.7	...	X	

– Notes on Next Page –

MAIN LINE—NEW HAVEN TO BOSTON (NHB)

Mile Post distances are measured from New York, GCT (MNR).

The direction from New Haven to Boston is East.

Note 1: SI 121-B1 applies.

Note 2: Interlocking Rules apply on No. 2 and No. 4 tracks only.

Note 3: Rule 121(c) applies on No. 1 & 2 tracks only. Rule 121(b) applies on No. 6 track (NECR Connection).

Note 4: All movements in New Haven Yard, except in Parcel G, must use MN radio channel 056-056.

Note 5: Remotely controlled by Dorchester TD on weekends, beginning 11:00 PM Friday, until 11:00 PM Sunday.

Note 6: Int Rules apply on No. 1 trk & Controlled Siding only.

Note 7: Interlocking Rules apply on No. 4 track only.

Note 8: Interlocking Rules apply on No. 1 and No. 3 tracks only.

Note 9: Interlocking Rules apply on Nos. 1, 3, 5 & 7 tracks only.

Note 10: Equipped with movable point frogs. See SI 80-S1.

Note 11: Equipped with slip switches. See SI 80-S1.

240-B1. SIGNAL RULES and CURRENT OF TRAFFIC

251: On tracks where Rule 251 is in effect, the letter in parentheses () denotes the current of traffic: E=East, W=West, N=North, S=South. ABS Rules and CSS Rules 550 through 561 are in effect for movements with the current of traffic. Non-Signalled DCS Rules are in effect for movements against the current of traffic.

261: On trks where Rule 261 is in effect, ABS Rules & CSS Rules 550–561 are in effect for movements in both directions.

562: On tracks where Rule 562 is in effect, Rule 261, ABS Rules, and CSS Rules 550 through 563 (except Rules 554 and 556), are in effect for movements in both directions.

ACSES Rules: On tracks where the letter “A” follows the rule number, ACSES Rules 580–591 are in effect for movements in both directions.

Between	Tracks from South to North				Notes
	6	4	2	1	
CP 274 & Mill River	261	261	261	261	...
Between	Tracks from South to North				Notes
	4	2	1	3	
Mill River & Shore Line Jct	...	261-A	261-A
Shore Line Jct & Branford	...	562-A	562-A
Branford & Pine	...	562-A	261-A
Pine & Orchard	...	562-A	261-A
Pine Orchard Siding					3
Orchard & Meadow	...	562-A	562-A
Meadow & Triebel	261-A	261-A	562-A
Triebel & Guilford	...	261-A	562-A
Guilford & Brook	...	562-A	562-A
Brook & Saybrook	261-A	261-A	261-A	261-A	...
Saybrook & View	...	261-A	261-A	261-A	...
Gauntlet Track					5
View & Conn	...	261-A	261-A
Conn & Crescent	...	562-A	562-A
Crescent & Nan	...	261-A	261-A
Nan & Shaws Cove	...	562-A	562-A
Shaws Cove & Groton	...	261-A	261-A
Groton & Palmers Cove	261-A	261-A	562-A

240-B1. (Cont'd)					
Between	Tracks from South to North				Notes
	4	2	1	3	
Palmers Cove & Stony	...	562-A	562-A
Stony & Davisville	...	562-A	261-A	...	9
Davisville & Malcolm	...	261-A	562-A	...	6
Malcolm & Packard	...	562-A	562-A
Packard & Cranston	...	261-A	261-A	261-A	...
Cranston & Atwells	...	261-A	261-A	261-A	...
Atwells & Hebronville	...	261-A	261-A	...	4, 7, 8
Hebronville & Thatcher	261-A	261-A	261-A
Thatcher & Holden	261-A	261-A	261-A	261-A	...
Holden & Transfer	...	261-A	261-A
Transfer & Cove	...	261-A	261-A	261-A	...
Cove & Tower 1	Int. Rules in effect on Tracks Nos. 2, 1, 3, 5 & 7.				1, 2

Note 1: Int Rules in effect on Station trks 1–13 between Tower 1 & Boston. Station trks 1–13 are designated Main trks.

Note 2: CSS Rules 550 through 561 are in effect on Trks 2, 1, & 3, for all movements in both directions to and from Main Line-New Haven to Boston.

Note 3: Rule 261, ABS, CSS Rules 550–561, and ACSES Rules 580–591 in effect on Pine Orchard Siding.

Note 4: Providence - Station Trks. 3 & 5 between Orms & Brayton designated Main Track, Rule 261-A in effect.

Note 5: Rule 261 in effect, CSS Rules are not in effect.

Note 6: No. 4 track within Malcolm Interlocking extends west 7,493 feet to “Begin/End Signal Territory” sign.

Note 7: West of Pawtucket Int, Trk 4 designated Turnkey Industrial Trk; East of int, designated as yard trk.

Note 8: No. 7 trk designated Main Track between Atwells and Orms. Rule 261-A in effect.

Note 9: 3 trk within Stony Int extends west 2521 feet to “Begin/End Signal Territory” sign.

37-B1. PASSENGER TRAINS and FREIGHT TRAINS MAXIMUM SPEEDS and SPEED RESTRICTIONS, UNLESS OTHERWISE RESTRICTED

Locations and speeds shown in normal type are maximum authorized speeds. Locations and speeds shown in **bold type** are speed restrictions. *Maximum equipment speeds listed in SI 37-S5 (pgs. 289-304) must not be exceeded.*

Where speeds change at an interlocking and the specific point where the speed change occurs is not specified, the lower speed will apply through the entire interlocking.

PASSENGER TRAIN TYPE “A”, “B”, “C” & “D” SPEEDS

Train Type A refers to High Speed Trainsets (HST) with tilt system **active**.

Train Type B refers to (1) HST’s with tilt system **disabled**; and (2) trains consisting **exclusively** of HHP-8, AEM-7, ACS-64, P40BH, P42BH, P32AC-DM, or P32-BWH engines, and Amfleet, Horizon, and Capitoline Control cars, LDSL Baggage Cars 61000-61084, or US DOT Test Car DOTX 216.

Train Type C refers to passenger trains that do not meet the criteria for types A, B, or D.

Train Type D refers to passenger trains with mail, baggage or express cars in consist, that meet the Train Type D criteria defined in SI 37-S8, page 304.

37-B1. (Cont'd)

NOTE: Trains must not exceed 110 MPH between New Haven and Boston unless ACSES is in service on the affected track. (See SI 580-B1, page 124)

NOTE: Train Type "D" trains must not exceed 60 MPH when operating with inoperative cab signals.

PASSENGER TRAIN TYPE "A", "B", "C" & "D" SPEEDS

Between/At	Train Type "A"			Train Type "B"			Train Type "C"			Train Type "D"		
	Track Nos.			Track Nos.			Track Nos.			Track Nos.		
	2	1	Other	2	1	Other	2	1	Other	2	1	Other
Division Post & Mill River	50	50	...	50	50	...	35	35	...	35	35	...
Nos. 4 & 6 Trks.	35	35	35	35
Mill River & MP 76	70	70	...	70	70	...	70	70	...	70	70	...
Cv MP 74.1 & MP 74.2	55	55	...	55	55	...
Cv MP 74.2 & MP 76.0	65	65	...	60	60	...	60	60	...
Shore Line Jct Int limits	60	60	...	60	60	...	60	60	...	60	60	...
MP 76 & MP 81.7	80	80	...	70	70	...	70	70	...	70	70	...
Cv MP 77.9 & MP 78.1	75	75	...	65	65	...	60	60	...	60	60	...
Cv MP 80.0 & MP 80.2	75	75	60	60	...	60	60	...
Cvs MP 81.1 & MP 81.7	60	60	...	55	55	...	50	50	...	50	50	...
MP 81.7 & MP 85.6	120	120	...	110	110	...	90	90	...	90	90	...
Cv MP 81.7 & MP 82.4	110	110	...	100	100
Cv MP 83.2 & MP 83.7	110	110	...	100	100
Pine & Orchard: Pine Orchard Siding	30	30	30	30
MP 85.6 & MP 87.5	95	95	...	95	95	...	90	90	...	90	90	...
Cv MP 85.6 & MP 86.0	85	85	...	80	80	...	70	70	...	70	70	...
Cv MP 87.2 & MP 87.5	85	85	...	75	75	...	65	65	...	65	65	...
MP 87.5 & MP 88.3	115	115	...	100	100	...	90	90	...	90	90	...
MP 88.3 & MP 94	125	125	...	115	115
Meadow & Triebel: No. 4 Track	45	45	45	45
Cv MP 93.0 & MP 93.3	100	100	...	90	90	...	80	80	...	80	80	...
MP 94 & MP 99.7	120	120	...	95	95	...	90	90	...	90	90	...
Cv MP 94.4 & MP 94.8	85	85	...	80	80	...	70	70	...	70	70	...
Cv MP 96.2 & MP 96.6	105	105	85	85	...	85	85	...
MP 99.7 & MP 103.9	90	90	...	90	90	...	90	90	...	90	90	...
Cv MP 99.7 & MP 100.1	80	80	...	70	70	...	70	70	...
Cv MP 100.1 & MP 101.0	85	85	...	80	80	...	80	80	...
Cv MP 102.0 & MP 102.2	80	80	...	70	70	...	65	65	...	65	65	...
Cv MP 103.7 & MP 103.9	85	85	...	75	75	...	75	75	...
MP 103.9 & View	110	110	...	90	90	...	90	90	...	90	90	...
Brook & Saybrook: No. 3 Track	30	30	30	30
No. 4 Track	15	15	15	15
Saybrook & View: No. 3 Trk	30	30	30	30
Saybrook & MP 104.9: No. 3 Trk	15	15	15	15
View & Conn	110	110	...	80	80	...	80	80	...	80	80	...

37-B1. (Cont'd)

PASSENGER TRAIN TYPE "A", "B", "C" & "D" SPEEDS

Between/At	Train Type "A"			Train Type "B"			Train Type "C"			Train Type "D"		
	Track Nos.			Track Nos.			Track Nos.			Track Nos.		
	2	1	Other	2	1	Other	2	1	Other	2	1	Other
Conn & MP 109.6	110	110	...	80	80	...	75	75	...	75	75	...
Cv MP 106.3 & MP 106.6	70	70	...	55	55	...	45	45	...	45	45	...
Conn Int (Moveable Span Only) . . .	45	45	...	45	45	...	45	45	...	45	45	...
Conn Int limits	60	60	...	60	60	...	60	60	...	60	60	...
Cv MP 107.0 & MP 107.4	90	90	70	70	...	70	70	...
MP 109.6 & Nan	90	90	...	80	80	...	75	75	...	75	75	...
Cvs MP 112.1 & MP 112.8	70	70	...	65	65	...	60	60	...	60	60	...
Nan & MP 123	75	75	...	65	65	...	65	65	...	65	65	...
Nan Int limits	70	70	...	65	65	...	65	65	...	65	65	...
Cv MP 118.8 & MP 119.3	75	75	60	60	...	60	60	...
Cv MP 120.8 & MP 121.6	60	60	...	55	55	...	50	50	...	50	50	...
Shaw's Cove Int limits	60	60	...	60	60	...	60	60	...	60	60	...
Cvs MP 122.4 & MP 123	25	25	...	25	25	...	20	20	...	20	20	...
MP 123 & MP 124	40	40	...	40	40	...	35	35	...	35	35	...
MP 124 & MP 126.5	65	65	...	60	60	...	60	60	...	60	60	...
Groton & MP 127.0: No. 4 Trk	10	10	10	10
Cv MP 124.0 & MP 124.3	50	50	...	50	50	...	40	40	...	40	40	...
Cv MP 125.3 & MP 125.7	60	60	...	55	55	...	50	50	...	50	50	...
Cv MP 126.3 & MP 126.5	55	55	...	55	55	...
MP 126.5 & MP 132	90	90	...	80	80	...	70	70	...	70	70	...
MP 127 & Palmers Cove: No. 4 Trk	10	10	10	10
Cv MP 129.3 & MP 129.8	70	70	...	65	65	...	55	55	...	55	55	...
Cv MP 129.8 & MP 130.1	75	75	...	70	70	...	65	65	...	65	65	...
Cv MP 131.2 & MP 131.9	80	80	...	75	75	...	65	65	...	65	65	...
Br MP 131.9 & MP 132.0	60	60	...	60	60	...	60	60	...	60	60	...
MP 132 & MP 136.4	75	75	...	70	70	...	70	70	...	70	70	...
Cv MP 132.0 & MP 132.5	60	60	...	60	60	...	50	50	...	50	50	...
Cv MP 133.6 & MP 134.0	70	70	...	65	65	...	55	55	...	55	55	...
Cv MP 134.9 & MP 135.4	65	65	...	60	60	...	60	60	...
Cv MP 135.4 & MP 135.7	65	65	...	60	60	...	60	60	...
Cv MP 135.9 & MP 136.4	65	65	...	60	60	...	50	50	...	50	50	...
MP 136.4 & MP 142.1	90	90	...	80	80	...	80	80	...	80	80	...
Crossings: MP 136.4 & MP 136.7	80	80
Cvs MP 138.5 & MP 141.5	75	75	...	75	75	...
Palmer St. X'ing (MP 140.6)	75	75	...	75	75	...
Cv MP 141.8 & MP 142.1	85	85	70	70	...	70	70	...
MP 142.1 & MP 145.5	90	90	...	90	90	...	90	90	...	90	90	...
Cv MP 142.4 & MP 142.7	80	80	...	80	80	...	80	80	...

37-B1. (Cont'd)

PASSENGER TRAIN TYPE "A", "B", "C" & "D" SPEEDS

Between/At	Train Type "A"			Train Type "B"			Train Type "C"			Train Type "D"		
	Track Nos.			Track Nos.			Track Nos.			Track Nos.		
	2	1	Other	2	1	Other	2	1	Other	2	1	Other
Cv MP 144.1 & MP 144.6	80	80	...	75	75	...	75	75	...
Cv MP 145.1 & MP 145.5	85	85	...	75	75	...	70	70	...	70	70	...
MP 145.5 & MP 154.3	105	105	...	90	90	...	90	90	...	90	90	...
Cv MP 147.3 & MP 148.1	95	95	...	85	85	...	75	75	...	75	75	...
Cv MP 150.8 & MP 151.0	95	95	80	80	...	80	80	...
Cv MP 151.9 & MP 152.5	85	85	...	80	80	...	70	70	...	70	70	...
Cv MP 154.0 & MP 154.3	90	90	...	85	85	...	75	75	...	75	75	...
MP 154.3 & MP 171.7	150	150	...	150	150	...	110	110	...	90	90	...
Cv MP 159.7 & MP 160.5	130	130	...	120	120	...	100	100
Stony Int: No. 3 Trk	45	45	45	45
Malcolm Int: No. 4 Trk	45	45	45	45
Cv MP 170.5 & MP 170.9	130	130	...	125	125	105
MP 171.7 & MP 174.5	115	115	...	115	115	...	110	110	...	90	90	...
Cv MP 171.7 & MP 172.3	110	110	...	95	95	...	85	85	...	85	85	...
Cv MP 173.0 & MP 173.4	105	105	...	90	90
Cv MP 174.0 & MP 174.5	105	105	...	100	100	...	85	85	...	85	85	...
MP 174.5 & MP 180.5	150	150	...	125	125	...	110	110	...	90	90	...
Packard & MP 181.7: No. 3 Trk	50	50	50	40
No. 3 Trk:												
Cvs MP 176.3 & MP 176.6	45	45	45
Cvs MP 176.6 & MP 176.7	25	25	25	25
Cv MP 177.6	45	45	45
Cvs MP 178.7 & MP 179.1	40	40	40
Cvs MP 180.1 & MP 180.4	45	45	45
Cv MP 180.1 & MP 180.2	120	120	...	105	105	...	90	90
Cv MP 180.2 & MP 180.5	110	110	...	100	100	...	90	90
MP 180.5 & MP 181.7	100	100	...	90	90	...	80	80	...	80	80	...
No. 3 Trk:												
MP 181.7 & MP 183.1	45	45	45	40
MP 183.1 & MP 183.6	30	30	30	30
MP 183.6 & East Limits Atwells	25	25	25	25
MP 181.7 & Providence	70	70	...	60	60	...	60	60	...	60	60	...
Atwells & Orms:												
No. 7 Trk	20	20	20	20
Cv MP 181.7 & MP 181.9	55	55	...	50	50	...	45	45	...	45	45	...
Cv MP 182.3 & MP 182.8	65	65	50	50	...	50	50	...
Cvs MP 184.3 & MP 184.8	60	60	...	55	55	...	45	45	...	45	45	...
Cv West of Providence	30	30	...	30	30	...	30	30	...	30	30	...
Providence & MP 190.5	70	70	...	70	70	...	70	70	...	70	70	...
Station Tracks 3 & 5	25	25	25	25
Providence Sta. Platforms	30	30	...	30	30	...	20	20	...	20	20	...
Cv East of Providence	30	30	...	25	25	...	20	20	...	20	20	...
Cvs MP 185.4 & MP 186.4	60	60	...	55	55	...	50	50	...	50	50	...

37-B1. (Cont'd)

PASSENGER TRAIN TYPE "A", "B", "C" & "D" SPEEDS

Between/At	Train Type "A"			Train Type "B"			Train Type "C"			Train Type "D"		
	Track Nos.			Track Nos.			Track Nos.			Track Nos.		
	2	1	Other	2	1	Other	2	1	Other	2	1	Other
Cv MP 188.7 & MP 189.2	60	60	...	55	55	...	50	50	...	50	50	...
Cvs MP 189.5 & MP 190.5	60	60	...	55	55	...	50	50	...	50	50	...
MP 190.5 & MP 194.5	125	125	...	125	125	...	110	110	...	90	90	...
Hebronville & Thatcher: No. 4 Track	60	60	60	60
Cv Hebronville & MP 194.5 No. 4 Track	110	110	...	100	100	...	90	90
	30	30	30	30
Thatcher & Holden: No. 3 Track	80	80	80	80
No. 4 Track	60	60	60	60
MP 194.5 & MP 205	150	150	...	150	150	...	110	110	...	90	90	...
MP 205 & Transfer	130	130	...	120	120	...	100	100	...	90	90	...
Cv MP 206.6 & MP 207.0	125	125	...	115	115
Cv MP 213.0 & MP 213.8	125	125	115
Transfer & MP 226	120	120	...	110	110	...	100	100	...	90	90	...
Transfer & Read: No. 3 Track	60	60	60	60
Read & Forest: No. 3 Track	80	80	80	80
Forest & MP 226: No. 3 Track	100	100	100	100
Cv MP 220.4 & MP 220.7	105	105	...	95	95
Cv MP 222.1 & MP 222.3	115	105	90	95
MP 226 & MP 227 No. 3 Track	120	120	...	110	110	...	100	100	...	90	90	...
	100	100	100	90
MP 227 & West Limits Cove Int No. 3 Track	60	60	...	60	60	...	60	60	...	60	60	...
	60	60	60	60
Cv MP 227.3 & MP 228 No. 3 Track	30	30	...	30	30	...	25	25	...	25	25	...
	30	30	25	25
Within Limits Cove No. 3 Track	30	30	...	30	30	...	25	25	...	25	25	...
	30	30	25	25
Tracks 5 & 7	30	30	30	30
Cove: Diverting between No. 1 & No. 2 Tracks	15	15	15	15
East Limits Cove & Tower 1:	All Tracks — 15 MPH						All Tracks — 15 MPH					
Tower 1 & Boston:	All Tracks — 10 MPH						All Tracks — 10 MPH					

37-B1. (Cont'd)

FREIGHT TRAIN TYPE "E" SPEEDS

NOTE: Freight trains with inoperative cab signals must operate in accordance with S.I. 555-B1, page 124.

Between/At	Train Type "E"		
	Track Nos.		
	No. 2	No. 1	Other
Division Post & Mill River	20	20	...
Nos. 4 & 6 Trks.	20
Mill River & Shore Line Jct	20	20	...
Shore Line Jct, Diverting movements	10
Shore Line Jct & MP 77	30	30	...
MP 77 & Pine	40	35	...
Pine & Orchard	50	20	...
Pine & Orchard: Pine Orchard Siding			20
Orchard & Brook	50	50	...
Meadow & Triebel: No. 4 Trk	20
Brook & Saybrook	50	50	...
Nos. 3 & 4 Trks.	10
Within Limits of Saybrook Int	45	45	...
Saybrook & View	45	45	...
No. 3 Trk	10
View & Conn	25	25	...
Conn & Nan	50	50	...
Within Limits Nan Int	45	45	...
Nan & Shaws Cove	45	45	..
Cv MP 120.8 & MP 122.0	40	40	...
Shaws Cove & Groton	25	25	...
Cv MP 122.7 & MP 123.0	15	15	...
Groton & Palmers Cove	40	40	...
No. 4 Trk.	10
Cv at Groton Int	35
Palmers Cove & Mystic	35	35	...
Within Limits Mystic Int	40	40	...
Mystic & High St	50	50	...
Cv MP 132.0 & MP 132.5	40	40	...
High St & Kingston	50	50	...
Cv MP 151.9 & MP 152.5	45	45	...
Kingston & Cranston	50	50	...
Stony Int: No. 3 Trk	Restricted Speed		
Malcolm Int: No. 4 Trk	30 MPH		
Packard & MP 181.7: No. 3 Trk	40
Cvs MP 176.6 & MP 176.7: No. 3 Trk	25
MP 181.7 & MP 183.1: No. 3 Trk	40
MP 183.1 & MP 183.6: No. 3 Trk	30
MP 183.6 & East limits Atwells: No. 3 Trk	25
Cranston & East limits Atwells	30	30	...
East limits Atwells to Brayton	15	15	...
Brayton to Orms	15	10	...
Atwells & Orms: No. 7 Trk	20

37-B1. (Cont'd)			
FREIGHT TRAIN TYPE "E" SPEEDS			
Between/At	Train Type "E"		
	Track Nos.		
	No. 2	No. 1	Other
Orms to MP 190.5	30	30	...
MP 190.5 & Hebronville	50	50	...
Hebronville & Thatcher	50	50	...
No. 4 Trk.	40
Cv Hebronville & MP 194.5: No. 4 Trk.	30
Thatcher & Holden	50	50	...
No. 3 Trk.	50
No. 4 Trk.	40
Holden & Transfer	50	50	...
Canton Jct Station Platform	40	40	...
Transfer & Read	20	20	...
No. 3 Trk.	20
Read & Forest	50	50	...
No. 3 Trk.	45
Forest & Plains	20	20	...
No. 3 trk	20
Plains & MP 227	45	45	...
No. 3 trk	45
MP 227 & West Limits Cove	30	30	...
No. 3 trk.	30
Cv MP 227.3 & MP 228	15	15	...
No. 3 trk	10
Within Limits Cove Int	25	25	...
Tracks 3, 5 & 7	25
Cove: Diverting between No. 1 & No. 2 trks.	10
East Limits Cove & Boston	All Tracks – 10 MPH		

C-B1. OPERATING RULES QUALIFICATION

Amtrak Train & Engine service employees who operate over Metro-North territory solely within the New Haven Terminal area, including CP 274, CP 273, CP 272 & CP 271, are not required to attend a Metro-North Operating Rules Class. Instruction on the Metro-North Operating Rules required for operating in these areas, where they differ from those of Amtrak, will be included in Amtrak Operating Rules classes. This does not relieve such employees from meeting Metro-North's requirements for qualifying on the physical characteristics of the territory involved.

Metro-North Train and Engine service employees who operate over Amtrak between Division Post, MP 72.9 and MP 73.0 are not required to attend a NORAC operating rules class. Instruction on NORAC rules where they differ from those of Metro-North will be given as part of Metro-North rules class. This does not relieve Metro-North's employees from meeting Amtrak's requirements for qualifying on the physical characteristics of the territory involved.

F-B1. TUNNEL/WALL EMERGENCY EXITS

Emergency exits are in service at the following locations on the No. 2 Track side of the Main Line—New Haven to Boston, between Forest Hills and Back Bay: MP 223.87, 224.04, 224.23, 224.45, 224.61, 224.76, 224.96, 224.96, 225.11, 225.30, 225.54, 225.77, 225.93, 226.04, 226.20, 226.96, 227.15 and 227.31.

F-B2. EMERGENCY TELEPHONES

ATS Telephones are in service at the locations listed below. These telephones are in grey boxes marked with the letter "T" in reflectorized tape. Where practical, telephones are located at the signal bungalow at designated location:

Location	Mile Post	Telephone No.
Cut Section West of Back Bay	227.6	580-7594
West Newton St. Stairwell	227.2	580-7910
Cut Section Wellington St.	227.1	580-7583
Ruggles St.	226.5	580-7584
Plains	224.3	580-7588
Forest	223.5	580-7589

1-B1. SHORE LINE EAST CUSTOMER SERVICES NOTICES

Shore Line East (SLE) Customer Services employees must read and comply with all SLE Customer Services Notices that are addressed to them. They are not required to carry these notices while on duty, but must be conversant with the contents of all notices in effect. SLE Customer Services Notices will be:

- ▶ Issued as required by the District Superintendent or staff of Shore Line East Commuter Rail.
- ▶ Numbered sequentially, the number being prefixed by the last two digits of the current year.
- ▶ Distributed and posted at signup locations and Train Dispatchers' office.

1-B2. BOSTON TERMINAL OPERATIONS NOTICE

Boston Terminal Operations Notices (BTON) will be issued as required, and will be numbered sequentially, the number being suffixed by the last two digits of the calendar year. The number of the most recent BTON will be published at the top of the Bulletin Order.

All yard employees working in Southampton Street Yard and Protect Crews reporting at South Station must read and retain a copy of the BTON. Road Crews must read these instructions, but are not required to carry them while on duty.

1-B3. METRO-NORTH RAILROAD GENERAL ORDERS AND BULLETIN ORDERS

In addition to a copy of the current Metro-North Railroad Operating Rules/Timetable, Amtrak employees operating within the New Haven Terminal area must carry all General Orders and Bulletin Orders while on duty.

16-B1. BLUE SIGNAL PROTECTION: BOSTON SOUTH STATION TRACK 1 THROUGH 13

The following blue signal protection procedures apply on Boston South Station tracks 1-13, which are designated as Main Tracks in SI 240-B1.

Responsibility of All Mechanical Employees

Mechanical employees must not perform any work that requires blue signal protection until assured by the Mechanical Foreman or qualified craft employee in charge that blue signal protection has been provided.

Responsibilities of Mechanical Foreman or Qualified Craft Employee

Before authorizing or performing any work that requires blue signal protection, the requirements regarding Blue Signal Protection on Main Tracks must be complied with. If supplemental protection is desired, the Mechanical Foreman or qualified craft employee in charge may obtain additional protection by taking the following actions:

1. Contact the Terminal Train Dispatcher on radio channel 054-054 to obtain "Supplemental Blue Signal Protection" on the required track.

NOTE: The protection is considered "supplemental" because the law that governs blue signal protection on Main Tracks requires only actions 2 and 3 below.

2. Display a Blue Signal at each end of the equipment to be worked.
3. Attach a Blue Signal to the controlling engine(s) at a location where it will be clearly visible to an employee at the controls of that engine.

16-B1. (Cont'd)

After all work has been completed, the individual who requested the "Supplemental Blue Signal Protection" will check to see that all employees are in the clear, then call the Dispatcher to give up the protection.

Responsibilities of Terminal Train Dispatcher

The Terminal Train Dispatcher must take the following actions when granting "Supplemental Blue Signal Protection":

1. Before granting "Supplemental Blue Signal Protection," the Dispatcher must apply blocking devices to prevent the display of any signal leading to the affected track.
2. Once "Supplemental Blue Signal Protection" is granted, the Dispatcher must not remove the blocking devices or authorize any equipment to enter the track until informed by the employee in charge of the workmen that the work has been completed.
3. The Dispatcher must immediately make a written record on the prescribed form of the application and removal of the blocking device protection. This record must be retained for 15 days following the date of removal.

19-B1. ENGINE WHISTLE OR HORN SIGNALS - BOSTON SOUTH STATION

All trains must sound engine whistle signal two short sounds prior to moving from platform.

20-B1. ENGINE BELL

The engine bell must be sounded continuously when operating within Tower 1 limits.

34-B1. TRAIN APPROACH MESSAGE SYSTEM (TAMS)

Train Approach Message System (TAMS) is in service at the following stations: Branford, Guilford, Madison, Clinton, Westbrook, Mystic, Westerly, Kingston, South Attleboro, Mansfield, Sharon, Canton Jct., Route 128, Readville, Hyde Park, Forest Hills and Ruggles.

If TAMS is not functioning properly at any of these stations, the Dispatcher must:

1. Issue a 110 MPH speed restriction on the affected track(s), with limits designated to protect the affected station(s).
2. Issue verbal or Form D line 13 instructions requiring trains not scheduled to stop at the affected station(s) to blow one long sound of the engine horn when approaching each affected station on a track adjacent to a station platform.

Exception: The 110 MPH speed restriction and horn requirement will not be necessary when on-ground personnel are provided to protect the station(s) where a TAMS failure has occurred. These persons must monitor train movements through the GETC office and radio communication with trains. They must notify passengers to remain behind the yellow line when a train is approaching. Only the following categories of personnel may be relied upon to provide on-ground protection:

1. A train crew member.
2. A uniformed law enforcement officer (railroad or police).
3. A uniformed Customer Services employee.
4. An employee who is equipped by day with an orange vest, shirt or jacket; and by night with a retroreflective orange, white or yellow vest, shirt or jacket.

35-B1. PROVIDENCE STATION: FREIGHT TRAINS

Freight trains containing cars which exceed Plate C dimensions are prohibited from operating on Nos. 1, 2, 3 and 5 tracks.

36-B1. PROVIDENCE STATION: STOP LOCATIONS

Eastward trains stopping at Providence Station must stop locomotive(s) outside of the station tunnel. Westward trains stopping at Providence Station must stop locomotive(s) under exhaust vent openings at the west end of the station platforms.

36-B2. PROVIDENCE YARD: ENGINE STORAGE

Train crews must store engines on the west end of Track 11 in the Engine Storage Area at the completion of work.

36-B3. BACK BAY TUNNEL

Engines and control cars must not exceed the sixth throttle position while operating through the Back Bay Tunnel.

36-B4. BACK BAY – LOCATIONS FOR TRAINS STOPPING

Diesel Engines	Must not be stopped under Bridge 228.41, Harrison Ave.
Eastward Trains	Must stop locomotive(s) east of the low station ceiling.
Westward Trains	Must spot train with locomotive(s) entirely west of the escalator.

36-B5. SOUTH STATION: DIESEL OPERATION

All trains arriving South Station must not be stopped with diesel locomotive(s) under overhead bus terminal, unless otherwise instructed by the Terminal Train Dispatcher. For reference, car markers have been installed on all platforms.

Trains arriving South Station on Tracks 8, 9, and 10 may pull down to the end of track. Vent fans for Tracks 8, 9, and 10 are installed and in service.

NOTE: This instruction does not apply to double drafts. When necessary for double draft to be brought into the station it must not remain longer than necessary.

36-B6. PROVIDENCE STATION TUNNEL: DIESEL OPERATION

Engines and control cars must not exceed the fifth throttle position while operating through the Providence Station Tunnel.

37-B2. SPEEDOMETER CHECKING: MEASURED MILES

The distance between the sets of Mile Posts listed below is a measured mile. White marker posts are installed on both sides of the tracks at locations marked with an asterisk(★).

*MP 78- *MP 79	MP 150- MP 151	MP 199- *MP 200
*MP 83- *MP 84	MP 154- MP 155	*MP 200- *MP 201
MP 93- MP 94	MP 161- MP 162	MP 214- MP 215
MP 96- MP 97	MP 163- MP 164	MP 215- MP 216
MP 107- MP 108	*MP 164- *MP 165	MP 217- MP 218
MP 113- MP 114	MP 166- MP 167	MP 219- MP 220
MP 115- MP 116	MP 169- MP 170	MP 220- MP 221
MP 119- MP 120	MP 174- MP 175	MP 221- MP 222
MP 131- MP 132	MP 175- MP 176	
MP 149- MP 150	*MP 192- *MP 193	

37-B3. MAXIMUM SPEEDS-OTHER TRACKS

Location/Between	Tracks	Restricted Speed not exceeding
Parcel G	All	5 MPH
New Haven - CDOT Shop	All	5 MPH
Mill River and Boston	All industrial tracks and yard tracks	10 MPH
Clinton	Clinton Siding	15 MPH Psgr. 10 MPH Frt.
Saybrook & View	Gauntlet Track	10 MPH
Groton Interlocking	Wye Tracks	10 MPH
Begin/End Signaled Territory sign at Stony and End of Track	No. 3	10 MPH
Pawtucket (MP 187)	Turnkey Industrial	5 MPH
Cove & Broad	Wye Connector	10 MPH

40-B1. ENGINE AND EQUIPMENT RESTRICTIONS

The numbers shown in the columns to the right of each listed location specify the maximum height of the engines and equipment that may be operated. Engine and equipment dimension specifications are assigned in S.I. 37-S5 (page 289) for equipment authorized to operate on the NEC. Notes shown in parentheses in the location column are defined at the end of the table.

Location	Tracks				
	6	4	2	1	Other
New Haven Station (Metro North)	4	4	4	4	4
No. 6 trk adjacent to retaining wall (a)
No. 2 trk O.H. Br No. 71.60, Lamberton St . . . (a)
No. 1 trk O.H. Br No. 71.74, Howard Ave (a)
Between	Tracks				
	4	2	1	3	Other
New Haven & Mill River	5	5	5	5	...
Mill River & Shore Line Jct	...	4	4
Shore Line Jct & Davisville	5	5	5	5	...
No. 3 Trk between Stony Int and End of Track	4
Davisville & Malcolm	5	5
No. 4 Industrial Track	7
Malcolm Interlocking	7	5	5
Malcolm & Packard	...	7	5
Packard & Cranston	...	5	5	7	...
Cranston & Atwells	...	5	6	7	...
Atwells & Orms	4	4	4	...
No. 5 Track	4
No. 7 Track	7
Orms & Lawn (b)	...	5	5
No. 7 Industrial Track	7
Lawn & Boro (d)	5	5	5	5	...
Boro & Holden	6	5	5	5	...
Holden & Mansfield	...	6	6
Mansfield & Junction (e)	...	5	5
Junction & Read (c)	...	5	5
Read & Plains	...	4	4	5	...
Plains & Cove	...	4	4	4	...
Cove & Tower 1, all tracks	4	4	4	4	4
Notes:					
(a) The side mirror(s) must be folded closed against locomotive for movement on this track.					
(b) Plate F Cars measuring 17' 0" may operate between Lawn and West River Industrial Park switch on Track 2.					
(c) Plate F Cars measuring 17' 0" may operate between Transfer and Route 128 Industrial Park switch on Track 1.					
(d) Plate F cars measuring 17' 0" or less may operate on Trk 4 between Boro & Olive St OH Br, MP 196.72, but must not operate under Olive St OH Br.					
(e) Plate F and Plate G cars measuring 17' 0" may operate between Mansfield and the Merken's Chocolate Lead track.					

41-B1. DOUBLE STACK CARS – CLOSE CLEARANCE

Due to close clearance, operation of double stack cars (loaded or empty) is prohibited on No. 1 Track at New London.

41-B2. CARS EXCEEDING 263,000 POUNDS

Providence and Worcester Railroad (P&W) trains containing cars with a gross weight not exceeding 286,000 pounds may operate on all tracks between New Haven and Lawn (MP 188.6), except cars exceeding 263,000 pounds are prohibited over undergrade bridge MP 146.39 at Bradford, RI. **Note:** Cars operating on all other segments of the NHB Line are limited to 263,000 pounds, per SI 41-S2, page 305.

43-B1. CLOSE CLEARANCE - EMPLOYEES

(Protecting against personal injury – the following locations will not clear man on side of car)

- New Haven Yard Track – Track 39: The Fuel & Sand facility located on No. 39 track.
- Division Post (MP 72.9) to Boston: All high level passenger station platforms and locations where intertrack fences are erected between main tracks.
- MP 80.59: Between track 1 and cat poles 80-3 through 80-21 (nine structures)
- Saybrook: Fortune Plastics track (MP 104.7), and close clearance with signal case on Track No. 3 at crossover.
- Junction: The retaining wall adjacent to No. 2 track between Chapman St. OH Br MP 214.22 and Spaulding St. OH Br MP 214.33.

45-B1. PROVIDENCE STATION TUNNEL

Freight trains with HAZARDOUS MATERIALS cars in consist must not pass through Providence Station Tunnel area without first communicating with the Main Line Dispatcher. The Main Line Dispatcher must ensure there are no passenger trains operating within Providence Station tunnel and all passengers and employees have been cleared from platform area, prior to authorizing a freight train with HAZARDOUS MATERIALS cars to operate through the tunnel.

47-B1. ELECTRIC ENGINES: MAXIMUM NUMBER OF RAISED PANTOGRAPHS

When more than 2 consecutively coupled AEM-7 locomotives are moved in a train or lite engine consist, pantographs must not be raised on more than 2 locomotives.

47-B2. CATENARY DEAD SECTIONS

The following chart specifies the locations where dead sections are installed in the catenary system between New Haven and Boston. “Dead Section” signs (**black** signs with white letters “DS”) are installed 2 catenary poles before each dead section. “Approach Dead Section” signs (**yellow** signs with white letters “DS”) are installed on catenary poles approximately 15 seconds (based on maximum track speed) before each dead section.

In accordance with AMT-2 Instruction 3.302, Engineers of electric trains must have the throttle in the OFF position while operating through each dead section. In addition to this requirement, Engineers on ACS-64, AEM-7, HHP-8 and HST locomotives/power cars must have the Main Circuit Breaker (MB) switch in the OPEN position while operating through each dead section or voltage change location. Electric trains that stop with a raised pantograph in a dead section or voltage change location must contact the Dispatcher for instructions.

Location Relative to Nearest Station	Specific Location of Each Dead Section			Note
	Trk	West End	East End	
West of Mill River	2 & 4	MP 73.21	MP 73.30	1
	1 & 6	MP 73.17	MP 73.26	
West of Branford	2	MP 78.91	MP 78.98	...
	1	MP 78.93	MP 79.01	
West of Brook	2	MP 103.03	MP 103.13	...
	1	MP 103.06	MP 103.16	
West end Groton	1 & 2	MP 123.62	MP 123.66	2
East of High St	1 & 2	MP 150.10	MP 150.21	...
West of Cranston	1 & 2	MP 176.88	MP 176.99	...

47-B2. (Cont'd)

Location Relative to Nearest Station	Specific Location of Each Dead Section			Note
	Trk	West End	East End	
East of Holden	1 & 2	MP 198.92	MP 199.01	...
East of Sharon	1 & 2	MP 212.30	MP 212.42	...

Note 1: This dead section is also a catenary voltage change location from 12.5KV to 25KV.

Note 2: Dead Section Stop Signs (white sign with black letters "DS STOP") in service for eastbound electric trains on Tracks 1 and 2 at MP 123.41. To avoid an unnecessary stop in the dead section at Groton, **electric trains** operating with a **Restricting cab signal** or with **inoperative cab signals** must not pass this sign without permission of the Dispatcher. The Dispatcher must not give this permission until the home signal has been displayed at Groton, or the train has been given Rule 241 permission to pass the home signal in Stop position. Rule 241 permission may be given when the train is stopped at the Dead Section Stop Sign.

47-B3. MOVEABLE CATENARY UNIT

A Moveable Catenary Unit (MCU) is an apparatus of the catenary structure located on moveable bridges. An MCU allows the catenary structure to disconnect, and moves the catenary to a clear position. Employees whose duties require them to be on the bridge structure during operation must be aware of and take the necessary precautions to avoid injury due to the movement of the MCU. MCU's are now in operation on all moveable bridges.

47-B4. ELECTRIC ENGINES IN CONSIST

All trains, except scheduled Amtrak trains, must not operate with an electric engine in their consist without permission of the Train Dispatcher.

The Dispatcher must notify the connecting dispatching district, division or railroad of any trains operating with electric engines in consist other than scheduled Amtrak trains.

47-B5. NEW HAVEN PARCEL G

Employees who operate electric engines must not pass the sign on the Pit Track at Parcel G in New Haven without permission of the Mechanical Foreman. The sign is located to the right of the Pit Track.

72-B1. TRAIN INSPECTION DETECTORS

Type of Detector	Mile Post Location	Direction of Operation	Trk(s)	Recorder Location	Notes
RA HB/DED	79.0	East & West	1 & 2	East Haven	1
RA HB/DED	107.9	East & West	1 & 2	Soundview	1
RA HB/DED	127.8	East & West	1 & 2	Midway	1
RA HB/DED	154.3	East & West	1 & 2	Kenyons	1
RA HB/DED	168.7	East & West	1, 2 & 4	Davisville	1
RA HB/DED	183.5	East & West	3	Atwells	1
RA HB/DED	189.8	East & West	1, 2 & 7	Pawtucket	1
RA HBD	208.7	East & West	1 & 2	Hawk	1

Note 1: SI 72-S1 (page 313) applies.

72-B2. WHEEL IMPACT DETECTORS

Wheel impact detectors are installed at the following locations. See SI 72-S8.

MP	Location	Tracks	Notes
171.8	Rocky Hollow	1, 2	
201.5	Mansfield	1, 2	1

Note 1: Wheel Impact Load Detector on Track 2 equipped with Radio Alarm. See SI 72-S8.

92-B1. UNSCHEDULED TRAINS - TOWER 1

Unscheduled trains must not move up to the Tower 1 westward Home Signals (platform starter signals) without verbal permission from the Train Dispatcher.

94-B1. CALLING SIGNALS ON PUSH-PULL TRAINS

Rule 94(b) does not apply to push-pull trains operating in territory where Rule 562 is in effect (cab signals without fixed automatic block signals).

98-B1. NEW HAVEN: PARCEL G

Prior to moving equipment into or out of Parcel G, employees that have not worked in Parcel G within the preceding 6 months must have a documented job briefing with the Parcel G Operations Clerk. This job briefing may be held face to face or via telephone.

All movements operating in Parcel G New Haven must contact the Operations Clerk for permission and track assignments. The Operations Clerk can be reached via radio on either the Amtrak or the MNR radio channel, and also by ATS phone number 561-6161 or 561-6162.

A trainman, as designated by the Conductor, who is qualified on the Metro-North Operating Rules required for operating in Parcel G (see SI C-B1) and the physical characteristics of New Haven Terminal must ride all movements into and out of Parcel G. If the Engineer is on the leading end of the movement, the trainman must ride with the Engineer if at all possible.

98-B2. CONTROL OF YARD TRACKS

New Haven CDOT Shop - Car Shop and Locomotive Servicing Tracks

The following New Haven CDOT Shop tracks are designated Car Shop and Locomotive Repair Tracks. Authority of the employee named must be obtained before any movement is made. The Metro North Yardmaster may be contacted on channel 056-056. The Mechanical Foreman may be contacted on channel 056-056.

TRACKS	CONTROLLED BY
Tracks 24, 25, 26, 27, 27A, 29, 84, 85, and 47.	CDOT (S.L.E.) Mechanical Foreman
Tracks 21, 22 and 23 (west of CDOT Shop) - to the west derail.	CDOT (S.L.E.) Mechanical Foreman
All Other Tracks	Metro North Yardmaster

99-B1. FRA EXCEPTED TRACK—EAST LYME YARD

East Lyme Yard (MP 115.7) is FRA Excepted Track.

101-B1. MOVEMENT WITHIN NEW HAVEN CDOT SHOP AREA

An on-ground crew member must immediately precede all movements within the shop area (Tracks 24, 25, 26, & 27 within the building).

This employee must be prepared to stop the move should personnel enter the movement area unexpectedly.

101-B2. FOULING POINT OF A TRACK

In addition to the fouling points of a track as indicated by NORAC Rule 101 (b), a yellow fouling pole/marker is in service at the following location to identify the fouling points on adjacent tracks: Parcel G Yard.

104-B1. SWITCHES EQUIPPED WITH ELECTRIC LOCKS

The following hand-operated switches are equipped with an electric lock. Permission to occupy Main Track, Interlocking or Controlled Siding must be obtained from the Dispatcher before lock is removed from keeper.

Locations	Switch	Notes
MP 88.9	No. 1 trk to Whitfield Yard	2 & 3
MP 90.7	No. 1 trk to Landon Lumber	2 & 3
MP 95.7	No. 2 to Clinton Siding	2 & 3
MP 96.6	No. 2 to Clinton Siding	2 & 3
MP 96.6	No. 1 trk to Chesebrough Pond Co.	2 & 3
MP 97.5	No. 1 trk to Chesebrough Warehouse	2 & 3
MP 104.7	No. 3 trk to Fortune Plastic	...
MP 105.2	No. 3 trk to East Leg of Wye	7
MP 105.3	No. 3 trk to Tilcon Siding	...
MP 105.6	No. 2 track to Yard Trk. 6	...
MP 105.7	No. 3 trk to Tilcon Siding	...
MP 115.7	No. 1 trk to East Lyme Yard	...
MP 117.7	No. 2 trk to Millstone Point	...
MP 119.7	No. 2 trk to Hendell's	...
Shaws Cove	Facing point in No. 1 trk to Minor Alexander Ind. trk	1, 2, 5
New London	Trailing point (when operating east on No. 2 trk) connecting No. 2 trk to NEC Trk No. 6.	2, 3
Mystic River	No. 1 trk to Mystic Yard	5, 6
MP 141.7	No. 1 trk to Westerly Yard	...
MP 149.9	No. 2 trk to Hot Box Trk	2 & 3
MP 157.6	No. 1 Trk to Arnold Lumber Siding	2 & 3
MP 170.9	No. 1 trk to East Greenwich Yard	2 & 3
MP 174.5	No. 1 trk to Gannon Chemical	2 & 3
1000 feet east of MP 179	No. 3 trk to Wellington Siding (facing point when operating east)	...
645 feet west of MP 180	No. 3 trk to Wellington Siding (trailing point when operating east)	...
2972 feet west of MP 181	No. 3 trk to Spaulding Brick Co. (facing point when operating west)	...
MP 184.7	No. 7 trk to Yard 17 trk (ALCO sw)	...
MP 187.9	No. 2 trk to Patch	2 & 3
MP 193.8	No. 1 trk to Furmans Lumber	2 & 3
MP 193.9	No. 4 trk to East Jct Yard	2,3,8,9
MP 194.3	No. 4 trk to East Jct Branch	2 & 3
MP 197.9	No. 4 trk to Forte Fiber	2 & 3
MP 202.5	No. 1 trk to Zayre	2 & 4
MP 204.2	No. 1 track to Blaines Chemical	2 & 3
MP 204.2	No. 2 track to Merken's Chocolate	2 & 3
1637 feet east of MP 216	No. 1 trk to west end Rte 128 Ind Park	2 & 3
130 feet east of MP 217	No. 1 trk to east end Rte 128 Ind Park	2 & 3

104-B1. (Cont'd)

Note 1: Instructions for operation of switches will be posted in telephone box or at other convenient location adjacent to switch.

Note 2: To enter side trk from Main Trk, train must occupy trk circuit which extends 50 ft from point of switch, before switch can be opened.

Note 3: After permission has been obtained from the Dispatcher or Operator, switch lock may be removed as follows:

Depress treadle on electric lock to remove switch lock. After switch lock has been removed from keeper, approximately thirty (30) seconds must elapse before electric lock can be released.

After electric lock releases, step on bottom treadle to release handle of switch mechanism.

Switch lock must be replaced in keeper after switch is returned to normal position for restoration of signals.

Note 4: The requirements of **Note 3** apply, except a period of two minutes will elapse before the electric lock can be released.

Note 5: Controlled by Train Dispatcher on duty as listed in SI 900-B1.

Note 6: After permission has been obtained from the Dispatcher or Operator, switch lock may be removed as follows: Depress treadle on electric lock to remove switch lock. After lock is removed, request unlock from dispatcher on duty. Inform dispatcher when switch is reversed. After move is completed, inform dispatcher when switch is normal and padlocked.

Note 7: All independent derails must be in derailing position to unlock main trk switch & allow trk circuit to show unoccupied.

Note 8: To enter side trk from Main Trk, No. 4 Trk switch must first be opened to unlock hand operated split point derail switch, after which derail can be lined for train movement. After train is clear of derail, the derail must be restored to the derailing position before No. 4 Trk switch can be closed and locked.

Note 9: To leave side trk, Trk 4 switch must first be opened to unlock hand operated split point derail switch, after which derail can be lined for train movement. Derail must be restored to the derailing position before Trk 4 switch can be closed and locked.

104-B2. NORMAL POSITION OF SWITCHES AND CROSSOVERS AT SPECIFIED LOCATIONS:

Switch location	Connecting	With	Normal Position is for Movement	Note
West Class Yard	West Class Yard	Thorofare	Thorofare	...

119-B1. EXCESSIVE DIMENSION CARS

All cars exceeding Plate C are to be considered excessive dimension cars on the NHB Line. Train crews handling such cars must not occupy an Amtrak main track or running track until the Conductor or Engineer has communicated with the Dispatcher, and ensured that the Dispatcher has received the required restricted car information.

121-B1. INTERVENING TRACKS AT STATION PLATFORMS

The first two sentences of Rule 121B are modified as follows: Passenger trains approaching Branford Station, Madison, and Clinton that are routed to a track that will result in a station stop for receiving or discharging passengers across a main track must not enter the station without assurance from the Train Dispatcher that protection on the track adjacent to the station platform has been provided in accordance with Rule 121B. As a reminder of this requirement Rule 121B signs are installed approximately one mile prior to these stations.

132-B1. TRACKS AND SWITCHES OUT OF SERVICE

The tracks and switches listed below are out of service for train movements, except when such movements are personally supervised by an MW Foreman or MW Supervisor, or when movement consists entirely of track cars.

If a remotely controlled switch provides access to an affected track, the Operator or Dispatcher must apply blocking device protection to prevent the accidental routing of trains to that track. If a hand operated switch provides access to an affected track, the last Engineering Department employee to use the switch must spike the switch to prevent its accidental use.

Location	Track/Switch
Shore Line Jct	Thorofare
Branford Int	Branford Yard
MP 97.5	Chesebrough Warehouse
MP 103.7	Donnelly's
MP 105.6	Track 6
MP 119.7	Hendell's
Midway	Track 6
MP 141.7	Westerly Yard
Pawtucket Int	Turnkey Industrial Track
MP 193.8	Furman's Lumber
MP 204.2	Blaine's Chemical

138-B1. PUBLIC CROSSINGS AT GRADE

Column 1: Apparatus provided to automatically interrupt operation of highway crossing protection, including motion sensing detectors and/or predictors. Rule 138(g)(3) applies.

Column 2: Apparatus provided to interrupt operation of crossing protection manually by manipulation of a lever, plug or push button generally located on the signal control case close to the crossing.

Column 3: Circuitry will automatically interrupt crossing protection when switches, located within the activation circuit of the crossing, are reversed. After protection has been interrupted, trains must not occupy the crossing until the protection has been operating for at least 20 seconds, or if equipped with gates, they are in the horizontal position.

(Also, see S.I.'s 138-S1 & 138-S2, pgs 325 & 325)

MP	CROSSING	TRACKS	1	2	3	NOTES
120.2	Miner Lane	1 & 2	X	4
122.5	Bank St. Extension	1 & 2	X	X
122.8	State St.	1 & 2	...	X
		NECR Conn
123.0	Governor Winthrop Blvd	1 & 2	X	1
		NECR Conn	2
131.2	School St.	1 & 2	4, 5, 7
132.3	Broadway Extension	1 & 2	...	X	...	4, 7
133.4	Latimer Point Rd	1 & 2	...	X	...	4, 7
134.9	Wamphassuc	1 & 2	4, 7
136.6	Walkers Dock	1 & 2	...	X	...	3
136.7	Freemans Island	1 & 2	...	X	...	3
140.6	Palmer St.	1 & 2	X	X	...	4, 6, 7

138-B1. (Cont'd)

Note 1: Eastward trains making station stop at New London must stop west of CC sign located 740 feet west of MP 123.

Note 2: Color light dwarf signals in service on C.V. connection track 50 feet east and west of crossing. These are GATE INDICATOR signals for the crossing apparatus. After 30 seconds, if the yellow aspect is not displayed, trains must approach the crossing prepared to stop and must provide protection if gates are not horizontal.

Note 3: In conjunction with multiple whistle posts associated with Walkers Dock & Freemans Island, trains must sound one sequence of engine whistle signal 19(b) until the last crossing is occupied.

Note 4: "Smart crossing" equipped with 4 quadrant gates (a highway vehicle gate on each corner of the highway/rail intersection) and a vehicle detection system installed between the gates. Crossing is interconnected with the cab signal system and has the ability to downgrade the cab signals in accordance with Rule 553. When a train is approaching the crossing, the highway warning system will start to operate, causing the warning lights to flash and all gates to come down. If, within a predetermined distance and time, all gates are not down or the vehicle detection system does not show clear, the approaching train's cab signal will drop to Restricting immediately.

Note: **At School Street, the approaching train's cab signals will quickly downgrade one aspect at a time until it reaches Restricting.** Approaching trains receiving such downward cab signal changes must approach the crossing prepared to stop. If conditions change before the crossing is reached, the cab signal may change to a more favorable aspect, and trains will be governed by Rule 553. **Trains with inoperative cab signals must approach crossing prepared to stop, including trains operating on a Clear to Next Interlocking Signal, Rule 280a.**

Note 5: Westward trains making station stop at Mystic Station must stop east of "CC" sign located approximately 150 feet west of Broadway Extension, MP 132.3, or be governed by Train Dispatcher's instructions.

Note 6: Westbound trains stopping at Westerly Station must not exceed 70 MPH passing MP 142 and must not exceed 55 MPH between Westerly and Palmer St. Crossing.

Note 7: Designated a Quiet Zone.

138-B2. HIGHWAY CROSSING WARNING - GOV. WINTHROP BLVD (MP 123.0) (Track 6 - NECR Connection)

Due to a continuous rusty rail condition on Track 6 - NECR Connection at Gov. Winthrop Blvd MP 123.0, crews operating over this crossing on track 6 only must comply with the requirements in item 1 of Rule 138 part "c" - Stop, make certain that a crew member provides on-ground warning at the crossing, then proceed not exceeding 15 MPH until the leading end operates through the crossing.

175-B1. "80 MPH SLOW BY" SPEED RESTRICTION

In the application of SI 175-S2, the "80 MPH Slow By" speed restriction may be issued via TSRB in lieu of a Form D on the NHB Line.

When the speed restriction is issued by TSRB:

1. The restriction will apply to the entire train.
2. No start or end times for the restriction will apply.
3. The restriction will remain in effect until cancelled.

242-B1. IMPERFECTLY DISPLAYED SIGNALS

The most restrictive signal aspect of the signals described below is “Restricting”.

INTERLOCKING	DIRECTION / TRACK / LOCATION
Shaws Cove	Dwarf signal governing eastward movements on Track 6 (NECR Lead) at the east end of interlocking.
Stony	Signal governing westward movements on Track 3 at the west end of interlocking (at the “Begin/End Signal Territory” sign).
Malcolm	Signal governing westward movements on Track 4 at the west end of interlocking.
Pawtucket	Signal governing eastward movements on Track 4 at the east end of interlocking leading to the Pawtucket Layover Facility.

277-B1. MILL RIVER INTERLOCKING

A white arrow is in service on the eastward home signals on Nos. 1, 2, & 4 trks at Mill River. Illuminated arrow indicates that the route is lined to the Springfield Mainline.

Amtrak trains scheduled for the NHB Line must stop their train as soon as safe train handling will permit if the arrow signal is illuminated, and contact the Shoreline Dispatcher immediately for instructions.

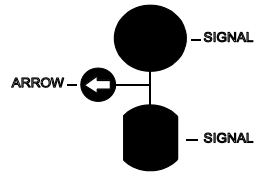

501-B1. SOUTH ATTLEBORO

In the application of Rule 501, westward trains that have received permission to return eastward from South Attleboro may increase speed to greater than Restricted Speed after the entire train has passed a location where a more favorable cab signal was received.

555-B1. FREIGHT TRAINS WITH INOPERATIVE CAB SIGNALS

Freight trains with inoperative cab signals must not exceed 30 MPH while operating under Rule 554 or 556. In territory where Rule 562 is in effect, freight trains with inoperative cab signals must not exceed 30 MPH while operating between the distant signal and the home signal to each interlocking, whether operating under Rule 280a (Clear to Next Interlocking signal), or Rule 563 (Form D Authorization for Movement in Rule 562 Territory).

580-B1. ACSES TERRITORY

ACSES Rules 580 through 591 (see SI 580-S1, page 338) are in effect on main tracks and controlled sidings between Mill River and Cove, as per SI 240-B1, page 105. The controlling engine of all trains operating in this territory must be equipped with operative on-board ACSES apparatus, except when failure occurs en route.

Note: Where data radio is not in service, temporary speed restrictions will be enforced by temporary transponders. The absence of temporary transponders where required must be reported to the Dispatcher.

583-B1. ACSES POSITIVE STOP: RADIO RELEASE

ACSES Positive Train Stop (PTS) radio release is in service for all interlocking home signals located within or adjacent to ACSES equipped territory.

586-B1. SHAWS COVE INT – REVERSING DIRECTION ON TRK 6 (NECR LEAD)

When an eastbound train will be reversing direction on Track 6 (NECR Lead) at New London, it must stop with its east end adjacent to Catenary Pole 122-126, in order to clear the ACSES transponder located east of the high level platform between Tracks 2 & 6.

When reversing direction on Track 6 to proceed west, the train must operate at least 5 MPH, but not exceeding 10 MPH, over the transponder in order to ensure that ACSES will indicate current wayside conditions, including enforcement of a Positive Stop when necessary at the westbound dwarf signal on Track 6.

900-B1. DISPATCHERS: ASSIGNED TERRITORIES

DISPATCHER	TERRITORY
Sunday 11:00 p.m. to Friday 11:00 p.m. <i>(See Notes for Modifications.)</i>	
Shore Line	Division Post MP 72.9 to Conn (exclusive).
New London	Conn (inclusive) to Mystic River (inclusive), except 3 p.m. to 11 p.m. Monday-Friday. <i>(See Weekday/Weekend Modifications and Note Below.)</i>
South County	Mystic River (exclusive) to Cranston (exclusive), except 3 p.m. to 11 p.m. Monday-Friday. <i>(Off-duty Monday-Friday 3p.m. to 11p.m.)</i>
Main Line	Cranston (inclusive) to Junction (exclusive) except 3 p.m. to 11 p.m. Monday-Friday. <i>(See Weekday/Weekend Modifications and Note Below.)</i>
Corridor	Junction (inclusive) to Cove (exclusive).
Terminal	Cove (inclusive) to Boston (South Station). <i>(See Weekend Modification.)</i>
Weekday Modifications: Monday – Friday 3 p.m. to 11 p.m.	
New London	Conn (inclusive) to Kingston (exclusive).
South County	Off-Duty
Main Line	Kingston (inclusive) to Junction (exclusive).
Weekend Modifications: Friday 11 p.m. to Sunday 11 p.m. *	
Shoreline	Division Post MP 72.9 to Mystic River (inclusive).
<i>New London</i>	<i>May Work Conn (inclusive) to Mystic River (inclusive). See Note*</i>
<i>South County</i>	<i>May Work Mystic River (exclusive) to Cranston (exclusive). See Note*</i>
Main Line	Mystic River (exclusive) to Junction (exclusive).
Corridor	Junction (inclusive) to Cove (exclusive).
Dorchester	Cove (inclusive) to Boston (South Station).
<i>Terminal</i>	<i>(Territory controlled by Dorchester Dspr)</i>
* Note: During periods of construction, the New London and/or South County Dispatchers may work on weekends. Trains and personnel working between Cranston and Conn between 11p.m. Fridays and 11p.m. Sundays should contact the dispatching office to verify the Dispatcher's assigned territory.	

***This
Page
Intentionally
Left
Blank***

DORCHESTER BRANCH

STATIONS	MP	INT	PS	NOTES
TRANSFER R-Corridor TD (Main Line-New Haven to Boston)	218.5	X
HILL R-MBCR Branch Line TD (Franklin Branch)	219.1	X
DANA R-MBCR Branch Line TD	219.5	X
FAIRMOUNT	220.5	...	X	...
MORTON STREET	223.0	...	X	...
PARK	224.3	X
UPHAMS CORNER	225.8	...	X	...
SOUTH BAY R-Dorchester TD	227.0	X
LOOP R-Dorchester TD (Amtrak Runner)	227.4	X	...	1
BROAD R-Dorchester TD	227.6	X	...	2
TOWER 1 R-Terminal TD (Main Line-New Haven to Boston)	228.0	X	...	3

Mile Post distances are measured from New York, GCT (MNR).

The direction from Tower 1 to Transfer is West.

MBCR territory between Transfer and South Bay shown as information only.

Note 1: Running track "Amtrak Runner" extends from switch to Southampton St. Yard Lead to the west limits of Loop. The Dorchester Train Dspr is in charge of Amtrak Runner.

Note 2: Equipped with moveable point frogs. See SI 80-S1.

Note 3: Equipped with slip switches. See SI 80-S1.

240-D1. SIGNAL RULES and CURRENT OF TRAFFIC.

On tracks where Rule 261 is in effect, ABS Rules and CSS Rules 550 through 561 are in effect for movements in both directions.

Int. indicates interlocking rules in effect.

Between	Tracks from South to North		Notes
	2	1	
Tower 1 & Broad	261	261	1. 2
Between	2	1	Notes
Broad & South Bay	261	261	1
Broad & Loop: Tracks 10 & 12	Int		...

Note 1: CSS Rules not in effect.

Note 2: Interlocking Rules in effect on Station tracks 1 through 13 between Tower 1 and Boston. Station tracks 1 through 13 are designated Main tracks.

37-D1. PASSENGER TRAINS and FREIGHT TRAINS MAXIMUM SPEEDS and SPEED RESTRICTIONS, UNLESS OTHERWISE RESTRICTED

Locations and speeds shown in normal type are maximum authorized speeds. Locations and speeds shown in bold type are speed restrictions. Where speeds change at an interlocking and the specific point where the speed change occurs is not specified, the lower speed will apply through the entire interlocking.			
PASSENGER TRAINS			
Between/At	Tracks		
	No. 1	No. 2	Other
West Limits South Bay & Broad	25	20	...
Loop & Broad: Tracks 10 & 12	15
Broad & West Limits Tower 1	15	15	...
West Limits Tower 1 & Boston	All Tracks 10 MPH		
FREIGHT TRAINS			
Between/At	Tracks		
	No. 1	No. 2	Other
West Limits South Bay & Broad	25	20	...
Loop & Broad: Tracks 10 & 12	5
Broad & West limits Tower 1	5	5	...
West Limits Tower 1 & Boston	All Tracks 10 MPH		

1-D1. BOSTON TERMINAL OPERATIONS NOTICE

Boston Terminal Operations Notices (BTON) will be issued as required, and will be numbered sequentially, the number being suffixed by the last two digits of the calendar year. The number of the most recent BTON will be published at the top of the Bulletin Order.

All yard employees working in Southampton Street Yard and Protect Crews reporting at South Station must read and retain a copy of the BTON. Road Crews must read these instructions, but are not required to carry them while on duty.

4-D1. JOB BRIEFINGS – SOUTHAMPTON ST. YARD

Before performing yard service in Southampton Street Yard, extra board employees that have not performed yard service within the preceding 20 days must attend a documented job briefing with the Yardmaster.

16-D1. BLUE SIGNAL DERAILS

The following locomotive and car shop repair tracks are equipped with hand-operated blue signal derails:

Southampton Street Yard Locomotive and Coach Repair Facility and Service and Inspection Facility

Nos. 1, 2, & 3 Shop Tracks.

Nos. 4 & 5 Service and Inspection Building Tracks.

High Speed Rail Maintenance Facility:

Nos. 6 & 7 HSR Tracks

20-D1. SOUTHAMPTON ST. MBTA S&I BUILDING

The engine bell must be rung while approaching and passing over the crossings at the east and west ends of the S&I building.

36-D1. SOUTHAMPTON STREET YARD – WET LOOP TRAINWASH FACILITY

Trains operating through the train wash facility will be governed by the following procedure:

1. Westbound:

Trains will be spotted adjacent to the L22 catenary pole. An amber **XX** will illuminate on the LED indicator on the building to the right of the doors. Approximately 30 seconds will pass to allow the doors to cycle open, and for the wash apparatus to activate fully. Trains may proceed through the wash building when all of the following conditions are met:

- 1) The amber **XX** changes to a solid or flashing* green “**GO**”.
- 2) The doors are open.
- 3) The track ahead is seen to be clear of equipment.

* **Notes:** A **solid** green **GO** indicates the wash apparatus is functioning normally and the doors are fully open.

A **flashing** green **GO** indicates the wash is apparatus not functioning, but the doors are fully open. If a flashing green **GO** is indicated, report it to the yardmaster. If the indicator continues to display amber **XX**, displays an indication other than a flashing or solid green **GO**, or the indicator is dark, do not proceed into the wash building until contacting the yardmaster for instructions. Trains operating through the wash will proceed at Restricted Speed not exceeding **5 MPH** until clear of the wash building. Actual train speed will be shown on LED indicators to the right of the track when operating under the solid green **GO**. The LED indicators will **NOT** indicate speed when operating under a flashing green **GO** or any other indication. Speed will indicate up to 5.1 mph at which point the wash will shut down and speed display will go dark.

2. Eastbound:

When the front axle passes over a sensor located 800 feet west of the building, a signal will be sent to the LED sign on the west end to activate, and a solid or flashing green **GO** will be indicated. If the signal request fails to activate the LED sign, the train may continue to the sensor located 40 feet from the building, and a request will again be sent to the LED sign to indicate a solid or flashing green **GO**. The train may proceed with a solid or flashing green **GO** at Restricted Speed not exceeding **5 MPH** until clear of the wash building.

The train wash apparatus will not function in this direction, and there are no speed indicators eastbound. If the LED sign does not indicate a solid or flashing green **GO**, do not proceed into the wash building until contacting the yardmaster for instructions.

Trains must not reverse direction in the wash building while the wash apparatus is operating. If the wash apparatus is **not** operating, contact the yardmaster prior to any reverse movement in the building.

37-D2. MAXIMUM SPEEDS-OTHER TRACKS

Location	Tracks	Restricted Speed not Exceeding
Between Loop & South Bay	Wet Loop & Dry Loop	5 MPH
Loop	Amtrak Runner	5 MPH
Southampton St. Yard	All Tracks	5 MPH
Between Broad & Cove	Wye Connector	10 MPH

37-D3. SPEEDOMETER CHECKING: MEASURED MILES

The distance between MP 222 and MP 223 is a measured mile. White marker posts are installed on both sides of the tracks at these locations.

40-D1. ENGINE AND EQUIPMENT RESTRICTIONS

The numbers shown in the columns to the right of each listed location specify the maximum height of the engines and equipment that may be operated. Engine and equipment dimension specifications are assigned in S.I. 37-S5 (page 289) for equipment authorized to operate on the NEC.

Notes shown in parentheses in the location column are defined at the end of the table.

Location	Tracks		
	2	1	Other
Tower 1 & Broad, all tracks	4	4	4
Broad & West Limits South Bay	5	5	...
Southampton Street Yard, all tracks	5
High Speed Rail S&I Building, trks 6 & 7	2
Conventional Equipment S&I Building, Tracks 4 & 5 (a)	3

Note:
(a) Amtrak Non-Powered Control Units 406, 90200-90415 & GP38 H-3 engines 520-527 may operate on tracks 4 & 5.

43-D1. SOUTHAMPTON ST. YARD: CLOSE CLEARANCE

A number of catenary poles in Southampton Street Yard have limited clearance and will not clear an employee on side of car. All employees must use caution when working in this area.

98-D1. CONTROL OF YARD TRACKS

1. Southampton St. Yard - Car Shop and Locomotive Servicing Tracks

The following Southampton St. Maintenance Facility tracks are designated Car Shop and Locomotive Repair Tracks. Authority of the employee named must be obtained before any movement is made. The Yardmaster may be contacted on channel 023-023, the Mechanical Foreman may be contacted on channel 042-042, and the High Speed Rail Foreman may be contacted on channel 095-095. Prior to authorizing movement into the HSR maintenance building on track 7, the High Speed Rail Foreman must ensure that the track is unobstructed and otherwise secured for movement. Speed passing over the drop table on track 7 must not exceed 2 MPH.

TRACKS	CONTROLLED BY
Tracks 1, 2 & 3 between the hand-operated blue signal derails located at the east and west ends of the Locomotive and Coach Repair Shop	Mechanical Foreman, Southampton St. Yard
Tracks 4 & 5 between hand-operated blue signal derails located approximately 75 feet west of the Service and Inspection building to hand-operated blue signal derails located approximately 50 feet east of the Service and Inspection building.	Mechanical Foreman, Southampton St. Yard
Tracks 6 & 7 between hand-operated blue signal derails located approximately 25 feet on either side of the High Speed Rail Maintenance Building.	Foreman, High Speed Rail, Southampton St. Yard

2. Yardmaster

The Yardmaster is in charge of movements on all other tracks in Southampton St. Yard (See SI 104-D3).

101-D1. MOVEMENT WITHIN SHOP AREA

An on ground crew member must immediately precede all movements within the shop area (tracks 1, 2 & 3 within the building) in Southampton Street Yard. This employee must be prepared to stop the move should personnel enter the movement area unexpectedly. Additionally, all movements made over the wheel machine on Shop Track 3 must be observed by a second crew member standing adjacent to the wheel machine. Speed passing over the wheel machine must not exceed 2 MPH. Special Instruction 116-S1, paragraph C does not apply to these moves.

104-D1. NORMAL POSITION OF SWITCHES AND CROSSOVERS AT SPECIFIED LOCATIONS

Switch location	Connecting	With	Normal Position is for Movement	Note
South Bay Psgr. Yard, East End Wet Loop, 250 ft. west of Loop	Wet Loop	Regular Loop	To Wet Loop	...

104-D2. DOUBLE SLIP SWITCHES EQUIPPED WITH MOVEABLE POINT FROG

No movements are permitted to operate over the crossover/double slip switches with moveable point frog, located at the west end of the MBTA S&I building, without receiving a hand signal to proceed from the switchtender on duty, or visually confirming that the route is properly lined prior to movement over the switch.

104-D3. SOUTHAMPTON ST YARD: ENTERING & LEAVING

The Southampton Street Yardmaster is in charge of all movements at the following locations:

1. Within Southampton Street Yard. This extends from the eastern fouling points of the diamond at the east end of the yard to the western limits of the yard, including the "Chute" track,
2. The 15 switch lead from the diamond to the Home Signal at South Bay,
3. The 31 switch lead from the double slip switch to the Home Signal at Cabot.

When on duty, the switch tenders at the double slip switches located at the east end of the yard report to and receive their instructions from the Southampton Street Yardmaster.

The Yardmaster may designate that these switch tenders coordinate movements on the east end of the yard. The two switch tenders must communicate between themselves to prevent conflicting movements within this area.

When train crews receive a release on their trains from the Yardmaster and are ready to leave the yard, they must call the Dorchester Train Dispatcher to obtain permission to leave Southampton Street Yard.

All movements made from the west end of the MBTA service facility tracks must obtain permission from the switch tender, or yardmaster when no switch tender is on duty, before moving west into Amtrak controlled territory.

119-D1. EXCESSIVE DIMENSION CARS

All cars exceeding Plate C are to be considered excessive dimension cars on the DB Line. Train crews handling such cars must not occupy an Amtrak main track or running track until the Conductor or Engineer has communicated with the Dispatcher, and ensured that the Dispatcher has received the required restricted car information.

138-D1. GRADE CROSSINGS WITH AUTOMATIC PROTECTION AND/OR SPECIAL REQUIREMENTS

Grade crossing equipped with automatic warning devices in service at east end of Southampton St. MBTA S&I Building (MP 227.3) on Nos. 1 and 2 tracks Dorchester Branch. This crossing is designated "MBTA S&I East Crossing," and is located within the limits of Loop (*see S.I. 138-S2, pg 325*).

138-D2. SOUTHAMPTON ST YARD: ROAD CROSSINGS

Trains operating on yard tracks in Southampton Street Yard must approach all road crossings prepared to stop.

138-D3. SOUTHAMPTON ST YARD: WEST END ACCESS

A train approach activated strobe light is installed at the West End Crossing of the Commuter S&I Building. The system consists of a yellow strobe light that will flash and a low volume buzzer that activates upon the approach of a train. This warning system is only an enhancement to normal personal attention required to utilize this crossing. Employees must use caution when working in this area and adhere to the practice of stopping, looking, and listening prior to crossing the tracks.

138-D4. PUBLIC CROSSINGS AT GRADE

MP	CROSSING	TRACKS	NOTES
227.0	Widett Circle	Wet & Dry Loop Tracks	1

Note1: Rule 138(g)(2) applies: A train must not foul the crossing until it is ascertained that the warning devices have been operating for at least 20 seconds. If the automatic highway crossing warning is not operating, the movement must not be made until warning is provided by on-ground personnel. Notification must be made to the Dorchester Dispatcher in accordance with S.I. 138-S4.

706-D1. RADIO CHANNELS

Within Southampton Street Yard, the following radio channels must be used:

Movements on Amtrak Runner: Channel 092-092.

Switching operations: Channel 023-023.

Mechanical Department operations: Channel 035-035.

900-D1. DISPATCHERS: ASSIGNED TERRITORIES

DISPATCHER	TERRITORY
Terminal	Boston (South Station) to Tower 1 (inclusive).
Dorchester	Tower 1 (exclusive) to South Bay (inclusive).
MBCR Branch Line	South Bay (exclusive) to Transfer (exclusive).
<i>Weekend Modifications—From 11:00 PM Fridays through 11:00 PM Sundays:</i>	
Dorchester	Boston (South Station) to South Bay (inclusive).

MIDDLEBORO MAIN LINE (MM)

STATIONS		MP	INT	PS	NOTES
BOSTON	(South Station)	0.0	...	X	...
TOWER 1	R-Terminal TD	0.2	X	...	2
BROAD	R-Dorchester TD	0.6	X	...	1
LOOP	R-Dorchester TD	0.8	X	...	1
CABOT	R-Dorchester TD	1.0	X

The direction from Boston to Cabot is West.

Mile Post distances are measured from Boston.

Note 1: Interlocking rules apply on Track 14 only.

Note 2: Equipped with slip switches. See SI 80-S1.

240-01. RULES IN EFFECT

On tracks where Rule 261 is in effect, ABS Rules and CSS Rules 550 through 561 are in effect for movements in both directions.

Between	Tracks from North to South		Notes
	14	16	
Tower 1 & Cabot	261	261	1

Note 1: CSS not in effect.

37-01. PASSENGER TRAINS and FREIGHT TRAINS MAXIMUM SPEEDS and SPEED RESTRICTIONS, UNLESS OTHERWISE RESTRICTED

Locations and speeds shown in normal type are maximum authorized speeds. Locations and speeds shown in **bold type** are speed restrictions.

Where speeds change at an interlocking and the specific point where the speed change occurs is not specified, the lower speed will apply through the entire interlocking.

Where two speeds separated by a diagonal line are shown, the higher speed applies to equipment authorized to exceed 90 MPH, and the lower speed applies to equipment not authorized to exceed 90 MPH.

PASSENGER TRAINS			
Between/At	Tracks		
	No. 14	No. 16	Other
Boston & West Limits Tower 1	All Tracks 10 MPH		
Fort Point Channel UG Br MP 227.9	15	15	..
West Limits Tower 1 & Cabot	30	30	...
FREIGHT TRAINS			
Between/At	Tracks		
	No. 14	No. 16	Other
Boston & West Limits Tower 1	All Tracks 10 MPH		
Fort Point Channel UG Br MP 227.9	10	10	...
West Limits Tower 1 & Cabot	20	20	...

20-01. ENGINE BELL: LOOP TO CABOT

The engine bell must be sounded continuously between Loop and Cabot.

900-01. DISPATCHERS: ASSIGNED TERRITORIES

DISPATCHER	TERRITORY
Terminal	Boston (South Station) to Tower 1 (inclusive).
Dorchester	Tower 1 (exclusive) to Cabot (inclusive).
<i>Weekend Modifications—From 11:00 PM Fridays through 11:00 PM Sundays:</i>	
Dorchester	Boston (South Station) to Cabot (inclusive).

MAIN LINE-MILL RIVER TO SPRINGFIELD (MRS)

STATIONS	MP	INT	PS	NOTES
MILL RIVER R-Shore Line TD (Main Line-New Haven to Boston)	1.5	X
CEDAR R-Springfield Line TD (North Haven Thorofare CSX)	7.0	X
WALLINGFORD	12.6	...	X	...
CP WALL R-Springfield Line TD	13.3	1
HOLT R-Springfield Line TD	17.1	X
MERIDEN	18.6	...	X	2
QUARRY R-Springfield Line TD	20.6	X
BERLIN	25.9	...	X	...
NEW R-Springfield Line TD	31.1	X
WOOD R-Springfield Line TD	33.4	X
HARTFORD	36.6	...	X	...
HART R-Springfield Line TD (Hartford Running Track)	37.2	X	...	3
FRY (Hartford Running Track)	38.9	3
WINDSOR STATION	42.9	...	X	...
WINDSOR R-Springfield Line TD	43.0	X
HAYDEN R-Springfield Line TD	46.3	X
WINDSOR LOCKS	47.4	...	X	...
FIELD R-Springfield Line TD	54.7	X
STATE LINE (Conn.-Mass.)	55.8
SWEENEY R-Springfield Line TD	61.7	X
SPRING R-Springfield Line TD (Boston Line CSX)	62.0	X
SPRINGFIELD	62.0	...	X	...

Mile Post distances are measured from New Haven.
The direction from Mill River to Springfield is northward.

Note 1: Northward and Southward controlled signals.

Note 2: Rule 121(c) applies on No. 2 track.

Note 3: Hartford Running Track controlled by Springfield Line TD.

240-M1. SIGNAL RULES and CURRENT OF TRAFFIC

On tracks where Rule 261 is in effect, ABS Rules and CSS Rules 550 through 561 are in effect for movements in both directions.

Between	Tracks from East to West			Notes
	2	1	Single	
Mill River & Cedar	261	261
Cedar & Holt	261	...
Holt & Quarry	261	261
Quarry & New	261	...
New & Wood	261	261
Wood & Windsor	261	...
Windsor & Hayden	261	261
Hayden & Field	261	...
Field & Sweeney	261	261

240-M1. (Cont'd)				
Between	Tracks from East to West			Notes
	2	1	Single	
Sweeney & CP98 (CSX)	...	261	...	1
Sweeney & Spring	261

Note 1: On Track 10, Rule 261 & ABS Rules in effect, CSS not in effect.

37-M1. PASSENGER TRAINS and FREIGHT TRAINS MAXIMUM SPEEDS and SPEED RESTRICTIONS, UNLESS OTHERWISE RESTRICTED

Locations and speeds shown in normal type are maximum authorized speeds. Locations and speeds shown in **bold type** are speed restrictions. Where speeds change at an interlocking and the specific point where the speed change occurs is not specified, the lower speed will apply through the entire interlocking.

PASSENGER TRAINS			
Between/At	Tracks		
	Single	No. 1	No. 2
Mill River & MP 3	...	60	60
Nos. 3 & 5 trks. Mill River Int.			35 MPH
MP 3 & Cedar	...	80	80
Cedar & Holt	80
Ward St. and Parker St.	25
Holt & MP 18	...	60	60
MP 18 & MP 19.5	...	25	25
MP 19.5 & Quarry	...	80	80
Quarry & New	80
New & Wood	...	80	80
Wood & MP 36	80
MP 36 & Hart	20
Hart & Windsor	80
Windsor & Hayden	...	80	80
Hayden & MP 47	80
MP 47 & MP 49	50
Over Bridge St crossing MP 48.5 (4:15 PM to 4:45 PM only)	30
MP 49 & Field	80
Cvs-Br MP 49.3 & MP 50.5	35
Cvs MP 53.7 & Field	70
Field & MP 59	...	80	80
MP 59 & MP 61	...	60	60
Cv MP 59.1 & 59.6	...	45	45
MP 61 & Sweeney	...	20	20
Sweeney & CP98 (CSX)	...	10	...
Track 10			10 MPH
Sweeney & Springfield Station	10

37-M1. (Cont'd)			
FREIGHT TRAINS			
Between/At	Track		
	Single	No. 1	No. 2
Mill River & MP 3	...	30	30
Nos. 3 & 5 trks. Mill River Int.			20 MPH
MP 3 & Cedar	...	50	50
Cedar & MP 9	40
MP 9 & Holt	50
Ward St. and Parker St.	25
Holt & MP 18	...	30	30
MP 18 & MP 19.5	...	25	25
MP 19.5 & Quarry	...	40	40
Quarry & Signal 29.4	50
Signal 29.4 & New	45
New & Wood	...	30	30
Wood & MP 36	50
MP 36 & Hart	10
Hart & Signal 41.4	50
Signal 41.4 & Windsor	45
Windsor & Hayden	...	40	40
Hayden & MP 47	50
MP 47 & MP 49	30
Over Bridge St crossing MP 48.5 (4:15 PM to 4:45 PM only)	30
MP 49 & Signal 53.0	50
Conn River Br MP 49.7 & MP 50	10
Cvs-Br MP 49.3 & MP 50.5	30
Signal 53.0 & Field	45
Cvs MP 53.7 & Field	30
Field & MP 59	...	50	50
MP 59 & MP 61	...	40	40
MP 61 & Sweeney	...	20	20
Sweeney & CP98 (CSX)	...	10	...
Track 10			10 MPH
Sweeney & Springfield Station	10

A-M1. PAN AM TIMETABLE: SPRINGFIELD

Amtrak Train and Engine service employees who turn (wye) their equipment at Pan Am's CPR1 interlocking will not be required to carry the Pan Am System Timetable. Such movements will be governed by signal indication, must not exceed 10 MPH, and may contact the Pan Am Dispatcher District #3 who controls CPR1 on radio channel 9470 or at 800-955-9207. If unable to reach the Pan Am Dispatcher, notify the Amtrak Springfield Line Dispatcher or Boston Chief Dispatcher.

This Special Instruction does not relieve Amtrak employees from meeting Pan Am's requirements for qualifying on the physical characteristics of the territory involved.

34-M1. IDLING AND SHUTTING DOWN DIESEL LOCOMOTIVES: SPRINGFIELD

Locomotive head end power may only be generated in the normal position while detraining passengers, while engaged in turning the train and immediately prior to departure. Stand-by position will be used for boarding passengers 10 minutes prior to leaving time and while waiting for a signal while turning the train.

While in the station, the following will apply:

If the ambient temperature is above 45 degrees, engines may idle only in the low idle position for no longer than 30 minutes, after which they must be shut down.

If the ambient temperature is below 45 degrees, engines may be idled continuously, but only in the low idle position.

When changing the mode of power on the head end power panel, the “stop” button must be pushed first, then switches positioned for the desired mode prior to pressing “start” button.

36-M1. SWEENEY: STOPPING LOCATION

Locomotives must not be stopped under Memorial Street Bridge, MP 61.43.

37-M2. SPEEDOMETER CHECKING: MEASURED MILES

The distance between the sets of Mile Posts listed below is a measured mile. White marker posts are installed on both sides of the tracks at locations marked with an asterisk (★).

★MP 3- ★MP 4	★MP 15- ★MP 16	★MP 32- ★MP 33	★MP 57- ★MP 58
--------------	----------------	----------------	----------------

37-M3. MAXIMUM SPEEDS-RUNNING TRACKS

Track	Between	And	Restricted Speed not exceeding
Hartford Running	Hart	Fry	10

37-M4. MAXIMUM SPEEDS-OTHER TRACKS

Location	Tracks	Restricted Speed not exceeding
Between Mill River & Springfield	All industrial Tracks	10 MPH
Springfield Station	2A, 4, 6, & 8	5 MPH

40-M1. ENGINE AND EQUIPMENT RESTRICTIONS

The numbers shown in the columns to the right of each listed location specify the maximum height of engines and equipment that may be operated. Engine and equipment dimension specifications are assigned in S.I. 37-S5 (page 289) for equipment authorized to operate on the NEC.

Notes shown in parentheses in the location column are defined at the end of the table.

Location	Tracks			
	2	1	Single	Other
Mill River & Cedar	5	5
Cedar & Spring	6	6	6	...
Hartford: Station Viaduct Bridge (a)

Note: (a) Engines and loads exceeding 290,000 pounds gross weight must not exceed 15 MPH.

43-M1. CLOSE CLEARANCE – EMPLOYEES

(Protecting against personal injury – the following locations will not clear man on side of car.)

- ▶ Springfield Station - Tracks 2a, 4, 6, 8, Stub-8, and the Lead.
- ▶ All high level passenger station platforms.

72-M1. TRAIN INSPECTION DETECTORS

Type of Detector	MP Location	Direction of Operation	Track(s)	Recorder Location	Notes
RA HB/DED	24.4	North & South	Single	Berlin	1
RA HB/DED	40.2	North & South	Single	Windsor	1

Note 1: SI 72-S1 (page 313) applies.

72-M2. WHEEL IMPACT DETECTORS

Wheel impact detectors are installed at the following locations. See SI 72-S8.

MP	Location	Tracks
51.5	Enfield	Single

104-M1. NORMAL POSITION OF SWITCHES AND CROSSOVERS AT SPECIFIED LOCATIONS

Switch Location	Connecting	With	Normal Position is for Movement	Note
Air Line Jct Yard	Air Line Yard Lead	Old Main & Hill Tracks	To Old Main Track	1
Hartford Running Trk.	Hartford Running Trk.	Hartford Yard	None	2
Springfield	Track 6	Track 8	Trk 6 to Trk 8	...

Note 1: Westward movements must obtain permission from the Shore Line TD before occupying the Air Line Yard Lead.

Note 2: Switches at the north and south ends of Hartford Running Track providing access to Hartford Yard may be left lined for movements in either direction.

104-M2. SWITCHES EQUIPPED WITH ELECTRIC LOCKS

The following switches are equipped with an electric lock. Permission to remove the padlock from the keeper must be obtained from the Dispatcher.

Location	Track	Switch	Notes
MP 2.6	No.1	Facing point to Hartford Siding Ind.	1, 2
MP 3.2	No. 2	Trailing Point to Welded Rail Plant	1, 2
MP 19.4	No. 2	Trailing point to Meriden Yard	...
MP 21.6	Single	Trailing point to Quarry Industrial	...
MP 26.4	Single	Trailing point to Berlin Industrial	...
MP 26.9	Single	Trailing point to Connecticut Waste Processing Mgmt	...
MP 26.4	Single	Trailing point to ST RR	...
MP32.4	No. 2	Facing point to Standard Steel	1,2
MP33.2	No. 2	Facing point to Fernwood Yard	1, 2
MP 35.2	Single	Trailing point to Parkville Industrial	...
MP36.2	Single	Trailing point to Hartford Courant	1, 2
MP 37.0	Single	Trailing point to New Britain Industrial	...
MP 38.9	Single	Trailing point to Hartford Running Track	...
MP 48.7	Single	Facing point to South End Windsor Locks yard	...
MP 49.1	Single	Facing point to Suffield Industrial	...
MP 61.4	No. 2	Facing point to No. 6 (Mail Track)	...

(Notes on next page)

104-M2. (Cont'd)

Note 1: To enter side track from Main Track, train must occupy track circuit which extends 50 feet from point of switch, before switch can be opened.

Note 2: After permission has been obtained from the Dspr or Opr, switch lock may be removed as follows:

Depress treadle on electric lock to remove switch lock. After switch lock has been removed from keeper, approximately thirty (30) seconds must elapse before electric lock can be released.

After electric lock releases, step on bottom treadle to release handle of switch mechanism.

Switch lock must be replaced in keeper after switch is returned to normal position for restoration of signals.

119-M1. EXCESSIVE DIMENSION CARS

Cars not exceeding Plate F may move on the MRS Line between Springfield (MP 62.0) and Cedar (MP 7.0).

All cars exceeding Plate C moving from Mill River (MP 1.5) and Cedar (MP 7.0) must be considered excessive dimension cars on the MRS Line. Train crews handling such cars must not occupy an Amtrak main or running track when moving between Mill River and Cedar, until the Conductor or Engineer has communicated with the Dispatcher, and ensured that the Dispatcher has received the required restricted car information.

132-M1. TRACKS AND SWITCHES OUT OF SERVICE

The tracks and switches listed below are out of service for train movements, except when such movements are personally supervised by an MW Foreman or MW Supervisor, or when movement consists entirely of track cars.

If a remotely controlled switch provides access to an affected track, the Operator or Dispatcher must apply blocking device protection to prevent the accidental routing of trains to that track. If a hand operated switch provides access to an affected track, the last Engineering Department employee to use the switch must spike the switch to prevent its accidental use.

Location	Track/Switch
MP 19.4	Meriden Yard
MP 36.3	Hartford Courant Switch and Siding
MP 61.7	Roadrailer Track

138-M1. PUBLIC CROSSINGS AT GRADE

Column 1: Apparatus provided to automatically interrupt operation of highway crossing protection, including motion sensing detectors and/or predictors. Rule 138(g)(3) applies.

Column 2: Apparatus provided to interrupt operation of crossing protection manually by manipulation of a lever, plug or push button generally located on the signal control case close to the crossing.

Column 3: Circuitry will automatically interrupt crossing protection when switches, located within the activation circuit of the crossing, are reversed. After protection has been interrupted, trains must not occupy the crossing until the protection has been operating for at least 20 seconds, or if equipped with gates, they are in the horizontal position.

(Also, see S.I. 138-S2, pg 325)

MP	CROSSING	TRACKS	1	2	3	NOTES
3.2	Benton St	1 & 2	...	X	X	...
5.1	Winchesters	1 & 2	...	X	X	...
5.8	Sackett Point Rd	1 & 2	...	X	X	...
6.3	Stiles Lane	1 & 2	X	X	X	1

138-M1. (Cont'd)

MP	CROSSING	TRACKS	1	2	3	NOTES
6.5	Devine St	1 & 2	X	X	X	1
10.6	Toelles Rd	Single	...	X	X	...
12.3	Ward St	Single	X	...	X	3
12.6	Quinnipiac St	Single	...	X
12.7	Hall Ave	Single	...	X
13.1	Parker St	Single	X	X	...	2
		Yard
13.8	North Plains Highway	Single	...	X	X	...
14.5	Pent Highway	Single	...	X	X	...
18.3	Cooper St	1 & 2	...	X
18.5	South Colony St	1 & 2	X	4
18.6	East Main St	1 & 2	X	4
18.8	Brook St	1 & 2	...	X
19.0	Cross St	1 & 2	...	X
19.4	Brittania St	1 & 2	X	X	X	7, 8
19.5	North Colony St	1 & 2	X	X	X	7, 8
33.6	Oakwood Ave	Single	X	X
		Industrial
35.0	Hamilton St	Single	...	X
		Industrial
39.7	Meadow Rd	Single	X	...
39.9	Wilson Ave	Single	...	X
40.2	East Barber St	Single
42.3	Island Rd	Single
42.9	Central St	Single
43.6	Pierson Lane	1 & 2	...	X
45.1	Macktown Rd	1 & 2	...	X
45.7	Hayden Station Rd	1	X	X	X	...
		2	...	X
48.1	Dexters	Single
48.5	Bridge St	Single	X	...	X	6
51.4	Parsons Road	Single	...	X
52.3	Bridge Lane	Single	...	X
58.2	Emerson Rd	1 & 2	...	X
60.1	Construction	1 & 2	5

Note 1: Northward movements consuming more than 3 minutes between Sackett Point Road and a point 322 feet south of Stiles Lane (sides of rails painted yellow) will cause the automatic protection at Stiles Lane and Devine St to stop. Movements continuing north will reactivate the protection at a point 322 feet south of Stiles Lane. Trains must approach the crossing prepared to stop and not occupy the crossings unless the gates are in horizontal position.

Note 2: Northward trains consuming more than 30 seconds between Ward St. and Hall Ave. must approach Parker St. prepared to stop and not occupy the crossing unless the gates are in horizontal position.

Note 3: Southward trains consuming more than 45 seconds between Parker St and Ward St must approach Ward St prepared to stop and not enter crossing until the gates are in full horizontal position.

138-M1. (Cont'd)

Note 4: Southward trains, after making station stop at Meriden, must approach East Main St. and South Colony St. prepared to stop and not occupy the crossings until the gates are in the horizontal position.

Note 5: Private crossing.

Note 6: Southward trains passing “CC” sign located approximately 340 feet north of Bridge St MP 48.5 will void the “X” in Column 1.

Note 7: Northward trains that have stopped after passing MP 19.0 must approach Britannia St. MP 19.4 & North Colony St. MP 19.5 prepared to stop, and not occupy the crossings until the gates are in the full horizontal position. Trains that have reduced speed after passing MP 19.0 must not increase speed until head end clears North Colony St. MP 19.5.

Note 8: Southward trains that have stopped after passing MP 21.2 must approach North Colony St. MP 19.5 & Britannia St. MP 19.4 prepared to stop, and not occupy the crossings until the gates are in the full horizontal position. Trains that have reduced speed after passing MP 21.2 must not increase speed until head end clears Britannia St. MP 19.4.

138-M2. HIGHWAY CROSSING WARNING – OAKWOOD AVE - MP 33.6 (TRACK 2)

Due to a continuous rusty rail condition on Track 2 at Oakwood Ave - MP 33.6, crews operating over this crossing on Track 2 only (leading to or from the Parkville Industrial Trk) must comply with the requirements in item 1 of Rule 138 part “c” – Stop, make certain that crew member provides on-ground warning at the crossing, then proceed not exceeding 15 MPH until the leading end operates through the crossing.

138-M3. HIGHWAY CROSSING WARNING – PARKVILLE INDUSTRIAL TRACK

Due to a continuous rusty rail condition, crews operating over all crossings on the Parkville Industrial Track must comply with the requirements in item 1 of Rule 138 part “c” – Stop, make certain that crew member provides on-ground warning at the crossing, then proceed not exceeding 15 MPH until the leading end operates through the crossing.

900-M1. DISPATCHERS: ASSIGNED TERRITORIES

DISPATCHER	TERRITORY
Springfield Line	Mill River exclusive, to Springfield.

NEW HAVEN LINE—METRO-NORTH RAILROAD
(For Information Only)

STATIONS	MP	INT	RTC	PS	NOTES
CP 216 (Main Line-Harold to CP 216)	16.3	X	E
NEW ROCHELLE	16.6	...	↓	X	...
CP 217	16.7	X	
LARCHMONT	18.7	...		X	...
MAMARONECK	20.5	...		X	...
HARRISON	22.2	...		X	...
CP 223	23.5	X	
RYE	24.1	...		X	...
PORT CHESTER	25.7	...		X	...
STATE LINE (New York-Connecticut)	26.1
GREENWICH	28.1	...		X	...
CP 229	29.0	X	
COS COB	29.6	...		X	...
CP 230 (Movable Bridge)	30.0	X	
RIVERSIDE	30.3	...		X	...
OLD GREENWICH	31.3	...		X	...
CP 232	32.4	X	
CP 233	32.9	X		...	2
STAMFORD	33.1	...		X	...
CP 234	33.3	X		...	2
CP 235 (New Canaan Branch)	34.5	X	
NOROTON HEIGHTS	36.2	...	F	X	...
DARIEN	37.7	...	↓	X	...
ROWAYTON	39.2	...		X	...
CP 240	40.8	X	
SOUTH NORWALK	41.0	...		X	...
CP 241 (Danbury Branch) (Movable Bridge)	41.3	X	
EAST NORWALK	42.1	...		X	...
WESTPORT	44.2	...		X	...
CP 244 (Movable Bridge)	44.3	X	
GREEN'S FARMS	47.2	...		X	...
CP 248	48.6	X	
SOUTHPORT	48.9	...		X	...
FAIRFIELD	50.6	...		X	...
CP 255	55.3	X	
BRIDGEPORT	55.4	...		X	...
CP 256 (Movable Bridge)	55.8	X	
CP 257	56.8	X	
STRATFORD	59.0	...		X	...
CP 261 (Waterbury Branch) (Movable Bridge)	60.7	X	
MILFORD	63.3	...		G	X
CP 266	66.3	X	↓
CP 271	71.3	X		...	1
CP 272	71.9	X		...	1
NEW HAVEN	72.3	...		X	...
CP 273	72.4	X		...	1
STATE STREET	72.7	...		X	...
CP 274	72.7	X		...	1
DIVISION POST (Amtrak)	72.9

Note 1: Int. & CSS Rules apply between CP 271 & CP 274.

Note 2: Int. & CSS Rules apply between CP 233 & CP 234.

THIS

PAGE

INTENTIONALLY

LEFT

BLANK

MAIN LINE—HAROLD TO CP 216 (NYS)

STATIONS	MP	INT	PS	NOTES
HAROLD R-PSCC (NYT) (LIRR)	3.7	X
GATE R-PSCC	5.1	X
PELHAM BAY R-Section A TD (Mvble. Brdg.)(Market Running Trk. CRC)	15.5	X
MANOR R-Section A TD	18.2	X	...	1
DIVISION POST (MNR)	18.8
CP 216 (New Haven Line-MNR)	18.9	X

Mile Post Distances are measured from New York Penn Station.

The Direction from Harold to CP 216 is eastward.

Note 1: Equipped with movable point frogs. See SI 80-S1.

240-H1. SIGNAL RULES and CURRENT OF TRAFFIC

261: On tracks where Rule 261 is in effect, ABS Rules and CSS Rules 550 through 561 are in effect for movements in both directions.

ACES Rules: On tracks where the letter “A” follows the rule number, ACSES Rules 580–591 are in effect for movements in both directions.

Between	Tracks from South to North		Notes
	2	1	
Harold & Gate	261	261	...
West Limits Gate & CP 216	261-A	261-A	...

37-H1. PASSENGER TRAINS and FREIGHT TRAINS MAXIMUM SPEEDS and SPEED RESTRICTIONS, UNLESS OTHERWISE RESTRICTED

Locations and speeds shown in normal type are maximum authorized speeds.

Locations and speeds shown in **bold type** are speed restrictions.

Where speeds change at an interlocking and the specific point where the speed change occurs is not specified, the lower speed will apply through the entire interlocking.

PASSENGER TRAINS

Between/At	Tracks		
	No. 1	No. 2	Other
Harold & MP 10	60	60	...
First Cv west of MP 5	50	50	...
First Cv east of Gate	55	55	...
First Cv east of MP 7	50	50	...
Second Cv east of MP 8	40	40	...
MP 10 & Pelham Bay	70	70	...
Second Cv east of MP 10	60	60	...
Cv at MP 11	55	55	...
First Cv west of MP 12	...	65	...
First Cv east of MP 14	60	60	...
Cv west of Pelham Bay Br.	45	45	...

37-H1 Cont'd.			
PASSENGER TRAINS			
Between/At	Tracks		
	No. 1	No. 2	Other
Pelham Bay & CP 216	100	100	...
Cv east of Pelham Bay Br.	45	45	...
First 3 UG bridges east of MP 17	80	80	...
Cv at MP 18	70	70	...
Movements to and from MNR at CP 216	45	45	...
FREIGHT TRAINS			
Between/At	No. 1	No. 2	Other
Harold & CP 216	40	40	...
Curves west & east of Pelham Bay Int, including Int. limits	30	30	...
Movements to and from MNR at CP 216	10	10	...

37-H2. WRECK AND WIRE TRAINS

Between:	Wire Train	Boom Trailing	Boom Forward
		Miles Per Hour	
		Wreck	Wreck
Harold & CP 216	50	30	30

40-H1. ENGINE AND EQUIPMENT RESTRICTIONS

The numbers shown in the columns to the right of each listed location specify the maximum height of engines and equipment that may be operated. Engine and equipment dimension specifications are assigned in S.I. 37-S5 (page 289) for equipment authorized to operate on the NEC.

Notes shown in parentheses in the location column are defined at the end of the table.

Location	Tracks			
	2	1	5	Other
Harold Int (a)	3	3	...	3
West Limits Harold Int & MP 10 (a)	3	3	5	...
MP 10 & West Limits Pelham Bay (a)	3	3	5	...
West Limits Pelham Bay & CP 216 (a)	4	4

Note: (a) Capitoline Control Car 9637 is prohibited.

41-H1 CARS EXCEEDING 263,000 POUNDS

Providence & Worcester Railroad (P&W) trains containing cars with gross weight not exceeding 286,000 pounds may operate on all tracks between Pelham Bay and CP 216

Note: Cars operating on all other segments of the NYS Line are limited to 263,000 pounds, per SI 41-S2, page 305.

42-H1. HEIGHT RESTRICTIONS

Any equipment exceeding 14 feet 8 inches maximum height above the top of the rail is prohibited from operating in New York Penn Station, the North and East River Tunnels, and the Empire Tunnel.

47-H1. CATENARY DEAD SECTIONS

No. 1 and No. 2 Tracks between Cat. Pole 206-H and Cat. Pole 204-H.

No. 1 and No. 2 Tracks between Cat. Pole C-66 and Cat. Pole C-70.

Frequency/Voltage Change: Cat. Pole C-66 and Cat. Pole C-70 on Tracks No. 1 and No. 2 as follows:

12.5KV/60Hz in effect East of Cat. Pole C-66.

12.0KV/25Hz in effect West of Cat. Pole C-70.

On engines so equipped, manual frequency change control must be operated when passing through dead section between Cat. Pole C-66 and Cat. Pole C-70.

NOTE: In accordance with AMT-2 Instruction 3.302, Engineers of electric trains must have the throttle in the OFF position while operating through each dead section. In addition to this requirement, Engineers on ACS 64, AEM-7, HHP-8 and HST locomotives/power cars must have the Main Circuit Breaker (MCB) switch in the OPEN position while operating through each dead section and voltage change location. Electric trains that stop with a raised pantograph in a dead section or voltage change location must contact the Dispatcher for instructions.

72-H1. TRAIN INSPECTION DETECTORS

Type of Detector	MP Location	Direction of Operation	Tracks(s)	Recorder Location	Notes
HBD	18.4	West	1 & 2	Pelham Bay	...

580-H1 ACSES TERRITORY

ACSES Rules 580 through 591 and all ACSES related Special Instructions (see SI 580-S1, page 338) are in effect on Tracks 1 and 2 between the western limits of Gate Interlocking and the western limits of CP 216 for all Amtrak trains. Positive Train Stop will not be enforced eastbound at Gate and CP 216, or westbound at CP 216.

1. The controlling engine of **all Amtrak trains** operating in this territory must be equipped with on-board ACSES apparatus that is cut in and operative, except when failure occurs en route, or when hauled by an engine exempted in Special Instruction 580-S2.
2. **Non-Amtrak Trains:** Trains operated by railroads other than Amtrak are not required to be equipped with ACSES apparatus while operating in this territory.

583-H1 ACSES POSITIVE STOP: DATA RADIO RELEASE

ACSES Positive Train Stop (PTS) radio release is in service for all interlocking home signals located within or adjacent to ACSES equipped territory.

Catenary Dead Sections and Positive Train (PTS) Stop Zone: Westbound trains will experience a positive train stop within the dead sections approaching Manor and Gate Interlockings if the approximate 15MPH braking curve calculated by the onboard ACSES system is exceeded under the following conditions:

- Approaching a Stop Signal at Manor or Gate, or
- If either wayside or on-board data radio is inoperative and a Restricting cab signal is displayed

Electric engines must be operated accordingly to avoid the positive stop being enforced within the dead sections.

900-H1. DISPATCHERS ASSIGNED TERRITORIES

DISPATCHER	TERRITORY
PSCC	Harold, inclusive to Gate, inclusive.
Section A	Gate, exclusive to CP 216, exclusive.

***This
Page
Intentionally
Left
Blank***

MAIN LINE - NEW YORK TO HOFFMANS (HUD)

STATIONS	MP	INT	IS	PS	NOTES
NEW YORK (Penn Station)	0.0	...		X	...
A R-PSCC (Main Line-New York to Philadelphia) (New York Terminal District)	0.2	X	15
EMPIRE R-PSCC	1.0	X	2
CP JERVIS R-Hudson Line TD	1.5	1
INWOOD R-Hudson Line TD (Spuyten Duyvil Movable Bridge)	9.9	X	2
DIVISION POST (MNR)	10.7
CP 12 (Hudson Line) (MNR)	10.8	X
<i>METRO-NORTH TERRITORY (See Metro-North Railroad Station Page, pg. 161)</i>					
POUGHKEEPSIE (MNR)	73.6	X	...
CP 75 R- MNR Section D RTC	75.5	X
DIVISION POST (MNR)	75.8
RHINECLIFF	89.2	X	...
CP 89 R-Hudson Line TD	89.8	X	2, 3, 11
CP 94 R-Hudson Line TD	94.2	X	2,12
CP 103 R-Hudson Line TD	103.8	X	2
CP 114 R-Hudson Line TD	114.1	X	2
HUDSON (Hudson Yard) (CSX)	114.5	X	4, 10
CP 115 R-Hudson Line TD	115.4	5
CP 124 R-Hudson Line TD	123.7	X	2
CP 125 R-Hudson Line TD (Castleton Subdivision) (CSX)	125.6	X	2, 6
CP 138 R-See SI 900-U1	138.6	X	14
CP 141 R-See SI 900-U1	141.4	X	2
CP142 R-See SI 900-U1 (Post Road Branch)	141.8	X	2, 7, 15
ALBANY-RENSSELAER (Rensselaer Ind Trk)(CSX)	142.1	X	10
CP 143 R-LAB	142.2	X
CP 144 R-LAB	142.4	X
CP LAB (Movable Bridge) (LAB Industrial Trk)	143.1	X	X	...	8, 9, 10
CP 145 R-LAB (CP Rail)	143.6	X	2, 13
CP 146 R-See SI 900-U1 (W. Albany Yard)(CSX)	146.9	X	2, 10
CP 156 R-See SI 900-U1 (Carman Subdivision) (CSX)	156.5	X	2
CP 159 R-See SI 900-U1	159.6	X
SCHENECTADY	159.8	X	...
CP 160 R-See SI 900-U1 (CP Rail)	159.9	X	2
DIVISION POST (Hoffmans) (CSX)	169.7
CP 169 R-CSX NC TD	169.7	X

– Notes On Next Page –

MAIN LINE -NEW YORK TO HOFFMANS (HUD)

Mile Post New York to CP 12 are measured from New York Penn Station.
 Mile Post CP 12 to CP 169 are measured from New York Grand Central Terminal.
 The direction from A to CP 141 is North. The direction from CP 141 to CP 169 is West.
 Road radio channels in service: New York to CP 12: 060-060; (MNR) CP 12 to CP 75: 056-056; CP 75 to CP 169: 041-041.

Note 1: Northward and Southward controlled signals on No. 2 track.

Note 2: Equipped with Dual Control Switches.

Note 3: Rhinecliff Team trk is a hand-operated switch within CP-89. Permission from the Dspr is required prior to operation. Dspr must request switch reversed for unlock.

Note 4: In the application of Rule 121(b), the Dspr is responsible for providing protection for psgr trains receiving or discharging psgrs across No. 1 Trk. A proceed signal indication on Trk Nos. 1 or 2 at CP 114 or CP 115 indicates Dspr permission to enter the station. In the application of Rule 121(a), Trains on the Hudson Yard Trk and Claverack Industrial Trk approaching Hudson Station must remain clear of the station area and Broad & Front St road crossings until permission to proceed has been received from the Dspr.

Note 5: Southbound Only.

Note 6: Track 2 Only.

Note 7: The Post Road Branch connects at HUD CP 142 and extends to CSX Berkshire Subdivision CP 187.

Note 8: LAB Ind extends between MP 142.4 and MP 143.6, is located on the north side of the Main Trk, and is controlled by the LAB Operator. On the LAB Ind signal indication governs movements through CP-LAB, but CSS rules are not in effect. The Troy Ind connects with the LAB Ind north of the wye at Tracy St. (MP 0.76). The wye trks off the LAB Ind (MP 142.8) and the track between the wye and the Troy Ind are controlled by the LAB Operator.

Note 9: In service as an Interlocking Station with Road Radio Channel 041-041.

Note 10: The Troy Ind connects with the LAB Ind Trk at Tracy St. (MP 0.76) and extends north to Troy. The CSX Top End Yardmaster controls the Troy Ind Trk, Rensselaer Ind Trk, W. Albany Yard and Hudson Yard and is available on radio channel 064-064 or at telephone No. (518) 767-6277.

Note 11: Only north crossover switches (No. 21 sw) are dual control.

Note 12: Only south crossover switches (No. 12 sw) are dual control.

Note 13: Only No. 3 switch is dual control (connection to CP Rail - LAB Industrial).

Note 14: Northward and Southward controlled signals on No. 1 and No. 2 tracks.

Note 15: Equipped with slip switches. See SI 80-S1.

240-U1. SIGNAL RULES and CURRENT OF TRAFFIC

261: On tracks where Rule 261 is in effect, ABS Rules and CSS Rules 550 through 561 are in effect for movements in both directions.

Int. Indicates interlocking rules in effect.

562: On tracks where Rule 562 is in effect, Rule 261, ABS Rules, and CSS Rules 550 through 563 (except Rules 554 and 556), are in effect for movements in both directions.

Locations	Tracks from East to West				Notes
	Single	1	2	Other	
A & Empire	Int	...	1
Empire & Inwood	...	261	261
Inwood & CP 12	...	261

240-U1. (Cont'd)							
Locations	Tracks from North to South						Notes
	Single	3	1	2	4	Other	
<i>Metro North Territory (See Hudson Line - Metro North Timetable)</i>							
MP 75.8 & CP 138	261	261
CP 138 & CP 141	562	562	2
CP 141 & CP 142	...	Int	Int	Int	2, 3
CP 142 & CP 143	261	261	261	...	3
CP 143 & CP 144	261
Main Track						261	...
CP 144 & CP 156	261
CP 156 & CP 160:	Main Track					261	...
	Controlled Siding					261	
CP 160 & CP 169	261

Note 1: CSS Rules are in effect for movements in both directions.
Note 2: Interlocking rules in effect on No. 6 Track within the limits of CP 141.
Note 3: Interlocking rules in effect on No. 5 Track (Pocket Track) within CP 142.

37-U1. PASSENGER TRAINS and FREIGHT TRAINS MAXIMUM SPEEDS and SPEED RESTRICTIONS, UNLESS OTHERWISE RESTRICTED

Locations and speeds shown in normal type are maximum authorized speeds. Locations and speeds shown in **bold type** are speed restrictions.

Where speeds change at an interlocking and the specific point where the speed change occurs is not specified, the lower speed will apply through the entire interlocking.

PASSENGER TRAINS				
Between/At	Tracks			
	Single	No. 1	No. 2	Other
A Int (Exclusive) & MP 0.5	15	...
MP 0.5 & South Limit Empire Int	25	...
South Limit Empire Int & MP 2	...	35	35	...
MP 2 & Inwood	...	60	60	...
First 3 Curves North of MP 2	...	25	25	...
Curve North of MP 3	...	55	55	...
Curve at MP 5	...	55	55	...
First Curve North of MP 5	...	55	55	...
First Curve South of MP 6	...	55	55	...
Curve at MP 6.5	...	55	55	...
First 2 Curves North of MP 7	...	55	55	...
Curve South of MP 8	...	50	50	...
First 3 Curves North of MP 8	...	50	50	...
Inwood & CP 12	...	45
<i>Metro North Territory (See Hudson Line - Metro North Timetable)</i>				
MP 75.8 - 76.5	...	90	90	...
MP 76.5 - 76.6	...	80	80	...
MP 76.6 - 78.9	...	90	90	...
MP 78.9 - 85.4	...	95	95	...
MP 85.4 - 85.5	...	80	80	...

37-U1. (Cont'd)				
PASSENGER TRAINS				
Between/At	Tracks			
	Single	No. 1	No. 2	Other
MP 85.5 - 87.7	...	95	95	...
MP 87.7 - 89.8	...	80	80	...
MP 89.8 - 92.6	...	90	90	...
MP 92.6 - 93.1	...	80	80	...
MP 93.1 - 102.3	...	90	90	...
MP 102.3 - 102.6	...	80	80	...
MP 102.6 - 108.7	...	90	90	...
MP 108.7 - 109.0	...	80	80	...
MP 109.0 - 114.1	...	90	90	...
MP 114.1 - 115.0	...	50	50	...
MP 115.0 - 119.4	...	90	90	...
MP 119.4 - 119.6	...	75	75	...
MP 119.6 - 121.5	...	90	90	...
MP 121.5 - 124.3	...	85	85	...
MP 124.3 - 141.1	...	110	110	...
MP 141.1 - 141.4	...	75	75	...
MP 141.4 - 141.8	...	75	75	...
Track 3				15
MP 141.8 - 141.9	...	15	15	...
Track 3				15
MP 141.9 - 142.2	...	15	15	...
Tracks 3 & 4				15
MP142.2 - 142.4	...	15	15	...
Track 3				15
MP 142.4 - 143.1	20
MP 143.1 - 143.6	25
MP 143.6 - 145.2	40
LAB Industrial Trk				15
MP 145.2 - 146.9	80
MP 146.9 - 149.0	90
MP 149.0 - 156.3	110
MP 156.3 - 157.8	90
Controlled Siding				30
MP 157.8 - 159.6	55
Controlled Siding				30
MP 159.6 - 159.9	30
Controlled Siding				30
MP 159.7 (Over State St. Switch)				15
Connection Track to CP Rail				15
MP 159.9 - 160.3	50
MP 160.3 - 161.3	70
MP 161.3 - 164.5	100
MP 164.5 - 165.8	90
MP 165.8 - 169.7	100

37-U1. (Cont'd)				
FREIGHT TRAINS				
Between/At	Tracks			
	Single	No. 1	No. 2	Other
A Int (Exclusive) & MP 0.5	10	...
MP 0.5 & South Limit Empire Int	15	...
South Limit Empire Int & Inwood	...	30	30	...
First 3 Curves North of MP 2	...	10	10	...
<i>Metro North Territory (See Hudson Line - Metro North Timetable)</i>				
Inwood & CP 12	...	30
MP 75.8 - 114.1	...	50	50	...
MP 114.1 - 115.0	...	30	30	...
MP 115.0 - 141.1	...	50	50	...
MP 141.1 - 142.0	...	15	15	...
Track 3				15
MP 142.0 - 142.2	...	10	10	...
Tracks 3 & 4				10
MP 142.2 - 142.4	...	10
Main Track				10
MP 142.4 - 143.1	20
MP 143.1 - 145.2	25
LAB Industrial Trk				15
MP 145.2 - 156.5	50
MP 156.5 - 159.9	30
Controlled Siding				30
MP 159.7 (Over State St. Switch)				15
Connection Track to CP Rail				10
MP 159.9 - 161.3	30
MP 161.3 - 169.7	50

F-U1. RIVERSIDE PARK OVERBUILD

The Overbuild, located between MP 2.7 and MP 5.3 on the Hudson Line, consists of a structure built above ground level supporting Riverside Park and enclosing the two (2) main tracks running within, designated No. 1 and No. 2 tracks. The Overbuild is approximately 2.5 miles long with west 72nd Street at the south end and west 123rd Street at the north end. The entire length falls under the jurisdiction and authority of the Hudson Line Dispatcher, 40 Office, New York.

The Overbuild has been constructed with fixed steel grates within the ceiling at regular intervals for ventilation, and locked gates in the west wall at various locations to provide emergency access by Emergency personnel only, they are **NOT** intended as exits.

The Overbuild is equipped with coaxial antennas, providing for radio communications between trains and the Hudson Line Dispatcher only.

37-U2. WRECK AND WIRE TRAINS SPEEDS

Between:	Wire Train	Wreck Boom Trailing	Wreck Boom Forward
	Miles Per Hour		
A & North End Tunnel	10	10	10
North End Tunnel & MP 2	15	15	15
MP 2 & Inwood Int	30	30	20
Inwood & CP 12	30	20	20
Poughkeepsie & Hoffmans	30	20	20

Note: Where speed of freight trains is slower than speeds shown in this instruction, the freight train speed must not be exceeded.

37-U3. MAXIMUM SPEEDS-OTHER TRACKS

Location	Between/At	Restricted Speed Not Exceeding
Empire	Wye Track	5
MP 142.9	North leg of the Wye	5
Unless Otherwise Specified: All Yard Trks, Industrial Trks and Public Delivery Trks connected with Amtrak Main or Running Trks		10

37-U4. MINERAL FREIGHT TRAINS: SPECIAL MAXIMUM SPEEDS

The 30 MPH speed restriction on Mineral Freight Trains found in SI 37-S4, page 287 only applies between CP 145 and CP 146 on the Main Line - New York to Hoffmans (HUD).

40-U1. ENGINE AND EQUIPMENT RESTRICTIONS

The numbers shown in the columns to the right of each listed location specify the maximum height of the engines and equipment that may be operated. Engine and equipment dimension specifications are assigned in S.I. 37-S5 (page 289) for equipment authorized to operate on the NEC.

Notes shown in parentheses in the location column are defined at the end of the table.

Between	Tracks		
	1	2	Other
A & Empire (a)(b)	1	1	1
Empire & CP 12 (a)(c)	4	4	...
Poughkeepsie & CP 156 (d)	6	6	...
CP 156 & Hoffmans	5	5	5

Notes:

- (a) Capitoliner Control Car 9637 is prohibited from operating on the Hudson Line.
- (b) Engines of dimension #2 may operate when verbally authorized by the Dspr at PSCC.
- (c) Operation on the Wye at Empire is restricted to single units only.
- (d) Cars exceeding 286,000 lbs are prohibited.

42-U1. HEIGHT RESTRICTIONS

Any equipment exceeding 14 feet 8 inches maximum height above the top of the rail is prohibited from operating in New York Penn Station, the North and East River Tunnels, and the Empire Tunnel.

43-U1. CLOSE CLEARANCE

MP	Location	Remark(s)
75	Metro North Stations	High Level Platforms
142.1	1, 2, & Main Tracks	Passenger Platforms

47-U1. TRACKS EQUIPPED FOR DC ELECTRICAL OPERATION

No. 2 track between A and a point 235 feet north of MP 1.

No. 1 track between beginning of track at Empire and a point 235 feet north of MP 1.

47-U2. DC OPERATION RESTRICTED NORTH OF MP 5

Trains must not operate north of MP 5 with third rail shoes in lowered position, unless otherwise instructed.

72-U1. TRAIN INSPECTION DETECTORS

Type of Detector	MP Location	Direction of Operation	Tracks(s)	Notes
RA HBD-DED	83.7	North & South	1 & 2	1
RA HBD-DED	99.2	North & South	1 & 2	1
RA DED	164	East & West	Single	1

Note 1: SI 72-S1 (page 313) applies.

104-U1. SWITCHES EQUIPPED WITH ELECTRIC LOCKS

The following hand-operated switches are equipped with an electric lock; permission to occupy Main Track, Interlocking or Controlled Siding must be obtained from the Dispatcher before lock is removed from keeper.

Location	Switch	Notes
MP 1.2	Switch in No. 2 trk. leading to Wye Lead trk.	1
MP 1.4	Switch in No. 2 trk. leading to Tail trk.	1
MP 83.3	Switch in No. 2 trk leading to Staatsburg Team trk	...
MP 89.8	Switch in No. 1 trk leading to Rhinecliff Team Track	...
MP 112.9	Switch in No. 1 trk leading to Hudson Yard South	...
MP 113.5	Switch in No. 2 trk leading to River Track	...
MP 113.9	Switch in No. 1 trk leading to Hudson Yard South (Short-crossover)	...
MP 114.5	Switch in No. 1 trk leading to Hudson Yard North	...
MP 123.8	Switch in No. 2 trk leading to Stuyvesant Team Track	...
MP 141.8	Switch in No. 2 trk leading to Rensselaer Ind / Freight Bypass	...
MP 159.7	Switch in Controlled Siding trk leading to State St. Yard	...

Note 1: To enter side track from Main Track, train must occupy track circuit which extends 50 feet from point of switch, before switch can be opened.

132-U1. TRACKS AND SWITCHES OUT OF SERVICE

The tracks and switches listed below are out of service for train movements, except when such movements are personally supervised by an MW Foreman or MW Supervisor, or when movement consists entirely of track cars.

If a remotely controlled switch provides access to an affected track, the Operator or Dispatcher must apply blocking device protection to prevent the accidental routing of trains to that track. If a hand operated switch provides access to an affected track, the last Engineering Department employee to use the switch must spike the switch to prevent its accidental use.

MP Location	Track/Switch
83.3	Staatsburg Team Trk
89.8	Rhinecliff Team Trk
94.6	Barrytown Team Trk
99.2	Tivoli Team Trk
113.9	Hudson Yard South Short-crossover
123.8	Stuyvesant Team Trk
141.8	Freight By-Pass South

138-U1. PUBLIC CROSSINGS AT GRADE

Column 1: Apparatus provided to automatically interrupt operation of highway crossing protection, including motion sensing detectors and/or predictors. Rule 138(g)(3 & 4) applies.

Column 2: Apparatus provided to interrupt operation of crossing protection manually by manipulation of a lever, plug or push button generally located on the signal control case close to the crossing. Rule 138(h) applies.

Column 3: Circuitry will automatically interrupt crossing protection when switches, located within the activation circuit of the crossing, are reversed. After protection has been interrupted, trains must not occupy the crossing until the protection has been operating for at least 20 seconds, or if equipped with gates, they are in the horizontal position. Rule 138(g)(6) applies. (Also, see S.I.'s 138-S1 & 138-S2, pgs 325 & 325)

MP	CROSSING	1	2	3	Notes
76.0	River Point Rd	...	X	...	1
81.5	Poughkeepsie Yacht Club	...	X	...	1
83.7	River Rd
99.0	Tivoli Rd	...	X	...	1
103.5	Cheviot Rd
106.1	Anchorage Rd
114.3	Broad St.	X	3
122.0	Ferry Rd
122.25	Ice House Rd	X
124.2	Riverview Park Rd
134.1	Castleton Boat Club
134.4	Scott Ave
135.0	Hamilton Way
137.2	Staats Island Rd
140.0	Tellers Crossing	X
149.8	Lincoln Ave	X
153.5	Morris Rd	X
154.3	Cordell's Rd	X
164.6	Wyatts Rd	...	X	...	2
165.2	Rector Rd
166.5	Stone Arabia Rd	...	X	...	2

Note 1: De-activate Only. 2 Tracks - 2 Boxes

Note 2: De-activate/Activate

Note 3: Track 1 switch MP 114.5 - Switch Reverse- Gate recover on Track 1 only.

294-U1. SLIDE FENCE PROTECTION

Slide detector apparatus are in service on the HUD Main Line at the mileposts listed below. They are connected with the automatic block signal system to restrict train movement when activated.

Trains operating through these locations that receive a cab signal aspect change to Restricting must operate through the slide detector limits prepared to stop short of an obstruction on the track.

Trains with inoperative cab signals and trains governed by DCS Rules (Rule 406 DCS substitution for ABS) must approach the slide detector prepared to stop short of an obstruction, and must not exceed Restricted Speed through the limits of the slide detector.

These restrictions apply to the head end only.

Slide Detector Fence Mileposts				
105.29-105.41	106.01-106.08	107.44-107.55	128.13-128.22	129.03-129.15
105.68-105.82	106.96-107.03	119.43-119.56	128.91-128.99	129.89-130.04

562-U1. “NO FIXED ABS” SIGNS AT ENTRANCE TO RULE 562 TERRITORY”

A white sign with a RED CIRCLE AND A RED DIAGONAL LINE across black letters “FIXED ABS” is attached to the back side of the westbound cantilever signal mast for Tracks 1 & 2 at CP 141, and to the northbound home signals for Tracks 1 & 2 at CP 138, to remind employees that they are entering Rule 562 territory, where cab signals are used WITHOUT fixed automatic block signals.



706-U1. PORTABLE RADIO TRANSMISSIONS WITHIN THE EMPIRE TUNNELS

“NYP Road Rptr” channel is in service for portable radios within the North River, East River and Empire Tunnels. Lower powered portable radio transmissions made on “NYP Road Rptr” within the tunnels are picked up by a repeater and retransmitted on Road Channel 060 at high enough power to be received by portable and/or engine radios also located within the tunnels. While the “NYP Road Rptr” channel transmits on the repeater frequency, it receives on Road Channel 060.

Note: No adjustment is necessary for engine radios to communicate with portable radios while within the tunnels.

The Dispatcher at PSCC receives all transmissions made within the tunnels on Road Channel 060 or “NYP Road Rptr”.

900-U1. DISPATCHERS: ASSIGNED TERRITORIES

Monday through Friday 7:00 AM – 11:00 PM	
DISPATCHER	TERRITORY
PSCC	A, inclusive, to Empire, inclusive
Hudson Line	Empire, exclusive, to CP 12, exclusive. MP 75.8 to CP 138 exclusive.
Hudson North	CP 138 inclusive to CP169, exclusive
Monday to Friday 11:00 PM to 7:00 AM and Weekends	
DISPATCHER	TERRITORY
PSCC	A, inclusive, to Empire, inclusive
Hudson Line	Empire, exclusive, to CP 12, exclusive. MP 75.8 to CP 169, exclusive

940 -U1 / 950-U1. TRAIN AND ENGINE SERVICE EMPLOYEES

Train and Engine Service employees signing up in Albany must report to and receive instructions from the Albany Yard Master (formally know as the Albany Station Master).

POST ROAD BRANCH (PRB)

STATIONS		MP	INT	PS	NOTES
CP 187	Division Post (CSX) R-CSX NB TD (CSX Berkshire Sub)	187.5	X
CP 142	R-LAB (Hudson Line)	199.5	X	...	1, 2
The Post Rd Branch extends westward from CSX Berkshire Subdivision CP 187 to Amtrak HUD CP 142. Mileposts are numbered 187.5 to 199.5.					
Note 1: The LAB Operator can be reached on Road Radio Channel 041-041.					
Note 2: Equipped with slip switches. (See SI 80-S1)					

240-PR1. SIGNAL RULES

Locations	Single Track	Notes
CP 187 (MP 187.5) & CP 142 (MP 199.5)	261	...

37-PR1. PASSENGER TRAINS and FREIGHT TRAINS MAXIMUM SPEEDS and SPEED RESTRICTIONS, UNLESS OTHERWISE RESTRICTED

Locations and speeds shown in normal type are maximum authorized speeds. Locations and speeds shown in **bold type** are speed restrictions.

Where speeds change at an interlocking and the specific point where the speed change occurs is not specified, the lower speed will apply through the entire interlocking.

Location	Between/At	Speed	
		Psg	Fr
Post Road Single Track	MP 187.5 and MP 196.5	79	50
	MP 196.5 and MP 196.7	65	50
	MP 196.7 and MP 199.0	79	50
	MP 199.0 and MP 199.5	15	10

40-PR1. ENGINE AND EQUIPMENT RESTRICTIONS

The numbers shown in the columns to the right of each listed location specify the maximum height of the engines and equipment that may be operated. Engine and equipment dimension specifications are assigned in S.I. 37-S5 (page 289) for equipment authorized to operate on the NEC.

Notes shown in parentheses in the location column are defined at the end of the table.

Location	Single Track	
	Dim Equip	Notes
Post Road Branch	6	1, 2
Note 1: Merchandise Freight: cars exceeding 263,000 lbs prohibited.		
Note 2: Coal, Ore, & Grain cars exceeding 270, 000 lbs prohibited.		

138-PR1. HIGHWAY RAIL GRADE CROSSINGS AT GRADE EQUIPPED WITH AUTOMATIC WARNING DEVICES

Column 1: Apparatus provided to automatically interrupt operation of highway crossing protection, including motion sensing detectors and/or predictors. Rule 138(g)(3) applies.

Column 2: Apparatus provided to interrupt operation of crossing protection manually by manipulation of a lever, plug or push button generally located on the signal control case close to the crossing.

Column 3: Circuitry will automatically interrupt crossing protection when switches, located within the activation circuit of the crossing, are reversed. After protection has been interrupted, trains must not occupy the crossing until the protection has been operating for at least 20 seconds, or if equipped with gates, they are in the horizontal position.

(Also, see S.I.'s 138-S1 & 138-S2, pgs 325 & 325)

MP	CROSSING	1	2	3	Notes
188.5	Duck Pond Rd	...	X	...	1
189.4	Eleanor Dr	...	X	...	1
191.1	Maple Hill Rd	...	X	...	1
195.4	Hays Rd	...	X	...	1

Note 1: De-activate/Activate.

900-PR1. DISPATCHERS: ASSIGNED TERRITORIES

DISPATCHER	TERRITORY
Hudson Line	CP 142, inclusive to CP 187 (CSX), exclusive.

NIAGARA WHIRLPOOL BRIDGE (NGB)

STATIONS	MP	INT	PS	Notes
Division Post (CSX CP 28) (Niagara Whirlpool Bridge) (CSX) (Niagara Branch Sub)	28.2	1
Division Post (CN MP 0.47) (Niagara Whirlpool Bridge) (CN) (Grimsby Sub)	28.57	1

The direction from MP 28.2 to MP 28.57 is North.

Note 1: The Niagara Whirlpool Bridge Trk between MP 28.2 and MP 28.57 is governed by NORAC Rule 98 – “Movement on a track not governed by ABS, DCS or interlocking rules must be made at Restricted Speed.”

A-NG1. REQUIRED BOOKS

Crews operating on the Niagara Whirlpool Bridge are not required to carry the NORAC Operating Rules.

37-NG1. MAXIMUM SPEED

Location	Between/At	Restricted Speed Not Exceeding	
		Psg	Frt
Niagara Whirlpool Bridge	MP 28.2 & MP 28.57	10	10

40-NG1. ENGINE AND EQUIPMENT RESTRICTIONS

The numbers shown in the columns to the right of each listed location specify the maximum height of the engines and equipment that may be operated. Engine and equipment dimension specifications are assigned in S.I. 37-S5 (page 289) for equipment authorized to operate on the NEC.

Notes shown in parentheses in the location column are defined at the end of the table.

Location	Single Track	
	Dim Equip	Notes
Niagara Whirlpool Bridge	6	...

900-NG1. DISPATCHERS: ASSIGNED TERRITORIES

DISPATCHER	TERRITORY
Hudson Line	MP 28.2, exclusive to MP 28.57, exclusive

HUDSON LINE—METRO-NORTH RAILROAD
(For Information Only)

STATIONS	MP	INT	RTC	PS	NOTES	
CP 12 (Amtrak Hudson Line)	11.8	X	C ↓	
RIVERDALE	13.0	...		X	...	
LUDLOW	14.4	...		X	...	
YONKERS	15.2	...		X	...	
GLENWOOD	16.3	...		X	..	
GREYSTONE	17.9	...		X	...	
CP 19	18.5	X		
HASTINGS-ON-HUDSON	19.5	...		X	...	
DOBBS FERRY	20.7	...		X	...	
ARDSLEY-ON-HUDSON	21.8	...		X	...	
IRVINGTON	22.7	...		X	...	
CP 25	24.7	X		
TARRYTOWN	25.3	...		X	...	
CP 26	26.4	X		
PHILIPSE MANOR	26.5	...		X	...	
SCARBOROUGH	29.5	...		X	...	
OSSINING	30.9	...		X	...	
CP 33	32.9	...		D ↓
CROTON-HARMON	33.3	...			X	...
Harmon Yard	33.3
CP 34	33.4	X	
CP 35	34.2	X	
CP 36	36.4	X	...		1	
CORTLANDT	38.4	...	X		...	
CP 39	39.7	X	
PEEKSKILL	41.3	...	X		...	
CP 46	46.0	X	
MANITOU	46.1	...	X		...	
<i>Hot Box/ Dragging Equipment/ Third Rail Detector</i>	48.3	
GARRISON	49.9	...	X		...	
COLD SPRING	52.4	...	X		...	
CP 53	53.0	X	
BREAKNECK RIDGE	55.0	...	X		...	
CP 58 (Beacon Line)	58.6	X	
BEACON	59.0	...	X	...		
CP 61	61.4	X		
NEW HAMBURG	65.1	...	X	...		
CP 72	72.5	X		
POUGHKEEPSIE	73.6	...	X	...		
CP 75	75.5	X		
DIVISION POST (Amtrak)	75.8		

CSS Rules apply between CP 12 & CP Division Post MP 75.8.

Note 1: Int in service on No. 4 trk and yard trk 6 only.

***This
Page
Intentionally
Left
Blank***

NEW YORK TERMINAL DISTRICT (NYT)

STATIONS	MP	INT	PS	NOTES
A R-PSCC (Hudson Line) (Main Line-New York to Philadelphia)	0.2	X	...	6
KN R-PSCC (Penn. Station)	0.1	X	...	6
NEW YORK R-PSCC	0.0	...	X	...
C R-PSCC	0.1	X	...	6
JO R-PSCC	0.1	X	...	6
F R-PSCC (Sunnyside Yard) (North Runner Trk) (Sub 1, 2 & 3 Running Trks.) (Loops: "A", 1 & 2 Running Trks.)	3.0	X	...	1, 2, 4, 5
HAROLD R-PSCC (Main Line-Harold to CP 216) (LIRR) (Connecting Running Track)	3.7	X	...	3

Mile Post Distances are measured from New York Penn Station.
 The Direction from New York to Harold is eastward.
 The direction from New York to A is westward.
 Q & Loop Ints, and R Switching Center are located in Sunnyside Yard. Loop Int is remotely controlled by R, and is equipped with dual control switches.
Note 1: Sub 1, 2 & 3 Running Tracks between Q & F, controlled by Q.
Note 2: Loop "A", 1 & 2 Running Tracks between F & R, controlled by R.
Note 3: Connecting Running Track between Q & End of Track, controlled by Q.
Note 4: Q to R – North Runner Trk, Hump Trk & Eastward Engine Trk controlled by R.
Note 5: Equipped with movable point frogs. See SI 80-S1.
Note 6: Equipped with slip switches. See SI 80-S1.

240-T1. SIGNAL RULES and CURRENT OF TRAFFIC

On tracks where Rule 261 is in effect, ABS Rules and CSS Rules 550 through 561 are in effect for movements in both directions.

Between	Tracks				Notes
	4	3	2	1	
A & JO	Interlocking Rules in effect on Tracks 15 through 5				...
A & C	Interlocking Rules in effect on Tracks 18 through 16				...
KN & C	Interlocking Rules in effect on Tracks 21 through 19				...
JO/C & Harold	261	261	261	261	...
F & Harold	Interlocking Rules in effect on Line 2 Connection				1

Within Penn. Station, New York, station tracks 5 through 21 are designated Main tracks.

Note 1: CSS Rules in effect for movement in both directions.

37-T1. PASSENGER TRAINS and FREIGHT TRAINS MAXIMUM SPEEDS and SPEED RESTRICTIONS, UNLESS OTHERWISE RESTRICTED

Locations and speeds shown in normal type are maximum authorized speeds. Locations and speeds shown in **bold type** are speed restrictions.
 Where speeds change at an interlocking and the specific point where the speed change occurs is not specified, the lower speed will apply through the entire interlocking.

PASSENGER TRAINS				
Between/At	Tracks			
	No. 1	No. 2	No. 3	No. 4
West Limits A Int. & East Limits JO & C Ints.	All tracks 15 MPH			
★ Through East River Tunnels	60	60	60	60
East River Tunnels & Harold	60	60	60	60
F Int. Line 2 Connection	45 MPH			
Harold Int.:				
Diverting movements to & from NYS No. 1 trk	45 MPH			
Long Island City Westward Psgr Trk.	30 MPH			
Long Island Frt Trk.	60 MPH			
Notes:				
★ Amtrak Capitoliner Control Cars, series 9632 through 9651 and conference car 9800 are restricted to 50 MPH through the East River Tunnels, JO & C to F.				
★ In addition, Amtrak car 9800 must not exceed 30 MPH between signal locations listed in 37-T6, pg 167.				
FREIGHT TRAINS				
Between/At	No. 1	No. 2	No. 3	No. 4
West Limits A Int. & East Limits JO & C Ints.	All Tracks 8 MPH			
Through East River Tunnels:	20	20	20	20
Except: Between Signal 3E04 and 6th Ave. Portals	15	...
East River Tunnels & Harold	20	20	20	20
F Int.: Line 2 Connection	30 MPH			
Harold Int.:				
Diverting movements to & from NYS No. 1 trk	20 MPH			
Long Island City Westward Psgr trk	30 MPH			
Long Island Frt trk	25 MPH			

C-T1. LONG ISLAND RAILROAD EMPLOYEES

Timetable, Book of Rules and General Notices of the Long Island Railroad will apply and be the authority for movement of Long Island Railroad trains and track cars between Harold and A, under the direction of Terminal Superintendent. Amtrak Movement Permit Form D will be used in lieu of Long Island Railroad Form L. Differences between Amtrak and Long Island Railroad operating rules and procedures will be covered in Long Island Railroad Special Instructions and General Notices and reviewed in periodic examination classes.

C-T2. PHYSICAL CHARACTERISTICS QUALIFICATION - ASSISTANT CONDUCTORS AND CONDUCTORS

Amtrak New York Crew Base Zone 1 and Zone 2 Assistant Conductors must be qualified on the physical characteristics of New York Pennsylvania Station and Sunnyside Yard. Conductors and Assistant Conductors absent from work train, yard and/or relay service in the New York Terminal District for 6 months or longer must contact a Terminal Trainmaster or an Operating Practices Department representative before starting such an assignment.

16-T1. BLUE SIGNAL PROTECTION: NEW YORK PENN STATION TRACKS 5 THROUGH 21

The following blue signal protection procedures apply on New York Penn Station Tracks 5 through 21, which are designated as Main Tracks in SI 240-T1 (see page 163).

NOTE: The provisions of Rule 16 pertaining to “Other Than Main Tracks” apply to New York Penn Station Tracks 1 through 4, and tracks in Yards A, C, D and E.

Responsibility of All Mechanical Employees

Mechanical employees must not perform any work that requires blue signal protection until assured by the Mechanical Foreman or qualified craft employee in charge that blue signal protection has been provided.

Responsibilities of Mechanical Foreman or Qualified Craft Employee

The Mechanical Foreman or qualified craft employee in charge must take the following actions before authorizing or performing any work that requires blue signal protection:

1. Ensure that other equipment on the track to be protected is at least 20 feet from the equipment to be worked, or as far from the equipment as possible.
2. Contact the PSCC Dispatcher at telephone number 6006 to obtain “**Supplemental Blue Signal Protection**” on the required track.

NOTE: This protection prevents the Dispatcher from routing trains **to** the affected track; it does not prevent the Dispatcher from routing trains **off** the affected track. The protection is considered “supplemental” because the law that governs blue signal protection on main tracks requires only actions 3 and 4 below.

3. Display a Blue Signal at each end of the equipment to be worked.
4. Attach a Blue Signal to the controlling engine(s) at a location where it will be clearly visible to an employee at the controls of that engine.

After all work has been completed, the individual who requested the “Supplemental Blue Signal Protection” will check to see that all employees are in the clear, then call the Dispatcher to give up the protection.

Responsibilities of PSCC Train Dispatcher

The PSCC Dispatcher must take the following actions when granting “Supplemental Blue Signal Protection”:

1. Before granting “Supplemental Blue Signal Protection,” the Dispatcher must apply blocking devices to prevent the display of any signal leading to the affected track.
2. Once “Supplemental Blue Signal Protection” is granted, the Dispatcher must not remove the blocking devices or authorize any equipment to enter the track until informed by the employee in charge of the workmen that the work has been completed.
3. The Dispatcher must immediately make a written record on the prescribed form of the application and removal of the blocking device protection. This record must be retained for 15 days following the date of removal.

19-T1. ENGINE WHISTLE OR HORN: PENN STATION, A, JO, C, AND KN INTERLOCKINGS

Except when approaching Roadway Workers or in an emergency, trains must **not** sound their engine whistle or horn while within A, JO, C and KN interlockings or within the roofed or enclosed areas of Penn Station. This restriction is intended to prevent hearing loss injuries to passengers as well as employees working in the station.

22-T1. ENGINE HEADLIGHT: PENN STATION

Trains standing in New York Penn Station must extinguish their headlights until ready to depart. Prior to initiating movement the headlight must be displayed according to NORAC Rule 22.

34-T1. SUNNYSIDE - 480 VOLT STANDBY

To assist crews in spotting equipment for 480 volt standby, yellow stripes are painted adjacent to tracks 1 through 11, west of the COBRA crossing. When equipment is left standing on these tracks, the rear car must be spotted next to the yellow stripe.

36-T1. PENN STATION: SPOTTING 9 CAR PUSH-PULL SET

Trains arriving at PSNY routed to Track 2 with a 9 car push-pull set will arrange to spot their equipment with the engineers cab window adjacent to the 9PP car marker sign located at the east end of the platform.

37-T2. ACSES TRAIN TYPE SELECTOR SWITCH

Different Train Type "B" definitions are in effect on the NYP and NHB lines. Engineers taking charge of Regional service passenger trains in New York must ensure that the train type selector switch is in the proper position for the Train Type "B" definition in effect on the line they will traverse.

37-T3. SPEEDOMETER CHECKING: MEASURED MILES

White marker posts bearing the letters MM (measured mile) are in service for eastward movements at the following locations:

No. 1 (Line 1) track at Signal 1E14 and a point 2420 feet east of Long Island City shaft.

No. 2 (Line 2) track 75 feet east of Signal 2E14 and 2550 feet east of the Long Island City shaft.

No. 3 (Line 3) track 437 feet east of Signal 3E14 and 3000 feet east of the Long Island City shaft.

No. 4 (Line 4) track at Signal 4E14 and a point 2700 feet east of Long Island City shaft.

37-T4. MAXIMUM SPEEDS-RUNNING TRACKS

Track	Between	And	Restricted Speed not exceeding
North Runner	Q	R	15 MPH
Sub Tracks 1 & 2	Q	Reverse curves at jump over of Line 2 & Line 4 trks	8 MPH
Sub Tracks 1 & 2	Reverse curves at jump over of Line 2 & Line 4 trks	F	15 MPH
Sub Trk 3	Q	F	8 MPH
Connecting	Q	End of Track	5 MPH
Loop Nos. 1 & 2	F	First curve east of Loop	15 MPH ★
Loop A	Loop	First curve east of Loop	15 MPH
Loop A, 1 & 2	First curve east of Loop	R	5 MPH

★ - Drafts containing passenger cars on Loops Nos. 1 and 2 must not exceed 3 MPH while moving through car washing machines when cars are being washed.

37-T5. MAXIMUM SPEEDS-OTHER TRACKS

Location	Tracks	Restricted Speed not exceeding
Sunnyside Yard	Eastward and Westward Engine Tracks	5 MPH
Sunnyside Yard	All tracks between R Switching Center and the western limits of Q Int, except the North Runner	5 MPH

37-T6. SPEED RESTRICTIONS: AMTRAK CAR 9800: JO & C TO F

Amtrak car 9800 must not exceed 30 MPH when operating within the East River Tunnels between the signal locations listed below.

Track	Eastward	Westward
No. 1 (Line 1)	1E08-1E14	1E15-1E09
No. 2 (Line 2)	2E08-2E14	2E17-2E07
No. 3 (Line 3)	3E08-3E14	3E17-3E07
No. 4 (Line 4)	4E08-4E14	4E15-4E07

40-T1. ENGINE AND EQUIPMENT RESTRICTIONS

The numbers shown in the columns to the right of each listed location specify the maximum height of the engines and equipment that may be operated. Engine and equipment dimension specifications are assigned in S.I. 37-S5 (page 289) for equipment authorized to operate on the NEC.

Notes shown in parentheses in the location column are defined at the end of the table.

Location	Tracks				
	4	3	2	1	Other
A Int. & JO—C: All Station tracks (a)(b)	1	1	1	1	1
JO—C & F (a)(b)	1	1	1	1	...
F & Harold (a)	3	3	3	3	...
Sunnyside Yard, all tracks	3	3	3	3	3
High Speed Rail S&I Building, all tracks	1

Notes:

(a) Capitoline Control Car 9637 is prohibited from operating between A and Harold.

(b) Engines of dimension #2 may operate when verbally authorized by the Dispatcher at PSCC.

41-T1. CWR EQUIPMENT-A and HAROLD

Freight trains containing two or more Continuous Welded Rail (CWR) cars coupled to each other must operate No. 11 trk. through Penn Station; No. 1 trk between JO & Harold or No. 12 trk through Penn Station; No. 2 trk between JO & Harold with no diverging movements at A, JO or F interlockings; and are prohibited on Connecting trk. between Harold & Q interlockings. This restriction applies to CWR cars of foreign railroads & includes Amtrak equipment in car series 15250-15252, and 15260-15316.

42-T1. HEIGHT RESTRICTIONS

Any equipment exceeding 14 feet 8 inches maximum height above the top of the rail is prohibited from operating in New York Penn Station, the North and East River Tunnels, and the Empire Tunnel.

43-T1. CLOSE CLEARANCE: JO TO A

Close clearance exists at the east end of No. 14 track adjacent to stairway, where pedestrian barricade is erected along platform. Crews must exercise caution and must not discharge passengers in this area.

43-T2. CLOSE CLEARANCE: SUNNYSIDE YARD CAR SHOP AND LOCOMOTIVE SERVICING TRACKS

Within the Sunnyside Locomotive & Coach Repair Shop, the ground along the north and south sides of Tracks 38 (Wheel 4) and 39 (Wheel 5) is marked in red due to close clearance. Equipment or other obstructions adjacent to these tracks and within the red area will foul these tracks. Equipment operating on these tracks encountering equipment or obstructions within the red area must stop immediately and may not continue movement until the equipment or obstruction is clear.

47-T1. TRACKS EQUIPPED FOR DC ELECTRICAL OPERATION:

All Main Tracks: between Harold and C-JO.

Running Tracks: Sub tracks 1, 2 and 3 to a point 1000 feet east of connection with No. 4 track (Line 4) and No. 2 track (Line 2) at F. Loop tracks No. 1 & 2 to a point 1000 feet east of connection with No. 1 track (Line 1) and No. 3 track (Line 3) at F.

Other Tracks: Lead tracks 3 and 5 at Q, No. 1 Enginehouse track, Hump track, Lead track No. 6 at R connection with Hump track, Eastward Engine track between Q and Sunnyside Enginehouse.

New York, Pennsylvania Station: A Yard—Track 5A, D Yard —Track 6, Station tracks 5 through 21 inclusive, No. 1x, and No. 3x through 6x tracks inclusive. Tracks 8C, 9C & 10C between KN and Yard C.

90-T1. DEADHEADING EMPLOYEES – Q INTERLOCKING

To assist employees deadheading from Sunnyside Yard to New York, a high level platform approximately 12 feet long is in service within Q Interlocking at the west end of the Eastward Engine Track (Inbound) beneath Queens Boulevard overhead bridge. Westward New Jersey Transit trains are authorized to make a **brief** stop at this location to pick up employees when they are seen on or about the platform.

98-T1. R SWITCHING CENTER

Movements through R Switching Center are governed by indications of fixed signals controlled by the Operator at R.

R Switching Center is not an Interlocking, however Interlocking Rules 600 through 616 and Special Instruction 601-S1 govern operations at R Switching Center.

98-T2. SUNNYSIDE YARD - HIGH SPEED RAIL SERVICE AND INSPECTION BUILDING

High Speed Rail S & I Building has No. 1 and No. 2 Tracks extending through the building with power-operated derrails, controlled by the mechanical department, located on both ends of each track. Fixed overhead flashing blue signals mounted on the building exterior, when illuminated indicate that the restrictions of Rule 16 "Blue Signal Protection of Workers" apply.

98-T3. CONTROL OF YARD TRACKS

1. Sunnyside Yard - Car Shop and Locomotive Servicing Tracks

The following Sunnyside Maintenance Facility tracks are designated Car Shop and Locomotive Repair Tracks. Authority of the employee named must be obtained before any movement is made. The Yardmaster and High Speed Rail Foreman may be contacted on channel 036-036. The Mechanical Foreman may be contacted on channel 043-043.

TRACKS	CONTROLLED BY
Tracks 37 (Wheel 3), 38 (Wheel 4), & 39 (Wheel 5) of the Locomotive & Coach Repair Shop between 50 feet west of derail on west end and 50 feet east of derail on east end.	Mechanical Foreman, Sunnyside Yard
Engine House Track & Engine Ready Track of the Locomotive & Coach Repair Shop between the "Entering Engine House Territory" signs posted outside the building limits.	Mechanical Foreman, Sunnyside Yard
S&I Tracks 1 & 2 of the High Speed Rail Inspection Building between the "Stop-Do not Enter Without Supervisor's Permission" signs posted outside the building limits.	High Speed Rail Foreman, Sunnyside Yard

2. Yardmaster

The Yardmaster is in charge of movements on all other tracks in Sunnyside Yard.

102-T1. PENNSYLVANIA STATION—NEW YORK: FLASHING RED LAMPS.

When mail, baggage or express is being loaded or unloaded on cars not attended by a crew in Penn Station, a red flashing lamp will be placed on both ends of the equipment. When red flashing lamps are displayed, crews must not couple to or move the cars until they have contacted the Baggage Foreman and he has removed the lamps.

104-T1. NORMAL POSITION OF SWITCHES AND CROSSOVERS AT SPECIFIED LOCATIONS

Switch location	Connecting	With	Normal Position is for Movement	Notes
Q Int.	1 Lead	Wheel Shop	To Engine House Territory	1
Q Int.	1 Lead	West Lead of Engine House	To Engine House Territory	1
West of R	Wheel Shop Lead	East Lead of Engine House	To Engine House Territory	...
Hump Track Sunnyside Yard	Hump Track	Eastward Engine Trk	To Eastward Engine Track	...

Note 1: Employees operating on or off the west end of Tracks 36, 37, 38 & 39 upon completion of their movement **MUST** line switches for movement to Engine House territory.

104-T2. FOULING POINT - SUNNYSIDE YARD SWITCHES

The fouling point of switches within Sunnyside Yard is indicated by a red stripe painted on the crossties and/or web of both rails. Equipment placed on any track in Sunnyside Yard must be positioned clear of the fouling point. When conditions do not permit equipment to clear the fouling point, a crew member must immediately notify the Yardmaster and advise which track(s) is fouled.

104-T3. SUNNYSIDE YARD - MOVEMENT RESTRICTIONS

At most locations in Sunnyside Yard, movement from 2 or more yard tracks into Q Interlocking and R Switching Center is governed by a common signal. To avoid the possibility of conflicting movements, trains operating from Sunnyside Yard to Q or R must obtain verbal permission from the Operator before accepting the signal or fouling the switches prior to the signal.

104-T4. SUNNYSIDE YARD - MOVEMENTS NORTH RUNNER TO MW STORAGE TRACK

A hand operated facing point turnout is in service 625 feet west of R Interlocking home signal for westbound movements from the North Runner to the east end of the MW Storage Track. Dwarf signals are in service on the North Runner east and west of the switch.

When the switch is lined in normal position for movement on the North Runner the signals will display Restricting and a pipe connected derail remains applied on the Storage Track.

When the switch is lined for movement to the MW Storage Track the signals will display Stop Signal and the derail will be in the non-derailing position.

Movement from the North Runner to the MW Storage Track must operate past the Restricting signal and stop prior to reaching the switch points before operating the switch.

Movement from the MW Storage Track to the North Runner must receive permission from the Operator at R before the switch may be operated.

Note: In the application of Rule 241, when Stop Signals are displayed at this location, authority to pass the signal must come from the Operator at R after the proper position of the switch has been verified and reported to the Operator.

108-T1. ENGINES UNATTENDED, PENNSYLVANIA STATION

Engine(s) not coupled to cars must not be left standing unattended in Pennsylvania Station, New York, on tracks 1 through 21, inclusive.

116-T1. OPERATING FROM OTHER THAN THE LEADING END WITH PASSENGER EQUIPMENT: NEW YORK PENN STATION

In the application of SI 116-S2 within New York Penn Station, a back-up hose or the emergency brake valve must be used by the crew on the leading end of the move when operating from other than the leading end with passenger equipment whether occupied or unoccupied.

Prior to beginning the movement, the employee on the leading end must test the back-up hose in accord with AMT-3 Instruction 5.4.2, or emergency brake valve (other than on a properly pointed Locomotive) by initiating an emergency brake application and the engineer must inform the employee that an emergency application has occurred. (The Note in AMT-3 5.4.3 does not apply.)

Note: Train inspection and standing train brake test requirements do not apply when testing the back-up hose or emergency brake valve as required by this Special Instruction. The Engineer is required to make a Running Brake Test as per AMT-3 Instruction P4.2.4 or NP4.2.5.

Exception: Movement may be made without a back-up hose or crew member in position to operate the emergency brake valve when a full baggage car is on the leading end of the movement and/or conditions make it unsafe for the crew member to ride on the side of the leading car. In such a case, the crew member must walk ahead of the train to direct movement.

132-T1. TRACKS AND SWITCHES OUT OF SERVICE

The tracks and switches listed below are out of service for train movements, except when such movements are personally supervised by an MW Foreman or MW Supervisor, or when movement consists entirely of track cars.

If a remotely controlled switch provides access to an affected track, the Operator or Dispatcher must apply blocking device protection to prevent the accidental routing of trains to that track. If a hand operated switch provides access to an affected track, the last Engineering Department employee to use the switch must spike the switch to prevent its accidental use.

Location	Track/Switch
A-Yard E	Tracks 4E, 5E, 6E.
Q Int	Sub 4 Track; Q Spur between barricades erected 50 feet west of No. 49 crossover in reverse position and a barricade erected 50 feet east of No. 50 turnout in normal position.
	No. 4 Lead
	No. 5 Lead

138-T1. SUNNYSIDE YARD - COBRA CROSSING

Equipment must not be left standing closer than 15 feet to the first COBRA crossing west of Honeywell Ave. OH Br (first OH Br west of R Int Station), in order to increase visibility at the crossing.

277-T1. DUPLICATE SIGNALS

Duplicate signals are on the left side of the track at:

Signal 2E11, trk 2 East River Tunnel, designated R2E11.

Signal 2E21, trk 2 East River Tunnel, designated R2E21.

Signal 4E21, trk 4 East River Tunnel, designated R4E21.

Duplicate signals are on the right side of the track at:

Signal 3E21, trk 3 East River Tunnel, designated R3E21.

277-T2. NON-CONFORMING ASPECTS: A, KN, C, & JO

The signal aspects illustrated at right, which are not in conformity with typical aspects, are in service between the western limits of **A & KN** Interlockings, and the eastern limits of **C & JO** Interlockings. Even though these signals are numbered with a lever number and an "E" or "W", their most restrictive aspect is STOP:

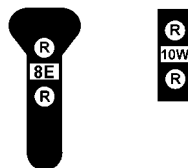

NAME: Stop Signal
INDICATION: Stop

EXCEPTION: Signals W-04 on tracks 1X and 2X, illustrated at right, are automatic signals, and their most restrictive aspect is Stop & Proceed:



NAME: Stop and Proceed
INDICATION: Shown in Rule 291

277-T3. HAROLD INTERLOCKING

A white arrow (Fig. A) is in service on the eastward Interlocking Signal No. 800E (On LIRR Port Washington No. 1 Track 1580 feet east of Harold Int. Station).

A white arrow (Fig. B) is in service on the eastward pedestal type Interlocking Signals No. 856E (On LIRR Port Washington Branch No. 2 track 330 feet east of Harold Int. Station), No. 858E (On LIRR Main Line No. 2 track 330 feet east of Harold Int. Station).

Illuminated arrow indicates that the route is lined to the Port Washington Branch.

All Amtrak trains scheduled for the NYS Line must stop clear of the interlocking signal if the arrow is lighted, and contact PSCC immediately for instructions.

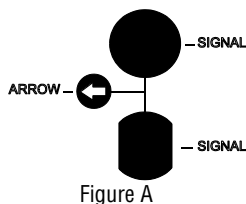

Figure A

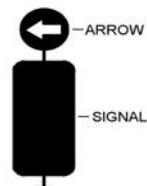
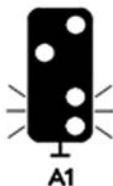

Figure B

277-T4. NON-CONFORMING ASPECT: HAROLD INTERLOCKING

The following signal aspects, not in conformity with the typical aspects illustrated in the NORAC Operating Rules, are in service at Harold Interlocking:



NAME: Approach Limited
INDICATION: See Rule 281b

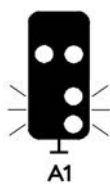

NAME: Limited Clear
INDICATION: See Rule 281c

550-T1. LONG ISLAND RAILROAD TRAINS

Long Island Railroad trains equipped with Automatic Speed Control in operative condition for the direction they are to move will be considered as meeting the requirements of the **Rules** in the same manner as if they were equipped with cab signals.

If Automatic Speed Control fails, it will be cut out and the movement will proceed governed by fixed signal indications but not exceeding 30 miles per hour. The failure must be reported immediately to the PSCC dispatcher via radio when operative. A LIRR train reporting a failure of the Automatic Speed Control system on which the **ASC cab signal indicator and warning device are operative** may be given permission by the PSCC dispatcher to proceed in accordance with indications on the cab signal indicator and fixed signals, not exceeding 60 MPH.

613-T1. A, JO, KN & C - LEADING END OF TRAIN STOPPED BETWEEN SIGNALS

- a. When the leading end of a train is stopped between signals at A, JO, KN, & C and:
 1. There are one or more switches between the train and the next signal,
or
 2. The next signal displays Stop Signal,
the train must not begin movement toward an interlocking signal until a crew member observes and verbally notifies the Engineer that the first interlocking signal to the rear of the leading end for the direction of movement is displaying a proceed aspect. When such observation is not possible, the Engineer must contact the Dispatcher to receive verbal permission to proceed.
- b. Verbal Permission to Proceed - In the application of NORAC Rules 241 and 613:
 1. Verbal authority to proceed must **not** be issued until the exact location of the train has been determined, which must include track number, and signal number or other physical characteristic. Additionally, the signal to the rear of the leading end of the train must be displayed when possible ("call-on").
 2. The Dispatcher must issue verbal permission to proceed in the following manner: *"Amtrak Train 232 engine 700 proceed west on body track 6 Penn Station up to signal No.132W"*. The receiving employee must repeat this permission and the Dispatcher must then confirm it. Movement may then proceed at Restricted Speed to the next signal.
- c. When the leading end of a train is stopped between signals, the train may proceed without observing the first interlocking signal to the rear of the leading end of the train or contacting Dispatcher, if:
 1. There are no switches between the train and the next signal,
AND
 2. The next signal displays a proceed aspect.

701-T1. SUNNYSIDE YARD - RADIO TRANSMISSIONS

Yard radio frequency 036-036 is to be used by all train and engine movements within Sunnyside Yard, Loop Tracks, and Sub Tracks when communicating with the East end and West end Yardmasters, and the Operators at Q and R Interlocking Stations. Road channel 060-060 in service at F.

Except in an emergency, M/W, C&S and B&B employees must use radio channel 027-027 for all transmissions in Sunnyside Yard. Yardmasters and Operators at Q and R Interlocking Stations are equipped with radio channel 027-027.

Red signs with white lettering are in service at the following locations to indicate the proper radio frequency to be used :

- Loop Tracks 1 & 2: East end of car washing machine
- Sub Tracks 1, 2 & 3: West of former F Int Station

706-T1. PORTABLE RADIO TRANSMISSIONS WITHIN THE EAST RIVER TUNNELS

“NYP Road Rptr” channel is in service for portable radios within the North River, East River and Empire Tunnels. Lower powered portable radio transmissions made on “NYP Road Rptr” within the tunnels are picked up by a repeater and retransmitted on Road Channel 060 at high enough power to be received by portable and/or engine radios also located within the tunnels. While the “NYP Road Rptr” channel transmits on the repeater frequency, it receives on Road Channel 060.

Note: No adjustment is necessary for engine radios to communicate with portable radios while within the tunnels.

The Dispatcher at PSCC receives all transmissions made within the tunnels on Road Channel 060 or “NYP Road Rptr”.

708-T1. PSCC

In the application of Rule 708, the terms “PSCC” or “Penn Station Central Control” **must** be used when originating or initially responding to a radio call in which PSCC is involved.

900-T1. DISPATCHERS ASSIGNED TERRITORIES

DISPATCHER	TERRITORY
Penn Station Central Control	Harold (inclusive) to A (inclusive).
Section A	R and Q interlockings.

940-T1. CREWS IN YARD AND YARD-RELAY SERVICE –

950-T1. NEW YORK TERMINAL DISTRICT

Crews in yard-relay service must communicate with the Yardmaster at PSCC immediately upon arrival in Penn Station.

Yard crews working within Penn Station must communicate with the Yardmaster at PSCC when initially signing up, and upon completion of the move they were assigned.

Yard crews working within Sunnyside Yard must communicate with the Yardmaster at the High Speed Rail Facility when initially signing up, and upon completion of the move they were assigned.

Yard crews must contact an Amtrak Terminal Services supervisor, prior to marking off with the Crew Dispatcher.

940-T2. CREWS IN ROAD SERVICE – PENNSYLVANIA

950-T2. STATION, NEW YORK

When signing up in New York, T&E crews in road service must check an available electro-writer screen as soon as practicable to determine the station track number for their assigned train. If unable to locate their assigned train on an electro-writer screen no less than 10 minutes prior to scheduled departure, they must report to the Terminal Operations Center (TOC) to obtain their assigned train's station track number, in order to avoid undue delay.

940-T3. AMTRAK TRAINS RECEIVING PASSENGERS: NY PENN STATION

Amtrak trains receiving passengers in New York Penn Station **must not** depart until permission has been received from Station Services personnel or a manager. If unable to contact Station Services or a manager, the Conductor must contact the PSCC Dispatcher via radio channel 060-060.

941-T1. PENN STATION JO TO A - PLATFORM GAP

Due to excessive gap between train and the passenger platform adjacent to No. 12 Track, from the west end of the platform to a point 170 feet east thereof, crews of trains platforming in this area must ensure that doors are protected to avoid injury.

***This
Page
Intentionally
Left
Blank***

MAIN LINE—NEW YORK TO PHILADELPHIA (NYP)

STATIONS	MP	INT	PS	NOTES
NEW YORK (Penn Station)	0.0	...	X	...
A R-PSCC (New York Terminal District) (Hudson Line)	0.2	X	...	17
NEW YORK-NEW JERSEY STATE LINE	1.2
CP MID R-PSCC	1.5	10
WEEHAWKEN SHAFT	1.8
BERGEN R-PSCC	3.7	X	...	16
ALLIED R-Section A TD	4.0	X	...	16
ERIE R-Section A TD	4.7	X	...	16
SECAUCUS	5.0	...	X	...
LACK R-Section A TD	5.1	X	...	16
PORTAL R-Section A TD (Movable Bridge)	6.0	X	...	16
SWIFT R-Section A TD	7.2	X	...	16
HUDSON R-Section B TD (Hudson Line NJT; Running Trks 5-7-8)	8.3■ 7.0□	X	...	5, 16
REA R-Section B TD (Running Trks 5-6-7-8)	7.8	X	...	5
HARRISON	8.3	...	X	...
DOCK (Movable Bridge)	8.5	X	...	7
NEWARK	8.8	...	X	...
CLIFF R-Section B TD	9.7	X	...	3
HUNTER R-Section B TD (Lehigh Line Conn. - See page 248)	10.5	X	...	16
NEWARK INTERNATIONAL AIRPORT	11.2	...	X	...
HAYNES R-CETC-9 TD	11.3	X	...	11, 16
LANE R-CETC-9 TD (Lane Running Track-C.R.C.)	12.3	X	...	16
NORTH ELIZABETH	13.0	...	X	...
ELIZABETH	14.1	...	X	...
ELMORA R-CETC-9 TD	14.7	X
LINDEN	17.3	...	X	...
MERCK R-CETC-9 TD	18.7	X	...	13
NORTH RAHWAY	18.8
RAHWAY	19.5	...	X	...
UNION R-CETC-9 TD (North Jersey Coast Line-NJT)	19.7	X	...	16
ROADS R-CETC-9 TD	20.6	X	...	14
ISELIN R-CETC-8 TD	22.8	X	...	16
METRO PARK	23.2	...	X	...
MENLO R-CETC-8 TD	23.7	X	...	16
METUCHEN	25.8	...	X	...
LINCOLN R-CETC-8 TD	26.0	X

MAIN LINE—NEW YORK TO PHILADELPHIA (NYP)

STATIONS	MP	INT	PS	NOTES
EDISON R-CETC-8 TD	28.1	X	...	1
EDISON STATION	28.9	...	X	...
NEW BRUNSWICK	31.4	...	X	...
COUNTY R-CETC-8 TD (Millstone & No. 5 Running Tracks)	32.8	X	...	4, 16
JERSEY AVENUE	33.1	...	X	...
DELCO R-CETC-8 TD	33.6	X	...	15, 16
ADAMS R-CETC-8 TD	37.2	X	...	11, 16
MIDWAY R-CETC-8 TD (Amboy Sec. Trk.-C.R.C.)	41.3	X
PRINCETON JCT	47.1	...	X	...
CP CLARK R-CETC-8 TD	48.7
HAMILTON	53.0	...	X	...
HAM R-CETC-7 TD (No. 5 Running & Naught Running)	55.7	X	...	6
FAIR R-CETC-7 TD (Naught Running)	56.4	X	...	6
TRENTON	56.7	...	X	...
STATE LINE (New Jersey-Pennsylvania)	57.7
MORRIS R-CETC-7 TD (Morrisville Line CRC)	58.3	X	...	12, 16
LEVITTOWN-TULLYTOWN	63.3	...	X	...
GRUNDY R-CETC-7 TD	65.3	X
BRISTOL	66.5	...	X	...
CROY R-CETC-7 TD	68.3	X	...	2
CROYDON	69.6	...	X	...
EDDINGTON	71.3	...	X	...
CORNWELLS HEIGHTS	72.5	...	X	...
ANDALUSIA	73.7
TORRESDALE	74.6	...	X	...
DIVISION POST	76.0
HOLMESBURG JCT.	77.2	...	X	...
HOLMES R-CETC-6 TD	77.2	X
TACONY	78.2	...	X	...
WISSINOMING	79.3
BRIDESBURG	80.1	...	X	...
FRANKFORD	80.9
FRANKFORD JCT.	81.8
SHORE R-CETC-6 TD (NJT AC Line) (Delair Branch-CRC)	82.1	X	...	16
CLEARFIELD R-CETC-6 TD	84.5	X
NORTH PHILADELPHIA	85.0	...	X	...
LEHIGH R-CETC-6 TD (Chestnut Hill Branch-SEPTA)	85.1	X
MANTUA R-CETC-6 TD	87.2	X
GIRARD R-CETC-6 TD	87.7	X

MAIN LINE—NEW YORK TO PHILADELPHIA (NYP)

ZOO	(ML-Philadelphia to Harrisburg) (36th St Connection) (Main Line-SEPTA)	88.0	8, 9
-----	--	------	-----	-----	------

The direction from New York to Zoo is westward.

- Mile Posts A to former Hudson Interlocking Station are numbered from New York.
- Mile Posts former Hudson Interlocking Station to Zoo are numbered from Jersey City.

See SI 161-N1 (page 190) for duplicate Mile Posts.

Note 1: Int Rules apply on No. 0, 1 and 2 trks only.

Note 2: Int Rules apply on No. 1 trk only.

Note 3: Int Rules apply on No. 1, 2 and 3 trks only.

Note 4: Millstone Running Trk and No. 5 Running Trk between County & End of Track, controlled by CETC-8 TD.

Note 5: Nos. 5, 6, 7 & 8 Running Tracks between Hudson & Rea, controlled by Section B TD.

Note 6: No. 5 Running Track between Ham & MP 55, and Naught Running Track between Fair & MP 54.8, controlled by CETC-7 TD. See SI 241-N1, page 190.

Note 7: Int Station with Amtrak Road Radio Channel 060-060.

Note 8: In service as an Int Station for PH Line & 36 Street Connection only, with Amtrak Road Radio Channel 054-054 and Conrail Road Radio Channel 046-046.

Note 9: No. 3 Main Track (“Berry Trk”) between connection with N.Y. & P. Subway Trk. (north of Zoo Int. Sta.) and 36th St., controlled by CETC-6 TD.

Note 10: Eastward controlled signals.

Note 11: Int Rules apply on No. 1 and 2 trks only.

Note 12: Road radio channel 060-060 in service east of MP 76. Road radio channel 054-054 in service west of MP 76. (See SI 707-N1, page 194.)

Note 13: Interlocking rules apply on A track only.

Note 14: Interlocking rules apply on No. 4 and B tracks only.

Note 15: Interlocking Rules apply on No. 3 and 4 Tracks only.

Note 16: Equipped with movable point frogs. See SI 80-S1.

Note 17: Equipped with slip switches. See SI 80-S1.

240-N1. SIGNAL RULES and CURRENT OF TRAFFIC

251: On trks where Rule 251 is in effect, the letter in parentheses () denotes the current of traffic: E=East, W=West, N=North, S=South. ABS Rules & CSS Rules 550—561 are in effect for movements with the current of traffic. Non-Signalled DCS Rules are in effect for movements against the current of traffic.

261: On trks where Rule 261 is in effect, ABS Rules & CSS Rules 550 through 561 are in effect for movements in both directions.

562: On tracks where Rule 562 is in effect, Rule 261, ABS Rules, and CSS Rules 550 through 563 (except Rules 554 and 556), are in effect for movements in both directions.

Int: indicates Interlocking Rules in effect.

562/Int: On tracks where Rule 562 and Interlocking Rules are effect, CSS Rules 550 through 563 (except Rules 554 and 556) are in effect for movements in both directions.

ACSES Rules: See SI 580-N1.

Locations	Tracks from North to South				Notes
	4	3	2	1	
A & Bergen	...	562	562
Bergen & Hudson	...	562/Int	562/Int
Allied & Portal: Track A					562/Int
Erie & Lack: Track B					562/Int

240-N1. (Cont'd)					
Locations	Tracks from North to South				Notes
	4	3	2	1	
Hudson & Rea	...	562/Int	562/Int	Int	3
Rea & Dock	...	Int	Int	Int	3
Dock & Cliff	261	261	261	251(E)	1
Cliff & Elmora	261	261	261	261	...
Hunter & Lane: Track 5, Track A					261
Elmora & Merck: Track A					251(E)
Elmora & Union	251(W)	261	261	251(E)	...
Track B					251(W)
Merck & Union: Track A					Int
Union & Roads	Int
Track B					Int
Union & Iselin	...	261	261	251(E)	2
Roads & Iselin	251(W)
Iselin & Menlo	Int	Int	Int	Int	3
Menlo & Lincoln	251(W)	261	261	251(E)	...
Lincoln & Edison	251(W)	261	261	261	...
Track No. 0					261
Edison & County	251(W)	261	261	251(E)	...
County & Midway	562	562	...
County & Delco	562/Int.	562/Int.
Delco & Midway	562	562
Midway & CP Clark	562	562	562	562	...
CP Clark & Ham	562	261	261	562	...
Ham & Fair	Int	Int	Int	Int	3
No. 5 Track					Int (Note 3)
Fair & Morris	261	261	261	261	...
Morris & Grundy	251(W)	261	261	251(E)	...
Grundy & Holmes	251(W)	261	261
Grundy & Croy	261	...
Croy & Holmes	251(E)	...
Holmes & Shore	261	261	261	261	...
Shore & Clearfield	261	261	261	261	...
Clearfield & Lehigh	Int	Int	Int	Int	3
Lehigh & Mantua	261	261	261	261	...
Mantua & Girard	Int	Int	Int	Int	3, 4
Connection with N.Y. & P. Subway Trk. (north of Zoo Int. Sta.) & 36th St	Interlocking Rules in effect on No. 3 track ("Berry" Track)				5
Note 1: Within Dock Int., trks 5 & A are designated Main Trks.					
Note 2: Between Union & Graw (NJT), Int Rules & CSS Rules in both directions are in effect on the Eastward connecting trk and on the Eastward & Westward Tunnel trks.					
Note 3: CSS Rules in effect for movements in both directions.					
Note 4: Tail Track - Int Rules in effect, and CSS Rules in effect in both directions.					
Note 5: CSS Rules in effect on No. 3 trk. for southward movements. Controlled by CETC-6 TD.					

37-N1. PASSENGER TRAINS and FREIGHT TRAINS MAXIMUM SPEEDS and SPEED RESTRICTIONS, UNLESS OTHERWISE RESTRICTED

Locations and speeds shown in normal type are maximum authorized speeds. Locations and speeds shown in **bold type** are speed restrictions. *Maximum equipment speeds listed in SI 37-S5 (page 289) must not be exceeded.*

Where speeds change at an interlocking and the specific point where the speed change occurs is not specified, the lower speed will apply through the entire interlocking.

PASSENGER TRAIN TYPE "A" & "B" SPEEDS								
Train Type A refers to High Speed Trainsets (HST) with tilt system active .								
Train Type B refers to (1) HST's with tilt system disabled ; and (2) trains consisting exclusively of HHP-8, AEM-7, ACS-64, P40BH, P42BH, P32AC-DM, or P32-BWH engines, and Amfleet, Horizon, Capitoliner Control/ Conference Cars, LDSL Baggage Cars 61000-61084, MARC III control/coach cars, or US DOT test car DOTX 216.								
Between/At	Train Type "A"				Train Type "B"			
	Track Nos.				Track Nos.			
	4	3	2	1	4	3	2	1
West limits A & West Portal North River Tunnels	...	60	60	60	60	...
West Portal North River Tunnels & first undergrade bridge west of MP 3	...	60	90	60	90	...
First undergrade bridge west of MP 3 & Bergen	...	90	90	90	90	...
Cv west of west portal, North River Tunnels	...	75	75	75	75	...
Bergen & NY MP 7.7	...	90	90	90	90	...
Portal Movable Br (MP 6.1)	...	60	60	60	60	...
Track A between:								
Allied & Erie								75 MPH
Erie & Lack								45 MPH
Lack & Portal								70 MPH
Track B between:								
Erie & Lack								60 MPH
NY MP 7.7 & Hudson Int	...	60	60	60	60	...
Hudson Int & Rea Int	...	60	60	45	...	60	60	45
Rea Int & JC MP 7.8	...	60	60	35	...	60	60	35
JC MP 7.8 & east limits of Dock Int	...	45	45	35	...	45	45	35
East limits of Dock Int & west end Passaic River Bridge	30	45	45	35	30	45	45	35
West end Passaic River Br & MP 9	35	35	35	35	35	35	35	35
Dock Int: Tracks A & 5	35 MPH							
MP 9 & Hunter	70	70	70	70	70	70	70	70
Hunter Int: Tracks A & 5	45 MPH							
Hunter & Elmora	90	110	110	90	90	110	110	90
Hunter & Lane: Tracks A & 5	80 MPH							
First Cv west of Hunter: Track 5	60 MPH							
First Cv west of MP 14	55	85	85	55	55	75	75	55
Cv east of Elmora	55	80	80	55	55	70	70	55
Elmora Int	60	80	80	60	60	80	80	60
Elmora & Union	90	125	125	90	90	125	125	90

37-N1. (Cont'd)

PASSENGER TRAIN TYPE "A" & "B" SPEEDS

Between/At	Train Type "A"				Train Type "B"			
	Track Nos.				Track Nos.			
	4	3	2	1	4	3	2	1
Track A between:								
Elmora & Automatic Block Signal 158	75 MPH							
Automatic Block Signals 158 & 176	80 MPH							
Automatic Block Signal 176 & Union	70 MPH							
Track B between:								
Elmora & Roads:	75 MPH							
Union & Graw	All Routes 30 MPH							
Union & Lincoln	90	110	110	90	90	110	110	90
First Cv east of MP 24	95	90	...
First Cv west of MP 24	...	105	105	90	90	...
Cv at MP 25	95	95	...
Lincoln & MP 28	90	110	110	100	90	110	110	100
Edison & Lincoln: No. 0 Trk	15 MPH							
First Cv west of Lincoln	80	95	95	80	80	80	80	80
Second Cv west of Lincoln	...	110	110	90	...	90	90	90
MP 28 & County	90	125	125	100	90	125	125	100
County & MP 54	110	135	135	110	110	135	135	110
Cv at MP 34	...	130	130	130	130	...
Cvs MP 39 & MP 40.2	...	130	130	130	130	...
MP 54 & Ham	110	135	135	110	110	135	135	110
Ham & Morris	80	110	110	80	80	110	110	80
No. 5 Track Between:								
• East limit Ham Int & A point 15 feet east of the facing point switch for eastward movement to No. 4 trk at Ham	5 MPH							
• A point 15 feet east of the facing point switch for eastward movement to No. 4 trk at Ham & East limit Fair Int.	30 MPH							
• East limit Fair Int & West end Trenton Station	15 MPH							
Fair Int:								
No. 7 Track, South High, North Low, Wall and Hill Tracks	15 MPH							
Movements from Nos. 5 or 7 station trks to Trk No. 4 thru turnouts at west end of Trenton station								
	10 MPH							
First Cv west of Trenton	65	65	65	95	...	65
Morris Int	100	100	...
Morris & MP 62	100	125	125	100	100	110	125	100
First Cv west of Morris	110	...
Cv MP 61 & MP 62	115	...
MP 62 & MP 76	100	125	125	100	100	125	125	100
Cv east of Grundy	120	120	...
Cv west of Grundy	115	115	...
Cv west of Croydon	...	120	120	105	105	...
Cvs MP 74 & MP 75	80	105	105	80	80	90	90	80
First Cv west of MP 75	110	120	...
MP 76 & Holmes	100	125	125	100	100	110	110	100
Holmes & Shore	90	110	110	90	90	110	110	90

37-N1. (Cont'd)

PASSENGER TRAIN TYPE "A" & "B" SPEEDS

Between/At	Train Type "A"				Train Type "B"			
	Track Nos.				Track Nos.			
	4	3	2	1	4	3	2	1
Cv West of MP 81	60	80	80	60	60	60	60	60
Cv east of Shore	50	60	60	50	50	50	50	50
Shore & Clearfield	70	80	80	70	70	80	80	70
Cv MP 84 & 2nd St OH Br	65	65	65	65	65	65	65	65
Clearfield & west limits Lehigh Int.	50	60	60	50	50	60	60	50
Cvs east & west of North Philadelphia Station	40	40
West limits Lehigh Int. & East limits Mantua	70	80	80	70	70	70	70	70
East limits Mantua & Girard Ave UG Br	60	60	70	70	60	60	70	70
Mantua Int & Girard Int: Tail Track	30 MPH							
Girard Ave UG Br & Zoo Int Station	30	30	30	30	30	30	30	30
Connection N.Y. & P. Subway Trk. (just north of Zoo Int. Station) & 36th Street	...	10	10

PASSENGER TRAIN TYPE "C" & "D" SPEEDS

Train Type C refers to passenger trains that do not meet the criteria for train types A, B, or D.

Train Type D refers to passenger trains with mail, baggage or express cars in consist, that meet the Train Type D criteria defined in SI 37-S8, page 304.

NOTE 1: Train Type "D" trains must not exceed 60 MPH when operating with inoperative cab signals.

Between/At	Train Type "C"				Train Type "D"			
	Track Nos.				Track Nos.			
	4	3	2	1	4	3	2	1
West limits A & West Portal North River Tunnels	...	60	60	45	45	...
West Portal North River Tunnels & first undergrade bridge west of MP 3	...	60	75	45	60	...
First undergrade bridge west of MP 3 & Bergen	...	75	75	60	60	...
Bergen & MP W4.5	...	90	90	75	75	...
Track A between: Allied & Erie	75 MPH				75 MPH			
Erie & Lack	45 MPH				45 MPH			
Lack & Portal	70 MPH				60 MPH			
Track B between: Erie & Lack	60 MPH				60 MPH			
MP W4.5 & NY MP 7.7	...	90	90	75	75	...
Portal Movable Br (MP 6.1)	...	60	60	60	60	...

37-N1. (Cont'd)

PASSENGER TRAIN TYPE "C" & "D" SPEEDS

Between/At	Train Type "C"				Train Type "D"			
	Track Nos.				Track Nos.			
	4	3	2	1	4	3	2	1
NY MP 7.7 & Hudson Int	...	60	60	45	45	...
Hudson Int & Rea Int	...	60	60	45	...	45	45	30
Rea Int & JC MP 7.8	...	60	60	35	...	45	45	20
JC MP 7.8 & east limits Dock Int	...	45	45	35	...	30	30	20
East limits of Dock Int & west end Passaic River Bridge	30	45	45	35	20	30	30	20
West end Passaic River Br & MP 9	35	35	35	35	20	20	20	20
Dock Int: Trks. A & 5	35 MPH				25 MPH			
MP 9 & Signal Br 96-97	70	70	70	70	55	55	55	55
Signal Br 96-97 & Hunter	70	70	70	70	55	55	55	55
Hunter Int: Trks. A & 5	45 MPH				30 MPH			
Hunter & Elmora	90	110	110	90	75	90	90	75
Hunter & Lane: Tracks A & 5	80 MPH							
First Cv west of Hunter: Track 5	60 MPH							
First Cv west of MP 14	55	55	55	55	55	55	55	55
Cv east of Elmora	55	55	55	55	55	55	55	55
Elmora Int	60	60	60	60	60	60	60	60
Elmora & MP 20	90	110	110	90	75	90	90	75
Track A between:								
Elmora & Automatic Block Signal 158	75 MPH				60 MPH			
Automatic Block Signals 158 & 176	80 MPH				65 MPH			
Automatic Block Signal 176 & Union	70 MPH				55 MPH			
Track B between:								
Elmora & Roads	75 MPH				60 MPH			
Union & Graw	All Routes 30 MPH				All Routes 20 MPH			
MP 20 & Lincoln	90	110	110	90	75	90	90	75
First Cv east of MP 24	...	90	90
First Cv west of MP 24	...	90	90
Cv at MP 25	...	95	95
Lincoln & County	90	110	110	100	75	90	90	85
Edison & Lincoln: No. 0 Trk	15 MPH							
First Cv west of Lincoln	80	80	80	80	...	80	80	80
Second Cv west of Lincoln	...	90	90	90
Third Cv west of Lincoln	...	100	100
County & MP 54	110	110	110	110	90	90	90	90
MP 54 & Morris	80	110	110	80	65	90	90	65

37-N1. (Cont'd)

PASSENGER TRAIN TYPE "C" & "D" SPEEDS

Between/At	Train Type "C"				Train Type "D"			
	Track Nos.				Track Nos.			
	4	3	2	1	4	3	2	1
No. 5 Track Between:								
● East limit Ham Int & A point 15 feet east of the facing point switch for eastward movement to No. 4 trk at Ham	5 MPH							
● A point 15 feet east of the facing point switch for eastward movement to No. 4 trk at Ham & East limit Fair Int.	30 MPH							
● East limit Fair Int & West end Trenton Station	15 MPH							
Fair Int:								
No. 7 Track, South High, North Low, Wall and Hill Tracks	15 MPH							
Movements from Nos. 5 or 7 station trks to								
Trk No. 4 thru turnouts at west end of Trenton station	10 MPH							
First Cv west of Trenton	65	95	95	65
Morris Int	...	100	100
Morris & Holmes	100	110	110	100	85	90	90	85
First Cv west of Morris	...	100
Cv west of Croydon	...	105	105
Cvs MP 74 & MP 75	80	90	90	80	80	80
Holmes & Shore	90	100	100	90	75	85	85	75
Wisconsinomg & MP 81:								
Westward only	...	90	90	75	75	...
Cv West of MP 81	60	60	60	60	60	60	60	60
Cv east of Shore	50	50	50	50	50	50	50	50
Shore & Clearfield	70	70	70	70	55	55	55	55
Cv MP 84 & 2nd St OH Br	65	65	65	65
Clearfield & west limits Lehigh Int.	50	60	60	50	35	45	45	35
Cvs east & west of North Philadelphia Station	40
West limits Lehigh Int & East limits Mantua	70	70	70	70	55	55	55	55
East limits Mantua & Girard Ave UG Br	60	60	70	70	45	45	55	55
Mantua Int & Girard Int: Tail Track	30 MPH							
Girard Ave UG Br & Zoo Int Station	30	30	30	30	20	20	20	20
Connection N.Y. & P. Subway Trk. (just north of Zoo Int. Station) & 36th Street	...	10	10

FREIGHT TRAIN TYPE "E" SPEEDS

Between/At	Train Type "E"			
	Track Nos.			
	No. 4	No. 3	No. 2	No. 1
West limits A & West Portal North River Tunnels	...	20	20	...
West Portal North River Tunnels & eastern limits Hudson Int	...	20	20	...
Allied & Portal:				
Tracks A & B	20 MPH			
Eastern Limits of Hudson Int & west end Passaic River Bridge	25	20	20	20

37-N1. (Cont'd)				
FREIGHT TRAIN TYPE "E" SPEEDS				
Between/At	Train Type "E"			
	Track Nos.			
	No. 4	No. 3	No. 2	No. 1
West end Passaic River Br & Signal Br 96-97	20	15	20	20
Dock Int: Tracks A & 5	20 MPH			
Signal Br 96-97 & Hunter	20	15	20	30
Hunter Int: Tracks A & 5	10 MPH			
Hunter & Elmora	25	25	25	20
Hunter & Lane: Tracks A & 5	15 MPH			
Elmora & Union: Track A	30 MPH			
Elmora & Roads: Track B	20 MPH			
Union & Graw	All Routes 20 MPH			
Union: Diverging movements between Eastward/Westward Tunnel Tracks & NEC Main Tracks	10 MPH			
Elmora & MP 20	35	35	35	35
MP 20 & Lincoln	25	25	25	25
Lincoln & MP 28	35	35	35	35
MP 28 & County	30	30	30	30
Edison & Lincoln: No. 0 Track	15 MPH			
County & MP 44	45	45	45	45
MP 44 & MP 54	50	50	50	50
MP 54 & Fair	35	30	30	30
No. 5 Track Between:				
● East limit Ham Int & A point 15 feet east of the facing point switch for eastward movement to No. 4 trk at Ham	5 MPH			
● A point 15 feet east of the facing point switch for eastward movement to No. 4 trk at Ham & East limit Fair Int.	25 MPH			
● East limit Fair Int & Fair Int Station	5 MPH			
● Fair Int Station & West end Trenton Station	10 MPH			
Fair Int.	20	20	20	20
No. 7 Track, South High, North Low, Wall and Hill Tracks	5 MPH			
Fair & Morris	35	30	30	30
Morris & MP 62	40	40	40	40
MP 62 & Grundy	50	50	50	50
Grundy & Croydon	50	50	50	30
Cv West of Grundy	...	45	45	...
Croydon & Holmes	50	50	50	50
Holmes & MP 81	50	45	45	45
MP 81 & Shore	30	25	25	25
Shore & Clearfield	40	40	30	30
Clearfield & west limits Lehigh Int.	30	30	30	30
West limits Lehigh Int & Girard Ave. UG Br.	30	30	30	30
Mantua Int & Girard Int: Tail Track	10 MPH			
Girard Ave. UG Br & Zoo Int Station	15	15	15	20
Connection N.Y. & P. Subway Trk. (just north of Zoo Int. Station) & 36th Street	...	10

1-N1. TSRB CHANGES RELAYED BY TRAIN DIRECTOR AT DOCK

Train Directors at Dock who have received a copy of the current TSRB may be directed by the Dispatcher to relay TSRB additions or cancellations to trains. Train Directors charged with this responsibility will be governed by the delivery and blocking device procedures in Special Instruction 1-S4 (page 269).

19-N1. STATE OF NEW JERSEY

In the State of New Jersey: Trains and engines will use one long sound of the engine horn or whistle approaching a passenger station on a track adjoining platform during daylight hours. During the hours of darkness such trains shall not be required to sound a horn or whistle except when the engineman observes a person or persons on or near a station platform. This signal shall not supersede other whistle alarm signals in effect.

19-N2. ENGINE WHISTLE OR HORN: SECAUCUS STATION

Except when approaching Roadway Workers or in an emergency, trains must **not** sound their engine whistle or horn while within the confines of Secaucus Station overbuild. This restriction is intended to prevent hearing loss injuries to passengers as well as employees working in the station.

20-N1. ENGINE BELL: SECAUCUS STATION

Trains equipped with an engine bell must sound it continuously while moving within the confines of Secaucus Station overbuild.

34-N1. STATION STOPS: SECAUCUS STATION

Unless otherwise instructed by the Dispatcher, trains making station stops at Secaucus Station must operate according to the following instructions, whenever possible:

- (1) **Eastward trains** should stop west of Erie Interlocking, and must not enter Erie Interlocking until a signal to proceed is received from a member of the train crew.
- (2) **Westward trains** should stop east of Lack Interlocking, and must not enter Lack Interlocking until a signal to proceed is received from a member of the train crew.

These instructions will enable the Dispatcher to adjust the operating flow as needed. If a train encounters any problem that prevents it from proceeding, the dispatcher must be notified immediately.

36-N1. TRENTON STATION: 10 - 12 CAR MARKER SIGN

Eastbound trains with ten or more cars making a station stop on No.1 track in Trenton Station must be stopped with the head end of the train adjacent to the 10-12 Car Marker sign on the east end of the Trenton Station platform unless otherwise instructed by the CETC – 7 Train Dispatcher. This is to ensure that all equipment clears the full tension air gap in the catenary system on the west end of the 21 crossover in Fair interlocking. Stopping before the sign is prohibited except in emergencies.

37-N2. SPEEDOMETER CHECKING: MEASURED MILES

The distance between the sets of Mile Posts listed below is a measured mile. White marker posts are installed on both sides of the tracks at locations marked with an asterisk(★).

White marker posts bearing the letters MM (measured mile) are in service for westward movements on:

- ▶ Nos. 2 & 3 tracks between MP 1.7 and MP 2.7.

*MP 4- *MP 5	MP 52-MP 53	MP 68-MP 69
MP 15-MP 16	*MP 53- *MP 54	*MP 73- *MP 74
*MP 30- *MP 31	MP 61-MP 62	*MP 74- *MP 75
MP 44-MP 45	*MP 63- *MP 64	MP 79-MP 80
*MP 45- *MP 46	MP 66-MP 67	MP 81-MP 82

37-N3. MAXIMUM SPEEDS, RUNNING TRACKS

Track	Between	And	Restricted Speed not exceeding	
			Miles Per Hour	
			Psgr	Frnt
Nos. 5 & 6	Hudson	Rea	5	5
Nos. 7 & 8	Hudson	Rea	15	10
Millstone	County	Jersey Ave Road crossing	10	10
No. 5	County	End of Track	5	5
No. 5	Eastward limit Ham Int	MP 55	5	5

37-N4. MAXIMUM SPEEDS, OTHER TRACKS

Location	Track(s)	Restricted Speed not exceeding
East of Ham	No. 5 between MP 55 & east end of track	5 MPH
Holmes	No. 5	5 MPH
All Yard Tracks, Industrial Tracks and Public Delivery Tracks connected with Amtrak Main or Running Tracks		10 MPH

37-N5. MAXIMUM SPEEDS, TURNOUTS & CROSSOVERS

Interlocked Switches:	
Hudson-Turnouts between Nos. 5 & 6 trks.	10 MPH
Lane-To or from Lane Running Trk	10 MPH
Midway-Switch to Yard	10 MPH

37-N6. WRECK AND WIRE TRAINS

Between:	Wire Train	Boom Trailing	Boom Forward
		Miles Per Hour	
		Wreck	Wreck
A & Mantua	50	40	30

Note: Where speed of freight trains is slower than the speeds shown in this instruction, the freight train speed must not be exceeded.

40-N1. ENGINE AND EQUIPMENT RESTRICTIONS

The numbers shown in the columns to the right of each listed location specify the maximum height of the engines and equipment that may be operated. Engine and equipment dimension specifications are assigned in S.I. 37-S5 (page 289) for equipment authorized to operate on the NEC. Notes shown in parentheses in the location column are defined at the end of the table.

Location	Tracks						
	B	4	3	2	1	A	Other
A To Bergen (a)(b)	1	1
Bergen to Lane	4	4	4	4	4	...
Newark: Station Tracks	4
Hunter to Lane: Track 5	4
Lane to Elmora	...	5	5	7	4
Elmora to Union	5	5	5	6	6	7	...
Union to Lincoln	...	6	6	7	7
Lincoln to County	...	6	6	6	6
County to Morris	5	6	6	5
Trenton Station Tracks	5
Morris & MP 76	...	6	6	6	6

Location	Tracks					
	5	4	3	2	1	Other
MP 76 & Holmes	...	6	6	6	6	...
Holmes & Shore	5	5	5	5	6	...
Shore & Lehigh	...	5	5	5	5	...
Lehigh & Mantua	5	2	5	5	5	...
Mantua & Girard	...	4	5	5	4	...
Girard & Zoo (c)	...	3	5	5	4	...

Notes:
(a) Capitoliner Control Car 9637 is prohibited from operating between A and Hudson.
(b) Engines of dimension #2 may operate when verbally authorized by the Dispatcher at PSCC.
(c) The following engines of dimension code 4 listed in SI 37-S5 may operated on No. 4 trk: 4000-4032, 4100-4112, 4135-4144, 4145-4150, 4200-4219, 4300-4303.

41-N1. NEWARK

The movement of any car containing car load shipment of gasoline or explosives is prohibited between Hunter and Harrison.

41-N2. CWR EQUIPMENT-BERGEN and A

Freight trains containing two or more Continuous Welded Rail (CWR) cars coupled to each other must operate No. 2 trk between Bergen and A; No. 11 trk through Penn Station or No. 3 trk between Bergen and A; No. 12 trk through Penn Station with no diverging movements at A. This restriction applies to CWR cars of Foreign Railroads and includes Amtrak equipment in car series 15250-15252, and 15260-15316.

43-N1. EASTWARD SEPTA TRAINS, MORRIS & FAIR

Approaching Morris: Crews of eastward SEPTA trains destined Trenton must notify the CETC 7 Dispatcher prior to passing Morris interlocking when consist of train exceeds 3 cars.

Fair: Eastward SEPTA trains routed to No. 5 track in Trenton Station must not operate east of Fair interlocking signal 5AW without verbal permission of the Dispatcher.

43-N2. WESTWARD NJT TRAINS DEPARTING HAMILTON STATION

Crews of westbound New Jersey Transit trains departing Hamilton must contact the CETC 7 Dispatcher when carrying disabled passengers exiting at Trenton, or when consist of train exceeds eight cars.

47-N1. TRACKS EQUIPPED FOR DC ELECTRICAL OPERATION

Nos. 2 & 3 tracks between A and the west portals of the North River Tunnels, equipped for DC electrical operation.

72-N1. TRAIN INSPECTION DETECTORS

Type of Detector	MP Location	Direction of Operation	Tracks(s)	Recorder Location	Notes
RA HB/DED	29.7	East & West	1, 2, 3, 4	CETC 8	1
HBD	51.9	East & West	1 & 2	Dspr Office	...
			3 & 4	Dspr Office	...
HBD	73.4	East & West	1, 2, 3 & 4	Dspr Ofc-NY & CETC 6	...

Note 1: Transmits only when a defect has been detected, on radio channel 060-060. A defect alarm indication will actuate at the Dspr console. SI 72-S1 applies.

72-N2. WHEEL IMPACT DETECTORS

Wheel impact detectors are installed at the following locations. See SI 72-S8.

MP	Location	Tracks
40.8	Midway	3, 4

104-N1. SWITCHES EQUIPPED WITH ELECTRIC LOCKS

The following hand-operated switches are equipped with an electric lock; permission to occupy Main Track, Interlocking or Controlled Siding must be obtained from the Dispatcher before lock is removed from keeper.

Location	Switch	Notes
839 feet east of MP 13	No. 4 track to Durant Yard	1
4032 feet east of ABS Signal 216	No. 1 track to Colonia Siding	1
3400 feet west of MP 26	No. 0 trk. to west leg of Wye	1
4100 feet west of MP 26	No. 0 trk. to Yard tracks 5 through 9	1
8150 feet west of MP 26	No. 0 trk. to Yard tracks 5 through 9	1
MP 35	No. 1 Track to Adams Siding	1, 2
1655 feet west of MP 38	No.1 Track to Deans Siding	1, 2
MP 46.6	No. 4 track to Nassau Running Trk (NJT)	1
MP 81.3	Frankford Jct Yard	1
MP 82	Single to CR Delair Br.	1

Note 1: To enter side track from Main Track, train must occupy track circuit which extends 50 feet from point of switch, before switch can be opened.

(Notes continued on next page)

104-N1. (Cont'd)

Note 2: The following operations must be conducted in the order specified to ensure that the hand switch will lock and unlock properly, and to prevent track circuits from remaining on the Main Line track.

Operating from Main Line to Siding or Yard:

- 1 Remove padlock from derail switch machine.
- 2 Operate derail machine to the reverse (non-derailing) position.
- 3 Remove padlock from main line switch machine.
- 4 Throw main line switch to the reverse position.
- 5 Make equipment move over the switch to the yard or siding. Entire move must be clear of derail machine.
- 6 Operate derail switch back to normal (derailing) position and replace the padlock.
- 7 Operate main line switch back to normal position and replace the padlock.

Operating from Siding or Yard to Main Line:

- 1 Remove padlock from derail switch machine.
- 2 Operate derail machine to the reverse (non-derailing) position.
- 3 Remove padlock from main line switch machine.
- 4 Operate main line switch machine to the reverse position.
- 5 Make equipment move over switch to main line track. Entire move must be clear of main line switch.
- 6 Operate derail switch back to the normal (derailing) position and replace the padlock.
- 7 Operate main line switch back to the normal position and replace the padlock.

Dispatcher Procedures – Authorization to Occupy Main Track at Adams & Dean Switches:

- 1 Signals governing movement into the block between Adams and County interlockings must display Stop.
- 2 If a signal is cancelled to allow operation of an electrically locked switch, signal time release must be completed before electric lock can be released.

104-N2. NORMAL POSITION OF SWITCHES AND CROSSOVERS AT SPECIFIED LOCATIONS:

Switch location	Connecting	With	Normal Position is for Movement	Note
Naught Running Trk between Ham & Fair	Naught Running Trk	West end of East Barracks Yard	Through on Naught Running Trk	...

114-N1. DIESEL RESCUE ENGINES IN NORTH RIVER TUNNELS

If a diesel engine is used in the North River tunnels to rescue a disabled train, it will not be necessary to shut the diesel engine down if standing for 5 or more minutes, provided the Dispatcher has informed the crew that the tunnel ventilation system is running. Before permitting the engine to enter the tunnel with this assurance, the Dispatcher must communicate with the Manager Train Operations to verify that the tunnel ventilation system has been activated and is functioning.

If catenary power is available on the disabled train and the train's ventilation system is functioning, the ventilation system fresh air intakes should be closed on each occupied car. If this is not possible on the car nearest the diesel rescue locomotive, passengers should be moved from that car when feasible.

132-N1. TRACKS AND SWITCHES OUT OF SERVICE

The tracks and switches listed below are out of service for train movements, except when such movements are personally supervised by an MW Foreman or MW Supervisor, or when movement consists entirely of track cars.

If a remotely controlled switch provides access to an affected track, the Operator or Dispatcher must apply blocking device protection to prevent the accidental routing of trains to that track. If a hand operated switch provides access to an affected track, the last Engineering Department employee to use the switch must spike the switch to prevent its accidental use.

Location	Track/Switch
Lincoln	Lehigh Valley Spur, No. 5 & No. 6 tracks
County	No. 5 Running Trk between east end of trk & barricade 100 ft east of Back Lead Sw.
Grundy	No. 5 trk between MP 64.8 & end of track

161-N1. JERSEY CITY AND NEW YORK MILE POST DESIGNATIONS

Duplicate mile post numbers are used between MP 7.0 and MP 8.3. Any reference in Form D's, Bulletin Orders or TSRB's to mile post numbers between MP 7.0 and MP 8.3, inclusive, must be preceded by either "NY" for New York City mile posts or "JC" for Jersey City mile posts. Example: "Do not exceed 10 MPH between NY MP 7.3 and JC MP 8.3".

162-N1. FORM D's FOR NJT TRAINS

Form D's delivered at New York to NJT trains that turn at South Amboy, Matawan, Montclair State University, Summit, and County will also be in effect on the return trip.

NJT trains that are rerouted to a location other than their scheduled destination must not proceed to new destination until crew has contacted the dispatcher regarding Form D's, TSRB additions and other instructions that may be in effect for the additional territory.

241-N1. STOP SIGNALS

In the application of **Rule 241**, when **Stop Signal** is displayed on a signal at the following locations, the authority to pass it must be obtained through the Operator or Dispatcher listed below:

Location	Track	Governing Movements	Authority Obtained From
987 feet West of MP 7.2	No. 7 Running Track	East	Section B TD
985 feet West of MP 7.2	No. 8 Running Track	East	Section B TD
MP 54.8	Naught Running	East & West	CETC-7 TD

242-N1. SHORE – IMPERFECTLY DISPLAYED SIGNALS

The most restrictive indication that can be given by the dwarf signal governing westward movements on No. 5 track located 48 feet west of the crossover connecting No. 4 and No. 5 tracks, is Restricting.

242-N2. COUNTY – IMPERFECTLY DISPLAYED SIGNALS

The most restrictive indication that can be given by the dwarf signal governing westward movements on the Millstone Running Track (when operating from No. 4 track) is Restricting.

277-N1. FAIR

High color position light interlocking signal governing eastward movements on No. 4 track located adjacent to the east end of the westbound passenger platform and located to the left of No. 4 track.

277-N2. CROY

Home signal governing westward movement on No. 1 track located to the left of No. 1 track.

277-N3. NON-CONFORMING ASPECT: PORTAL TO SWIFT

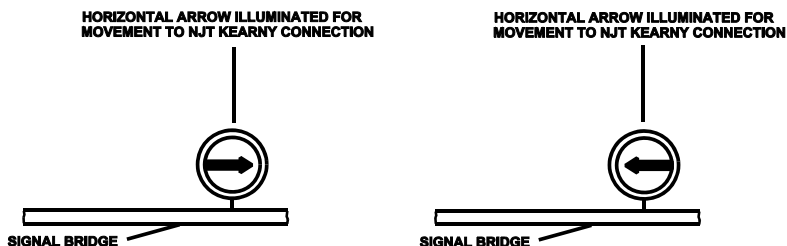

White directional indicator arrows in service for westward movements on No. 2 and No. 3 tracks at MP 6.3 and home signals at Swift. When route at Swift is lined for diverging movement to NJT Kearny Connection from No. 2 track to No. 6 track or from No. 3 track to No. 5 track, directional indicator arrows will display at **both** Swift and MP 6.3.

When route at Swift is lined for diverging movement to NJT Kearny Connection from No. 2 track to No. 5 track or from No. 3 track to No. 6 track, directional indicator arrow will display at Swift, but will **not** display at MP 6.3.

Trains receiving route indication not proper for train's destination must stop east of Swift Interlocking and contact the Section A Dispatcher for instructions.

277-N4. BERGEN TO "A": CAB SIGNAL CODE CHANGE POINT SIGNS

Black signs with white, reflectorized numbers and letters are installed in the North River Tunnels at cab signal code change points, which are locations where cab signals can change for following movements. These signs will show the track number, followed by the letter "W", followed by the mile post location, e.g., "3W15." The purpose of these signs is to assist employees in reporting the location of any cab signal problems that occur in the tunnels, and to serve as MP locations for use in Form D's and TSRB's.

277-N5. NON-CONFORMING ASPECT: CP-MID

Signal aspect not in conformity with typical aspects in service at CP-Mid, governing eastward movements on Nos. 2 and 3 tracks.

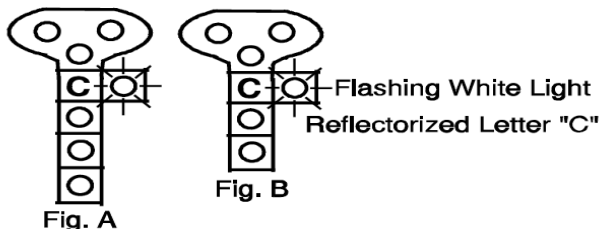

NAME: Clear to Next Interlocking

INDICATION: As shown in NORAC Rule 280a

277-N6. NON-CONFORMING ASPECT: HUNTER

A white directional indicator arrow is in service on Hunter's westward home signals on Nos. 3 & 4 tracks. The directional indicator arrow is displayed when a signal is cleared for a route from No. 3 or No. 4 track to Lehigh Line Connection No. 6 or No. 7 tracks. Trains receiving route indication not proper for train's destination must stop east of Hunter Interlocking and contact the Section "B" Train Dispatcher for instructions.

277-N7. SHORE

Home signal governing westward movement on No. 1 track at Shore is located to the left of No. 1 track.

298-N1. DISTANT SIGNAL MARKERS

The indication of Rule 298, "Distant Signal Marker," is changed as follows:

"When used in or approaching ABS territory without fixed signals (Rule 562 territory), this sign is a visual reminder to trains with inoperative cab signals or speed control that the requirements of Rule 562(c) or (d) apply at the next interlocking or controlled point signal.

When used in ABS territory without cab signals, this sign is a visual reminder to push-pull trains that Rule 504(b) applies in the block governed by the signal it is attached to."

Distant Signal Markers (Rule 298) are attached to the eastbound home signal at Rea on No. 1 track, the signal bridge east of Harrison Station (automatic signal bridge 80) on No. 2 and No. 3 tracks, and 4450 feet west of CP-Mid.

562-N1. PENN STATION: WESTBOUND TRAINS WITH INOPERATIVE CAB SIGNALS

Westbound trains in Penn Station, NY, that have experienced an en route cab signal failure and are destined to operate in the Rule 562 territory between "A" and Bergen, must not depart Penn Station without verbal permission of the Dispatcher to operate at Restricted Speed between "A" and Bergen, or Form D line 13 authorizing Rule 563.

562-N2. "NO FIXED ABS" SIGNS AT ENTRANCE TO RULE 562 TERRITORY

A white sign with a *RED CIRCLE AND A RED DIAGONAL LINE* across black letters "FIXED ABS" are located as follows to remind employees that they are entering Rule 562 territory, where cab signals are used *WITHOUT* fixed automatic block signals:

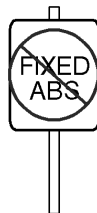

- Attached to the eastbound home signals at Rea on No. 2 and No. 3 tracks
- Attached to the eastbound home signal to Hudson on No. 1 track
- Attached to the westbound interlocking signals leaving "A" Interlocking (10th Avenue signal bridge),
- Attached to the overhead bridge at County between the westbound home signals for Tracks 1 & 2, and 3 & 4
- Attached to the overhead bridge at Midway between the eastbound home signals for Tracks 1 & 2, and 3 & 4
- On the ground at Midway Int. westbound home signals for Tracks 1, 2, 3, & 4
- At the eastbound home signals for tracks 2 and 3 at CP Clark
- On the ground at Ham Int. eastbound home signals for tracks 1 & 4

562-N3. BRAKING IN RULE 562 TERRITORY

Trains operating in territory where Rule 562 is in effect **must make a full service application** when reducing speed to comply with a change in cab signal indication. The locomotive quick release feature **must not be used**. EXCEPTION: Mixed consist trains may use the quick release feature when making an initial reduction **only**. When it is ascertained that the required speed will be effected, a lesser degree of braking may be used.

580-N1. ACSES RULES IN EFFECT FOR ALL AMTRAK TRAINS

ACSES Rules 580 through 591 and all ACSES related Special Instructions are in effect on main tracks and controlled sidings between the west limits of "A" Interlocking and the west limits of Girard Interlocking for all Amtrak trains.

At "A" Interlocking positive stop will be enforced eastbound only.

Positive stop will not be enforced entering ACSES limits eastbound at Girard Interlocking, or leaving ACSES limits southbound at Penn Interlocking or westbound at Zoo.

1. The controlling engine of **all Amtrak trains** operating in this territory must be equipped with on-board ACSES apparatus that is cut in and operative, except when failure occurs en route, or when hauled by an engine exempted in Special Instruction 580-S2.
2. **Non-Amtrak Trains:** Trains operated by railroads other than Amtrak are not required to be equipped with ACSES apparatus while operating in this territory.

583-N1. ACSES POSITIVE STOP: RADIO RELEASE

ACSES Positive Train Stop (PTS) radio release is in service for all interlocking signals located within or adjacent to ACSES equipped territory.

Exception: Data radio release is not in service at Dock Interlocking. Refer to SI 580-S1, Rule 583 for instructions regarding ACSES operation where data radios are not in service.

NOTE:

- ACSES will enforce a positive stop at interlocking signals whenever conditions result in the display of a Restricting cab signal aspect prior to arriving at the interlocking signal. Use of the Stop Release Button is governed by SI 580-S1, ACSES Rule 583.d, page 324.
- "NO TSR RESPONSE MPxxx.x" text message as described in SGRFN 48, along with the flashing "- -" symbol will display and the No Valid TSR Data light will be illuminated. Until Data radios are put in service this message need NOT be reported to the train dispatcher.

585-N1. ACSES OPERATION WITH FAILED CAB SIGNALS

Until Data Radios are in service at Dock Interlocking, trains operating with failed cab signals must NOT cut out the on-board ACSES, and will receive a penalty application approaching the Dock interlocking signals regardless of signal displayed.

606-N1. RUSTY RAILS, STATE OF NEW JERSEY

Sections of track within interlockings with track circuits which may not shunt due to rusted rail are indicated by yellow reflectorized markers displaying a black letter "R". These markers are located at the side of the track adjacent to the switch or the signal governing the route which may not shunt.

A member of the crew which has switching to perform within an interlocking must, before entering the interlocking, communicate with the Operator and inform him of the movements to be made and request information as to the existence of rusted rail or other abnormal conditions affecting such movements. The Operator must furnish to the crew member information as to such locations which may not shunt and require that a member of the crew report to him when the movement is completed. A movement is completed when it is beyond the opposing home signal.

When a train other than a through movement is routed to clear a main track over a power-operated switch within an interlocking, and such movement is to be made over a rusted rail or other abnormal rail condition which is indicated by a reflectorized marker, a member of the crew must report the train movement completed to the Operator. If such condition is not indicated by a reflectorized marker, the Operator must, before permitting such movement to be made, inform a member of the train crew of such condition and require that a report be made to him when the movement is completed.

Train crews on through movements on main tracks within an interlocking are not required to report the movement completed unless such a report is requested by the Operator.

These instructions do not apply to train or engine crews of trains making normal station stops within interlockings or to work trains or other equipment engaged in maintenance work on track which they have been given the exclusive right to use.

Instruction 11, AMT-4, "Special Instructions Governing Operation of Signals and Interlockings," is amended: (a) to require the installation of reflectorized markers indicating sections of track within interlockings with track circuits which may not shunt due to rusted rail; and (b) to eliminate reliance by the Operator on his visual observation to determine that the movement is completed.

706-N1. NORTH RIVER TUNNELS

"NYP Road Rptr" channel is in service for portable radios within the North River, East River and Empire Tunnels. Lower powered portable radio transmissions made on "NYP Road Rptr" within the tunnels are picked up by a repeater and retransmitted on Road Channel 060 at high enough power to be received by portable and/or engine radios also located within the tunnels. While the "NYP Road Rptr" channel transmits on the repeater frequency, it receives on Road Channel 060.

Note: No adjustment is necessary for engine radios to communicate with portable radios while within the tunnels. The Dispatcher at PSCC receives all transmissions made within the tunnels on Road Channel 060 or "NYP Road Rptr".

707-N1. EMERGENCY RADIO TRANSMISSIONS IN THE VICINITY OF MP 76 (DIVISION POST)

Road radio channel 060-060 is in service east of MP 76 (Division Post), and road radio channel 054-054 is in service west of MP 76. In the application of Rules 131, 132 & 136, whenever an emergency radio transmission must be initiated by an employee who is located within two miles of MP 76, the employee must first transmit on the radio channel in service on the territory where they are located. As soon as practical after the initial transmission, the employee must change to the other road radio channel and transmit a duplicate emergency message.

This instruction applies, for example, to an employee on a moving train that experiences an emergency application of the brakes when within two miles of MP 76 (Rule 136). It also applies to a track foreman or track inspector who observes or discovers an unsafe condition within two miles of MP 76, that would interfere with the safe passage of trains (Rules 131, 132).

900-N1. DISPATCHERS: ASSIGNED TERRITORIES

NEW YORK DISPATCHING OFFICE	
DISPATCHER	TERRITORY
PSCC	A (inclusive) to Bergen (inclusive).
Section A	Bergen (exclusive) to Hudson (exclusive).
Section B	Hudson (inclusive) to Hunter (inclusive).
CETC-9	Hunter (exclusive) to Roads (inclusive).
CETC-8	Roads (exclusive) to Ham (exclusive).
CETC-7	Ham (inclusive) to Holmes (exclusive).
WILMINGTON DISPATCHING OFFICE	
DISPATCHER	TERRITORY
CETC-6	Holmes (inclusive) to Girard (inclusive).

950-N1. STATE OF NEW JERSEY

An Engineer who has not made a trip in Road Service, as such, within a period of 12 months over the portion of railroad on which he is expected to operate within the State of New Jersey must not be used on such portion of the road until he has been re-examined and qualified by the proper officer.

If absent from all railroad duty for **30** days or more Engineers, Conductors and Assistant Conductors reporting to operate a train in road service in or through the State of New Jersey must notify the Dispatcher's Office or Operating Practices Department of such absence. The Dispatcher or Operating Practices Department supervisor will examine the employee so reporting to ascertain the employee's knowledge and understanding of any General Orders, Bulletin Orders or changes in the Operating Rules which may have been issued during his absence. The result of this examination will be shown on the prescribed form which will also show the signature of both the employee and the supervisor, and will be forwarded to the General Manager.

MAIN LINE-PHILADELPHIA TO WASHINGTON (PW)

STATIONS	MP	INT	PS	NOTES
ZOO (ML-Philadelphia to Harrisburg) (36th St. Connection) (Main Line-SEPTA)	0.0	1
PENN (36th St. Connection, Penn Coach Yard, Race St. Eng. House, No. 5 & No. 11 Running Trks)	1.5	X	...	2, 3, 16, 19
30th St-PHILADELPHIA (Lower Level)	1.5	...	X	...
ARSENAL (SEPTA) R-Broad(SEPTA)	2.7	X	...	4
PHIL R-CETC-4 TD	3.6	X
DARBY	6.1	...	X	...
CURTIS PARK	6.8	...	X	...
SHARON HILL	7.2	...	X	...
FOLCROFT	7.7	...	X	...
GLENOLDEN	8.3	...	X	...
NORWOOD	9.0	...	X	...
PROSPECT PARK / MOORE	9.5	...	X	...
RIDLEY PARK	10.4	...	X	...
CRUM LYNNE	11.2	...	X	...
BALDWIN R-CETC 4 TD	11.7	X
EDDYSTONE	12.3	...	X	...
CHESTER	13.4	...	X	...
LAMOKIN ST	14.4
HIGHLAND AVE	15.5	...	X	...
HOOK R-CETC-4 TD	16.8	X
MARCUS HOOK	17.1	...	X	...
STATE LINE (Pennsylvania-Delaware)	18.2
CLAYMONT	19.6	...	X	...
HOLLY R-CETC-4 TD	20.3	X
BELL (Northbound Yard Lead Trk., NS) R-CETC-4 TD	22.5	X	...	5
LANDLITH (No. 0 & South Wye Running) R-CETC-4 TD	25.4	X	...	6, 7, 17
WINE R-CETC-4 TD	26.6	X
WILMINGTON	26.8	...	X	...
BRANDY R-CETC-4 TD	26.9	X	...	8
YARD R-CETC-4 TD	28.2	X	...	8
RAGAN (Newcastle Sec. Trk., NS) R-CETC-3 TD	29.7	X	...	18
CHURCHMAN'S CROSSING	34.3	...	X	...
RUTHBY R-CETC-3 TD	36.5	X	...	9, 18
DAVIS (Reybold Branch, NS) R-CETC-3 TD	38.4	X
NEWARK	38.9	...	X	...

MAIN LINE-PHILADELPHIA TO WASHINGTON (PW)

STATIONS	MP	INT	PS	NOTES
STATE LINE (Delaware-Maryland)	41.4
IRON R-CETC-3 TD	41.5	X	...	9, 18
ELKTON	44.9
BACON R-CETC-3 TD	51.0	X	...	18
PRINCE R-CETC-3 TD	57.3	X	...	18
PERRYVILLE	59.4	...	X	...
PERRY R-CETC-3 TD (Port Road Branch, NS)	59.5	X
SUSQUEHANNA RIVER MOVABLE BRIDGE	60.2
GRACE R-CETC-3 TD	61.5	X	...	10, 18
OAK R-CETC-3 TD	62.9	X
ABERDEEN	65.5	...	X	...
BUSH R-CETC-3 TD (Movable Bridge)	71.6	X	...	11, 18
EDGEWOOD	75.1	...	X	...
WOOD R-CETC-3 TD (Edgewood & Magnolia Sidings)	75.3	X	...	12
MAGNOLIA R-CETC-3 TD (Edgewood & Magnolia Sidings)	76.9	X	...	12
GUNPOW R-CETC-2 TD	79.3	X	...	18
MARTIN	84.0	...	X	...
RIVER R-CETC-2 TD	89.3	X
POINT R-CETC-2 TD	90.1	X	...	13
BAY R-CETC-2 TD	91.9	X	...	9
BIDDLE R-CETC-2 TD	94.3	X
PAUL R-CETC-2 TD	95.2	X
BALTIMORE	95.7	...	X	...
CHARLES R-CETC-2 TD	95.9	X
JOHN ST. (Opening-B&P Tunnel)	96.2
PENNSYLVANIA AVE. (Opening-B&P Tunnel)	97.0
GILMORE ST. (South Portal-B&P Tunnel)	97.5
FULTON R-CETC-1 TD	97.7	X
BRIDGE R-CETC-1 TD	98.2	X
WEST BALTIMORE	98.5	...	X	15
FREDERICK ROAD	99.9
HALETHORPE	103.0	...	X	15
WINANS R-CETC-1 TD	103.4	X	...	9
B.W.I.	106.3	...	X	...
GROVE R-CETC-1 TD	112.4	X	...	18
ODENTON	113.6	...	X	...
BOWIE STATE	119.4	...	X	...
BOWIE R-CETC-1 TD (Pope's Creek Sec. Trk., CSX)	120.5	X	...	18
SEABROOK	124.7	...	X	...

MAIN LINE-PHILADELPHIA TO WASHINGTON (PW)

STATIONS	MP	INT	PS	NOTES
CARROLL R-CETC-1 TD	127.0	X	...	18
NEW CARROLLTON	127.0	...	X	...
LANDOVER R-CETC-1 TD (Landover Line, CSX)	128.8	X
STATE LINE (Maryland-D.C.)	131.6
CP AVENUE R-CETC-1 TD (Washington Terminal)	134.6	14

The direction from Zoo to CP Avenue is Southward.

Note 1: In service as an Int Station for PH Line & 36 Street Connection only, with Amtrak Road Radio Channel 054-054 and Conrail Road Radio Channel 046-046.

Note 2: No. 5 Running Track controlled by CETC 5 TD.

Note 3: No. 11 Running Track within Penn Interlocking controlled by CETC 5 TD.

Note 4: Int Rules do not apply on Amtrak Tracks No. 2 & 3.

Note 5: Int Rules apply on Tracks No. 1F & 2F.

Note 6: No. 0 Running Trk between Landlith & MP 24 (Edgemoor) controlled by CETC-4 TD.

Note 7: South Wye Running Track between Landlith & North Switch, Wreck Train Track controlled by CETC-4 TD.

Note 8: Int Rules apply on Tracks No. 1 & 2 only.

Note 9: Int Rules apply on Tracks A & No. 1 only.

Note 10: No. 4 track begins at north end of No. 33 sw (southward facing point switch south of southward Home Signal)

Note 11: No. 4 track ends at the southern limits of Bush Int. No. 3 trk ends at the south end of No. 23 turnout switch.

Note 12: Edgewood CS located on the west side of No. 3 track. Magnolia CS located on the east side of No. 2 track.

Note 13: Int Rules apply on Tracks No. 1, 2 & 3 only.

Note 14: Northward controlled signals.

Note 15: Rule 121(c) applies on Track A.

Note 16: Trks Spur, Pit, 1-4 Race & Race St. Eng. House Territory controlled by the Engine House Foreman. Authority must be obtained from Engine House Foreman to occupy these tracks. Trks 28-36 Penn Coach Yard designated Car Shop Repair tracks. All other Penn Coach Yard trks are designated yard tracks. Any unusual conditions, such as dewaterment, derailment, track conditions etc. must be reported to Engine House Foreman (AAR 054-054) or ATS 728-2181/82, Bell 215-349-2181/82.

Note 17: Trains clearing at north leg of the Wye Monday - Friday, 6am - 10pm must obtain permission of the Wilmington Back Shop Foreman (ATS: 736-6430; Commercial: 302-429-6430). All telephone communications must comply with NORAC Rule 716 and the special instructions governing the use of electronic devices. During all other times, a qualified employee must ensure the portion of the track to be used is clear before occupying it. Equipment must not be left unattended where it will foul the Back Shop Lead Track. Standing equipment must not foul the road crossing.

Note 18: Equipped with movable point frogs. See SI 80-S1.

Note 19: Equipped with slip switches. See SI 80-S1.

240-P1. SIGNAL RULES and CURRENT OF TRAFFIC.

261: On trks where Rule 261 is in effect, ABS Rules & CSS Rules 550–561 are in effect for movements in both directions.

Int: indicates interlocking rules in effect.

ACES Rules: See SI 580-P1.

Locations	Tracks from West to East					Notes
	4	3	2	1	Other	
Girard & Penn	Int	Int	...	2
Penn Int:	1
N3 Route	3
Within 30th St Station: Station trks 3, 4, 5 & 6	4
30th St Station & South End Penn	5, 6
Penn & Phil	...	261	261
CP Arsenal & Phil	261	10
No. 5 Track	261	...
Phil & Holly	261	261	261	261
Holly & Wine	...	261	261
Holly & Bell: No. 1F & No. 2F trks	261	13
Bell & Landlith	261
Wine & Ragan	...	261	11
Wine & Brandy	Int	Int	...	9,11
Brandy & Yard	261	261
Yard & Ragan	261
Ragan & Bacon	...	261	261	261	...	12
Ruthby & Iron: Track A	261	...
Bacon & Prince	...	261	261
Prince & Perry	261	261	261	261
Perry & Grace	...	261	261
Grace & Bush	261	261	261
Bush & Wood	...	261	261
Wood & Magnolia	...	261	261
Edgewood Siding	261	7
Magnolia Siding	261	8
Magnolia & Gunpow	...	261	261
Gunpow & Biddle	...	261	261	261
Track A	261	...
Biddle & Paul	...	Int	Int	Int	...	9
Paul & Charles	Int	Int	...	Int	...	9
Track No. 5	Int	15
Tracks No. 6, 7 & F	Int	9
Charles & Fulton	...	261	261
Fulton & Bridge	...	261	261
Bridge & Winans	...	261	261	261
Track A	261	...

240-P1. (Cont'd)

Locations	Tracks from West to East					Notes
	4	3	2	1	Other	
Winans & Landover	...	261	261	261	...	14
Landover & CP Avenue	...	261	261

Note 1: Within 30th St Station, Tracks No. 1 through 10 are designated Main Tracks.
Note 2: CSS Rules in effect on Nos. 1 & 4 tracks ("River Line") in both directions.
Note 3: CSS Rules in effect on N3 route for movements in both directions.
Note 4: CSS Rules in effect on No. 3 & 4 Station Tracks for Northward movements. CSS Rules in effect on No. 5 & 6 Station Tracks for Southward movements.
Note 5: CSS Rules in effect for movements in both directions on No. 4 track.
Note 6: CSS Rules in effect for northward movements on No. 1 track.
Note 7: Magnolia Siding located to the East of No. 2 track.
Note 8: Edgewood Siding located to the West of No. 3 track.
Note 9: CSS Rules in effect for movements in both directions.
Note 10: Within Phil Int tracks are designated as follows: No. 1 Arsenal Connection, No. 1, No. 2, No. 3, No. 4 & No. 5.
Note 11: Within Wilmington Station, Tracks are designated as follows: No. 1, No. 2, & No. 3 Tracks.
Note 12: Within Ragan Int, No. 1 Track extends to the Northward limits.
Note 13: Within Bell Int, No. 2F Trk extends to the South limits.
Note 14: Within Landover Int, No. 1 Track extends to the South limits.
Note 15: CSS Rules not in effect.

37-P1. PASSENGER TRAINS and FREIGHT TRAINS MAXIMUM SPEEDS and SPEED RESTRICTIONS, UNLESS OTHERWISE RESTRICTED

Locations and speeds shown in normal type are maximum authorized speeds. Locations and speeds shown in **bold type** are speed restrictions. *Maximum equipment speeds listed in SI 37-S5 (pgs 289-304) must not be exceeded.*

Where speeds change at an interlocking and the specific point where the speed change occurs is not specified, the lower speed will apply through the entire interlocking.

Where two speeds are separated by a diagonal line, the lower speed applies to trains not equipped with operative ACSES.

PASSENGER TRAIN TYPE "A" & "B" SPEEDS

Train Type A refers to High Speed Trainsets (HST) with tilt system *active*.

Train Type B refers to (1) HST's with tilt system *disabled*; and (2) trains consisting *exclusively* of HHP-8, AEM-7, ACS-64, P40BH, P42BH, P32AC-DM, or P32-BWH engines, and Amfleet, Horizon, Capitoliner Control Cars, LDSL Baggage Cars 61000-61084, MARC III control/coach cars, or US DOT test car DOTX 216.

Between/At	Train Type "A"				Train Type "B"			
	Track Nos.				Track Nos.			
	4	3	2	1	4	3	2	1
Zoo Int Station & Penn Int Signal located 1035 feet South of Spring Garden St OH Br.	60	60	60	60
Cvs between Zoo Int. Sta. & 34th St OH Br	30	30	30	30
Cvs 34th St OH Br & Penn Int Signal located 1035 feet south of Spring Garden St OH Br	50	50	40	40
Penn Int Signal located 1035 feet south of Spring Garden St OH Br & Penn Int signal located 100 feet south of Walnut St. OH Br:								
All tracks								30 MPH
Except: No. 3 Station Track, 30 th St. Station, between south end of station platform & southern limits station overbuild								25 MPH

37-P1. (Cont'd)

PASSENGER TRAIN TYPE "A" & "B" SPEEDS

Between/At	Train Type "A"				Train Type "B"			
	Track Nos.				Track Nos.			
	4	3	2	1	4	3	2	1
Penn Int signal located 100 feet south of Walnut St OH Br & South limits Penn Int	45	45	30	30
South limits Penn Int & Sig. Br 20-21	...	60	60	60	60	...
Signal Br 20-21 & MP 3	...	80	80	70	70	...
Arsenal & MP 3	45	45
No. 5 Track	45 MPH							
MP 3 & Phil	60	110	110	...	60	110	110	...
No. 5 Track	60 MPH							
Phil & Baldwin	90	110	110	90	90	110	110	90
Cvs MP 5 & Sharon Hill	70	105	105	70	70	90	90	70
Hook Int	...	100	100	100	100	...
Hook & Holly	110	125	125	105	110	110	110	105
UG Br MP 18.51	90	90
Holly Int	45	45	45	45
Holly & Bell	...	125	125	110	110	...
Nos. 1F & 2F trks	60 MPH							
Reverse Cvs under Jumpover north of Bell:								
Nos. 1F & 2F Trks	30 MPH							
Bell Int:								
Nos. 1F & 2F Trks	15 MPH							
Bell & Landlith	...	125	125	60	...	110	110	60
First Cv south of Bell	...	110	110	95	95	...
Landlith & Wine	...	80	80	80	80	...
Landlith Int:								
Diverging to or from No. 0 trk	5 MPH							
Cv north of Wilmington	...	50	50	45	40	...
Wine & Brandy	35	30	30	30
Wine & MP 27.1	...	35	30
Brandy & Yard	90	80	90	80
MP 27.1 & MP 28.3	...	90	90
Cv MP 27	...	50	40	50	...	45	40	40
Yard & Ragan	...	125	125	120	120	...
Ragan & Bacon	...	135	135	110	...	135	135	110
Cvs MP 30 & MP 31	...	130	130	110	110	...
Cv north of MP 33	...	130	130	110	110	...
Cvs MP 33 & MP 35	...	130	130	130	130	...
Ruthby & Davis: Track A	80 MPH							
Davis Int: Track A	30 MPH							
Davis & Iron: Track A	30 MPH							
Cv south of Davis	...	130	130	130	130	...
Cv at Iron	...	130	130	130	130	...
Cv north of Elkton	...	130	130	130	130	...

37-P1. (Cont'd)

PASSENGER TRAIN TYPE "A" & "B" SPEEDS

Between/At	Train Type "A"				Train Type "B"			
	Track Nos.				Track Nos.			
	4	3	2	1	4	3	2	1
Cv south of Elkton	...	130	130	130	130	...
Cv MP 47	...	130	130	115	115	...
Cv MP 49	...	130	130	110	110	...
Cv MP 50	...	110	110	90	...	90	90	90
Bacon Int.	...	130	125	130	125	...
Bacon & Prince	...	130	130	130	130	...
Cvs MP 53 & 1000 ft. south of MP 54	...	125	125	105	110	...
Cv MP 57	...	115	115	95	95	...
Prince & north limits Perry Int	60	115	115	60	60	110	110	60
Perry Int	60	110	110	60	60	110	110	60
Perry: North & south legs of wye								15 MPH
South limits Perry Int & south end of Susquehanna River Br	...	90	90	90	90	...
South end of Susquehanna River Br & north limits Grace Int * When not equipped with operative ACSES	...	125	125	125/ 110*	125/ 110*	...
First Cv north of Grace	...	115	95	95	...
Grace Int * When not equipped with operative ACSES	125	125	125	...	125/ 110*	125/ 110*	125/ 110*	...
South limits Grace Int & South limits Oak	125	90	125	...	125	90	125	...
South limits Oak Int & North limits Bush	125	110	125	...	125	110	125	...
First Cv north of Aberdeen	110	100	110
Cv north of Bush	120
Bush Int.	125	125	125	...	125	125	125	...
Bush & Gunpow	...	125	125	125	125	...
First Cv north of Gunpow	...	120	120	110	110	...
Wood & Magnolia: Magnolia Siding								30 MPH
Edgewood Siding								30 MPH
Gunpow & Sig. Br. 877-876	...	125	125	110	...	125	125	110
Gunpow & River: Track A								60 MPH
Cvs MP 85 & Sig. Br. 877-876	110	110	...
Sig. Br. 877-876 & River	...	125	125	110	...	110	110	110
River & Point	...	110	110	110	...	110	110	110
River & Bay: Track A								15 MPH
Point & Bay	...	110	110	100	...	100	105	100
Bay & north portals Union Tunnels	...	60	60	60	...	60	60	60
Reverse Cvs at Bay	50	50
Bay & Biddle: Track A								35 MPH
Cv MP 94	...	50	50	45	...	50	50	45
First Cv north of Union Tunnels	...	45	45	45	...	45	45	45
Through Union Tunnels	...	45	45	45	...	45	45	45

37-P1. (Cont'd)

PASSENGER TRAIN TYPE "A" & "B" SPEEDS

Between/At	Train Type "A"				Train Type "B"			
	Track Nos.				Track Nos.			
	4	3	2	1	4	3	2	1
South portals Union Tunnels & South limits Paul Int:								
All Routes to/from:								
Nos. 6 & 7 trks								30 MPH
Nos. 1, 3, 4 & F trks								15 MPH
South limits Paul Int & Charles:								
Nos. 3, 4, 6, & 7 trks								30 MPH
Nos. 1, 5 & F trks								15 MPH
South limits Charles Int & Fulton	...	30	30	30	30	...
Fulton & Bridge	...	80	80	80	80	...
Cv at Fulton	...	45	45	40	40	...
Bridge & MP 100	...	110	110	75	...	110	110	75
Track A								60 MPH
First Cv south of Bridge	...	55	55	50	...	50	50	50
Track A								30 MPH
First Cv north of Frederick Road	...	90	90	70	...	80	80	70
Track A								55 MPH
First Cv south of Frederick Road	...	105	105	100	100	...
MP 100 & Winans	...	125	125	110	...	110	110	110
Track A								60 MPH
First Cv South of MP 101	...	120	120	105	...	105	105	105
Winans & MP 107	...	120	125	110	...	110	110	110
Cv at Winans	100	100	100
MP 105 & Sig Br 1055-1054	...	90	90
First Cv South of MP 106	...	110	110	90	...	90	90	90
MP 107 & MP 125	...	125	125	110	...	125	125	110
Cvs MP 110 & Grove	120	120	...
Cvs MP 113 & MP 118	120	120	...
Cvs MP 113 & MP 114.3	95	95
Cvs MP 115 & MP 116.5	105	105
Cv at MP 117	95	95
First Cv South of MP 118	120	120	...
Cvs MP 119 & MP 120.3	105	105
First Cv South of MP 120	105	...	115	115	105
MP 125 & Carroll	...	125	125	110	...	110	110	110
First Cv South of MP 125	105	105
Cv at MP 126	105	105
Carroll & Landover	...	125	125	50	...	110	110	50
Cv at Landover	...	100	100	100	100	...
Landover Int	...	110	110	110	110	...
Landover & MP 133	...	125	125	125	125	...
MP 133 & CP Avenue	...	95	95	95	95	...

37-P1. (Cont'd)

PASSENGER TRAIN TYPE "C" & "D" SPEEDS

Train Type C refers to passenger trains that do not meet the criteria for train types A, B, or D.

Train Type D refers to passenger trains with mail, baggage or express cars in consist, that meet the Train Type D criteria defined in SI 37-S8, page 304.

NOTE 1: Train Type "D" trains must not exceed 60 MPH when operating with inoperative cab signals.

Between/At	Train Type "C"				Train Type "D"			
	Track Nos.				Track Nos.			
	4	3	2	1	4	3	2	1
Zoo Int Station & Penn Int Signal located 1035 feet South of Spring Garden St OH Br.	60	60	45	45
Cvs between Zoo Int. Sta. & 34th St OH Br	30	30	30	30
Cvs 34th St OH Br & Penn Int Signal located 1035 feet south of Spring Garden St OH Br	40	40	40	40
Penn Int Signal located 1035 feet south of Spring Garden St OH Br & south limits Penn Int: All tracks	30 MPH							
Except: No. 3 Station Track, 30 th St. Station, between south end of station platform & southern limits station overbuild	25 MPH							
Penn & Sig. Br 20-21	...	60	60	30	30	...
Cv South St OH Br & Signal Br 20-21	...	50	50
Signal Br 20-21 & MP 3	...	70	70	60	60	...
Arsenal & MP 3	45	30
No. 5 Track	45 MPH				30 MPH			
MP 3 & Phil	60	100	100	...	45	60	60	...
No. 5 Track	60 MPH							
Phil & Baldwin	90	100	100	90	80	80	80	80
Cvs MP 5 & Sharon Hill	70	90	90	70	70	70
Baldwin & Hook	90	90	90	90	80	90	90	80
Hook & Holly	110	110	110	105	70	70	70	70
UG Br MP 18.51	90
Holly Int	45	45	45	45
Holly & Bell	...	110	110	90	90	...
Nos. 1F & 2F trks	60 MPH							
Reverse Cvs under Jumpover north of Bell:								
Nos. 1F & 2F Trks	30 MPH							
Bell Int:								
Nos. 1F & 2F Trks	15 MPH							
Bell & Landlith	...	105	105	60	...	80	80	60
First Cv south of Bell	...	90	90
Landlith & Wine	...	80	80	65	65	...
Landlith Int:								
Diverging to or from No. 0 trk	5 MPH							
Cv north of Wilmington	...	40	40	40	40	...

37-P1 (Cont'd)

PASSENGER TRAIN TYPE "C" & "D" SPEEDS

Between/At	Train Type "C"				Train Type "D"			
	Track Nos.				Track Nos.			
	4	3	2	1	4	3	2	1
Wine & Brandy	30	30	20	20
Wine & MP 27.1	...	30	20
Brandy & Yard	80	80	30	30
MP 27.1 & MP 28.3	...	80	30
Cv MP 27	...	40	40	40
Yard & Ragan	...	110	110	80	80	...
Ragan & Bacon	...	110	110	110	...	90	90	90
Ruthby & Davis: Track A	80 MPH				65 MPH			
Davis Int: Track A	30 MPH							
Davis & Iron: Track A	30 MPH							
Cv MP 50	...	90	90	90
Bacon & Prince	...	110	110	80	80	...
Cvs MP 53 & 1000 ft. south of MP 54	...	105
Cv MP 57	...	95	95
Prince & south limits Perry Int	60	110	110	60	50	90	80	60
Perry: North & south legs of wye	15 MPH							
South limits Perry Int & south end of Susquehanna River Br	...	90	90	90	90	...
South end of Susquehanna River Br & north limits Grace Int	...	110	110	90	90	...
First Cv north of Grace	...	95	90
Grace Int	110	110	110	...	90	90	90	...
South limits Grace Int & South limits Oak	110	80	110	...	90	80	90	...
South limits Oak Int & North limits Bush	110	100	110	...	90	80	90	...
Bush Int.	110	110	110	...	90	90	90	...
Bush & Gunpow	...	110	110	90	90	...
First Cv north of Gunpow	...	100	100
Wood & Magnolia: Magnolia Siding	30 MPH							
Edgewood Siding	30 MPH							
Gunpow & MP 85	...	110	110	110	...	90	90	90
Gunpow & River: Track A	60 MPH							
MP 85 & Point	...	110	110	110	...	90	90	90
River & Bay: Track A	15 MPH							
Point & Bay	...	100	105	100	...	90	60	60
Point & MP 91 (Southward only)	...	90	...	90
Bay & north portals Union Tunnels	...	60	60	60	...	55	55	50
Reverse Cvs at Bay	...	50	...	50	...	50
Bay & Biddle: Track A	35 MPH							
Cv MP 94	...	45	45	45	...	45	45	45
First Cv north of Union Tunnels	...	45	45	45	...	45	45	45

37-P1 (Cont'd)

PASSENGER TRAIN TYPE "C" & "D" SPEEDS

Between/At	Train Type "C"				Train Type "D"			
	Track Nos.				Track Nos.			
	4	3	2	1	4	3	2	1
Through Union Tunnels	...	45	45	45	...	30	30	30
South portals Union Tunnels & South limits Paul Int: All Routes to/from: Trks. 6 & 7 Trks. 1, 3, 4 & F	30 MPH 15 MPH				15 MPH 15 MPH			
South limits Paul Int & Charles: Trks. 3, 4, 6, & 7 Trks. 1, 5 & F	30 MPH 15 MPH				15 MPH 15 MPH			
South limits Charles Int & Fulton	...	30	30	20	20	...
Fulton & Bridge	...	75	75	35	35	...
Cv at Fulton	...	40	40
Bridge & MP 100	...	75	75	75	...	70	70	70
Track A	60 MPH							
First Cv south of Bridge	...	50	50	50	...	50	50	50
Track A	30 MPH							
First Cv north of Frederick Road	70	70
Track A	55 MPH							
MP 100 & MP 101	...	110	110	90	...	90	90	90
Track A	60 MPH							
First Cv south of Frederick Road	...	100	100
MP 101 & Winans	...	110	110	110	...	90	90	90
Track A	60 MPH							
First Cv South of MP 101	...	105	105	105
Winans & Carroll	...	110	110	110	...	90	90	90
Cv at Winans	...	100	100	100
MP 105 & Sig Br 1055-1054	...	90
First Cv South of MP 106	...	90	90	90
Cvs MP 113 & MP 114.3	85	85
Cvs MP 115 & MP 116.5	100
Cv at MP 117	90
Cvs MP 119 & MP 120.3	100
First Cv South of MP 125	100
Cv at MP 126	100
Carroll & Landover	...	110	110	50	...	90	80	50
Cv at Landover	...	100	100
Landover & MP 133	...	110	110	80	80	...
MP 133 & CP Avenue	...	85	85	70	70	...

37-P1. (Cont'd)

FREIGHT TRAIN TYPE "E" SPEEDS

NOTE: Where the symbol ▼ appears, freight trains equipped with LSL on leading engine must not exceed 10 MPH on all routes, Zoo Int Station to Signal Br 20-21.

Between/At	Train Type "E"			
	Track Nos.			
	No. 4	No. 3	No. 2	No. 1
Zoo Int Station & Penn Int. Signal located 1035 feet South of Spring Garden St OH Br.:				
Northward	▼ 20	▼ 20
Southward	▼ 30	▼ 25
Penn Int. Signal located 1035 feet south of Spring Garden St OH Br & south limits Penn Int., All Routes:				
Southward				▼ 25 MPH
Northward				▼ 20 MPH
<i>Except</i> Station Trks 2 & 3:				▼ 15 MPH
Penn & Signal Br 20-21:				
Northward	▼ 20	▼ 20	...
Southward	▼ 30	▼ 30	...
Signal Br 20-21 & Phil	...	50	50	...
Arsenal & Phil	25
No. 5 Track				25 MPH
Phil & Baldwin	50	50	40	40
Cvs MP 5 & Sharon Hill	30	30
Signal 95 & Moore	40
Baldwin & Hook	45	45	45	45
Hook & Holly	50	50	35	35
Holly Int	40
Holly & Bell	...	50	50	...
No. 1F & No. 2F trks				30 MPH
Bell Int: Nos. 1F & 2F trks				10 MPH
Bell & Landlith	...	30	30	40
Landlith Int:				
Diverging to or from No. 0 track				5 MPH
Landlith & Wine	...	25	25	...
Wine & Brandy	15	15
Wine & MP 27.1	...	15
Brandy & Yard	30	30
MP 27.1 & MP 28.3	...	30
Yard & Ragan	...	45	45	...
Ragan & Davis	...	50	50	50
Ragan & Davis: All tracks - Cars exceeding 263,000 Pounds				30 MPH
Davis & Iron	...	30	30	30
Ruthby & Davis: Track A				30 MPH
Davis & Iron: Track A				25 MPH
Iron & Bacon	...	40	40	40
Bacon & Prince	...	45	45	...
Prince & MP 58	40	50	50	40
MP 58 & south limits Perry Int	40	40	40	40
Perry: North & south legs of wye				10 MPH

37-P1. (Cont'd)

FREIGHT TRAIN TYPE "E" SPEEDS

Between/At	Train Type "E"			
	Track Nos.			
	No. 4	No. 3	No. 2	No. 1
South limits Perry Int & south end of Susquehanna River Br	30	30	...
South end of Susquehanna River Br & Grace	...	50	50	...
Grace & Oak	35	35	35	...
Oak & South Limits Bush	50	50	50	...
South Limits Bush & Gunpow	...	45	45	...
Wood & Magnolia:				
Magnolia Siding				25 MPH
Edgewood Siding				25 MPH
Gunpow & River	...	50	50	50
Track A				40 MPH
River & North Portals Union Tunnels	...	25	25	25
River & Bay: Track A				10 MPH
Bay & Biddle: Track A				20 MPH
Through Union Tunnels	...	30	30	30
South portals Union Tunnels & South limits Charles Int:				
All Tracks				10 MPH
South limits Charles Int & Fulton	...	20	20	...
Fulton & Bridge	...	25	25	...
Cv at Fulton	...	20	20	...
Bridge & MP 100	...	35	35	35
Track A				35 MPH
First Cv south of Bridge: Trk A				30 MPH
MP 100 & MP 101	...	45	45	45
Track A				40 MPH
MP 101 & Winans	...	50	50	50
Track A				40 MPH
Winans & Grove	...	50	50	50
Cvs MP 110 & Grove	...	40	40	...
Grove & MP 125	...	40	40	40
MP 125 & Carroll	...	50	50	50
Carroll & Landover	...	50	50	40
Landover & CP Avenue	...	50	50	...

C-P1. QUALIFICATION FOR YARD & WORK TRAIN SERVICE—CONDUCTORS & ASSISTANT CONDUCTORS

Conductors must be qualified on the required physical characteristics before accepting assignment as a yard or work train Conductor. Conductors and Assistant Conductors absent from yard service for 6 months or longer must contact a Terminal Trainmaster before starting a yard assignment at Washington or Philadelphia Terminal. Conductors and Assistant Conductors who have not worked a regular assigned work train position for 6 months or longer must contact a Trainmaster or Road Foreman before working a regular work train assignment.

F-P1. B. & P. TUNNEL

In the event of an accident or irregularity occurring to a train in the B. & P. or Union Tunnels which endangers the safety of passengers or train, immediate action must be taken to get passengers to a place of safety. If it can be safely done, trains should be moved out of the tunnel. If this is not practical, trains should proceed to the first tunnel exit.

When necessary to remove passengers from trains at tunnel exits, trainmen will exercise the greatest care for their protection.

In order to communicate effectively with Emergency Response Forces and thereby reduce response time, employees contacting the Emergency Response Forces must refer to the following railroad locations, and their corresponding street level access points. The access points are marked at street level with the identifying letters shown, to indicate where access to trains can be obtained from street level:

B&P Tunnel	Street Location	Access Point
Fulton Int	Monroe and Laurens Sts.	A
Gilmore St south portal, stairway at west side of portal	Gilmore and Winchester Sts.	B
Pennsylvania Ave opening, stairway on east wall, north end of opening	Pennsylvania Ave and Pitcher St	C
John St. opening, stairway on west side beyond west wall	Mount Royal and North Avenues	D
North portal	Falls Road and Lafayette Ave, under Howard St OH Br	E
Greenmount Ave south portal	400 block of Preston St.	F
Bond St. north portal	Broadway and East Hoffman St.	G

1-P1. MARC PENN LINE SERVICE T&E OPERATIONS NOTICES

Marc Penn Line Service T&E Operations Notices contain information and procedures related specifically to MARC service and will be issued as needed. They will be available at MARC sign-up locations at Baltimore, Martins and Washington.

MARC Penn Line Service T&E Operations Notices will be numbered sequentially, the number being prefixed by the last two digits of the calendar year. The number of the latest notice will be published in the Mid-Atlantic Bulletin Orders.

T&E crews assigned to work MARC assignments are required to review the information in the MARC Penn Line Service T&E Operations Notices and retain a copy while on duty.

1-P2. PENN COACH YARD: PENN COACH YARD BULLETIN (PCYB) / OPERATING INSTRUCTIONS - PENN COACH YARD

1. PCYB Instructions

The Penn Coach Yard Bulletin (PCYB) contains instructions for crews who will operate in Penn Coach Yard and Race Street Engine House. The PCYB will be issued as necessary, will be numbered consecutively, and will remain in effect until superseded by the next Yard Bulletin. The current Yard Bulletin will be posted at Race Street Engine House. Before operating in Penn Coach Yard, employees must familiarize themselves with the current Yard Bulletin and comply with its instructions. If no Yard Bulletin is posted, employees must contact a Trainmaster or Road Foreman for instructions.

The Senior Analyst Operating Practices will reissue the Yard Bulletin as necessary. When a new Yard Bulletin is issued, it must not be considered in effect until a Trainmaster or Road Foreman has posted the new Yard Bulletin, destroyed the previous one, and notified crews on duty and working in the yard of any changed instructions that are more restrictive than those published in the previous Yard Bulletin.

2. Operating Instructions - Penn Coach Yard

Crews of trains en route to Penn Coach yard from Zoo or Penn must not proceed beyond Nos. 1 or 2 Lead, the Car Wash on the Rundown Track, or north of the Junction Crossover between the MH and No. 37 Leads unless they have contacted the Race Street Engine

1-P2. (Cont'd)

House Foreman to receive specific movement instructions.

All crews must receive authority from the Race Street Engine House Foreman before operating on Engine Servicing Tracks 1 through 4 Race, Race Street Engine House Territory, the Spur, and the Pit Track.

All crews must contact the Race Street Engine Foreman before adding or removing equipment from PCY.

16-P1. BLUE SIGNAL PROTECTION: BALTIMORE

Fixed overhead beacon blue signal lights in service on both ends of the station platforms on Baltimore Station Tracks Nos. 4, 5, 6 and 7.

Illuminated blue signals signify that workmen are on, under, or between rolling equipment.

19-P1. BAY

Trains on Track Nos. A and 1 must blow one long sound on the engine horn when approaching Bay northward and Point southward.

19-P2. ENGINE WHISTLE OR HORN: 30th STREET STATION

Except when approaching Roadway Workers or in an emergency, trains must **not** sound their engine whistle or horn while within the confines of the 30th Street Station overbuild. This restriction is intended to prevent hearing loss injuries in passengers as well as employees working in the station.

19-P3. APPROACHING BWI & NEW CARROLLTON STATIONS: ENGINE WHISTLE OR HORN

Passenger trains not making a station stop at BWI or New Carrollton must sound one long blast on their engine whistle or horn when approaching these stations on a track adjacent to the high platform whenever passengers are observed.

20-P1. PENN COACH YARD-RACE ST. ENGINEHOUSE

The engine bell must be rung continuously during any movement in the yard or enginehouse territory. Engines not equipped are exempt.

20-P2. ENGINE BELL: 30th STREET STATION

Trains equipped with an engine bell must sound it continuously while moving within the confines of the 30th Street Station Overbuild.

34-P1. STATION STOP MARKERS

West Baltimore: When spotting a train on the station platform, Engineers must use Station Stop markers MARC 1, MARC 2 and MARC 3 as a guide. These markers are located on the east side of "A" Track north of the station. Conductors and Engineers must discuss which markers will be used during their daily job briefing.

34-P2. LANDOVER - RUNNING BRAKE TEST

Southward passenger trains not making a station stop at New Carrollton must make a running test of the brakes before passing Landover, as per instruction **P4.2.4** of **AMT-3** Air Brake and Train Handling Instructions.

34-P3. 30th STREET STATION

Due to insufficient ventilation, the following procedure will apply at 30th Street Station:

- ▶ Inbound trains with diesel engines and a dwell time of over 5 minutes must shut down HEP 5 minutes after arrival.
- ▶ Southbound trains must have HEP set up and operated from the lead locomotive. HEP must not be started until locomotives are clear of station overbuild. Throttle position must be limited to the 2nd notch departing Philadelphia, when practical.
- ▶ Keystone Service trains from New York destined for Harrisburg must spot trains so the outbound engine is outside of the station overbuild.
- ▶ Engines cut off inbound trains must pull down to the extreme end of the platform.
- ▶ New Jersey Transit trains: After discharging passengers, crews must re-spot equipment so the diesel engine is at the extreme end of the platform. Crews will re-spot equipment for loading and restart HEP 10 minutes before departure.

NOTE: Conductors may instruct Engineers to leave HEP on longer should conditions require.

34-P4. ENGINE CHANGES: TRAINS ORIGINATING OR TERMINATING IN PHILADELPHIA

Outbound crews for trains originating 30th St. Station, trains from Harrisburg en route to New York, or from New York en route to Harrisburg must call the Race Street Engine House Foreman (AAR 54-54) or ATS 728-2181/82, Bell 215-349-2181/82 for disposition of outbound train/ locomotive(s). If unable to contact Engine House Foreman, call CETC for assistance.

Inbound crews for trains terminating 30th St. Station, trains from Harrisburg en route to New York, or from New York en route to Harrisburg must contact the CETC 5 Dispatcher for disposition of inbound train/ locomotive(s) upon arrival.

35-P1. FREIGHT TRAIN CAR LIMIT

Perry to Landover: Freight trains consisting of 160 empty hopper cars are permitted between Perry and Landover. (Exception to SI 35-S4, page 282)

Davis to Bay: Under the following conditions (exception to SI 35-S4, page 282), freight trains consisting of 150 cars are permitted between Davis and Bay:

1. The train is equipped with operative telemetry devices or a caboose, and
2. The train does not contain intermodal cars, and
3. The train does not contain more than 65 consecutive TPIX (Tropicana) cars.

35-P2. WINANS-RIVER—STOPPING PROCEDURE

Between Winans and River interlockings, after coming to a complete stop, engineer must make a full service automatic brake application and leave it applied until train is ready to depart. Engineer must exercise caution when starting train to ensure that brakes are released and brake pipe pressure is being restored.

35-P3. FULTON-BIDDLE-BRAKING PROCEDURE

Due to the critical forces generated by excessive use of the dynamic or independent brake, Engineers operating freight trains between MP 94 and MP 97 **MUST** arrange to minimize head end forces by limiting the dynamic brake not to exceed one-half the indication of the dynamic brake meter or 350 dynamic brake AMPS, whichever is less. Freight trains operating without dynamic brake **MUST NOT** exceed one half the Maximum independent brake cylinder pressure allowed for the lead unit.

When necessary to control the speed of the train between MP 94 and MP 97, the automatic air brake **MUST** be used.

Note: This Special Instruction will not apply to trains consisting entirely of empty hopper cars.

35-P4. CHARLES-FULTON

Mineral Trains operated between Charles and Fulton must not exceed 10,600 tons and are limited to 80 cars.

35-P5. MINERAL FREIGHT TRAINS: PAUL-FULTON

Between the hours of 6:00 AM and 9:00 PM, mineral freight trains with head end power exceeding 18 traction motors must be assisted by a helper engine coupled to the rear of the train.

The number of traction motors operated on the head end must not exceed 24 at any time.

35-P6. BAY-LANDOVER

Mixed freight trains with TOFC and COFC Cars in consist operating between Bay and Landover must have TOFC and COFC Cars positioned on the rear third of the train. Where percentage of TOFC and COFC Cars exceeds one third of the train consist, TOFC and COFC Cars must be placed on the rear portion. Conductors of freight trains with TOFC and COFC Cars in consist must converse with the Dispatcher as to the make up of their train before entering this territory.

37-P2. SPEEDOMETER CHECKING: MEASURED MILES

The distance between the sets of Mile Posts listed below is a measured mile. White marker posts are installed on both sides of the tracks at locations marked with an asterisk(*).

MP 6- MP 7 ★MP 8- ★MP 9 ★MP 9- MP 10 MP 10- MP 11 MP 16- MP 17 ★MP 20- ★MP 21 ★MP 21- MP 22 MP 24- MP 25 ★MP 34- ★MP 35	MP 53- MP 54 MP 57- MP 58 MP 61- MP 62 MP 64- MP 65 MP 76- MP 77 MP 85- MP 86 MP 99- MP 100 MP 108- MP 109 MP 110- MP 111	MP 111- MP 112 MP 121- ★MP 122 ★MP 122- ★MP 123 MP 127- MP 128 MP 129- ★MP 130 ★MP 130- ★MP 131 ★MP 131- MP 132 MP 132- MP 133
---	---	---

37-P3. MAXIMUM SPEEDS, RUNNING TRACKS

Track	Between	And	Restricted Speed not exceeding
No. 11	North end Penn Int.	South end Penn Int.	10 MPH
No. 5	Penn	MP 1.9	10 MPH
No. 0	New Castle Secondary	Landlith	10 MPH

37-P4. MAXIMUM SPEEDS, OTHER TRACKS

Location	Track(s)	Restricted Speed not exceeding
Penn Coach Yard	All	5 MPH
Wilmington Shops	All	5 MPH
Martins MARC Facility	All	5 MPH
All Yard Tracks, Industrial Tracks and Public Delivery Tracks that are connected to an Amtrak Main or Running Track		10 MPH

37-P5. WRECK and WIRE TRAINS

Between:	Wire Train	Boom Trailing	Boom Forward
		Miles Per Hour	
		Wreck	Wreck
Mantua & Signal Br. 2.1	30	30	20
Signal Br. 2.1 & CP Avenue	50	40	30

Note: Where speed of freight trains is slower than the speeds shown in this instruction, the freight train speed must not be exceeded.

40-P1. ENGINE AND EQUIPMENT RESTRICTIONS

The numbers shown in the columns to the right of each listed location specify the maximum height of the engines and equipment that may be operated. Engine and equipment dimension specifications are assigned in S.I. 37-S5 (page 289) for equipment authorized to operate on the NEC.

Notes shown in parentheses in the location column are defined at the end of the table.

Location	Tracks					
	4	3	2	1	A	Other
Zoo & Signal Br 20-21	4	4
Via 2 & 3 Berry	...	5	5
30 th St. Station, all tracks (c)	4
Penn Coach Yard, all tracks:						
North of road crossing	5
South of road crossing	4
Signal Br 20-21 & Landlith	5	5	5	5
Landlith & Brandy	...	5	5	5
Tracks 1F & 2F Holly & Bell	5
Wilmington Station	...	5	4	5
Brandy & Yard	...	5	4	6
Yard & Ragan	...	5	6
Ragan & Bacon	...	6	6	7	7	...
Bacon & Prince	...	7	7
Prince & Perry	7	6	6	6
Perry & Grace	...	7	7
Grace & Bush	7	7	6
Bush & Gunpow	7	7	7	7
Gunpow & River	...	6	6	7	7	...
River & Bay	...	5	5	7	7	...
Bay & Charles	...	5	5	5	5	...
Baltimore Station:						
Tracks Nos. 3 to 7	4	4	4
Tracks Nos. 1 & F	5	...	5
Charles & Bridge (a)(b)	...	4	4
Bridge & Bowie	...	5	5	5	5	...
Bowie & Landover	...	5	5	6
Landover & CP Avenue	...	4	4

Notes:

- (a) Capitoline Control Car 9637 is prohibited from operating between Fulton and Paul.
- (b) See Note B in SI 37-S5, page 297.
- (c) American Crane A59019 may operate on No. 11 Running Track (also see SI 41-S12, page 307).

40-P2. EQUIPMENT RESTRICTIONS: PENN COACH YARD & RACE ST. ENGINE HOUSE TERRITORY

- ▶ High Speed Trainset (HST) equipment is prohibited from operating on any yard track south of the Penn Coach Yard Access Road Crossing.
- ▶ HST equipment may operate on 32 & 33 tracks from 2 Lead to the Penn Coach Yard Access Road Crossing.
- ▶ HST equipment may operate on 28 through 34 trks between 2 Lead and the Junction Switch under the supervision of a Track Supervisor.
- ▶ Express Reefer cars Series 74000 are prohibited from operating over the route between the MH Track & Trk Nos. 23, 25 & 26 (switches 4R26, 2625 & 2523).

41-P1. BALTIMORE STATION – NOS. 4 & 5 TRACKS

Due to close platform clearance, only equipment normally used in passenger service may operate on Nos. 4 & 5 tracks in Baltimore Station. EXCEPTION: In an emergency, non-passenger type equipment may operate on No. 4 track at 2 mph when authorized by the Dispatcher.

41-P2. LANDLITH – FREIGHT TRAIN MOVEMENTS

Freight trains with or without cars (except Amtrak work trains and maintenance equipment) are prohibited from making diverging moves onto or off of the “O” track at Landlith.

41-P3. CARS EXCEEDING 263,000 POUNDS

NS, CSX and Conrail trains containing cars with gross weight not exceeding 286,000 pounds may operate over the following line segments:

- ▶ Between Phil and Bell — All tracks.
- ▶ Between Ragan and Davis – All Tracks (Maximum Speed 30 MPH)
- ▶ Between Davis and Paul — All tracks.
- ▶ Between Paul and Charles — Tracks 1, 6, 7 & F only.
- ▶ Between Bowie and Landover — Tracks Nos. 1 and 2 only. (Cars operating on Track No. 3 are limited to 263,000 pounds, per SI 41-S2, page 305.)

41-P4. NS TRACK GEOMETRY CARS

Norfolk Southern Track Geometry Cars Nos. 31, 33⁽¹⁾, 34 and 48 are cars that must be pulled by an engine. Their maximum speed is 50 MPH. Because of clearance concerns, movement must be made at Restricted Speed while passing high-level station platforms, and immediately adjacent tracks must be kept clear of other movements. These cars may operate **only** on the following routes:

Location	Acceptable Routes
Perry-Prince	Trk 4
Prince-Bacon	Trks 2 & 3
Bacon-Ragan	Trks 1, 2, 3 & A

Note 1: Car No. 33 is prohibited from passing high level platforms, except for the mini high platform on No. 4 track at Thorndale, and the mini high platforms at Exton (PH Line).

45-P1. EXPLOSIVES PROHIBITED—30TH ST. STATION

Cars containing shipments of class A explosives, except laboratory samples, and all class B and C explosives in excess of 200 pounds, are prohibited under all overhead structures on all tracks, 30th St., Philadelphia, Lower Level.

45-P2. UNION TUNNELS/B & P TUNNELS

Other trains must not be permitted to enter Union Tunnels or B & P Tunnel while a train with placarded loaded cars containing hazardous materials is passing through the tunnels.

47-P1. PENN COACH YARD - SECTION BREAKS

Electric locomotives must not be left standing within limits of section breaks. Location of section breaks in Penn Coach Yard are identified by section break signs in the catenary. A yellow-gold sign with black letters “SB” identifies the location when *entering* a section break. A red sign with no lettering identifies the location when *leaving* a section break.

72-P1. TRAIN INSPECTION DETECTORS

Type of Detector	MP Location	Direction of Operation	Tracks(s)	Recorder Location	Notes
HBD	16.3	North & South	1,2,3 & 4	CETC 4	2
DED	33.9	North & South	1,2 & 3	CETC 3	...
HBD	34.9	North & South	1,2 & 3	CETC 3	2
HBD	52.4	North & South	2 & 3	CETC 3	2
HBD	67.4	North & South	2,3 & 4	CETC 3	2
Height	71.7	South	2 & 3	CETC 3	1
HBD	83.7	North & South	A,1,2 & 3	CETC 2	2
HBD	107.5	North & South	1, 2 & 3	CETC 1	2
HBD	123.3	North & South	1, 2 & 3	CETC 1	2

Note 1: Height detectors are set to alarm at height 16 feet 2½ inches and over. Non-passenger type trains that activate the high car alarm must not be permitted to operate south of Bay, unless authorized by the Assistant Superintendent Train Movement, or his representative. Passenger trains that activate the detector may be permitted to proceed to Baltimore where a visual inspection will be made.

Note 2: Equipped with **supplemental radio alarm** hot box detection apparatus, which will transmit **only** when a hot journal has been detected, as follows: Upon detection of first defect, system will transmit milepost location, track number & the message "Defect detected." When this message is received, the train must be stopped when rear end is clear of the detector. When entire train has passed the detector, a radio message will be transmitted stating the results of the inspection. After a one second delay, the message will be repeated. If a defect is detected, the train must be stopped and inspected in accordance with the instructions received, and the Dispatcher notified. Detector will identify suspected hot journals or dragging equipment by axle number counting from head end (including engines). If a defect is not found at the axle location specified, that entire car and the 2 cars immediately ahead and behind that car must be inspected. If the radio transmission reports 6 defects, which is the maximum number the detector can transmit, the entire train behind the 6th defect must be inspected.

72-P2. WHEEL IMPACT DETECTORS

Wheel impact detectors are installed at the following locations. See SI 72-S8.

MP	Location	Tracks
75	Edgewood	2, 3
16.2	Marcus Hook	1, 2, 3, 4

104-P1. NORMAL POSITION OF SWITCHES AND CROSSOVERS AT SPECIFIED LOCATIONS:

Switch location	Connecting	With	Normal Position is for Movement	Notes
Penn Coach Yard	Car Washing Trk	Run Down & Trk No. 37	Through on Car Washing Trk	...

104-P2. SWITCHES EQUIPPED WITH ELECTRIC LOCKS

The following hand-operated switches are equipped with an electric lock; permission to occupy Main Track, Interlocking or Controlled Siding must be obtained from the Dispatcher before lock is removed from keeper.

Locations	Switch	Controlled By	Notes
MP 12.1	No. 4 trk to Eddystone yard	...	1
MP 15.8	No. 1 trk to Naught trk	...	1
MP 19.4	No. 4 track to Citi Steel	...	1
MP 31.5	No. 3 trk to Crowell Corp.	...	1
MP 35.8	No. 3 trk to Harmony Ind. Park	...	1
MP 37.4	No. 3 trk to General Foods	...	1
MP 40.4	Trk A to No. 0 trk	...	1
MP 45.5	No. 1 trk to Red Mill Ind. Trk	...	1
MP 58.5	No. 1 trk to Perryville MW Base	...	1
MP 65.6	No. 2 trk to Ind. trk	...	1
MP 68.3	No. 4 trk to Channel Lumber	...	1
MP 75.8	Magnolia Siding to Arsenal Industrial trk.	...	1, 2
MP 80.9	Trk A to Chase Public Del. Trk	...	1 & 2
MP 81.9	Trk A to Baltimore Gas & Electric Co.	...	1
MP 83.5	Trk A to MARC Facility	...	1
MP 84.9	Trk A to Chesapeake Ind. Park
MP 90.9	No. 3 trk to Baltimore Steel Industrial trk.	...	1
MP 91.5	No. 3 trk to Kiekheffer Ind. trk.	...	1
MP 101.5	Trk A to Solo Cup Co.	...	1
MP 101.6	No. 3 trk to Filberts	...	1 & 4
MP 108.1	No. 3 trk to Baltimore Commons Industrial trk.	...	1
MP 111.9	No. 1 trk to McMillan-Blodel Co.	...	1
MP 113.5	No. 1 trk to National Plastics Co.	...	1
MP 113.9	No. 1 trk to North End MW Base	...	1
MP 114.9	No. 1 trk to South End MW Base	...	1 & 4
MP 122.4	No. 1 trk to Home Depot	...	1
MP 127.8	No. 1 trk to Ardwick Ind. Park	...	1

Note 1: To enter side track from Main Track, train must occupy track circuit which extends 50 feet from point of switch, before switch can be opened.

Note 2: Refer to SI 132-P1, Trks & Switches Out of Service.

Note 3: Switch & derail each equipped with electric lock; both switch & derail must be lined to normal position before inserting switch lock at switch or derail.

Note 4: Switch and derail each equipped with electric lock. Switch locks must be removed from both switch and derail before either is operated. After movement is completed, both switch and derail must be restored to normal position before inserting switch lock at switch or derail.

132-P1. TRACKS AND SWITCHES OUT OF SERVICE

The tracks and switches listed below are out of service for train movements, except when such movements are personally supervised by an MW Foreman or MW Supervisor, or when movement consists entirely of track cars.

If a remotely controlled switch provides access to an affected track, the Operator or Dispatcher must apply blocking device protection to prevent the accidental routing of trains to that track. If a hand operated switch provides access to an affected track, the last Engineering Department employee to use the switch must spike the switch to prevent its accidental use.

Location	Track/Switch
Hook	Plug Track
Davis	No. 5 yard trk
Wood	Station Spur track north of southward dwarf signal
MP 75.8	Magnolia Siding to Arsenal Industrial Trk.
MP 80.9	Trk A to Chase Public Delivery
Point-Bay	North Point Yard Trk
Charles	Mount Vernon Ind Trk

132-P2. PENN STATION LIGHT RAIL TRACK - FOULING

Employees must not foul the Penn Station Light Rail Track (MTA track located to the east of No. 1 Track, Baltimore Station) without contacting the CETC Section 2 Dispatcher, and receiving assurance that protection has been provided by the MTA. When flag protection must be provided on the Penn Station Light Rail Track in accordance with Rules 132 or 136, the CETC Section 2 Dispatcher must be immediately notified. Flag protection must be maintained until it is determined that movements on the Penn Station Light Rail Track are no longer endangered, or until assured by the Dispatcher that other protection has been provided.

138-P1. PENN COACH YARD - ACCESS ROAD CROSSING

Trains operating in Penn Coach Yard must stop before passing over the access road crossing and sound engine bell (if equipped) until the crossing is occupied. If crew does not have a clear view of the access road in both directions, a member of the crew must provide on-ground protection.

241-P1. STOP SIGNALS

In the application of **Rule 241**, when **Stop Signal** is displayed on a signal at the following locations, the authority to pass it must be obtained through the Dispatcher listed below.

Location	Track	Governing Movements	Authority obtained from
CP Avenue	No. 2 & No. 3	Northward	CETC-1 TD

241-P2. DAVIS INTERLOCKING - STOP SIGNAL

Southbound trains that receive Rule 241 authority to pass Signal 10S at Davis must receive verbal permission from the Dispatcher before operating beyond the southern limits of Davis Interlocking on Track A, due to potential freight traffic on Track A between Davis and Iron. Signal 10S is the southbound interlocking signal on Track A located just north of Newark Station.

242-P1. PAUL: IMPERFECTLY DISPLAYED SIGNALS

The most restrictive indication that can be given by dwarf signal No. 5N is Restricting. No. 5N signal governs northward movements on No. 5 track, and is located 25 feet south of end of track.

277-P1. PERRY

The northward interlocking signal at Perry governing movement from No. 4 track to No. 4 track is located to the left of No. 4 track.

277-P2. CHARLES AND PAUL

Trains approaching Charles or Paul on a signal indication less favorable than Clear must not exceed 15 MPH within Charles or Paul interlocking until it is determined that their route permits a greater speed.

551-P1. TESTING SECTIONS

In addition to those at terminals, located:

Phila. 30th St. Station (Lower Level) Nos. 7 and 8 tracks, departure test for northward movement only.

Reybold Branch (NS)-On Reybold Branch from fixed signal 5430 feet south of Davis to a point 1320 feet south thereof.

Bay-On the Lawn Track (NS)

Baltimore-Nos. 1, 3, 4, 6, 7 and F for northward and southward movements. On-Board Tester can be used, provided the signals leaving those tracks are not displayed and a track shunt is applied ahead of the train.

Odenton-MW Base North end of yard tracks H and I.

Perryville-MW Base North end of yard tracks H and I.

580-P1. ACSES RULES IN EFFECT FOR ALL AMTRAK TRAINS

ACSES Rules 580 through 591 and all ACSES related Special Instructions are in effect on main tracks and controlled sidings between the south limits of Penn interlocking and CP Avenue for all Amtrak trains. Positive stop at Penn enforced northbound only, on Tracks 2 and 3. Positive stop is not in service northbound at CP Avenue or southbound at C Interlocking.

1. The controlling engine of all Amtrak trains operating in this territory must be equipped with on-board ACSES apparatus that is cut in and operative, except when failure occurs en route, or when hauled by an engine exempted in Special Instruction 580-S2.
2. Non-Amtrak Trains: Trains operated by railroads other than Amtrak are not required to be equipped with ACSES apparatus while operating in this territory.

583-P1. ACSES POSITIVE STOP: RADIO RELEASE

ACSES Positive Train Stop (PTS) radio release is in service for all interlocking home signals located within or adjacent to ACSES equipped territory.

706-P1. RADIO CHANNELS: PENN

Yard crews shifting wholly within the limits of Penn Coach Yard may use either channel 054-054 or 023-023. However, yard crews working within interlocking limits must use only radio channel 054-054.

706-P2. PORTABLE RADIO TRANSMISSIONS WITHIN THE B&P AND UNION TUNNELS

“BAL TN RD” channel is in service for portable radios between Charles and Fulton for the B&P Tunnel, and between Paul and Biddle for the Union Tunnel. Lower powered portable radio transmissions made on “BAL TN RD” within these limits are picked up by a repeater and retransmitted on Road Channel 054 at high enough power to be received by portable and/or engine radios also located within the tunnels. While the “BAL TN RD” channel transmits on the repeater frequency, it receives on Road Channel 054.

Note:

No adjustment is necessary for engine radios to communicate with portable radios while within the tunnels.

The CETC Dispatcher receives all transmissions made within the B&P and Union Tunnels on Road Channel 054 or “BAL TN RD”.

900-P1. DISPATCHERS: ASSIGNED TERRITORIES

DISPATCHER	TERRITORY
CETC-6	Holmes, inclusive to Penn, exclusive.
CETC-5	Penn Interlocking.
CETC-4	Penn, exclusive to Ragan, exclusive. No. 4 and No. 5 tracks, Phil to Arsenal, exclusive.
CETC-3	Ragan, inclusive to Gunpow, exclusive.
CETC-2	Gunpow, inclusive to Fulton, exclusive.
CETC-1	Fulton, inclusive to CP Avenue.

940-P1. CONDUCTORS AND ASSISTANT CONDUCTORS: 30TH STREET STATION

Conductors of Amtrak trains that originate or with dwell time at 30th Street St. Station because of an engine or equipment change must contact a Station Service representative without delay when train is ready for boarding and departure, in person or via radio channel 036-036.

Note: If unable to contact Station Service representative, Conductor must contact CETC-5 Dispatcher.

952-P1. MARC INSPECTION REPORTS AND FORMS

Engineers operating MARC Commuter trains on the Northeast Corridor may accept the locomotive calendar day inspection, air brake test and cab signal test as noted on prescribed MARC forms. Amtrak's MAP 100 will continue to be used for noting any defects, as well as ensuring safety seals have been applied and numbers properly noted.

The Washington Terminal District consists of Washington Terminal (Union Station, Coach Yard and Ivy City Maintenance Facility).

WASHINGTON TERMINAL (WT)

STATIONS	MP	INT	PS	NOTES
CP AVENUE R-CETC 1 TD (ML-Philadelphia to Washington)	134.6	1
C INTERLOCKING R-K TOWER (Metropolitan Sub. CSX) (MARC Wedge Yd)	135.0	X	...	4, 5
K TOWER	135.7	X	...	2, 5
WASHINGTON	136.0	...	X	...
A INTERLOCKING R-K TOWER	136.0	X	...	5
CP VIRGINIA (RF&P Subdivision) R-CSX "BD" TD (BAL)	137.1	X	...	3
DIVISION POST (CSX Baltimore Division)				

The direction from CP Avenue to CP Virginia is south.

Note 1: Northward controlled signals.

Note 2: In service as an Interlocking Station with Road Radio Channel 054-054 and Yard channels 001 & 002.

Note 3: CSX radio channel 096-096 and Dispatcher tone 20-3 are in service for BD Dispatcher in Baltimore, MD.

Note 4: Movements into and out of MARC's Wedge Yard are under the authority of the Train Director at K Tower.

Note 5: Equipped with slip switches. See SI 80-S1.

240-W1. SIGNAL RULES and TRACK DESIGNATIONS

Tracks between the following locations are numbered from West to East:

BETWEEN CP AVENUE & K TOWER:

- ▶ At the North end, 40 & 42.
- ▶ At the South end 38 through 42.

STATION TRACKS AT WASHINGTON:

- ▶ 7 through 20, 22 through 30.

BETWEEN A INTERLOCKING AND CP VIRGINIA:

- ▶ Southward and Northward Main Tracks.

Interlocking Rules 600 through 616 are in effect as follows:

- ▶ West Yard Track 4
- ▶ Tracks 38 through 42 between CP Avenue & K Tower;
- ▶ Station Tracks 7 through 16 & 30, between northward starting signals (home signals for K Int) and connection with Tracks 38 through 42;
- ▶ Station Tracks 17 through 20, entire track;
- ▶ Tracks 22 through 29 between "H" Signal Bridge & First St. Tunnel;
- ▶ Northward & Southward Main Tracks between North Portal First St. Tunnel and CP Virginia (CSX).
- ▶ Cab Signal System Rules 550 to 561, inclusive are in effect for northward and southward movements on Track 40 and Track 42 between Signal Bridge "H" and Avenue and for movements over No. 460 Crossover. Except as provided for in SI 550-W1, trains not equipped with Cab Signal System apparatus are prohibited on these tracks.

37-W1. MAXIMUM SPEEDS - WASHINGTON TERMINAL

Location (Between)	Psgr	Frnt
Connection with CSX north of New York Avenue OH Bridge or connection with Amtrak PW Line at CP Avenue & Signal Bridge "J"		
Tracks 40 & 42	45	10
All Other Tracks	20	10
Wye Bridge Switching Center All Tracks	10	10
Except Operating Over No. 624-A Switch	5	5
Signal Bridge "J" & Signal Bridge "H"		
Northward	20	10
Southward	15	10
Signal Bridge "H" and North Portal First Street Tunnel	15	10
North Portal First Street Tunnel and CP Virginia	25	10
Location (Between)	Restricted Speed not exceeding	
All yard tracks	15	10
Except West Leg Wye	10	10
Except Track 52	5	5
Through Car Washer, Short Leg Wye:		
Northward when washing	2	2
Either direction when not washing	15	10
Through HST Trainwash, Track 52:		
When washing	4	4
Engine Servicing & Car Shop Repair		
Tracks specified in SI 16-W3	5	5
Except Within HST Building	3	3

C-W1. QUALIFICATION FOR YARD & WORK TRAIN SERVICE-CONDUCTORS & ASSISTANT CONDUCTORS

Conductors must be qualified on the required physical characteristics before accepting assignment as a yard or work train Conductor. Conductors and Assistant Conductors absent from yard service for 6 months or longer must contact a Terminal Trainmaster before starting a yard assignment at Washington or Philadelphia Terminal. Conductors and Assistant Conductors who have not worked a regular assigned work train position for 6 months or longer must contact a Trainmaster or Road Foreman before working a regular work train assignment.

C-W2. QUALIFICATION TO OPERATE MOTORIZED VEHICLES IN WASHINGTON TERMINAL AND YARDS

Amtrak employees/contractors operating motorized vehicles in Washington Terminal and Yards are prohibited from crossing tracks until they complete the "Crossing Live Tracks with Motorized Vehicles Course" and receive a signed qualification card from their supervisor. Upon successful completion of the course, employees/contractors are responsible for their own safety when working on or about the track outside a protected worksite and to keep a lookout and move to a safe place in sufficient time on the approach of a train or track vehicle.

F-W1. FIRST STREET TUNNEL

When approaching tunnel, Passenger Trainmen will see that end and vestibule doors are closed. Interior lights of occupied passenger cars are to be fully lighted prior to entering tunnel.

Conductors of southbound revenue passenger trains will ensure that blower fans are turned off and intakes closed on all passenger cars except Amfleet I when passing through tunnel.

When an emergency condition exists, which will require the evacuation of a passenger train in the First Street Tunnel, and requires passengers to pass through manholes between the Northward and Southward Main tracks, such evacuation will not commence until the Conductor has communicated with the Train Director, K Tower and has received positive assurance that there are no train movements on the adjacent track. The Train Director, K Tower will be responsible to ensure all movements are restricted until the evacuation has been completed.

Within the tunnel, K Tower may be contacted on radio channel 054-054, or Washington Terminal yard channels. Telephones, equipped with switches to select dial line or direct line to K Tower, are installed in every fifth manhole (500 foot intervals) throughout the tunnel. Fire alarm pull stations located adjacent to telephones are out of service.

All trains operating through the First Street Tunnel must use radio channel 054-054. Northbound trains must change to 054-054 prior to entering First Street Tunnel. Southbound trains must remain on radio channel 054-054 until clearing south of the tunnel limits.

I-W1. REPORTING FIRES

The Washington Terminal Control Center (Telephone 2333) must be notified promptly when any fire is observed on or near Company property or is likely to affect the property.

R-W1. MEDICAL SERVICES

When employees or passengers in or enroute to Washington Terminal require medical attention, the Washington Terminal Control Center (2333) should be promptly notified to arrange for appropriate medical services, or ambulance if necessary.

1-W1. WASHINGTON TERMINAL YARD BULLETIN (WTYB)

► WTYB Authority:

The WTYB contains temporary restrictions and other instructions applicable to Washington Terminal. The WTYB may be used to modify applicable portions of Mid-Atlantic Bulletin Order pertaining to Washington Terminal. Amtrak Zone 2 employees in Washington Terminal yard service, Zone 5 employees in VRE service and MW employees must obtain the current WTYB when reporting for duty and have it with them while on duty.

MW employees operating or working on tracks of Washington Terminal must have the current WTYB, except employees operating track cars into Washington Terminal from the PW Line who are in possession of the TSRB.

Any employees who are required to operate in the Coach Yard or Ivy City Maintenance Facility and are not in possession of the WTYB, must first contact the Train Director at K Tower and obtain the current WTYB.

► Effective Times:

The Washington Terminal Yard Bulletin (WTYB) will be effective at **3:00 AM Daily**.

► WTYB Usage and Delivery:

Form D Line 1 may also be used to inform crews of temporary restrictions when this method is more efficient. Employees whose duties are affected must obtain the WTYB when reporting for duty and must have it with them while on duty. The WTYB will be electronically transmitted to the following Washington Terminal and VRE Sign-up locations:

Crew Dispatcher's Office, Trk 7, Washington
Yardmaster's Office, Coach Yard Building, Washington
VRE Crew Room, Coach Yard Building, Washington

1-W1. (Cont'd)

VRE Crossroads Yard, Fredericksburg

VRE Broad Run Yard, Manassas

K Tower, Washington

Crews must examine the WTYB to ensure that it is current, complete and legible. If no WTYB's are available at sign-up locations, the crew must contact K Tower for instructions.

► **Crews Working at Effective Time:**

Conductors, Assistant Conductors and Engineers already working or enroute will be governed by the WTYB in their possession until they receive a copy of the current WTYB. If the Train Director instructs a crew to obtain the new WTYB, the crew must verify receipt with the Train Director.

► **Temporary Speed Restrictions and Pertinent Instructions:**

Temporary speed restrictions or pertinent instructions may be added or canceled on the WTYB. Additions or cancellations must **not** be copied by an employee operating the controls of a moving train or engine. When dictating or repeating changes to the WTYB, employees must pronounce numerals digit-by-digit. Only authorized abbreviations may be used on the WTYB.

When a restriction or instruction is to be added, the Train Director must dictate the restriction or instruction to the Conductor, Engineer or other qualified employee on the affected train or engine. The receiving employee must copy the additional restriction or instruction in the space provided on the WTYB. The additional information must be correctly repeated to the Train Director before the "Time Effective" is given. If communication fails before the "Time Effective" is received, the train or engine must not proceed until communication is reestablished.

► **Effective Period of Added Restrictions or Instructions:**

Speed restrictions or instructions added to the WTYB will remain in effect until Canceled.

► **Canceling Restrictions:**

When a restriction or instruction is to be canceled, the Train Director will advise the Conductor, Engineer or other qualified employee on the affected train which restriction or instruction and corresponding line number will be canceled. Restrictions or instructions to be canceled must be correctly repeated to the Train Director before a "Time Canceled" is given. The employee must then draw a line through the canceled restriction/instruction.

► **Retention of the WTYB:**

Upon completion of their tour of duty, employees may discard their WTYB unless information has been added or canceled, in which case it must be retained and held available for inspection for 7 days.

1-W2. TEMPORARY SPEED RESTRICTION BULLETIN (TSRB)

Amtrak Zone 5 crews and Train & Engine Service employees of foreign railroads not operating to or from the PW Line are not required to obtain the Temporary Speed Restriction Bulletin (TSRB).

16-W1. BLUE SIGNAL PROTECTION - UNION STATION

Fixed overhead flashing blue signal lights in service on north and south ends of Station Tracks 7 through 20 and 22 through 30.

Illuminated blue signals signify that workmen are on, under, or between rolling equipment, and the restrictions of section (a) of Rule 16, apply to the entire track. **No movements of any kind are permitted.**

When fixed overhead flashing blue signal lights can not be extinguished due to malfunction, Form D Line 13 will be issued to cancel this SI, and permit movements out of the affected track. Prior to issuing the Form D, the Train Director must contact the employee who was afforded blue signal protection to confirm that all employees are clear of the track and that permission is granted for the movement.

16-W2. BLUE SIGNAL PROTECTION - IVY CITY MAINTENANCE FACILITY

At Ivy City Maintenance Facility, fixed blue signal lights are in service adjacent to Main Shop Tracks 1, 2, 5 & 6, S&I Tracks 7 & 8, HST Building Tracks 9, 10, 11, & 12, and fumigation track. When lights are illuminated, the restrictions of section (a) of Rule 16 will apply to the track between fixed derails.

16-W3. BLUE SIGNAL DERAILS

The following locomotive servicing and car shop repair tracks are equipped with hand-operated blue signal derails:

Ivy City Maintenance Facility:

Nos. 1, 2, 3, 4, B, D, 5 and 6 Main Shop Tracks.

Nos. 7 and 8 Service and Inspection Building Tracks.

Nos. 9, 10, 11, "C" and 12 HST building tracks.

Nos. 13, 14, 15, 16, 17 and 18 Storage Tracks.

Loco Storage 1 and 2, and No. 23 Motor Pit Tracks.

Nos. 24, 25, 26 and 27 Annex Building Tracks.

Wye Bridge Switching Center:

Fumigation Track

Movements on all of the above tracks must not exceed 5 MPH.

19-W1. ENGINE WHISTLE OR HORN SIGNALS

Warning signal 19(c) must be sounded by northbound movements out of First Street Tunnel to warn persons at south end of Lower Level Tracks 22 to 29.

Whistle posts in service north and south of CSX Transportation overhead bridge at Wye Bridge Switching center. All trains operating on Fumigation Track and Tracks 24, 51 and 52 must sound engine whistle signal 19(b) approaching and passing under CSXT bridge and over road crossing south of the bridge.

The requirements of rule 19(b) do not apply when approaching or passing standing trains on station platform tracks at Washington.

20-W1. ENGINE BELL

The bell of equipped trains must be sounded when approaching and adjacent to a station platform. The bell must continue to be sounded until the train has stopped.

34-W1. MOVEMENT OF TRAINS

Trains must avoid stopping diesel locomotives underneath windows at K Tower on Station Tracks 15 and 16, account of diesel exhaust.

Northbound trains arriving Tracks 22, 27, 28 or 29 will stop with rear of train clear of south switch of those tracks.

Northbound trains, with 15 cars or less, arriving on Tracks 23, 24, 25 or 26 will stop with rear of train as near as possible to bottom of stairways. Conductors will arrange these stops by use of communicating signal or radio.

Passenger trains arriving on Station Track 7 must not stop with engine under H Street overhead bridge. Push-pull trains of 3 cars will stop with headend at "Train Stop 3 Cars" sign.

"Train Stop" sign in service adjacent to Station Track 18, 40 feet north of the end of track. Trains arriving on this track from the Amtrak Main Line or from CSX must stop with their head end adjacent to the sign to facilitate inspection of the engine or control car.

"Train Stop" signs in service at south end of low level tracks 23, 24, 25 and 26. Engineers of arriving southbound trains will stop with south end of engine adjacent to train stop sign in accordance with the following instructions:

Tracks 23 and 24—

"Train Stop A" sign located at stairway at south end of platform for through trains with 12 cars or less.

34-W1. (Cont'd)

“Train Stop B” sign located 120 feet south of stairway for trains terminating at Washington.

“Train Stop C” sign located at extreme south end of platform for all through trains with 13 or more cars.

Tracks 25 and 26—

“Train Stop A” sign located at stairway at south end of platform for through trains with 16 cars or less.

“Train Stop B” sign located 120 feet south of stairway for all trains terminating at Washington.

“Train Stop C” sign located at extreme south end of platform for through trains with 17 or more cars.

All northward movements on Tracks 39 or 40 must clear “J” Signal Bridge prior to reversing movement.

34-W2. VIRGINIA RAILWAY EXPRESS

Conductor of northbound VRE trains arriving at Washington will, after completion of station work, press train start button to notify the Train Director when train is ready to proceed to the coach yard.

The Train Director will arrange for the use of Coach Yard tracks by VRE crews with the Yardmaster. Signal indication will be authority for train to occupy Coach Yard track.

When ready to depart for the station, Conductors of southbound VRE trains will notify the Yardmaster on Yard Radio Channel 001 (084-012), who will advise the Train Director. At other times, crews of VRE trains will monitor Road Channel 054-054.

34-W3. UNION STATION - TRACK 16

All passenger trains arriving and departing Station Track 16 must use the east side platform (facing Track 17). Guests for departing trains will be directed to the east side platform for boarding.

36-W1. AMFLEET CARS

Personnel handling or working on moving Amfleet equipment, must not pass from car to car, except as is necessary in the performance of duty, and only then when on tangent track.

36-W2. ROAD ENGINE CREWS

Road Engine Crews, when receiving their engine at the Station, must not move without permission of the Train Director, regardless of whether their engine is coupled to a train. On station tracks, the interlocking signal displayed for engine to proceed out of the track may be accepted as permission to proceed at Restricted Speed to the signal.

Road Engine Crews of through trains arriving at Washington must contact Train Director for instructions before securing their engines, unless relieved by a station engineer.

36-W3. STARTING TRAINS

Train Conductors must report at the Crew Dispatchers Office for instructions before going to their trains.

Conductors on Amtrak passenger trains that are scheduled to board passengers must contact a Station Service representative when the train is (1) ready for boarding, and (2) ready for departure. Trains may depart at scheduled departure time after being informed by the Station Service representative that the gate is closed and the Conductor and crew have confirmed the platform is clear.

Conductors must report immediately to the Train Director K Tower and the Washington Control Center any occurrence that will delay the on-time departure of their train.

36-W3. (Cont'd)

VRE and MARC Commuter Trains

Commuter trains may leave at scheduled departure time on proper signal from the Conductor. Any occurrence that would prevent a commuter train from departing on time must be reported to the Train Director K Tower and the Commuter Control Center.

36-W4. INITIAL TERMINAL BRAKE TEST

When an Initial Terminal Brake Test is completed on a train prior to the crew's arrival, the employee conducting the test will place Air Brake Test Certificate, MAP 1173, on the locomotive brake stand.

Before departure of trains whose air brakes have been pretested, engineer must make an application and release of the automatic brake and member of the train crew must ensure that brakes have applied and released on the rear car.

36-W5. IVY CITY MAINTENANCE FACILITY

All movements must make a complete stop at doorway prior to entering Main Shop, Service and Inspection, Annex or High Speed Rail Buildings. Before proceeding, a visual check of the building door must be made to ensure it is in proper position. Engine Bell must be sounded when entering or moving within these buildings.

A crewmember must be positioned on the apron outside the Ivy City Maintenance Building prior to making movements out of the building on trks 5 and 6 shop, and 7 & 8 S&I. The crewmember shall ascertain there is no conflicting vehicular traffic on the apron before permitting the move to proceed.

36-W6. CAR WASHER—SHORT LEG OF WYE

Crews operating through the car washer on the short leg of the wye must exercise caution due to close clearance with the apparatus. When trains are to be washed, they must come to a complete stop and not proceed until apparatus has begun to operate. Trains being washed must move northward only and must not exceed 2 MPH. Southward moves must not be made when the washer is in operation.

36-W7. HST TRAINWASH FACILITY—TRACK 52

All equipment other than a High Speed Trainset (HST) is prohibited from passing over the Hegenscheidt automated wheel inspection apparatus at south end of Trainwash Facility, due to weight restriction. Except in an emergency, diesel engines are prohibited within the Trainwash Facility, and must never pass over Hegenscheidt apparatus.

HST's must only operate in a northward direction when passing through trainwash apparatus, to avoid damaging apparatus. However, if it should become necessary to make reverse movement due to wheel inspection fault, reverse movement must not commence until operator is present to place trainwash apparatus in manual mode and supervise movement. HST must continue moving northward at prescribed speed until entire trainset clears north end of trainwash, to avoid premature trainwash shutdown.

Manual use of HST Power Car sanders is prohibited while passing over the Hegenscheidt automatic wheel inspection apparatus.

36-W8. STATION TRACKS—WASHINGTON TERMINAL

When a movement handled by yard engine enters a station track, crew member in charge, if not instructed as to move desired, will contact Train Director promptly.

36-W9. TURNTABLES

Trains must not proceed onto or off of a turntable until turntable rails are properly lined and secured.

36-W10. SECURING EQUIPMENT

In the application of Operating Rules 108 and 109, and AMT-3 Rule 3.5 (Air Brake and Train Handling Rules and Instructions), the following will govern the securing of equipment against movement:

- ▶ **Lite Engines** – Unattended lite engines must have handbrake or parking brake applied (if so equipped), and wheels chocked or skated.
- ▶ **Catenary Power Outages** – When notified of a catenary power outage, the Train Director must promptly arrange to have all electric equipment on affected tracks secured with chocks or skates to prevent movement until power is restored.
- ▶ **Union Station:**
HST's – Except in catenary power outages, the use of chocks or skates to protect High Speed Trainsets against movement is prohibited on Station Tracks.
Equipment, Other Than HST's – On Station Tracks, chocks or skates and handbrakes are required on one or more cars left standing unattended. However, the use of chocks or skates to protect against movement is prohibited on any passenger train that has an engine attached on Station Tracks. After engine is attached to cars, the Mechanical department employee completing the coupling will remove the chock or skate from the rear of the train. Trains with engine attached must be secured with engine parking/handbrake applied, full service application, independent brake in full application, reverser removed or locked in place, and a minimum of two hand brakes applied on cars, as outlined in AMT-3, Rule 3.5.
- ▶ **Removing Chocks & Skates** - Wheel chocks and skates must be removed from railhead under equipment prior to moving cars or engines. Chocks or skates must not be removed until cars are coupled to an engine or power car, or equipment is secured against movement by other means, including sufficient handbrakes.
- ▶ **Ivy City Shop & Storage Tracks** – Equipment at the south end of tracks must have two (2) handbrakes applied.

40-W1. ENGINE AND EQUIPMENT RESTRICTIONS

The numbers shown in the columns to the right of each listed location specify the maximum height of the engines and equipment that may be operated. Engine and equipment dimension specifications are assigned in S.I. 37-S5 (page 289) for equipment authorized to operate on the NEC and in Washington Terminal.

Notes shown in parentheses in the location column are defined at the end of the table.

Location	Tracks
	Other
Avenue & K Tower: All tracks	5
Except 42 Trk north of K signal bridge	4
WUT Station: (a)	...
Track Nos. 7 to 11	5
Track Nos. 12 to 14	4
Track Nos. 15 to 16	5
Track Nos. 17 to 20	4
Track Nos. 22 to 30 (b)	5
First Street tunnels	5
High Speed Rail S&I Building, all tracks	1
Ivy City, Wye Bridge Switching Center, West Yard: All Tracks	5

- Notes:**
- a. Capitoliner Control Car 9637 is prohibited from operating in Washington Terminal.
 - b. Cars greater than equipment dimension code 1 (Clearance Code A for Private Cars) are not permitted to operate over the turnout on Track No. 27 south of southbound (16RC) signal. Exception: Restriction does not apply to VRE Cars.

41-W1. CWR EQUIPMENT

CWR (Continuous Welded Rail) Trains are permitted on Track 40 and 42 between “H” Signal Bridge and Avenue, and over No. 460 Crossover, C Interlocking. CWR Trains are restricted from operating all other tracks in the Washington Terminal.

41-W2. SUPERLINER AND HIGH LEVEL CARS

Superliner Cars 31000 through 38068 and High Level Cars 39940 through 39985 are equipped with high diaphragms. Transition Cars 39000 through 39046 and 39900 through 39939 are equipped with high diaphragms on only one end. The low diaphragms on the opposite end are compatible with conventional single level cars. Cars equipped with tubular type diaphragms may be coupled to the high ends of Superliners, high level and transition cars without restriction.

Prior to coupling, crews must observe the diaphragms on all equipment to ensure that they are compatible. Cars with diaphragms not compatible may be coupled and moved on straight track with permission of the Yardmaster, but must never be coupled or moved on curves or diverging movements through switches.

41-W3. MOVEMENT OF MARC & VRE CAB CARS

Kawasaki bi-level Cab Cars MARC 7845-7854, VRE V701-V704 and VRE Mafersa Cab Cars V901-V910 must not be moved in Washington Terminal without main reservoir air applied and inflated air bellows, due to insufficient clearance of pilot and cab signal pickup bar.

47-W1. ELECTRICAL OPERATION—FIRST ST. TUNNEL

Illuminated signs displaying letters ACMS vertically, located 470 feet south of north portal, to the right of Northward and Southward Main Tracks, indicate southward limits of catenary. Electric equipment must not pass these A.C. Motor Stop signs with the pantograph raised.

47-W2. IVY CITY MAINTENANCE FACILITY

1. Portions of the following tracks are in service for AC electrical operation, as specified below:

Tracks 9, 10, and 13–18: entire track

Track 11: Entire track, except from a point 115 feet south of building to a point (within building) 300 feet north thereof, as indicated by AC Motor Stop signs.

Trk 12: Entire track, except that portion from a point 115 feet south of High Speed Rail building to a point 185 feet north of the building as indicated by AC Motor Stop signs.

High Speed Rail Building: Movements within the HSR building with raised pantograph are governed by SI 47-A1 (page 364).

2. Service and Inspection Building:

Nos. 7 and 8 Tracks, S&I Building, are equipped with red and green lights at entrance doors to indicate status of the short section of catenary extending from 100 feet outside of building to a point 20 feet into the doorway. Within the S&I Building, indicator lights along east and west sides at both ends and center of building indicate status of the catenary section within the building on each track.

A red light indicates catenary section is energized. A green light indicates section is not energized and electric engines with pantograph raised must not pass onto that catenary section. If both indicator lights are dark, M of E foreman must be contacted to ascertain that catenary section is energized before attempting movement with pantograph raised.

3. Electric Locomotive Pit:

Red and green lights in service at north and south ends of Electric Locomotive Pit structure to indicate status of catenary section on No. 23 track extending from 125 feet south of pit to a point 75 feet north of pit. Employees will be governed by the same instructions as for Nos. 7 and 8 S&I Tracks.

4. Diesel Service Facility:

Catenary section on Track 26 from 175 feet south of Annex Building to a point 90 feet north of the building is normally de-energized. Electric engines with pantograph raised must not enter this section unless advised by diesel foreman that catenary has been energized.

47-W3. ELECTRICAL OPERATION: EMPLOYEES

Employees must not climb above floor level of locomotives or cars on any track equipped with catenary wires unless authorized by an Electric Traction Department Class A employee after catenary has been de-energized and properly grounded.

If necessary to climb on locomotives or cars on a track not equipped with catenary, employees must first note the position of any nearby overhead wires.

Employees must not approach within three feet of any overhead wire or other part of the catenary system. They must not touch dangling wires or foreign objects which may be in contact with overhead wires, but must report their location immediately to the Train Director, K Tower and warn other persons of their location.

Employees whose duties are in any way affected must comply with the Electrical Operating Instructions AMT-2. Employees who are qualified on AMT-2 must maintain and have with them while on duty a copy of the AMT-2 Electrical Operating Instructions.

47-W4. OPERATION OF ELECTRIC ENGINES

When moving lite electric engines with pantographs up between Ivy City and Washington Terminal the following will apply:

- a. A maximum of six electric engines will be allowed in a consist.
- b. The 27 point MU cable requirement listed in AMT-2, 3.110(A) is not required.

When handling more than three engines, operating speed must not exceed 15 MPH.

47-W5. RECONFIGURING PANTOGRAPHS IN HIGH SPEED RAIL FACILITY

Transportation employees are permitted to reconfigure pantographs within the High Speed Rail Facility (HSR), as long as no pantographs are raised in de-energized territory or between the AC Motor Stop Signs. In order to facilitate movement in the HSR, additional signs used in conjunction with the AC Motor Stop Signs have been placed in service, as illustrated to the right. These signs indicate the point at which it is permissible to raise pantographs. These additional signs are located on the west side of Track 12 at the High Speed S&I facility, and are erected 61 feet north of the AC Motor Stop Sign on the north end and 61 feet south of the AC Motor Stop Sign on the south end. These signs are placed at a height that can be seen clearly from the cab of a Power Car. Lowered pantographs are not to be raised until the cab side window on the appropriate end of a high speed trainset is adjacent to these signs.



70-W1. SHOP OR OUT-OF-SERVICE EQUIPMENT TAGS

Yard crews must be alert for and immediately advise the Yardmaster or Train Director when "Shop" or "Out-of-Service" tags are found on any equipment in train consists.

94-W1. PUSH-PULL TRAINS

Rule 94, part (b), does not apply in Washington Terminal.

98-W1. END OF TRACK INDICATORS

End of track indicators displaying two red lights are installed at the south end of Station Tracks 7 through 16 to assist crews of arriving trains in locating the ends of these tracks. Although these indicators display red as their aspect, they do not indicate Stop.

98-W2. WYE BRIDGE SWITCHING CENTER

Movements through Wye Bridge Switching Center are governed by the indications of fixed signals controlled by the Train Director, K Tower. Control of yard tracks and authority to occupy tracks in Ivy City Maintenance Facility or Coach Yard must be granted in accordance with SI 98-W3.

Wye Bridge Switching Center is not an Interlocking, however Interlocking Rules 600 through 616 govern operations at Wye Bridge Switching Center.

All southward movements on 51 Trk must clear southern limits of Wye Bridge Switching center (Sig No. 613) prior to reversing movements, unless otherwise instructed by the Train Director.

98-W3. CONTROL OF YARD TRACKS

1. Coach Yard - Tracks 50, 51 and 52

The Train Director, K Tower, is in charge of Coach Yard tracks 50, 51 and 52. Signal indication will be authority to occupy these tracks.

2. Ivy City - Car Shop and Locomotive Servicing Tracks

The following Ivy City Maintenance Facility tracks are designated Car Shop Repair and Locomotive Servicing Tracks.

Authority of the employee named must be obtained before any movement is made. Yardmaster may be contacted on channel 084-012 (WT-1). Mechanical personnel may be contacted on channel 069-016 (WT-002). High Speed Rail Foreman may be contacted on Yard Channel 001.

TRACKS	CONTROLLED BY
Trks 1 & 2, Main Shop, between derail on south end to fouling point of switch (No. 904) connecting with Trk 3 at north end	Engine House Foreman
Loco Storage 1 & 2, Track 23 between fouling point of switch (No. 988) connecting with Track 19 at south end and fouling point of switch (No. 940) connecting with Trk 9 at north end	Motor Pit Foreman
Trks 9, 10, 11 & 12, within High Speed Rail Building	High Speed Rail Foreman
Annex Building Trks 24, 25, 26 and Turntable Trk	Diesel Pit Foreman
Trk 35	Yardmaster
All other Ivy City Maintenance Facility trks, except trk 19 (Track 19 is not a shop track)	Employee who establishes blue signal protection; controlled by Yardmaster at other times

3. Yardmaster

The Yardmaster is in charge of movements on all other tracks in the Ivy City Maintenance Facility and Coach Yard. Crews who report for duty at Ivy City or Coach Yard or arrive at the Coach Yard from the Station, except Road VRE Crews, must contact the Yardmaster promptly for instructions. All Crews must contact the Yardmaster prior to occupying Short, East or West legs of Wye. **Authority to occupy any yard track does not insure that the track is clear of other movements or relieve employees from operating RESTRICTED SPEED.**

100-W1. COUPLING OUTBOUND ROAD LOCOMOTIVES TO EQUIPMENT

A Mechanical Department Car Inspector or Foreman must be present to observe, inspect and approve all couplings of outbound road locomotives to equipment when making up a train for departure. A coupling will not be considered complete until so inspected and approved.

100-W2. COUPLING TO AMTRAK INSPECTION CAR 10001

Equipment must not couple to or butt knuckles with Amtrak Inspection Car 10001 while in WT Station tracks without permission of the Train Director, K Tower.

104-W1. NORMAL POSITION OF HAND-OPERATED SWITCHES

The following switches must be returned to normal position after any reverse movement. East Leg Spur switch No. 810, West Wye Lead switch No. 824, and No. 968 switch leading from Ivy City Track 11 to Track C must be locked when not in use.

Location	Normal Position
COACH YARD	
East end of crossover from West Wye Lead to West Storage Lead (No. 824)	For West Storage Lead
Switch leading from East Leg to East Leg Spur track (No. 810)	For East Leg
IVY CITY	
Switch leading from Trk 11 to Trk C (No. 968)	For Trk 11
Switch leading from Trk 25 to Trk 27, South of Annex Building (No. 998)	For Trk 27
Switch leading from Trk 27 to Trk 26, South of Annex Building (No. 915)	For Trk 26

104-W2. POWER-ASSISTED MANUAL SWITCH

No. 826 turnout in West Storage Lead leading to Short Leg of Wye, No. 820 turnout in Short Leg of Wye leading to West Leg, and No. 812 turnout in Short Leg of Wye leading to East Leg, are “Hydra” power-assisted manual switches. Rule 104 applies to the use of this switch.

Switch must be manually lined for all trailing and facing movements. Facing point movements must come to a complete stop before switch is operated. Switch must not be operated while any movement is passing over the switch.

Switch is operated by pressing button in box adjacent to the switch for two seconds. If switch fails to complete movement for any cause, it will return to the original position. After operation, switch points must be examined to ensure points fit the rail properly.

116-W1. BACK-UP HOSE

A back-up hose must be used when backing or shoving cars in Washington Terminal. When an engine or control car is on the leading end of the backup movement, the Automatic Brake Valve or Emergency Brake Valve on that engine or control car may be used as a substitute for a back-up hose. Occupied passenger trains departing Washington may refer to SI 116-S2 when necessary to make a reverse move back into the terminal.

Exceptions:

1. Movement may be made without a back-up hose when conditions make it unsafe for the Conductor to ride on the leading car. In such a case, the Conductor must walk ahead of the train to direct movement.
2. Use of a back-up hose is not required when switching with 5 cars or less in Ivy City Maintenance Facility Shop tracks, or in the Coach Yard including Wye Bridge Switching Center.

116-W2. LOCATION OF ENGINEER: EXCEPTION TO SI 116-S1

Engineers may operate from other than the leading end of the movement when changing ends would occur between CP Avenue and CP Virginia, between Coach Yard and Ivy City Maintenance Facility, or at Wye Bridge Switching Center. Such movements must be made at Restricted Speed, not exceeding 15 MPH.

Note: This exception does not apply, and Engineers must operate from the leading end of:

1. High Speed Trainsets with a functional leading cab that are operating:
 - a. Southbound on station tracks 10 – 20,
 - b. In excess of 50 feet on Ivy City High Speed Maintenance Facility Tracks 9 – 12.
2. Single lite electric locomotives on which both operating compartments are functional. When necessary to change ends as outlined in items 1 & 2 above, AMT-3 instruction 2.5, “Locomotive Air Brake Test”, does not apply. However, all other AMT-3 train handling rules and instructions apply.

165-W1. FORM D ISSUANCE & DELIVERY PROCEDURES

Reporting for Duty Outside of the Northeast Corridor:

Conductors and Engineers of trains en route to the WT Line that report for duty at locations not on the Amtrak Northeast Corridor, or report at Washington for trains en route to outlying points, must check for Form D's issued for the Washington Terminal District and delivered by fax. Employees must examine Form D's for completeness and legibility, then communicate with K Tower to verify the number and date of each Form D received. Conductor and Engineer must both have a copy of each Form D. Failure to verify Form D's will result in delay to the train at Washington.

Form D's will be faxed to the following locations as required: Washington Transportation Building and Coach Yard VRE room, Crossroads, Broad Run, Richmond, Charlottesville, Newport News, Pittsburgh, CSX locations at Brunswick, Frederick, Jessup, Martinsburg and Riverside.

At locations where only one employee reports for duty, he must check and verify Form D as above, then deliver a copy of each Form D to the Conductor or Engineer with whom he will be working.

When a Conductor or Engineer is relieved after receiving Form D's, they must be delivered to the relieving Conductor or Engineer in accordance with Rule 173.

When crew members make multiple trips during a continuous tour of duty, Form D's received will remain in effect for all trips. Crewmember must notify K Tower that they will make multiple trips when verifying delivery of Form D.

Crew members given an interim period of release between trips must check and verify Form D's when reporting for duty after the period of release.

277-W1. NON-CONFORMING ASPECTS

The following signal aspects, not in conformity with the typical aspects illustrated in the NORAC Operating Rules, are in service in Washington Terminal: (Except on Northward Signals at CP Avenue)

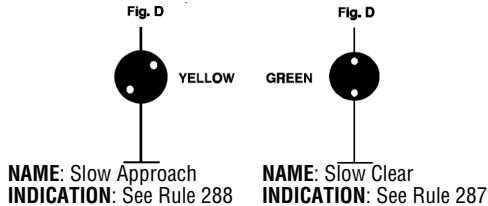

The following signal aspects illustrated in the NORAC Operating Rules will not apply in Washington Terminal, except on Northward Signals at CP Avenue: Rule 281, Fig. B (Clear) and Rule 285, Fig. B (Approach).

277-W2. NON-CONFORMING SIGNALS: FIRST STREET TUNNEL

The following signal aspect, not in conformity with the typical aspects illustrated in the NORAC Operating Rules is in service in the First Street Tunnel for southbound numbered signals 1367 at MP 136.7.

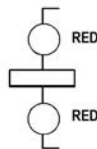

NAME: Restricting
INDICATION: See Rule 290

The signal aspects illustrated in the NORAC Operating Rules for Rule 291 will not apply to signals 1367.

550-W1. TRAIN NOT EQUIPPED WITH CAB SIGNALS

Trains without operative Cab Signals may operate on tracks where Cab Signal System rules are in effect. Such trains must operate at Restricted Speed and are governed by fixed signal indications. This exception does not apply to trains en route to the Main Line-Philadelphia to Washington.

613-W1. MOVEMENT OVER DERAILS

All split rail derails in Washington Terminal are self-restoring, with the exception of the split rail derail located on the south end of the Fumigation Track (Switch 620B).

Movements not governed by signal indication over derails located at the south ends of Station Tracks 22 through 29 must not be made without permission of the Train Director. This permission must include verification that derails are in proper position.

Before giving permission, the Train Director must confirm by model board indication that derails involved are in reverse (running) position and locked. When such situations are anticipated, the Train Director should throw and lock derails prior to initial movement over them. If position of derails cannot be confirmed, the Train Director must not give permission until train crew has verified that derails are in proper position for movement. After movements over derails are completed, the Train Director must return switch controls to the "NX" position to permit derails to restore.

701-W1. ENGINE RADIOS

Amtrak road engines must have radios tuned to channel 054-054. Yard engines must be tuned to Yard 001, channel 084-012. CSX freight and commuter trains will be tuned to the CSX road channel.

900-W1. DISPATCHER

Where the Operating Rules make reference to Dispatchers or Operators, such references will apply to the Train Director or Assistant Train Director K Tower.

900-W2. ASSIGNED TERRITORIES

Train Director K Tower: CP Avenue, exclusive to CP Virginia, exclusive.

902-W1. FORM D'S CP VIRGINIA

The CSX Dispatcher controlling CP Virginia will not be required to copy Form D Line 4 when the Line 4 limits extend to CP Virginia. Prior to issuing the Form D, the Train Director at K Tower must request blocking device protection from the CSX Dispatcher. The Train Director must record in his Form D book the name of the Dispatcher involved and the time the blocking devices are applied and removed.

952-W1. MARC INSPECTION REPORTS AND FORMS

Engineers operating MARC Commuter trains on the Northeast Corridor may accept the locomotive calendar day inspection, air brake test and cab signal test as noted on prescribed MARC forms. Amtrak's MAP 100 will continue to be used for noting any defects as well as ensuring safety seals have been applied and numbers properly noted.

MAIN LINE-PHILADELPHIA TO HARRISBURG (PH)

STATIONS	MP	INT	IS	PS	NOTES
ZOO (36th St Connection) (Main Line-SEPTA)	2.3	X	X	...	9, 15
STILES R-Zoo	3.5	X	1
VALLEY R-Overbrook (Ivy Ridge-SEPTA)	4.0	X	8
PAXON R-Zoo	4.1	X	7
WOODBINE R-Zoo	5.1	X	7
OVERBROOK	5.4	X	X	X	6
MERION	6.0	X	...
NARBERTH	6.8	X	...
WYNNEWOOD	7.5	X	...
ARDMORE	8.5	X	...
HAVERFORD	9.1	X	...
BRYN MAWR R-Paoli	10.1	X	...	X	13
ROSEMONT	10.9	X	...
VILLANOVA	12.0	X	...
RADNOR	13.0	X	...
ST. DAVIDS	13.8	X	...
WAYNE	14.5	X	...
STRAFFORD	15.4	X	...
DEVON	16.5	X	...
BERWYN	17.5	X	...
DAYLESFORD	18.6	X	...
PAOLI	19.9	X	X	X	6
MALVERN	21.6	X	...
FRAZER R-Thorn	23.9	X	12
GLEN R-Thorn (Dale Secondary Trk., NS)	25.3	X	1
EXTON	27.5	X	...
WHITFORD	28.3	X	...
DOWNNS R-Thorn	32.1	X
DOWNINGTOWN	32.4	X	...
THORN (No. 5 Running Trk)	35.0	X	X	...	3, 6
THORNDALE	35.3	X	...
CALN R-Thorn (No. 5 Running Trk)	36.6	X	2, 3
COATESVILLE	38.4	X	...
PARKESBURG	44.2	X	...
PARK R-See SI 900-G1	46.3	X	14
GAP	51.2
LEAMAN R-See SI 900-G1 (Strasburg R.R.)	57.0	X
HOLLAND R-See SI 900-G1 (New Holland Sec. Trk, NS)	66.1	X	11, 14
CONESTOGA R-See SI 900-G1	67.7	X	14
LANCASTER	68.0	X	...

MAIN LINE-PHILADELPHIA TO HARRISBURG (PH)

STATIONS	MP	INT	IS	PS	NOTES
CORK R-See SI 900-G1 (Columbia Sec. Trk., NS)	68.1	X	6, 14
LITITZ R-See SI 900-G1 (Lititz Sec. Trk, NS)	70.1	X	10, 14
MOUNT JOY	80.1	X	...
FLORIN	80.7
RHEEMS R-See SI 900-G1	83.4	X	14
ELIZABETHTOWN	86.8	X	...
ROY R-See SI 900-G1 (Royalton Branch, NS)	94.3	X	14
MIDDLETOWN	94.7	X	5
STATE	104.6	X	X	...	6, 15
HARRISBURG (Market St. Running Trk)	104.6	X	4
DIVISION POST (Pittsburgh Div. NS)	105.2

Mile Posts are numbered from Suburban Station (SEPTA).

The direction from Zoo to Division Post is Westward.

Note 1: Interlocking Rules apply on Nos. 2 & 4 tracks only.

Note 2: Interlocking Rules apply on Nos. 1 & 2 tracks only.

Note 3: No. 5 Running Track controlled by Thorn.

Note 4: Market St. Running Track between State & End of Track, controlled by State.

Note 5: Rule 121(c) applies on No. 2 track.

Note 6: Amtrak Road Radio Channel 035-035 in service.

Note 7: Interlocking Rules apply on No. 4 track only.

Note 8: Interlocking Rules apply on Nos. 1, 2, & 4 Valley Trks only.

Note 9: In service as an Int Station with Amtrak Road Radio Channels 035-035 & 054-054.

Note 10: Interlocking Rules apply on No. 2 & NS Lititz Secondary tracks only.

Note 11: Interlocking rules apply to No. 2 & New Holland Secondary tracks only.

Note 12: Equipped with Dual Control Switches.

Note 13: Equipped with Dual Control Switches, except No. 23 & No. 32 switches.

Note 14: Equipped with movable point frogs. See SI 80-S1.

Note 15: Equipped with slip switches. See SI 80-S1.

240-G1. SIGNAL RULES and CURRENT OF TRAFFIC

251: On tracks where Rule 251 is in effect, the letter in parentheses () denotes the current of traffic: E=East, W=West, N=North, S=South. ABS Rules and CSS Rules 550 through 561 are in effect for movements with the current of traffic. Non-Signalled DCS Rules are in effect for movements against the current of traffic.

261: On trks where Rule 261 is in effect, ABS Rules & CSS Rules 550–561 are in effect for movements in both directions.

562: On tracks where Rule 562 is in effect, Rule 261, ABS Rules, and CSS Rules 550 through 563 (except Rules 554 and 556), are in effect for movements in both directions.

Int: Indicates interlocking rules are in effect.

Locations	Tracks from North to South				
	4	3	2	1	Notes
Eastern Limits Zoo & 44th St	1
Eastern Limits Zoo & 38th St	2
36th St. & 44th St	3
Connection with No. 3 trk NYP Line at Girard Int & Connection with No. 4 trk (Zoo Int) at 44 th St.	4
Zoo & Overbrook	261	5
Zoo (44th St) & Stiles	Int	...	3

240-G1. (Cont'd)

Locations	Tracks from North to South				
	4	3	2	1	Notes
Zoo (44th St) & Valley: No. 4 Valley					251(W)
Stiles & Overbrook	Int	...	261	...	8
Overbrook & Paoli	251(W)	261	251(E)	251(E)	...
Paoli & Glen	251(W)	251(E)	...
Glen & Downs	251(W)	...	261	251(E)	...
Downs & Thorn	251(W)	...	251(E)	251(E)	7
Thorn & Caln	261	261	7
Thorn & Park	251(W)
Park & Leaman	562
Caln & Park	251(E)	...
Park & Conestoga	562	...
Leaman & Holland	562
Holland & Lititz	Int	...	3
Conestoga & Cork	Int	9
Cork & Rheems	562	...
Lititz & Rheems	562
Rheems & State	562	562	6
<p>Note 1: CSS Rules in effect on No. 1 trk for eastward movements & on No. 4 trk for westward movements.</p> <p>Note 2: CSS Rules in effect on No. 4 trk for eastward movements.</p> <p>Note 3: CSS Rules in effect on No. 2 trk for movements in both directions.</p> <p>Note 4: Int & CSS Rules in effect on New York & Pittsburgh Subway trk for movements in both directions, Girard Int to Zoo Int. Controlled by Zoo.</p> <p>Note 5: CSS Rules in effect on No. 1 trk for eastward movements only.</p> <p>Note 6: CSS Rules in effect on No. 2 trk for westward movements, between east limits State & Int Signal located 1000 feet west of MP 104. CSS Rules in effect on No. 1 trk for eastward movements, between Int Signal located 1450 west of MP 104 & east limits State.</p> <p>Note 7: Within Thorn Int trks are designated Nos. 4, 3, 6, 5, 2 & 1.</p> <p>Note 8: CSS Rules in effect on No. 4 trk for movements in both directions.</p> <p>Note 9: CSS Rules in effect on No. 1 trk for movements in both directions.</p>					

37-G1. PASSENGER TRAINS and FREIGHT TRAINS MAXIMUM SPEEDS and SPEED RESTRICTIONS, UNLESS OTHERWISE RESTRICTED

Locations and speeds shown in normal type are maximum authorized speeds. Locations and speeds shown in **bold type** are speed restrictions. *Maximum equipment speeds listed in SI 37-S5 (pgs 289-304) must not be exceeded.*

Where speeds change at an interlocking and the specific point where the speed change occurs is not specified, the lower speed will apply through the entire interlocking.

PASSENGER TRAIN TYPE "A" & "B" SPEEDS

Train Type A refers to High Speed Trainsets (HST) with tilt system **active**.

Train Type B refers to (1) HST's with tilt system **disabled**; and (2) trains consisting **exclusively** of HHP-8, AEM-7, ACS-64, P40BH, P42BH, P32AC-DM, or P32-BWH engines, and Amfleet, Horizon, Capitoliner Control Cars, LDSL Baggage Cars 61000-61084, MARC III control/coach cars, or US DOT test car DOTX 216.

Between/At	Train Type "A"				Train Type "B"			
	Track Nos.				Track Nos.			
	4	3	2	1	4	3	2	1
Eastern Limits Zoo & MP 3	50	...	30	50	50	...	30	50
Zoo: New York - Pitts Subway	15 MPH							
MP 3 & Western Limits Zoo	30	...	30	30	30	...	30	30
West Limits Zoo & West Limits Valley	60	60	60	60
No. 4 Valley Track	15 MPH							
West Limits Valley & East Limits Overbrook	60	65	60	65
Stiles & East Limits Overbrook	60	60
Within Overbrook Int.	70	30	50	65	70	30	50	65
West Limits Overbrook & East Limits Paoli Int.	70	80	80	70	70	80	80	70
Cv Between Merion & Narberth	60	75	75	60	60	75	75	60
Cv East of St. Davids (MP13.45 - 13.65)	60	60	60	60	60	60	60	60
Cv West of Devon	65	70	70	65	65	70	70	65
Cv East of Berwyn	50	50	50	50	50	50	50	50
Within Paoli Int.	65	30	30	60	65	30	30	60
West Limits Paoli & Glen	90	90	90	90
First 3 Cvs West of MP 21	75	75	75	75
Glen and Downs	90	...	30	90	90	...	30	90
First and Second Cvs West of Signal 295	60	60	60	60
Downs & West Limits Thorn	90	...	30	90	90	...	30	90
Within Thorn Int.	...	10	15	10	15	...
No. 5 Track	10 MPH							
West Limits Thorn & West Limits Caln	90	...	30	90	90	...	30	90
West Limits Caln & Signal 444	90	90	90	90
Signal 444 & MP 50	110	110	110	110
Cv West of MP 47	80	80	80	80
MP 50 & MP 54	90	90	90	90
Cv East of Gap	80	80	80	80

37-G1. (Cont'd)

PASSENGER TRAIN TYPE "A" & "B" SPEEDS

Train Type A refers to High Speed Trainsets (HST) with tilt system *active*.

Train Type B refers to (1) HST's with tilt system *disabled*; and (2) trains consisting *exclusively* of HHP-8, AEM-7, ACS-64, P40BH, P42BH, P32AC-DM, or P32-BWH engines, and Amfleet, Horizon, Capitoliner Control Cars, LDSL Baggage Cars 61000-61084, MARC III control/coach cars, or US DOT test car DOTX 216.

Between/At	Train Type "A"				Train Type "B"			
	Track Nos.				Track Nos.			
	4	3	2	1	4	3	2	1
Cv at Gap	55	55	55	55
Cv West of Gap	55	55	55	55
Cv at MP 53	80	80	80	80
MP 54 & MP 63	110	110	110	110
Cv at MP 56	105	105
Cv East of MP 59	100	100	100	100
Cv MP 59.6 & MP 59.7	105	105	105	105
Cv West of MP 60	85	85	85	85
Cv West of MP 61	85	85	85	85
MP 63 & E. Limits Holland Int.	110	110
MP 63 & MP 66	110	110
Cv MP 63.6 & MP 63.8	105	105
East Limits Holland Int. & West Limits Lititz Int.	60	60	...
MP 66 & MP 70	60	60
Conestoga and Cork: No. 7 Track								30 MPH
Eastward Tail Track								10 MPH
West Limits Lititz & MP 78	105	105	...
MP 70 & MP 78	105	105
Cv MP 77.1 & MP 77.3	100	100
Cv MP 77.6 & MP 77.8	100	100	100	100
MP 78 & MP 84	110	110	110	110
Cv MP 81.5 & MP 82.1	100	100	100	100
MP 84 & Roy Int.	100	100	100	100
Cv MP 84.7 & MP 85.4	85	85	85	85
Cv MP 85.9 & MP 86.2	85	85	85	85
Cv MP 92.9 & MP 93.5	85	85	85	85
Cv MP 93.5 & MP 94.0	95	95	95	95
Roy & E. Limits State Int.	110	110	110	110
Cv West of Middletown	80	80	80	80
Cv MP 97	105	105
Cv West of MP 102	105	105
MP 103.3 & E. Limits State Int	70	70	70	70
E. Limits State Int. & Int. Signal 1000' West of MP 104	50	50	50	50
Int. Signal 1000' West of MP 104 & Div Post	15	15	15	15

37-G1. (Cont'd)

PASSENGER TRAIN TYPE "C" & "D" SPEEDS

Train Type C refers to passenger trains that do not meet the criteria for train types A, B, or D.

Train Type D refers to passenger trains with mail, baggage or express cars in consist, that meet the Train Type D criteria defined in SI 37-S8.

NOTE: Train Type "D" trains must not exceed 60 MPH when operating with inoperative cab signals.

Between/At	Train Type "C"				Train Type "D"			
	Track Nos.				Track Nos.			
	4	3	2	1	4	3	2	1
Eastern Limits Zoo & MP 3	50	...	30	50	50	...	30	50
Zoo New York - Pitts Subway	15 MPH							
MP 3 & Western Limits Zoo	30	...	30	30	30	...	30	30
West Limits Zoo & West Limits Valley	60	60	60	60
No 4 Valley Track	15 MPH							
West Limits Valley & East Limits Overbrook	60	65	60	65
Stiles & East Limits Overbrook	60	60
Within Overbrook Int.	70	30	50	65	70	30	50	65
West Limits Overbrook & East Limits Paoli	70	80	80	70	70	80	80	70
Cv Between Merion & Narberth	60	65	65	60	60	65	65	60
Cv East of Rosemont	...	75	75	75	75	...
Cv West of Rosemont	...	75	75	75	75	...
Cv at Radnor	...	75	75	75	75	...
Cv East of St. Davids (MP13.45 - 13.65)	60	60	60	60	60	60	60	60
Cv West of Devon	65	70	70	65	65	70	70	65
Cv East of Berwyn	50	50	50	50	50	50	50	50
Within Paoli Int.	65	30	30	60	65	30	30	60
West Limits Paoli & Glen	90	90	90	90
First 3 Cvs West of MP 21	75	75	75	75
Glen and Downs	90	...	30	90	90	...	30	90
First and Second Cvs West of Signal 295	60	60	60	60
Downs and West Limits Thorn	90	...	30	90	90	...	30	90
Within Thorn Int.	...	10	15	10	15	...
No. 5 Track	10 MPH							
West Limits Thorn & West Limits Caln	90	...	30	90	90	...	30	90
West Limits Caln & Signal 444	90	90	90	90
Signal 444 & MP 50	110	110	90	90
Cv West of MP 47	80	80	80	80
Cvs between MP 48 & MP 50	100	100
MP 50 & MP 54	90	90	90	90
Cv East of Gap	80	80	80	80
Cv at Gap	55	55	55	55

37-G1. (Cont'd)

PASSENGER TRAIN TYPE "C" & "D" SPEEDS

Train Type C refers to passenger trains that do not meet the criteria for train types A, B, or D.

Train Type D refers to passenger trains with mail, baggage or express cars in consist, that meet the Train Type D criteria defined in SI 37-S8.

NOTE: Train Type "D" trains must not exceed 60 MPH when operating with inoperative cab signals.

Between/At	Train Type "C"				Train Type "D"			
	Track Nos.				Track Nos.			
	4	3	2	1	4	3	2	1
Cv West of Gap	55	55	55	55
Cv at MP 53	80	80	80	80
MP 54 & MP 63	105	105	90	90
Cv at MP 56	95
Cv MP 57.4 & MP 57.6
Cv East of MP 59	95	95
Cv MP 59.6 & MP 59.7	100
Cv West of MP 60	80	80	80	80
Cv West of MP 61	80	80	80	80
MP 63 & E. Limits Holland Int.	110	90
MP 63 & MP 66	110	90
Cv MP 63.6 & MP 63.8	95
East Limits Holland Int. & West Limits Lititz Int.	60	60	...
MP 66 & MP 70	60	60
Conestoga and Cork: No. 7 Track								30 MPH
Eastward Tail Track								10 MPH
West Limits Lititz & MP 78	95	90	...
MP 70 & MP 78	90	90
MP 78 & MP 84	110	110	90	90
Cv MP 81.5 & MP 82.1	100	100
Cv MP 83.6 & MP 84.3	100	100
MP 84 & Roy Int.	100	100	90	90
Cv MP 84.7 & MP 85.4	80	80	80	80
Cv MP 85.9 & MP 86.2	80	80	80	70
Cv MP 90.8 & MP 91.2	95
Cv MP 92.9 & MP 93.5	80	80	80	80
Cv MP 93.5 & MP 94.0	90	90
Roy & E. Limits State Int.	110	110	90	90
Cv West of Middletown	80	80	80	80
Cv East of MP 96	105
Cv MP 97	100
Cv West of MP 102	100
MP 103.3 & E. Limits State Int	70	70	70	70
E. Limits State Int. & Int. Signal 1000' West of MP 104	50	50	50	50
Int. Signal 1000' West of MP 104 & Div Post	15	15	15	15

37-G1. (Cont'd)				
FREIGHT TRAIN SPEEDS				
Between/At	Tracks			
	No. 4	No. 3	No. 2	No. 1
Eastern Limits Zoo & MP 3	20	...	20	20
Zoo: New York-Pitts. Subway	10 MPH			
MP 3 & West Limits Zoo	20	...	20	20
West Limits Zoo & East Limits Overbrook	20	...	30	20
No. 4 Valley	10 MPH			
Within Overbrook Int.	20	20	20	20
West Limits Overbrook & MP 7	35	25	25	25
MP 7 & MP 12	35	30	30	30
MP 12 & Devon	40	35	35	35
Devon & East Limits Paoli Int.	40	40	40	40
Within Paoli Int.	20	20	20	20
West Limits Paoli & Glen	40	50
Glen & Downs	50	...	25	50
First & Second Cvs west of Signal 295	40	40
Downs & West Limits Thorn	50	...	25	50
Within Thorn Int.	...	10	10	...
No. 5 Track	10 MPH			
West Limits Thorn & Caln	50	...	10	40
Caln & MP 63	50	50
Cv at Gap	40	40
Cv west of Gap	40	40
MP 63 & MP 66	40	50
MP 66 & East Limits Conestoga	40	30
East Limits Conestoga & West Limits of Cork	20	20
Conestoga & Cork				
No. 7 Track	30 MPH			
Eastward Tail Track	10 MPH			
West Limits Cork & Roy	40	40
Roy & State	40	45
East Limits State Int & Division Post	All tracks 10 MPH			

37-G2. SPEEDOMETER CHECKING-MEASURED MILES

The distance between the sets of Mile Posts listed below is a measured mile. White marker posts are installed on both sides of the track at these locations.

MP 9 - MP 10 MP 14 - MP 15	MP 24 - MP 25 MP 41 - MP 42	MP 88 - MP 89 MP 100 - MP 101
-------------------------------	--------------------------------	----------------------------------

37-G3. MAXIMUM SPEEDS-RUNNING TRACKS

Track	Between	And	Restricted Speed not exceeding
No. 5	Caln	Thorn	10 MPH

37-G4. MAXIMUM SPEEDS, OTHER TRACKS

Location	Track(s)	Restricted Speed not exceeding
State	East Leg of Wye	5 MPH
State	All trks within Dock St Yard	5 MPH
All Yard Tracks, Industrial Tracks and Public Delivery Tracks connected with Amtrak Main or Running Tracks		10 MPH

37-G5. WRECK and WIRE TRAINS

Between:	Wire Train	Boom Trailing	Boom Forward
		Miles Per Hour	
		Wreck	Wreck
Zoo & Paoli	50	40	30
Paoli & MP 44	40	40	40
MP 44 & Division Post MP 105.2	50	40	30

Note: Where speed of freight trains is slower than the speeds shown in this instruction, the freight train speed must not be exceeded.

37-G6. PASSENGER TRAINS WITH NON-PASSENGER CARRYING CARS IN CONSIST

A. Mixed Consist Trains of 14 cars or Less: Mixed consist trains of 14 cars or less may operate at passenger train speeds when they have at least one passenger carrying car for each non-passenger carrying car in consist. Mixed consist trains of 14 cars or less that do NOT have at least one passenger carrying car for each non-passenger carrying car, may operate at passenger train speeds, not exceeding the additional speed restrictions shown in item (D) below.

B. Mixed Consist Trains of 15 Cars or More: Mixed consist trains of 15 cars or more may operate at passenger train speeds, not exceeding the additional speed restrictions shown in item (D) below, when their consist includes:

1. At least 4 Amfleet, Horizon, Viewliner, or Heritage sleeper cars, **AND**
2. No more than 15 of the following cars in consist: 1500 series MHC cars, or 1000 or 1200 series baggage cars, **AND**
3. No more than a total of 30 cars.

Mixed consist trains that do not meet the above requirements must operate at freight train speeds.

C. Trains Consisting Exclusively of Non-Passenger Carrying Cars: Trains consisting exclusively of non-passenger carrying cars may operate at passenger train speeds, not exceeding the additional speed restrictions shown in item (D) below, when their consist includes:

1. No more than 10 of the following cars in consist: 1500 series MHC cars, or 1000 or 1200 series baggage cars, **AND**
2. No more than a total of 25 cars.

Trains consisting exclusively of non-passenger carrying cars that do not meet the above requirements must operate at freight train speeds.

– Continued on next page –

37-G6. (Cont'd)

D. Additional Speed Restrictions for Trains Referenced in Preceding Sections “A” thru “C”: The following additional speed restrictions apply to trains referenced in preceding sections “A” through “C”:

Between/At	Tracks	
	No. 4	No. 1
Eastern Limits Zoo & MP 3	40	...
West Limits Zoo & West Limits Valley	...	50
Stiles & East Limits Overbrook	50	...
Within Overbrook Int.	60	...
West Limits Paoli & Glen	70	85
Glen & Downs	85	...
West Limits Cork & MP 73	...	80
Roy & State	...	85

Note: The terms “mixed consist train”, “passenger carrying car”, and “non-passenger carrying car” are defined in Amtrak’s Air Brake and Train Handling Instructions (AMT-3).

40-G1. ENGINE AND EQUIPMENT RESTRICTIONS

The numbers shown in the columns to the right of each listed location specify the maximum height of the engines and equipment that may be operated. Engine and equipment dimension specifications are assigned in S.I. 37-S5 (page 289) for equipment authorized to operate on the NEC.

Notes shown in parentheses in the location column are defined at the end of the table.

Location	Tracks				
	4	3	2	1	Other
Zoo—Overbrook (a)	4	...	5	2	...
N.Y. & P. Subway-Zoo	4
Overbrook & Paoli (b)	4	5	5	4	...
Paoli & Glen	5	5	...
Glen & Downs	6	...	6	6	...
Downs & Thorn	6	...	6	6	...
Thorn & Park	6	...	6	6	...
Park & Cork	6	6	...
Cork & Roy	6	6	...
Roy & State	5	5	...
Roy & State, Via Royalton Br.	6
Harrisburg: Station Trks 5, 6, 7, 8	5	5	5	5	5

Note (a): Crews are limited to using **1** (one) locomotive when switching on the WBY Trk.

Note (b): SEPTA Engine 70 (2GS14B) is prohibited from operating on Track 4 past the high platform at Overbrook Station, but may operate all other locations as permitted by Equipment Dimension 3.

41-G1. NS TRACK GEOMETRY CARS

Norfolk Southern Track Geometry Cars Nos. 31, 33⁽¹⁾, 34 and 48 are cars that must be pulled by an engine. Their maximum speed is 50 MPH. Because of clearance concerns, movement must be made at Restricted Speed while passing high-level station platforms, and these cars may operate **only** on the following routes:

Location	Acceptable Routes
Cork-Thorn	Trks 1 & 4 (2 trk within Cork Int)
Thorn-Downs	Trks 2 & 4
Downs-Glen	Trks 2 & 4

Note 1: Car No. 33 is prohibited from passing high level platforms, except for the mini high platform on No. 4 track at Thorndale, and the mini high platforms at Exton.

41-G2. CARS EXCEEDING 263,000 POUNDS

NS Trains containing cars with gross weight not exceeding 286,000 pounds may operate over the following line segments:

- Cork to Roy - All tracks
- Frazer to MP 40 - All tracks

43-G1. CLOSE EQUIPMENT CLEARANCE: 42ND STREET OVERHEAD BRIDGE

Due to close overhead clearance, the Brown Hoist and Speno Ballast Cleaning Equipment and track sweepers must not be moved on No. 1 track under 42nd St. OH Br.

43-G2. CLOSE CLEARANCE: EMPLOYEES

1. **Bryn Mawr:** Caution must be exercised at the west end of No. 4 track due to close clearance with partial high level platform.
2. **Exton:** Caution must be exercised at the west end of No. 4 track and east end of No. 1 track due to close clearance with partial high level platforms.
3. **Harrisburg:**
 - Caution must be exercised when getting on and off engines at the west end of Nos. 6 and 7 tracks, due to close clearance with train shed roof.
 - Caution must be exercised due to close clearance with water stanchions placed between tracks. Except for No. 4 Track, employees must not ride on the side of equipment on any station track.
 - Employees using passageways under high platforms must exercise caution due to restricted vertical clearance, possible tripping hazards and moving equipment on adjacent tracks.
 - Close clearance exists between No. 1 Main Track and B-C Lead Track of Dock Street Yard, west of Route 83 OH Br, MP 103.4. Employees must not ride on side of equipment in this area.
4. **Overbrook:** Caution must be exercised on No. 1 and 4 tracks due to ADA ramps installed east and west of the station.

72-G1. TRAIN INSPECTION DETECTORS

Type of Detector	MP Location	Direction of Operation	Tracks(s)	Recorder Location	Notes
RA HB/DED	23.9	East & West	1 & 4	Frazer	1, 2
RA HB/DED	42.3	East & West	1 & 4	Pomeroy	1, 2
RA HB/DED	64.3	East & West	1 & 4	High Steel	1, 2
RA HB/DED	89.7	East & West	1 & 2	Conewago	1

Note 1: SI 72-S1 (page 313) applies.

Note 2: Detectors transmit on Road Radio channel 035-035.

72-G2. CARS WITH 6 AXLES

Private or Business cars which have six axles, must not exceed 100 MPH while passing over wayside hot box detectors.

In accordance with S.I. 34-S4 (page 279), Conductors in charge of trains with one or more of these cars in consist must notify their Engineer in writing of this restriction prior to leaving initial terminal (unless maximum speed for engine is 100 MPH or less).

104-G1. NORMAL POSITION OF SWITCHES AND CROSSOVERS AT SPECIFIED LOCATIONS:

Switch location	Connecting	With	Normal Position is for Movement	Note
Penn Coach Yard	Car Washing Trk	Run Down & No. 37 Trk	Through on Washing Trk	...

104-G2. SWITCHES EQUIPPED WITH ELECTRIC LOCKS

The following switches are equipped with an electric lock. Permission to remove the padlock from the keeper must be obtained from the Dispatcher unless otherwise noted.

Location	Track	Switch	Notes
Downingtown	4	Chester Valley Yard	1
MP 47.2	4	Keen & Son	...
MP 53.6	1	Kinzer Boat	...
MP 55.8	4	Stock Lumber East	...
MP 56.6	4	Stock Lumber West	...
MP 56.7	1	Eby Feed & Fertilizer	...
MP 57.9	4	Gordonville General Delivery	...
MP 64.8	1	High Steel	...
MP 66.8	1	Tail Track	2
Cork	All hand operated switches within Int		...
MP 74.13	1	Kellogg	...
MP 75.29	1	Snavely Lumber	...
MP 77.79	1	Esbenshade Feed	...
MP 77.99	2	Patricks	...
MP 78.48	2	Penfield Feed	...
MP 78.8	2	Mount Joy Wire	...
MP 81.01	2	Old Line	...
MP 81.08	1	Florin Feed	...
MP 81.54	2	Florin House	...
MP 83.9	1	Wenger Feed	...
MP 86.7	2	M&M Mars	...
MP 90.2	2	Conewago Ind. Trk.	...
MP 92.3	2	Metropolitan Edison	...
MP 95.2	2	M&H Railroad	...
MP 103.3	1	Dock St. Yard	...

Note 1: Permission must be obtained from the Train Director at Thorn.

Note 2: Electric lock switch on No. 1 trk must be reversed before operation of hand-operated derail on Tail Trk.

132-G1. TRACKS AND SWITCHES OUT OF SERVICE

The tracks and switches listed below are out of service for train movements, except when such movements are personally supervised by an MW Foreman or MW Supervisor, or when movement consists entirely of track cars.

If a remotely controlled switch provides access to an affected track, the Operator or Dispatcher must apply blocking device protection to prevent the accidental routing of trains to that track. If a hand operated switch provides access to an affected track, the last Engineering Department employee to use the switch must spike the switch to prevent its accidental use.

Location	Track/Switch
Penn Coach Yard	Rundown, Car Wash, & Wall tracks
Stiles-Girard	E. J. Track
Overbrook	Dump Siding Trk
Paoli	Fill out Trk
Downs & Barricade at MP 34	No. 2 Track
Cork Int	Plug Track

242-G1. PAXON: IMPERFECTLY DISPLAYED SIGNALS

The most restrictive indication that can be given by dwarf signal 55W is Restricting. Signal 55W governs westward movements on the SEPTA Maintenance Yard track, and is located 50 feet west of the crossover connecting No. 4 track to the SEPTA Maintenance Yard track.

242-G2. FRAZER: IMPERFECTLY DISPLAYED SIGNALS

The most restrictive indication that can be given by dwarf signals Nos. 55W and 66W is Restricting. Signal 55W governs westward movements on the Storage track, and is located 286 feet east of MP 24. Signal 66W governs westward movement on the East End Yard Lead, and is located 286 feet east of MP 24.

277-G1. ROY: SIGNAL ON LEFT

Home signal governing westward movement on No. 1 track located to the left of No. 1 track.

277-G2. RHEEMS: SIGNALS ON LEFT

Home signal governing eastward movement on No. 2 track located to the left of No. 2 track.

Home signal governing westward movement on No. 1 track located to the left of No. 1 track.

294-G1. SLIDE PROTECTION

Slide detector apparatus is in service between MP 90 and MP 90.2. The slide detector limits are marked by "SP" signs located at MP 89 and MP 91.

Trains operating between MP 89 and MP 91 that receive a cab signal aspect change to Restricting must operate through the slide detector limits prepared to stop short of an obstruction on the track.

Trains with inoperative cab signals and trains governed by DCS Rules (Rule 406 DCS substitution for ABS) must approach the slide detector prepared to stop short of an obstruction, and must not exceed Restricted Speed through the limits of the slide detector.

These restrictions apply to the head end only.

551-G1. TESTING SECTIONS

In addition to those at terminals, located:

Harrisburg-No. 6 tracks.

706-G1. RADIO FREQUENCIES

Radio channel 035-035 is in service between the western limits of Zoo Interlocking and Division Post MP 105.2. Westward trains entering Zoo Interlocking must use channel 054-054 when requesting a radio check from Zoo Interlocking Station (See S.I. 701-S1, page 349), but must change over to channel 035-035 upon departing Zoo Interlocking. A second radio check on channel 035-035 is not required. Eastward trains must change from channel 035-035 to channel 054-054 upon entering Zoo Interlocking, but do not need to make a radio check. (A radio test on one channel indicates that both channels are operative.)

900-G1. DISPATCHERS: ASSIGNED TERRITORIES

Monday through Friday 7:30 AM – 3:30 PM	
DISPATCHER	TERRITORY
Section B	Park (exclusive) to Division Post MP 105.2
Section C	Zoo to Park (inclusive)
All Other Times	
DISPATCHER	TERRITORY
Section C	Zoo to Division Post MP 105.2

940-G1. WESTBOUND HARRISBURG**950-G1. TRAINS**

Crews of westbound trains arriving at Harrisburg must contact the Train Director at State for instructions and must not leave train until released by the Train Director.

Note: This instruction does not apply to through trains at Harrisburg.

36TH STREET CONNECTION (36SC)

STATIONS	MP	INT	PS	NOTES
ZOO (ML-New York to Philadelphia) (ML-Philadelphia to Harrisburg) (ML-SEPTA)	0.0	X	...	1
PENN (ML-Philadelphia to Washington)	0.9	X	...	1

The direction from Zoo to Penn is eastward.

The 36th St. Connection extends from the connection with the PH Line at Zoo to the connection with the PW Line at Penn.

Note 1: Equipped with slip switches. See SI 80-S1.

240-C1. SIGNAL RULES and CURRENT OF TRAFFIC

Int. indicates interlocking rules in effect.

Location	Tracks from North to South		Notes
	No. 4	No. 1	
Zoo (Connection with PH Line) and Penn (Connection with PW Line)	Int	Int	1

Note 1: CSS Rules in effect for westward movements on No. 4 track, and for eastward movements on No. 1 track.

37-C1. PASSENGER TRAINS and FREIGHT TRAINS MAXIMUM SPEEDS and SPEED RESTRICTIONS, UNLESS OTHERWISE RESTRICTED

PASSENGER TRAIN SPEEDS			
Between/At	Tracks		
	No. 4	No. 1	
Zoo (Connection with PH Line) and Penn (Connection with PW Line)	30	30	

FREIGHT TRAIN SPEEDS			
Between/At	Tracks		
	No. 4	No. 1	
Zoo (Connection with PH Line) and Penn (Connection with PW Line)	10	10	

40-C1. ENGINE AND EQUIPMENT RESTRICTIONS

The numbers shown in the columns to the right of each listed location specify the maximum height of engines and equipment that may be operated. Engine and equipment dimension specifications are assigned in S.I. 37-S5 (page 289) for equipment authorized to operate on the NEC.

Notes shown in parentheses in the location column are defined at the end of the table.

Location	Tracks		
	1	4	Other
Zoo & Penn	5	5	5

43-C1. CLOSE CLEARANCE

Due to close clearance between tracks, crew members must request protection from the CETC 5 TD before riding the side of a material handling car to direct a shoving move southward from the 36th St. Connection to 30th St. Station. Crew members must notify the CETC 5 TD when the movement has been completed.

900-C1. DISPATCHERS: ASSIGNED TERRITORIES

DISPATCHER	TERRITORY
CETC-5	Penn
Section C	Zoo

LEHIGH LINE CONNECTION (LLC)

STATIONS	MP	INT	PS	NOTES
HUNTER R-Section B TD (ML-New York to Philadelphia)	0.0	X
HIGH R-Section B TD	0.3	X	...	1
DIVISION POST (CRC)	0.6	1, 2
NK (Lehigh Line - CRC)	11.4	X	...	3

The direction from Hunter to NK is westward.
Note 1: Mile Post distances are measured from Hunter.
Note 2: Division Post between Amtrak and CR located at eastward limit NK.
Note 3: Conrail MP designation.

240-L1. SIGNAL RULES and CURRENT OF TRAFFIC

Int. indicates interlocking rules in effect.

Location	Tracks from South to North		Notes
	No. 7	No. 6	
Hunter & High	Int	Int	1
High & NK	...	Int	2

Note 1: CSS Rules in effect for movements in both directions.
Note 2: CSS Rules in effect for westward movements only.

37-L1. PASSENGER TRAINS and FREIGHT TRAINS MAXIMUM SPEEDS and SPEED RESTRICTIONS, UNLESS OTHERWISE RESTRICTED

PASSENGER TRAIN SPEEDS		
Between/At	Tracks	
	No. 7	No. 6
Hunter & High	30	45
High & NK	...	45

FREIGHT TRAIN SPEEDS		
Between/At	Tracks	
	No. 7	No. 6
Hunter & High	10	10
High & NK	...	10

40-L1. ENGINE AND EQUIPMENT RESTRICTIONS

The numbers shown in the columns to the right of each listed location specify the maximum height of the engines and equipment that may be operated. Engine and equipment dimension specifications are assigned in S.I. 37-S5 (page 289) for equipment authorized to operate on the NEC.

Notes shown in parentheses in the location column are defined at the end of the table.

Location	Tracks		
	7	6	Other
Hunter & NK	5	5	...

900-L1. DISPATCHERS: ASSIGNED TERRITORIES

DISPATCHER	TERRITORY
Section B	Hunter (inclusive) to NK (exclusive)

SYSTEM SPECIAL INSTRUCTIONS

A-S1. COMMUTER TRAIN SCHEDULES

Trains of the following agencies will be governed by their public schedule while operating over Amtrak territory: CDOT, MARC, MBTA, NJT, SEPTA and VRE. Trains governed by the MARC Penn Line public schedule may depart Washington a minute later than the scheduled leaving time, if required by station work. Employees whose duties are affected by these trains must have a copy of the applicable public schedules in their possession while on duty.

A-S2. SAFETY INSTRUCTIONS

Train & Engine service employees, Mechanical Department employees, and Dispatchers & Operators are required to know the Safety Instruction of the day, including its meaning, intent and application. Conductors and Engineers will ensure that other members of their crew know and fully understand the instruction.

Train and Engine Service employees of other railroads will be governed by the home railroad Safety Rules.

A-S3. AIR BRAKE INSTRUCTIONS

Train and Engine Service employees of other Railroads will be governed by their home railroad air brake and train handling instructions, except as modified by AMTRAK Special Instruction.

A-S4. BOOKS IN EFFECT

The following books are in effect:

- ▶ NORAC Operating Rules, Tenth Edition, effective November 6, 2011. (Applies to all employees)
- ▶ Electrical Operating Instructions (AMT-2), revised and reissued November 15, 2005. (Applies to **all** employees who work in Amtrak electrified territory)
- ▶ Standards of Excellence (NRPC 2525), issued January 1, 1995. (Applies to all Amtrak employees.)
- ▶ Air Brake and Train Handling Instructions (AMT-3), revised & reissued March 2, 2015. (Applies to Amtrak Train & Engine Service and Mechanical Employees)
- ▶ Special Instructions Governing Operation of Signals and Interlockings (AMT-4), effective August 3, 1980, revised and reissued June 1, 2004. (Applies to Amtrak Dispatchers and Operators)
- ▶ NEC Train Dispatcher's Manual of Instructions, System, Boston, New York & Mid-Atlantic Office Sections reissued October 15, 2006. System section revised December 28, 2009; Boston Office section revised July 21, 2008; Mid-Atlantic Office section revised March 1, 2012. (Applies to Amtrak Dispatchers)
- ▶ Safety Instructions for Transportation Employees On Or About Locomotives, Cars or Equipment (AMT-5), issued January 5, 2009. (Applies to Amtrak Train & Engine Service employees, Dispatchers, Operators and Yardmasters)
- ▶ Safety Rules & Instructions for Amtrak Maintenance of Equipment Employees (NRPC-1905), effective January 1, 2009. (Applies to Amtrak Mechanical employees)
- ▶ Roadway Worker Protection Manual, revised Jan. 1, 2010. (Applies to Roadway Workers & Conductor Flagmen responsible for their protection)
- ▶ Service Standards for Train Service & On-Board Service Employees, Manual No. 9, revision 9.0, effective October 30, 2015. (Applies to Amtrak Train Service & OBS Employees)

A-S4. (Cont'd)

- ▶ Amtrak System General Road Foreman Notices, issued January 1, 2014. (Applies to Amtrak Engine Service Employees)
- ▶ Acela Quick Reference Handbook – Anomaly & Emergency Checklists, Version 1, issued January 16, 2012. (Applies to Amtrak Train and Engine service employees who operate HST equipment)
- ▶ United States Hazardous Materials Instructions for Rail, HM-1, effective January 4, 2011 (Applies to employees involved in movement of Hazardous Materials) (CR/NS HM-1, effective April 1, 2009 applies to Conrail and Norfolk Southern employees involved in movement of Hazardous Materials)
- ▶ Northeast Corridor Employee Timetable Appendix A, “Emergency Procedures for North River, East River and Empire Tunnels.” (Applies to all employees who operate through these tunnels)

B-S1. GOOD FAITH CHALLENGE

This instruction is intended to provide a mechanism for an employee to appeal, if the employee believes in good faith that a supervisor's instructions will cause the employee to violate one or more of the operating procedures governed by Federal Regulation 49CFR218 Subpart F, which pertains to shoving movements, leaving equipment in the foul of an adjacent track, and handling of hand-operated switches & fixed derails.

1. Right to Challenge

Federal Regulations have provisions that allow an employee the right to challenge a directive which, based upon the employee's good faith determination, would violate a railroad operating rule or special instruction relating to:

- Shoving movements,
- Leaving equipment in the foul of an adjacent track,

or

- Handling of hand-operated switches or fixed derails.

These Federal Regulations are not intended to abridge any rights or remedies available to the employee under collective bargaining agreements or Federal law.

2. Good Faith Challenge Procedure

a. An employee may inform a supervisor issuing a directive that a good faith determination has been made that the directive would violate a railroad operating rule or special instruction relating:

- Shoving movements,
- Leaving equipment in the foul of an adjacent track,

or

- Handling of hand-operated switches or fixed derails.

When informing the supervisor of their belief that the directive would result in a violation, the employee must clearly explain how the directive will cause a violation.

b. The supervisor will not require the employee to comply with the directive until the challenge is resolved. However, the supervisor may:

- Require the challenging employee to perform other tasks not related to the challenge until the challenge is resolved,

or

- Direct an employee, other than the challenging employee, to perform the challenged task before the challenge is resolved. Employee so directed will be informed of the challenge, and determine that the challenged task does not violate the rules.

B-S1. (Cont'd)

3. Resolving the Good Faith Challenge

- a. A challenge may be resolved by one of the following:
 - The supervisor's acceptance of the employee's request,
 - The employee's acceptance of the supervisor's directive,
 - The employee's agreement to a compromise solution acceptable to the person issuing the directive.
- b. If the challenge cannot be resolved because the supervisor issuing the directive has determined that the employee's challenge has not been made in good faith, or there is no alternative to the direct order, the railroad will:
 - Provide immediate review by at least one manager, which must not be conducted by the supervisor issuing the challenged directive or that supervisor's subordinate,
 - Resolve the challenge using the same options available for resolving the challenge as the initial supervisor.
- c. If the manager making the final decision concludes that the challenged directive would not cause the employee to violate any requirement of the involved rules, the reviewing manager's decision shall be final and not subject to further immediate review.
 - The manager will inform the employee that Federal law may protect the employee from retaliation, if the employee's refusal to do the work is a lawful, good faith act.
 - The employee making the challenge will be afforded an opportunity to document, in writing or electronically, any protest to the manager making the final decision before the employee's tour of duty is complete. The employee will be afforded the opportunity to retain a copy of the protest.

4. Request for Review and Verification of Decision

Upon written request, at the time of the challenge, the employee has the right for further review by the Senior Director - System Operating Practices. Within 30 days after the expiration of the month during which the challenge occurred, the Senior Director - System Operating Practices will verify the proper application of the rule in question. The verification decision shall be made in writing to the employee.

B-S2. CONFIDENTIAL CLOSE CALL REPORT SYSTEM (C³RS)

Amtrak has entered into a partnership with the Federal Railroad Administration (FRA), the Brotherhood of Locomotive Engineers and Trainmen (BLET) and the Sheet Metal, Air, Rail & Transportation Workers (SMART), the National Aeronautics and Space Administration (NASA), and the USDOT Volpe Center to implement a confidential close call reporting system as defined in the "Implementing Memorandum of Understanding" (C³RS/IMOU) finalized on May 11, 2010, and amended September 1, 2013.

A "close call" can be defined as a situation or incident that has the potential for more serious consequences. Personal injuries and/or train accidents of any kind do not fall into the category of a close call, and will continue to be reported and handled in accordance with the current or subsequent revisions to Amtrak rules and FRA regulations.

The confidential reporting system provides an environment in which railroad employees can voluntarily report close calls without fear of discipline or punishment.

A. Reporting a Close Call

NASA has developed a close call report form that requests information about the date, time, location, contributing factors, actions taken, and potential consequences of an event, along with any other information necessary to fully describe the event

B-S2. (Cont'd)

or perceived safety problem.

NASA C³RS forms are available at Amtrak sign-up locations, and a PDF version of the form can be downloaded from the C³RS website at <http://c3rs.arc.nasa.gov>, and then printed. The employee must complete the paper or printed PDF report form, and submit it in accordance with the instructions on the form. NASA will provide a receipt for the written close call report as proof of an accepted report. Additionally, employees will be able to use the Electronic Report Submission (ERS) function of the C³RS website to submit a close call report electronically.

The printed C³RS form should be mailed to NASA, or the Electronic Report Submission (ERS) function should be executed, within three calendar days from the date of the incident, not counting weekends and Federal Holidays.

After collecting information on a close call event, NASA removes all information that might lead to the identity of:

- The person who filed the report.
- Employees referred to in the report.
- Any information that would allow any employee to be identified.

B. Events Covered by Close Call Reporting

- Events that occur but have low consequences such as a run-through trailing point yard switch that does not result in a train accident, unsecured equipment, etc.
- Events involving damage or derailment **below** the FRA monetary reporting threshold* that do not involve an injury.
- Events that have the potential for high consequence such as speeding.

C. Events NOT Covered by Close Call Reporting

- Events wherein the employee's action or lack of action was intended to damage Amtrak or another entity's operations or equipment or to injure other individuals, or the employee's action or lack of action purposely places others in danger.
- Events wherein the employee's action or lack of action involved a criminal offense.
- Events wherein the employee's behavior involved substance abuse or inappropriate use of controlled substances.
- Events wherein the report is rejected because it is not safety related or it is incomplete.
- Events involving damage or derailment **above** the FRA monetary reporting threshold*.
- Events that caused or are alleged to have caused any injury, illness or medical treatment of any kind to any person involved in the event.
- Events that result in an identifiable release of a hazardous material.
- Events which were a real-time observations made by an FRA-certified inspector or railroad employee, and were reported to and verified by Amtrak management, except as provided for below:

Reporting a Close Call Involving Damage Below the FRA Monetary Reporting Threshold, or Witronics Alert

The following additional criteria are required for an event involving damage that is below the FRA monetary reporting threshold and/or on-board electronic train monitoring devices (Witronics) to be considered a close call:

1. The employee must provide notification of the event to an appropriate AMTRAK officer (e.g, a Yardmaster or Assistant Chief Train Dispatcher) prior to filing a C³RS report without undue delay;
2. The C³RS written report shall be completed and mailed to NASA within three

B-S2. (Cont'd)

calendar days from the date of the incident, not counting weekends and Federal Holidays.

3. The event must not result in damage or derailment that is above the FRA monetary reporting threshold*; and
4. The event must not cause, nor be alleged to have caused, an injury, illness, or medical treatment of any kind to any person.

NASA will provide a receipt for the written close call report as proof of an accepted report. The employee must allow AMTRAK to review the receipt, when requested.

D. Locations and Employees Covered by Close Call Reporting on the Amtrak System

The provisions of the C³RS/IMOU will apply to Amtrak T&E Employees working on the Amtrak System which consists of all trackage owned or controlled by Amtrak when covered by the BLET and SMART signatures of agreement on the C³RS/IMOU.

In addition, the provisions of the C3RS/IMOU will apply to all NJ Transit T&E employees working in Sunnyside Yard, Long Island City, NY.

* "Train Accident Reporting Threshold" as defined in 49 CFR Part 225

C-S1. NOTICE OF BLOCK TRAINING ATTENDANCE

Amtrak Transportation employees will be assigned to attend specific Block Training sessions for annual training. Names of employees selected for training will be published in Notices or General Notices in the month preceding their scheduled session. Attendance in the assigned class is mandatory. Selected employees must contact their supervisor to obtain travel and hotel accommodation information, when necessary. Authority to stay over at a hotel must be pre-approved through your supervisor. Train & Engine and On-Board Services employees will be automatically marked off by Crew Management to attend their Block Training session. All other employees should mark off through their normal processes. **Employees are required to mark up for duty upon return to their crew base immediately following the completion of their class.** Employees who have a conflict with their scheduled session date must contact their supervisor sufficiently in advance of the session for a change in assignment.

Employees are personally responsible for ensuring that they attend an annual Block Training session by the end of the calendar year.

C-S2. AMTRAK EMPLOYEES

In the application of NORAC Rule C, all Amtrak employees taking an Operating Rules examination must obtain a score of at least 88% to pass.

The 30-day grace period Specified in Rule C does not apply to Amtrak Train & Engine service employees, Train Dispatchers, and Block Operators. If an Amtrak employee in one of these crafts should fail to pass the annual NORAC Operating Rules examination on the first attempt, they must not perform service until they pass the examination.

Amtrak Train & Engine service employees must be prepared to take an annual signal examination covering any of the territory on which they are qualified. If an Amtrak T&E employee should fail to pass a signal examination with a score of 100%, they must not perform service until they pass the examination.

C-S3. OPERATING RULES QUALIFICATION

1. Employees in the following categories must be initially qualified on Operating Rules, and must be re-qualified annually:

- a. Train Dispatchers, Assistant Chief Dispatchers, and Block Operators
- b. Train & Engine Service employees, and Yardmasters
- c. Employees who move or assist in the movement of trains or engines

- f. C&S Maintainers
- g. Supervisors and Managers who directly supervise any of the above employees

2. For Engineering Department employees (“d”, “e” & “f” above), there are three NORAC Operating Rules qualification levels:

- a. **Class A Test** - Authorizes drivers to operate Specialized MW equipment (equipment that reliably shunts track circuits; see S.I. 803-S1, page 356) under the operating rules and physical characteristics qualifications that apply to freight trains, instead of the operating rules that apply to track cars.

- b. [Redacted]

- c. **Class C Test** - Authorizes employees to obtain foul time when properly qualified on physical characteristics.

3. Employees returning to duty after an absence from railroad service of 6 months or more must take the following actions before performing service that requires Operating Rules qualification:

After an Absence of:	Employee Must:
6 to 12 months	Attend and pass an annual Operating Rules re-qualification class.
Over 12 months	Attend and pass a special Operating Rules re-qualification class, as determined by Operating Practices Department.

C-S4. PHYSICAL CHARACTERISTICS QUALIFICATION — CONDUCTORS AND ENGINEERS

Conductors and Engineers must be qualified on the physical characteristics of the portion(s) of railroad over which they are to operate. Employees promoted to Engineer must qualify on the physical characteristics **specific to Engineers**, for the territory over which they will operate.

Remaining Qualified: To remain qualified while continuously employed in railroad service, an employee must have worked at least one trip in train or engine service during the previous 12 months, whether or not in the capacity of a Conductor or Engineer. Employees who are unable to work a trip in train or engine service may be authorized to make a special trip over portion(s) of the railroad to retain their qualifications. A Temporary Train Authorization Permit (form NRPC 2889) may be obtained from the General Manager or his designated representative.

The Temporary Train Authorization Permit (NRPC 2889) indicating the portion of the railroad over which the special trip was made, and validated by the Conductor or Engineer with whom the trip was made, must be presented to the designated officer, who will record the date in the employee's record of qualification file.

Employees who extend their qualification in this manner are prohibited from doing so two consecutive times. Engineers who extend their qualification in this manner must operate the train over the territory involved.

Any train or engine service employee who exceeds the time limits required to remain qualified as herein set forth must be re-examined by the proper officer before performing service as a Conductor or Engineer over the territory involved.

C-S4. (Cont'd)

Returning to Duty: Employees returning to duty after an absence from railroad service of 30 days or more must take the following actions before working as a Conductor or Engineer:

After an Absence of:	Employee Must:
30 days to 6 months	Contact the Operating Practices Department or a qualified Supervisor to determine what physical characteristics changes were made during the absence.
6 to 12 months	Same contact as above, plus make a head end ride over territory.
Over 12 months	Re-qualify on the territory.

Transferring From Another Railroad or Craft: Employees transferring to Amtrak Conductor or Engineer service from another railroad or craft who were previously qualified on the physical characteristics of Amtrak territory, must re-qualify on the physical characteristics of the territory over which they are to operate.

C-S5. QUALIFICATIONS FOR AMTRAK T&E EMPLOYEES TRANSFERRING TO DIFFERENT CREW BASE OR ROUTE

Amtrak Conductors, Engineers and Assistant Conductors transferring to a different crew base or route must not perform service without first having all Operating Rules and physical characteristics qualifications required for their territory and job assignment. Employees intending to transfer must contact the Operating Practices office to inquire about qualification requirements and the schedule of training classes.

To initially qualify on a new Operating Rule book, Assistant Conductors must attend training and pass an initial qualification examination. Promoted Conductors and Engineers not previously qualified to work as Conductor or Engineer under the Operating Rule book in effect on the new crew base or route must attend training and demonstrate their knowledge by passing an examination for Conductor or Engineer promotion, respectively. Employees will retain their original promotion date, as this examination is for qualification purposes, not promotion.

Operating Rules qualifications granted for operation in limited territory, such as a terminal, are not valid outside of the specified territory.

Only employees qualified on Operating Rules may qualify on physical characteristics.

C-S6. PHYSICAL CHARACTERISTICS QUALIFICATION FOR ENGINEERING DEPARTMENT EMPLOYEES

Note: Employees may re-qualify as early in the calendar year as they wish, and are encouraged to do so.

If your birthday occurs in:	You must re-qualify by:
January, February or March	March 31
April, May or June	June 30
July, August or September	September 30
October, November or December	December 31

Returning to Duty: Engineering Department employees returning to duty after an absence from railroad service of 30 days or more must take the following actions before working in a capacity that requires physical characteristics territory qualification:

C-S6. (Cont'd)

After an Absence of:	Employee Must:
30 days to 6 months	Contact the Operating Practices Department or a qualified Supervisor to determine what physical characteristics changes were made during their absence.
6 to 12 months	Same contact as above, plus make a head end ride over territory.
Over 12 months	Re-qualify on the territory.

C-S7. EMERGENCY PREPAREDNESS TRAINING

Amtrak Engineers, Conductors, Assistant Conductors and Train Dispatching personnel must complete Emergency Preparedness training during new hire training classes, and during the Block Training classes in which Emergency Preparedness refresher training is included every two years. This federally mandated training describes various emergency situations and the appropriate actions to be taken if an emergency occurs. Employees who do not complete the refresher class prior to the end of the two year period will not be permitted to perform service until they complete Emergency Preparedness training. Example: If an employee attended an Emergency Preparedness training class on July 8, 2011, they must attend a refresher class before December 31, 2013.

Employees needing Emergency Preparedness training must contact their supervisor in advance to allow sufficient time for class scheduling.

E-S1. POSSESSION OF FIREARMS

Employees are prohibited, unless authorized by Amtrak, from having firearms in their possession while on duty or on company property.

F-S1. PASSENGER TRAIN EMERGENCY SITUATIONS

The Dispatcher must be notified of any emergency related to the operation of passenger train service involving a significant threat to the safety or health of one or more persons requiring immediate action, including:

- ▶ A derailment
- ▶ A fatality at a grade crossing
- ▶ A passenger or employee fatality
- ▶ A serious illness or injury to one or more passengers or crew members requiring admission to a hospital
- ▶ An evacuation of a passenger train
- ▶ A security situation (e.g., a bomb threat)

A crew member shall quickly and accurately assess the situation and then notify the Dispatcher as soon as possible by the quickest available means. As appropriate, the crew member shall inform the passengers about the nature of the emergency and indicate what corrective countermeasures are in progress.

F-S2. CRITICAL INCIDENT STRESS PLAN

Amtrak's Critical Incident Stress Plan, developed in accordance with federal regulation 49 CFR Part 272, entitles certain employees who are directly involved in a critical incident to timely relief from their tour of duty after completing the actions necessary to ensure safety and the documentation of the incident. In addition to specifying which employees and events are covered, Amtrak's Critical Incident Stress Plan provides for covered employees to be transported to their home crew base as needed, makes counseling and other support services available upon request, and may provide covered employees with additional relief time if they remain in contact with an Employee Assistance Program counselor. A brochure containing additional information about Amtrak's Critical Incident Stress Plan is available in your local EAP office, and also on the Internet at <http://www.achievesolutions.net/AmtrakEAP> (go to "Amtrak Critical Incidents" in the "Quick Links" tab).

Employees are covered by the Critical Incident Stress Plan when they are:

1. Performing service covered under the federal Hours of Service law (49CFR228).
2. Railroad employees who inspect, install, repair, or maintain railroad right-of-way or structures.
3. Railroad employees who inspect, repair or maintain locomotives, passenger cars, or freight cars.

And they are directly involved in a critical incident because they:

4. Are closely connected to the critical incident, or
5. Witness the covered incident in person as it occurs, or
6. Witness in person the immediate effects of the covered incident, or
7. Are charged directly to intervene or respond to the covered incident (Exception: Amtrak Police Officers).

Critical incidents under this plan are:

- Accidents reportable to FRA (as per 49CFR225) because they result in fatality, loss of limb, or similarly serious bodily injury, or
- Catastrophic accidents reportable to FRA (as per 49CFR225) which could reasonably be expected to impair the ability of a directly involved employee to safely perform his or her job duties.

F-S3. HOST RAILROAD AND AMTRAK JOINT SECURITY PROCEDURES

Upon confirmation of a detonation of an explosive device on or at one of the following specified areas these procedures will be implemented:

- ▶ An Amtrak Train
- ▶ An Amtrak Station
- ▶ Any Railroad Infrastructures (Bridges, Tunnels) that passenger trains would operate over or through
- ▶ Any other U.S. rail operations (freight, commuter, subway)

These procedures can also be initiated if an imminent/confirmed threat has been determined based on credible information.

Notification

If an event, specific to an explosive device (i.e. detonation, discovery), occurs on-board an Amtrak train, the train crew will notify the dispatcher in the following manner:

“Emergency, Emergency, Emergency”, Train #____, (describe event).

Upon notification, the Train Dispatcher will repeat the emergency transmission to ensure all trains are notified and then attempt to obtain further information regarding the situation. The Train Dispatcher must then ensure the appropriate notifications are made to CNOC (800-424-0217) and the Amtrak National Communications Center (NCC) (800-331-0008).

Response

Unless otherwise directed by the Train Dispatcher, passenger trains hearing this emergency transmission must bring their train to a safe stop clear of passenger stations, tunnels, and bridges. Trains stopped at a passenger station, tunnel, or bridge at the time of the report must be dispatched clear of these structures as soon as possible.

Once a train is stopped clear of the above structures it must remain at that location until directed to proceed by the Train Dispatcher.

- ▶ When a train is stopped, crew members **will not** initiate an evacuation unless instructed by or coordinated with the Train Dispatcher, or the Conductor or any other crew member ascertains that a clear and present danger exists regarding an on-board threat or situation.
- ▶ If any evacuation of a passenger train occurs, the Train Dispatcher **must be notified immediately**.
- ▶ If directed to proceed by the train dispatcher, the En Route Train Inspection procedures will apply or if standing, the **Standing Train Inspection** procedures will apply.

En Route Train Inspection

Upon the implementation of the En Route Train Inspection procedures, the operating crews must take the following actions for all en route passenger trains including any special instructions from the Train Dispatcher:

1. Make the following announcement: *“On-Board Incidents with a Police Response Announcement”* from *“Service Standards for Train Service and On-Board Service Employees”* Chapter 10 - “On-Board Announcements & Signage” which reads: *“Ladies and gentlemen, we will be delayed [if not stopped, provide location where train will stop] due to police activity. At this time, we do not have an estimate for the length of this delay. We ask you to remain in your seats and please be prepared to identify your baggage and provide photo identification if requested. We apologize for any inconvenience and thank you for your patience.”*
2. The Conductor must make a public address announcement to **all** on-board employees that their **“immediate assistance”** is required at this time including the designated meeting location on the train.

F-S3. (Cont'd)

3. The Conductor will conduct a Job Briefing with all Train and On-Board Service employees to review the Host Railroad and Amtrak Joint Security Procedures and any instructions from the Train Dispatcher.
4. The Conductors will be in charge and have authority over all Train and On-Board Service employees. All employees (i.e. Chef, LSA's, SA's, TA's and AC's) must follow the Conductor's instructions; this is not discretionary.
5. The Conductor will assume the responsibility for simultaneously coordinating multiple inspections of equipment as follows:
 - ▶ The Train and On-Board Service employees will perform an interior inspection checking all restrooms, electrical lockers, overhead luggage racks and storage compartments for any unusual items. All findings must be reported to the Conductor.
 - ▶ Once the equipment has been inspected and cleared, Train and On-Board Service employees will go car-to-car matching luggage and personal belongings to the proper passenger while checking for proper photo identification. All findings must be reported to the Conductor.
 - ▶ In the event that crew members can not match carry-on items (unclaimed) or a suspicious package or device is found, all crew members and passengers will be required to move two (2) car lengths away from the package or suspected device and ensure that all bulkhead doors are closed and secured. No attempt should be made to touch the package or suspected device. As soon as all passengers and crew members are safely positioned away from the package or suspected device, the Conductor will immediately contact the Train Dispatcher with a description and location of the package or suspected device along with the car numbers of evacuated equipment.
 - ▶ In the event a passenger(s) cannot produce photo identification when requested, the crew should try to ascertain the name(s), date of birth and any other relevant information about the passenger(s). The information regarding passenger(s) without photo identification will be relayed to the Conductor who will inform the Amtrak National Communications Center (NCC) at 800-331-0008 of the situation and wait for further instructions.
 - ▶ The Train Crew should prepare for a possible evacuation of the entire train if instructed by the Train Dispatcher.

Standing Train Inspection

Upon the implementation of the Standing Train Inspection procedures, operating crews must take the following actions for all trains that are stopped, or will be stopping.

The Conductor will coordinate all instructions covered in the Inspection of En Route Trains section in addition to the following:

- ▶ The Locomotive Engineer will perform an interior and exterior inspection of the locomotive(s) looking for anything unusual. All findings must be reported to the Conductor. At the completion of the locomotive inspections, the Engineer should return and remain on the head-end of the locomotive.
- ▶ The Conductor will perform or designate a Train Service employee to perform an exterior inspection of the entire train looking for anything unusual or out-of-place. *(If a designated Train Service Employee is used, they will report the findings back to the Conductor.)*
- ▶ If an immediate emergency evacuation is needed, make the following announcement: *“Train Evacuation Where Baggage Must Be Left on Train Announcement”* from *“Service Standards for Train Service and On-Board Service Employees”* Chapter 10 - *“On-Board Announcements & Signage”* which reads:

F-S3. (Cont'd)

“Ladies and gentlemen thank you for your patience and cooperation. Due to the nature of the police activity, please leave your baggage on board the train and exit the train immediately as directed by a member of the crew.

Passengers on required medications are asked to retrieve them at this time and exit the train in an orderly fashion. We will provide you with more information as soon as possible. Thank you for your assistance.”

- ▶ If an evacuation is needed that is not an immediate emergency, make the following announcement: *“Train Evacuation Where Baggage May be Retained by Passengers Announcement”* from “Service Standards Manual” Chapter 10 - “On-Board Announcements & Signage” which reads: *“Ladies and gentlemen, due to the nature of the police activity, we ask that you gather all of your possessions and exit the train in an orderly fashion as directed by a member of the crew. We will provide you with more information as soon as possible. Thank you for your assistance.”*

G-S1. ALCOHOL AND DRUG TESTING

Any employee on duty, or reporting for duty, who is tested by breath or urine sample will be in violation of Rule G if:

- the initial breath test and confirmation breath test are positive: or,
- the urine screen test is positive and the confirmation test is positive for the presence of narcotics, sedatives, stimulants, hallucinogens, intoxicants or a derivative or combination of any of these, or any controlled substance or any mood altering substances.

Further, you may be required to provide a blood sample in the case of certain accidents and incidents subject to Federal post-accident testing requirements.

If you refuse to cooperate in providing a blood or urine sample following an accident (as specified in 49 CFR Part 219 Subpart C, you shall be removed from service, are subject to dismissal, and may not under any circumstances be employed in a position covered by the Hours of Service Act for a period of at least nine (9) months. A blood test that is positive for the presence of narcotics, sedatives, stimulants, hallucinogens, intoxicants or a derivative or combination of any of these, or any controlled substance or any mood altering substances will constitute a violation of Rule G.

G-S2. OPERATION REDBLOCK



OPERATION REDBLOCK is a labordeveloped, company-adopted drug and alcohol prevention and intervention program. The program emphasizes ***AWARENESS, PREVENTION AND EDUCATION.***

HISTORY:

Operation Redblock was started in 1983 on the Union Pacific Railroad by the United Transportation Union and the Brotherhood of Locomotive Engineers based on the idea that employees have the right to a drug and alcohol free work environment.

G-S2. (Cont'd)

GOALS:

TO PROMOTE a drug and alcohol free workplace;

TO PREVENT employees from reporting to work under the influence;

TO PREVENT substance abuse while on the job;

TO SAVE LIVES AND JOBS in the most humanistic way;

TO OUTREACH into the community.

PROCESS:

Union-led voluntary prevention committees form the basis of **OPERATION REDBLOCK**. Peer teams heighten co-workers' awareness of the dangers of drug and alcohol in the workplace through educational and promotional activities. Another main function of the peer teams is to perform confidential interventions of workplace abuse, and make referrals to **EMPLOYEE ASSISTANCE COUNSELORS** for professional assistance. Through the process, management and labor cooperate to support the peer teams' initiatives and Confidentiality.

BENEFITS:

- ◆ Reduced drug and alcohol use and abuse in the workplace.
- ◆ Changed worker attitudes toward drug and alcohol use in the workplace.
- ◆ Improved safety performance.
- ◆ Improved Labor and Management relations.
- ◆ Reduced discipline and cost of discipline.

SUMMARY:

OPERATION REDBLOCK is an innovative idea that combines traditional values of union fraternalism with progressive management to enable people to help people. Workers with substance abuse problems are confronted confidentially by co-workers and are **REHABILITATED—NOT PUNISHED, NOT FIRED, NOT FORGOTTEN**.

PROCEDURES FOR EMPLOYEES:

The following procedures are approved and supported by Amtrak:

1. If an employee is impaired because of the use of drugs or alcohol and cannot report for duty, he/she should call **1-800-44R-BLOC** and mark him/herself off as "**Operation Redblock**."
2. Once on the job, if an employee is observed as being unfit for duty, co-workers should tell the employee that he/she should not work and should mark-off as "**Operation Redblock**."
3. If the impaired worker places the call or requests a co-worker to mark him/her off, the reason should be given as an "**Operation Redblock**" procedure. No further action will be taken by Amtrak.
4. Should the impaired employee be uncooperative, the co-workers may use the Rule G Bypass Agreement and request help from the appropriate supervisor. The supervisor will then assist in removing the impaired employee and in getting him/her home. No Rule G charges will be made if the impaired co-worker contacts the Employee Assistance Program counselor within five days. Rule G Bypass is afforded to the employee only once.

These procedures were created for the common welfare of our employees, and to provide a safe workplace. Abuse of these procedures cannot be tolerated.

**FOR MARK-OFF ONLY, CALL
1-800-44R-BLOC.
FOR INFORMATION, CALL
(215) 349-2822, (ATS) 728-2822**

L-S1. AUTHORITY TO BOARD AND RIDE TRAINS

In the application of Rule L, authority to board and ride trains on the Northeast Corridor is granted as follows:

(1) Authorization

Only authorized persons are permitted to ride Amtrak locomotives and/or trains without transportation. Persons required to qualify on the physical characteristics or perform services and/or inspections must have in their possession at least one type of authorization as listed below. Each person authorized to board Amtrak locomotives and/or trains to qualify on the physical characteristics or perform services and/or inspections must identify themselves to the Engineer or Conductor and show proper credentials and authorization. Inspectors should also identify themselves to any official present. Whenever traveling for non-business purposes, inspectors must purchase proper transportation.

(2) Types of Authorization:

A. Amtrak Head End and Train Authorization Permit - Photo ID authorizes bearer to ride head end or body of train to learn physical characteristics or perform services and/or inspections.

B. Amtrak Train Inspection Permit - Photo ID authorizes bearer to ride body of train (*not head end*) to perform services and/or inspections.

C. Amtrak Temporary Train Authorization Permit (NRPC 2889 02/04) - Authorizes bearer to ride head end or body of train to learn physical characteristics, or perform services and/or inspections. Permit must indicate whether "Head End and Train" or "Train Only".

D. Amtrak Police Identification -

1. System Wide - With a photograph, authorizes Amtrak Police Officers to board and ride head end or body of all Amtrak trains.

2. Amtrak Property - With a photograph, authorizes Amtrak Police Officers to board and ride head end or body of all trains operating on Amtrak property (Northeast Corridor, Chicago Terminal, etc.).

E. Photo ID of Individual Working for a Municipal, State or Federal Regulatory Agency - Authorizes inspectors and employees of such agencies to ride head end or body of Amtrak trains to perform services and/or inspections.

F. Valid Head End Permit from Other Railroads/ Transportation Authority (On Amtrak property between Washington, DC and Boston, MA) - Authorizes bearer to ride head end to perform services and/or inspections on passenger trains other than those in Amtrak service. When doing so they must comply with all Amtrak rules, procedures and instructions.

G. Valid Head End Permit from Other Railroads/ Transportation Authority (On other than Amtrak property between Washington, DC and Boston, MA) - Authorizes bearer to ride head end to perform services and/or inspections.

(3) Head End Occupancy with Student Engineer Present

Only persons in the following categories may occupy the operating cab of a train while a Student Engineer is operating the train:

A. A member of the assigned Train and Engine crew (Engineer, Second Engineer, Assistant Conductor, Conductor). Train crew members may occupy the Head End only in the performance of their duties. When a Student Engineer is on the Head End, train crew members must not occupy the Head End for the purposes of qualifying on the physical characteristics.

B. An FRA/State Inspector performing an inspection.

L-S1. (Cont'd)

C. A Designated Supervisor of Locomotive Engineers evaluating a Student Engineer or assigned Engineer.

If an emergency occurs that requires a person not in one of the above categories to ride in the operating cab while a Student Engineer is in training, the Student Engineer must not be permitted to operate the train.

(4) Number of people in Cab

No more than four people, including the operating crew, are permitted to ride in the operating cab or compartment of any locomotive, control car or multiple unit train.

Exceptions to this policy are permitted when authorized specifically by the System General Road Foreman's Office for situations such as testing, special trains and unusual operating conditions.

(5) Employees in Cab

Employees are permitted to ride the head end only in the performance of their duties. They must at all times remain vigilant for signals and conditions ahead and must not interfere with the Engineer's vigilance.

Any person **not** qualified on **any** operating rules must not occupy the head end without being accompanied by a qualified supervisor.

Deadheading employees are prohibited from riding in the operating cab of trains.

A. Prior to boarding locomotive, the authorized rider must:

1. Identify himself/herself to the Engineer. The Engineer will inform the Conductor of his/her presence in the cab.
2. Present the Head End Authorization for inspection.
3. State the purpose of riding.
4. State qualifications (i.e. Operating Rules, Physical Characteristics).

B. While in the operating cab, the authorized rider must:

1. Not distract the engineer from the performance of his/her duties. There must be no unnecessary conversation.
2. Wear safety glasses and proper footwear.
3. If qualified on the Operating Rules, call signals affecting the movement of the train.
4. If qualified on Physical Characteristics, remind the Engineer of temporary restrictions when required by Operating Rules or Special Instructions.

L-S2. AMTRAK EMPLOYEE PHOTO IDENTIFICATION

All Amtrak employees are required to wear proper photo identification above the waist on their outermost garment, so that it is visible at all times while on Amtrak property. Individuals without proper identification must be promptly reported to the proper authorities.

M-S1. SUNGLASSES

Employees must not wear sunglasses at night, or under other low light conditions.

Q-S1. PAPERLESS TIME TICKET (PTT) SYSTEM

1. **Certifying Hours of Service Information:** The Hours of Service law requires governed employees to certify their hours of service information. At locations where Train and Engine service employees are required to submit their payroll time electronically using the "Paperless Time Ticket" system (PTT), the requirement to certify the hours of service information entered is fulfilled through the use of the reporting employee's user name and password as an electronic signature.

Q-S1. (Cont'd)

2. Reporting Manual Edits to Relieved/Released Time – Advertised Amount of Tie-Up Time Exceeded:

Both the PTT and Crew Dispatching Systems receive near real-time train status information to monitor employee hours-of-service. While the PTT System uses this information to pre-populate the data entry fields on the “Service Ticket” and “Hours of Service Record” screens, manual changes or corrections may not be immediately updated to the Crew Dispatching System.

To ensure Crew Dispatchers have accurate real-time hours-of-service information regarding statutory rest requirements and employee availability, employees must contact Crew Management prior to the start of their statutory rest period to report any manual edits made to the pre-populated “SignOff Time” or “Relieved/Released Time” as follows:

- For Amtrak, MARC and CDOT Revenue Trains – Manual edits that are the result of any delay or additional service after the actual arrival of the train must be reported to crew management, i.e. the advertised amount of Tie-Up time is exceeded.
- All Other Assignments – Any manual edits made to the “SignOff Time” or “Relieved/Released Time” must be reported to crew management.

Q-S2. T&E CREWS IN QUALIFICATION STATUS

a. New Hire or Re-entry Class: All Train & Engine employees who have completed New Hire or Re-entry class and are qualifying on the train will be assigned an extra board training symbol. Field management will establish the training schedule for qualifying employees and will send it to Crew Management.

All time tickets for qualifying employees must include sign up time and date, sign off time and date, train numbers and city pairs, and must show deadhead trips and statutory rest periods. Qualifying employees will be required to call CMS and have their jobs modified by the crew dispatcher whenever their assignment has changed, such as when:

- (1) You deadhead home instead of working,
- (2) You qualify on a different train, or
- (3) Your turn point changes.

Qualifying employees must mark off and mark up in the same timely manner as they would for training, personal days, vacation days, or other Company related activities. Vacations must be arranged through your vacation coordinator. Employees attending class must mark off and mark up accordingly.

b. Physical Characteristics Qualification Rides: Hours of Service governed employees who ride the head end of a train to learn or retain physical characteristics must ensure that this activity does not result in an Hours of Service violation under the covered or commingled service provisions of the Hours of Service Act.

- (1) Time spent qualifying is “covered service” and must be counted toward an employee’s total time on duty if:
 - A qualifying engine service employee operates the train’s controls, or
 - Any qualifying employee performs the duties of a member of the crew.
- (2) Any other time spent qualifying is “commingled service” and must be counted toward an employee’s total time on duty if it is not separated from covered service by a statutory off duty period.

Note: Engineers are prohibited from operating the controls of an engine unless they’re currently qualified on the physical characteristics, or have passed a pre-qualifying physical characteristics test for the portion of the railroad over which they are to operate.

Qualifying employees must contact Crew Management and their supervisor to ensure that both have accurate information regarding the start and end times of their physical characteristics qualification activity, and whether that activity was separated from covered service by a statutory off duty period.

Q-S3. HOURS OF SERVICE: EMPLOYEE RESPONSIBILITIES

1. Prior to accepting an assignment from Crew Management Services, hours of service governed employees must verify the following information with the Crew Dispatcher to ensure an hours of service violation will not result:
 - The date on which the employee's current 14 day series began.
 - The most recent non-start day within the 14 day series (the day on which an on-duty period was not initiated, if any).
 - Whether the employee has worked a Type 2 assignment since the most recent non-start day.
2. If an employee incurs delay during an assignment and will not be available to work their next scheduled assignment due to rest required by the Hours of Service law, the employee must notify Crew Management prior to the start of their statutory rest period.
3. Employees must complete service time tickets and the concurrent Hours of Service records within 72 hours upon arrival at their home crew base from that duty tour.

R-S1. EMPLOYEE PHYSICAL EXAMINATIONS

In order to remain qualified for work, employees in the following positions are required to pass a regular periodic, and when required, a special periodic physical examination:

Passenger Conductors, Assistant Passenger Conductors, Conductors, Assistant Chief Dispatchers, Dispatchers, Yardmasters, Load Dispatchers, Power Directors, Block Operators, Employees who operate self-propelled on track vehicles and others as may be directed by their immediate supervisors.

NOTE: For specific information regarding Engine Service employee physical examination requirements, refer to the applicable System General Road Foreman Notice.

NOTE: For additional information regarding Train Service employee physical examination requirements, see section "c" below.

a. Regular Periodic Physical Examinations are required every 3 years.

b. Special Periodic Physical Examinations must be completed as frequently as deemed necessary in the judgment of Amtrak Medical Services, as directed when returning from furlough, illness, accident or injury, and at other times as directed. This includes employees who have specific medical conditions which may require more frequent monitoring.

Employees are personally responsible for obtaining a medical form (MED-1) from their immediate supervisor, who will provide them with the name and phone number of the examining clinic. Employees are responsible for scheduling their own appointment with a clinic. Employees are also responsible for ensuring that the physical examination appointment does not result in an Hours of Service violation under the commingled service provision of the Hours of Service Act (appointment must be separated from covered service by a statutory off duty period).

Except as noted below for Conductor Certification, regular periodic physical examinations must be completed no later than the last day of an employee's birth month. If the employee is not currently in compliance with this requirement, or cannot meet this requirement in the future, the employee must notify Amtrak Medical Services at 215-349-2389 of the employee's inability to comply prior to the last day of the employee's birth month, and may be given a one-time extension of no more than 30 days.

R-S1. (Cont'd)

If an employee does not pass the regular or special periodic physical examination, the employee will no longer be medically qualified to work. Return to service is dependent upon elimination or correction of any medical issue(s) and/or timely response to any request for follow-up information from Amtrak Medical Services. Employees who fail to respond to such requests within the prescribed timeframe, or who fail to meet the periodic physical examination requirements, will no longer be medically qualified to perform service.

All employees must immediately report any Medical restrictions and/or medications which may affect performance by faxing a bona fide doctor's note or completed Form 3133 (Authorization to Work with Medication(s)) to Amtrak Medical Services at 215-349-4401 (Fax).

c. Additional Requirements For Employees Covered By 49 CFR 242 - Conductor Certification:

As a condition of employment and to maintain Conductor Certification, **in the year of certification or recertification, Passenger Conductors, Conductors and Assistant Conductors** must have satisfactorily completed a periodic physical examination no more than 450 days before the date of the certification or recertification decision. Further, Certified Passenger Conductors and Conductors who do not meet the vision or hearing acuity standards outlined in 49 CFR Part 242 will no longer be medically qualified to perform service until such time as Amtrak Medical Services has determined that the minimum standards of hearing and vision acuity required by 49 CFR Part 242 have been met.

In addition to the foregoing, as a condition of employment and maintaining certification, each certified Passenger Conductor and Conductor, as well as Assistant Conductors, must immediately notify Amtrak Medical Services if their best correctable vision or hearing has deteriorated to the extent that the individual no longer meets the minimum standards of hearing and vision acuity required by 49 CFR Part 242. Further, Certified Passenger Conductors, Conductors and Assistant Conductors will no longer be medically qualified to perform service until such time as Amtrak Medical Services has determined that the minimum standards of hearing and vision acuity required by 49 CFR Part 242 have been met.

R-S2. PHYSICAL EXAMINATIONS: NON-AMTRAK EMPLOYEES

Train and Engine Service employees of other railroads who operate over Amtrak Territory will be governed by the Medical examination policy of their employing railroad company. Any restriction because of a medical condition must be recorded on the qualification for service page of the current Amtrak Timetable along with other required information.

T-S1. ATTENDANCE POLICY

Amtrak agreement-covered employees will be governed by the "National System Attendance Policy for All Amtrak Agreement-Covered Employees." Copies of the policy are available at all Human Resources Department offices.

1-S1. PASSENGER CREWS IN TURNAROUND SERVICE

Passenger crews in turnaround service must re-sign the register and check the bulletin board when the actual time between trips exceeds 30 minutes.

EXCEPTION: – Conductors and Engineers in turnaround service between New York and New Haven, and between New York and Albany/ Rensselaer must re-sign the register and check the Bulletin Board before starting each trip, regardless of time elapsed between trips.

1-S2. BULLETIN ORDERS, NOTICES & GENERAL ORDERS

Summary & Non-Summary Bulletin Orders:

Bulletin Orders will be issued on a once-a-week basis, effective 12:01 AM each Monday. Bulletin Orders are numbered consecutively according to the current edition of the NEC timetable, and prefixed according to the operating territories listed in the table below. For example, a Northeast Summary Bulletin Order would be titled NE5-xxSUM, and a New York - Washington non-Summary Bulletin Order would be titled NYW5-xx, etc.

1. Summary Bulletin Orders: The Bulletin Order issued on the first Monday of each month will be a Summary Bulletin Order. Summary Bulletin Orders will contain all current information, and their numbers will be suffixed by the letters "SUM." Summary Bulletin Orders will remain in effect until the next month's Summary Bulletin Order is issued.

2. Non-Summary Bulletin Orders: Non-Summary Bulletin Orders will be issued on all Mondays except the first Monday of each month. Non-Summary Bulletin Orders will contain information issued after the Summary Bulletin Order. Each new Non-Summary Bulletin Order will supersede the previous Non-Summary Bulletin Order, and will contain all current information issued after the Summary Bulletin Order, unless otherwise specified.

Employees must retain a copy of the current Summary Bulletin Order, and the most recent Non-Summary Bulletin Order.

Employees must carry Bulletin Orders for the Lines on which they are subject to performing service. The table below shows the Lines covered by each Bulletin Order:

Bulletin Order	Applies to Crews Working Between	Lines Governed
Northeast (NE)	Boston and New York	NHB, NYT, NYS, MRS, DB, MM
Hudson (HU)	Albany and New York or Boston	HUD, NYT, PRB, NGB, NHB: Cove - Boston (South Station) only.
New York - Washington (NYW)	New York and Washington	NYP, NYT, NYS, HUD: "A" to "CP 12" only, PW, LLC, 36SC, WT, PH

Information pertaining to NYT, NYS, and certain portions of the HUD and NHB Lines is published in multiple Bulletin Orders and Notices to minimized the number of documents crews working in certain territories are required to carry.

3. Supplemental Bulletin Orders:

Supplemental Bulletin Orders will be issued when required. They will contain information that is supplemental to the current Bulletin Order. The following applies to Supplemental Bulletin Orders.

A. Employees must carry Supplemental Bulletin Orders for the lines on which they are subject to perform service.

1-S2. (Cont'd)

- B. The Line(s) affected by the information in the Supplemental Bulletin Order will be indicated at the top of the document.
- C. The number of any Supplemental Bulletin Order in effect and the Lines affected will be listed at the top of the current TSRB. Examples for each dispatching office include:
 - 1) Boston Dispatching Office: NE5-xx-a (NHB Line);
 - 2) New York Dispatching Office: HU5-xx-a (HUD Line), NYW5-xx-a (NYP Line), NYW5-xx-b (NYT Line);
 - 3) Wilmington Dispatching Office: NYW5-xx-a (PH Line).
- D. **Schedule Changes:** Supplemental Bulletin Orders that contain schedule changes applicable only to a specific bulletin order territory will be designated by the suffix "SCH" following the number of the bulletin order they supplement and an identifying letter, e.g. NYW5-58SCH-a.

4. Notices:

A Notice is a publication issued by the designated officer which contains instructions or information affecting individuals governed by the Northeast Corridor Employee Timetable. Notices contain instructions or information that does not affect the movement of trains.

Notices will be issued when required, but will be summarized monthly. Summary Notices will be effective at 12:01 AM on the first day of each month, and their numbers will be prefixed by the letter "S."

Employees must be familiar with Notices as listed below:

Notice	Lines Governed
Northeast	NHB, NYT, NYS, MRS, DB, & MM
Hudson	HUD, NYT, PRB, NGB, & NHB: Cove-Boston (South Station) only
New York - Washington (NYW)	NYP, NYT, NYS, HUD: "A" to "CP 12" only, PW, LLC, 36SC, WT, PH

A General Notice (GN) is a publication issued by the designated officer which contains instructions or information affecting Amtrak employees not governed exclusively by the Northeast Corridor Employee Timetable, and which does not affect the movement of trains.

General Notices will be issued when required. All Amtrak employees, **except those who are governed exclusively by the Northeast Corridor Employee Timetable**, must be familiar with the General Notices.

Summary General Notice numbers will be prefixed with an "S," and will contain all instructions in effect as of the effective date. They will supersede the previous Summary General Notice and all other General Notices, unless otherwise specified. General Notice(s) in effect will be indicated on the Bulletin Order.

5. General Orders:

Northeast Corridor Regional General Orders will be issued as needed, and will contain information relating to rules, procedures, or other instructions affecting the movement of trains. All Amtrak employees, **except those who are governed exclusively by the Northeast Corridor Employee Timetable**, will be governed by Regional General Orders, unless a rule or special instruction of the railroad over which they are operating specifically conflicts with these instructions. Summary Regional General Order numbers will be prefixed with an "S," and will contain all instructions in effect as of the effective date. They will supersede the previous Summary Regional General Order and all other Regional General Orders. Regional General Order(s) in effect will be indicated on the Bulletin Order.

1-S3. METRO NORTH COMMUTER RAILROAD BULLETIN ORDERS

Amtrak Conductors and Engineers operating over Metro North Commuter Railroad property must have a copy of all current Metro North Commuter Railroad Bulletin Orders in their possession while on duty.

1-S4. TEMPORARY SPEED RESTRICTION BULLETIN (TSRB)

► **Which TSRB Governs:**

TSRB (Name)	Lines Governed
Boston Dispatching Office	<i>NHB, MRS, DB, MM</i>
Wilmington Dispatching Office	<i>PW, PH, 36SC, WT, NYP (Zoo to MP 76)</i>
New York Dispatching Office	<i>NYS, NYT, HUD, PRB, NGB, NYP (NY to MP 76), LLC</i>

The list of Supplemental Bulletin Orders at the top of a TSRB must only include documents that apply to the lines listed on that office's TSRB. For example, a Boston TSRB will not include NYT or NYS information, a New York TSRB will not include information west of MP 76 or 36SC, and a Wilmington TSRB will not include HUD, NYT or NYS information.

► **TSRB Effective Times:**

TSRB'S will be effective at **5:00 A.M.** daily. Each day's TSRB will supersede the previous day's TSRB, and contain all current information.

► **TSRB Usage and Delivery:**

Temporary speed restrictions will be issued by TSRB, except when it is more efficient to issue a restriction by Form D. TSRB's will also be used to indicate whether a Supplemental Bulletin Order is in effect on the Lines on which the TSRB applies. If one or more Supplemental Bulletin Orders are in effect, a line located near the top of the TSRB will list their number(s). If no Supplemental Bulletin Orders are in effect, the word "None" will be shown.

Employees whose duties are affected must obtain a copy of the applicable TSRB(s) when reporting for duty, and must have it with them while on duty.

TSRB will be electronically transmitted to all major sign-up locations. Crews must examine TSRB to ensure that it is current, complete, and legible. If a train originates at a location where TSRB is not available, the crew must contact the Opr or Dspr for instructions.

► **Use of Speed Signs:**

Speed restrictions must be listed in sequential order. The limits of the restriction must be designated by Timetable locations, mile post locations, signal locations, bridge numbers or catenary pole numbers.

When speed signs cannot be displayed immediately, the Dispatcher must not use portions of a mile on the TSRB, unless used in conjunction with a physical characteristic location.

► **Trains Enroute at Effective Time:**

Conductors and Engineers of trains enroute at the time a new TSRB becomes effective will be governed by the TSRB in their possession, until they receive a copy of the current TSRB. If the Dispatcher directs the crew to obtain the new TSRB at a location enroute, the crew must verify receipt with the Dispatcher.

► **Adding or Cancelling Restrictions:**

Temporary speed restrictions will be added or cancelled on the TSRB, except when it is more efficient to add or cancel restrictions by Form D. Additions and cancellations to TSRB must not be copied by an employee operating the controls of a moving train.

1-S4. (Cont'd)

When dictating or repeating changes to TSRB, employees must pronounce numerals digit by digit. Only authorized abbreviations may be used in TSRB.

When a restriction is to be added, the Dispatcher, or Operator when authorized by the Dispatcher, must dictate the restriction to the Conductor, Engineer or other qualified employee on the affected train. The receiving employee must copy the additional restriction in the space provided on the TSRB. (**Note:** Additional restrictions may be written on the reverse side of the TSRB, if all space provided on the TSRB has been filled.)

When a restriction is to be cancelled, the Dispatcher, or Operator when authorized by the Dispatcher, will advise the Conductor, Engineer or other qualified employee on affected trains as to which restriction(s) must be deleted.

Additional restriction(s) or cancellation information must be correctly repeated to the Dispatcher or Operator before "time effective" or "time canceled" is given. When giving the "time effective" or "time canceled", the Dispatcher or Operator must state his initials. The receiving employee must copy the time and initials in the space provided on the TSRB, then repeat the "time effective" or "time canceled" and the Dispatcher's or Operator's initials.

The Dispatcher or Operator must acknowledge that the time and the initials were repeated correctly before the addition or cancellation may be acted upon. After the cancellation time and initials have been acknowledged, the receiving employee must draw a line through the affected restriction(s). If communication fails before "time effective" is received, the train must not proceed until communication has been reestablished.

When a speed restriction addition or cancellation is given to more than one train, the "time effective" or "time canceled" will be the same for all trains, and will be the time of the original addition or cancellation.

▶ ***Blocking Device Protection for TSRB Additions***

When a TSRB addition is to be delivered at a location where crews are not required to call for orders, the Dispatcher must apply blocking devices to ensure that the train does not depart without the TSRB addition. These blocking devices must not be removed until the addition has been delivered or until the Engineer has acknowledged that he is to receive a TSRB addition.

If the TSRB addition applies within 3 miles of the point of delivery, the train must be stopped. The TSRB addition must be delivered before the signal to proceed is displayed, unless the Engineer has been fully advised of the situation.

▶ ***Effective Period of Added Restrictions:***

Speed restrictions added to a Boston Dispatching Office TSRB remain in effect until cancelled. Speed restrictions added to New York or Wilmington Dispatching Office TSRB's will be in effect for the initial move *only*, and must be deleted (crossed out) when passed.

▶ ***Dictation to Other Affected Employees:***

The receiving employee must dictate addition or cancellation information to affected crew members before that information must be acted upon. When addition or cancellation information is relayed between employees, the dictating employee must follow the procedure outlined above for Dispatchers.

▶ ***Relieved Enroute, or Tour of Duty Ends at Outlying Point:***

When a Conductor or Engineer is relieved enroute, or their tour of duty ends at an outlying point, the TSRB must be delivered to and discussed with the relieving Conductor or Engineer. When physical delivery is impractical, the Conductor or

1-S4. (Cont'd)

Engineer must leave a copy of the TSRB in the operating compartment of the controlling engine. When the Conductor or Engineer of the relieving crew is unable to communicate with the crew they are to relieve, a member of the relieving crew must contact the Dispatcher to ensure they have received all current information before proceeding.

► **Retention of TSRB:**

Upon completion of their tour of duty at other than an outlying point, Conductors and Engineers may discard their copy of the TSRB. **EXCEPTION:** When restrictions have been added or cancelled enroute, the last employee to possess the modified TSRB must retain it for 7 days.

► **Corrections to TSRB:**

When errors are discovered in the TSRB after the faxing process has begun, the error must be corrected by Form D, or TSRB addition or cancellation. When two or more TSRB's with conflicting restrictions are faxed to recipients, a Form D Line 13 must be issued as follows:

For addition:

If not contained in your (DISPATCHING OFFICE) TSRB effective 5:00 AM (DATE) Speed Restriction (LINE) between/at _____ on ___ Trk _____ MPH Psgr _____ MPH Frt Speed signs (IN/NOT IN) service

For cancellation:

If contained in your (DISPATCHING OFFICE) TSRB effective 5:00 AM (DATE) Speed Restriction (LINE) between/at _____ on ___ Trk _____ MPH Psgr _____ MPH Frt is cancelled.

1-S5. OPERATIONS STANDARDS UPDATES & OPERATIONS SERVICE ADVISORIES

Operations Standards Updates (OSU's) and Operations Service Advisories (OSA's) are issued by Operations Support, and are available at crew sign-up locations.

OSU's modify the contents of the Service Standards Manual. Affected Train Service, OBS and Stations employees must read and comply with OSU instructions, and must retain a copy of each OSU while on duty. OSU's remain in effect until they are incorporated into the Service Standards Manual as permanent revisions.

OSA's provide Train Service, OBS and Stations employees with information regarding the delivery of Amtrak service. OSA's are general in nature, or temporary in scope. Employees must read and comply with OSA's, but need not retain them while on duty. OSA's do not modify the contents of the Service Standards Manual, but remain in effect until fulfilled or cancelled.

OSU's and OSA's will be numbered sequentially, the number being prefixed by the last two digits of the current year. The number of the most recent OSU and OSA will be indicated on the train manifest. (*See SI 4-S1, page 273*)

1-S6. EMPLOYEE REGISTERS

Employee Registers are in service at all major crew sign up locations. Employees reporting for duty must examine the Bulletin Board or Bulletin Book, then sign the Employee Register.

2-S1. STANDARD TIME

Eastern Standard Time applies.

Effective 2:00 A.M. on the second Sunday of March, Standard Time must be advanced one hour. This is Daylight Saving Time.

Standard clocks must be advanced one hour at 2:00 A.M., and time changed to 3:00 A.M., Standard Time. Employees advancing standard clocks must, as soon as the change has been made, compare time with the Dispatcher.

Offices where standard clocks are located, which are not open at 2:00 A.M., must advance clocks one hour at time the office is opened and compare time with the Dispatcher.

Effective 2:00 A.M., on the first Sunday of November, Standard Time must be set back one hour.

Standard clocks must be set back one hour at 2:00 A.M., and time changed to 1:00 A.M., Standard Time. Employees setting back standard clocks must, as soon as the change has been made, compare time with the Dispatcher.

Offices where standard clocks are located, which are not open at 2:00 A.M., must set back clocks one hour at time office is opened and compare time with the Dispatcher.

When time changes, employees who are required by Rule 3 to use a reliable watch and are on duty when time changes, must adjust their watch as soon as possible without incurring delay to train movements. Employees must compare their watch with a standard clock or secure time from the Dispatcher as soon as practical after time changes. Employees who have access to an ATS phone can call the Naval Observatory Master Clock at (ATS) 777-4000 or (202) 906-4000 to obtain correct time.

4-S1. JOB BRIEFING

Amtrak train and engine crew members must hold a job briefing at the beginning of their tour of duty and each time operational or safety conditions change after the initial job briefing.

Non-Amtrak crews are required to conduct a job briefing prior to entering Amtrak property and each time operational or safety conditions change after the initial briefing.

Amtrak Conductors are required to use the **Initial/En Route Job Briefing Checklist form (NRPC 3243)** or **Initial Job Briefing Checklist for Yard Crews form (NRPC 3272)** during their initial job briefings, and must retain it for inspection for five days. All applicable portions of the form must be reviewed and filled out to ensure that all safety critical information, all tasks to be performed, and each crew member's individual responsibilities are communicated to all members of the train crew. The Conductor is responsible for ensuring that all on-train employees participate in a job briefing, and for noting the name, date and time employees were briefed. On Board Service Employees who are on down time are not to be disturbed while at rest period.

A note must be added to the back of the Initial Job Briefing Checklist form whenever an additional job briefing is conducted. When the Conductor is relieved en route, the relieving Conductor must sign the form and add the date and time that all pertinent briefing subjects have been discussed with all affected crew members.

Job briefings must cover the following types of information, if applicable.

1. Bulletin Orders, TSRB's & Form D's: The Conductor, Engineer and any Assistant Conductor who is a certified Conductor must ensure they have a copy of all current Bulletin Orders in effect for the territory over which their train will operate. The Conductor and Engineer must also ensure they have a copy of all TSRB's, and Form D's in effect for the territory over which their train will operate. Crew members must discuss with each other all new and temporary restrictions that may affect their train's movement or their duties.

4-S1. (Cont'd)

2. General Orders, System General Road Foreman Notices, Operations Standards Updates & Advisories: If a General Order, System General Road Foreman Notice or Operations Standards Update has been issued within the last five days, the Conductor and Engineer must ensure that all affected crew members have a copy of each applicable item.

They must discuss with other crew members all new instructions and Operations Standards Advisories that may affect their duties, including operating rule of the day, if applicable, and customer service tip of the day.

3. Equipment Restrictions (See S.I. 34-S4, pg 279): The Conductor and Engineer must discuss with other crew members the type of equipment they are likely to have in their train, the status of required air brake tests and MAP forms, if known, and the maximum speed and other restrictions associated with the equipment. If a train manifest is available, the Conductor must give the Engineer a copy. The Conductor must review the actual consist before departure. If the equipment is more restrictive than originally discussed, the Conductor must inform all crew members of the additional restrictions.

4. Safety and Security: The Conductor and Engineer must ensure all crew members are in possession of applicable personal protective equipment such as safety vests, safety glasses, gloves, proper footwear, etc. All crew members must:

- a. Discuss any known or potential safety hazard, including weather conditions that the crew or passengers may encounter during the crew's tour of duty, and the actions that crew members will take to avoid the hazard.
- b. Look up and discuss the safety instruction of the day.
- c. Review security and emergency procedure-related information, including availability of on-board emergency tools.
- d. Ensure compliance with hours-of-service limitations and that all crew members are properly rested.
- e. Ensure compliance with proper use of electronic devices.
- f. Proper identification for border crossings.

5. Correct Time: The Conductor must set his watch with a standard clock or time service, and must ensure that the watches of other crew members indicate the correct time. Conductors who have access to an ATS phone must call the Naval Observatory Master Clock at (ATS) 777-4000 or (202) 906-4000 to obtain the correct time.

6. Passenger Service: Crews in passenger service must discuss the following additional items:

- a. The scheduled station stops for each trip, including any special requirements.
- b. Any private cars or groups that will be handled.
- c. Who will work which cars.
- d. Who will examine platforms leaving stations, in accordance with SI 940-S1, page 359.
- e. Who will make train announcements.
- f. Who will be responsible for door operation in accordance with SI 940-S1, page 359.

7. Yard Service: Crews in yard service must discuss the following additional items:

- a. The specific jobs to be done or moves to be made, and each employee's associated responsibilities.
- b. The means of communication that will be used to control the movement.
- c. Who will be responsible for securing equipment that will be left unattended.
- d. If a back-up hose will be required, who will be responsible for connecting and testing the device.

4-S1. (Cont'd)

8. Reporting Clear or Releasing Main Track Authorities: All crew members are jointly responsible, through job briefing, to ascertain and agree on the exact location that their entire train has passed before reporting past a specific point or clearing a main track authority (Form D).

9. Securing Unattended Equipment: : All crew members are jointly responsible for the location and proper securement of any equipment left unattended. Crew members must review information relevant to securing the equipment before, during and after the securement process. Information that must be reviewed includes:

- a. In yards, location where equipment is to be left to ensure it will not foul an adjacent track.
- b. Type of equipment to be secured, such as cars only, locomotives only, or cars and locomotives, and the amount, type and location of any cars containing hazardous materials.
- c. Number of handbrakes applied to secure the equipment, and number and location of chocks, if used.
- d. Means of testing to verify that securement measures are effective.
- e. Responsibilities of each employee involved in securing the equipment, including the identification of the crew member who will report the securement of equipment left standing on a mainline track or mainline siding to the train dispatcher.
- f. Any other relevant factors affecting securement.

10. Designated Job Briefing Locations

Train and Engine service employees must conduct their job briefing at the beginning of their tour of duty at the following locations:

LOCATION	CONDUCT JOB BRIEFING IN:
All Locations	
Work Train Crews Reporting for Duty at Outlying Points	Locomotive at the starting point of assignment
Washington to Philadelphia and Philadelphia to Harrisburg	
Washington Terminal ▶ Road Crews	Crew Dispatcher's Office, Transportation Building
Washington Terminal ▶ Yard Crews	Station Sign-Up - Assigned locomotive, or yard crew room in Track 7 Terminal Service Building Coach Yard Sign-Up - Assigned locomotive, or Coach Yard Building
Martins MARC Facility	T&E crew room
Odenton MW Base	T&E room, second floor
Baltimore Station	T&E room, basement
Perryville MW Base	T&E room, first floor
Wilmington Shops	T&E room, building 23, adjacent to backshop
30th Street Station, Philadelphia	Sign-up room across from T&E lounge, adjacent to valet parking window.
Race Street Engine House	T&E locker room, second floor
Lancaster Station	MW locker room
Harrisburg Station	T&E lounge

4-S1. (Cont'd)

New Jersey to Boston and St. Albans

Adams MW Base	Cafeteria
Penn Station, NY	Job Briefing room, NY Crewbase area adjacent to main T&E lunchroom.
Sunnyside Yard	R Tower
New Haven ▶ Road and Yard crews	Ticket Receiver's Office
New Haven ▶ CDOT crews	T&E Crew Room second floor CDOT Maintenance Facility
Southampton Street ▶ Yard Crews	Yardmaster's Office, Southampton Street Yard. Note: Yardmaster must be included in the job briefing.
Springfield	Crew sign-up room, Springfield station
Boston	Crew sign-up room, South Station – lower level, east wing, main corridor.
St. Albans	Crew sign-up room, St. Albans station

4-S2. CONDUCTOR PILOT JOB BRIEFING: TRACK CARS

A Conductor assigned to pilot a track car must conduct a job briefing with a Road Foreman or Trainmaster before assuming duty on the track car. The employee so assigned must call the Chief Train Dispatcher to determine the Road Foreman or Trainmaster on duty. The job briefing must include a review of the operating rules and instructions applicable to the assignment, which typically include, but are not limited to rules 121(d), 162(b), 241, 605, 802, 803, 805, 807, 808, 809, 811, 812 & 815.

4-S3. CREW RESOURCE MANAGEMENT (CRM)

Crew Resource Management addresses the human element of people working together in safety sensitive conditions with highly sophisticated technology. When applied to the railroad industry, it can be seen as the effective use of all resources to achieve safe and efficient train operations.

Crew Resource Management is comprised of:

- A comprehensive system for improving crew performance.
- A process that addresses the entire crew and other related staff, such as yardmaster, dispatcher, utility employee, or a locomotive engineer performing duties as a pilot.
- A heightened awareness of attitudes and behaviors of crew members and their impact on safety.
- A forum that allows the individuals to examine their behavior and make individual decisions on how to improve teamwork.
- A focus on the function of crew members as teams, not as a collection of technically competent individuals.

Three primary tools for employees to use to achieve Crew Resource Management are:

1. Technical Proficiency
2. Situational Awareness
3. Communication and Teamwork

The following information refers to crew members but is applicable to all railroad employees working together or interacting with other crafts in the course of their duties.

4-S3. (Cont'd)

How to use Technical Proficiency:

1. Use rule classes to further your knowledge of operating rules. Ask questions to resolve conflicts where the practice does not seem to comply with the rule.
2. At any time, call Operating Practices or your manager to get an answer to your rules questions.
3. In situations where the application of a rule may not be clear to you, review the rule before taking action. Look it up and discuss it with other crew members.
4. Comply with the letter of the rule at all times. Don't assume that only a portion of the rule applies to a particular situation unless the rule clearly states so.

How to use Situational Awareness:

1. Workload distribution: Use other crew members to take some of the workload off you, especially in critical situations. Ask them to look up a rule, handle the radio, and take care of the passenger problem so you can handle the operational situation.
2. Set priorities: In some situations where there are too many tasks to perform, learn to identify and take care of the ones that are the most critical. You may not like to give up some tasks, but it is important that you know your limits and take steps to stay within them. If you are too busy to answer the dispatcher, don't.
3. Recognize deteriorating situations: If things are going from bad to worse, take time out to step back and sort it out. Stop the train, if necessary. Too many accidents have occurred because crew members could see that the situation was deteriorating but failed to do anything about it.
4. Verbalize concern: Sometimes you are the only member of the crew who recognizes a potentially dangerous situation. Let other crew members know of your concerns so that they may help develop a solution.

How to use Communication & Teamwork:

1. Set the tone for teamwork: Start with the first job briefing to demonstrate your willingness to work as part of a team. If you are conducting the briefing, encourage participation initially and as the trip progresses. If you are not conducting the briefing, participate fully, ask questions and determine what will be expected of you.
2. Use appropriate persistence: No matter what your position in the crew, speak up if you are in doubt about what is happening. Your communications with other crew members should be:
 - Timely - don't wait until it's too late.
 - Clear - if you have a specific concern, clearly state it (did we get the ABC block?)
 - Focused - important communications should be handled apart from other discussions. Ask about two different subjects - you'll usually get the answer and attention to the one of least importance.
3. Propose a solution: Nobody likes to be challenged or have a mistake pointed out. Use tact when appropriate. "Do you need help with that dual control switch?" is much better than "Don't you know how to operate that switch?"

10-S1. FUSEES

On account of fire hazard lighted fusees must not be displayed on open deck bridges, movable bridges, trestles or in the vicinity of areas where fuel oil or flammable liquids are present nor in the following territory unless necessary to prevent an accident:

- Between East Portals of East River Tunnels and West Portals of North River Tunnels.
- Between Fulton and Biddle Street.

16-S1. BLUE SIGNAL PROTECTION: T&E EMPLOYEES

Train and Engine Service employees are prohibited from operating any mechanical, pneumatic or electrical apparatus on equipment that has blue signal protection, unless specifically authorized by the person in charge of the workmen. Such authority must not be accepted unless the person giving it has clearly identified himself as the person in charge of the workmen.

16-S2. BLUE SIGNAL PROTECTION: SIGNAL LOCATIONS

The following instructions apply where Amtrak employees or contractors utilize blue signal protection:

1. On either main track or other than main track, whenever a blue signal is required to be attached to the controlling locomotive and visible to the Engineer or operator at the controls, such signal must be located on the control stand or console. Displaying a blue signal on the exterior of the locomotive, such as a blue flag attached to the Engineer's window, will **not** be considered to be readily visible to an employee at the controls.

2. On main track, whenever a blue signal is required to be placed at each end of rolling equipment, such signal must be located either at the extreme end of the equipment or in advance of the equipment. Displaying a blue signal on either side of the equipment, including a blue flag attached to the Engineer's window, will **not** be considered as being displayed at the end of rolling equipment.

Exception: This instruction does not apply at mechanical facilities under the exclusive control of the Mechanical Department, where alternate methods of blue signal protection provide full protection in compliance with all blue signal rules.

19-S1. WHISTLE or HORN FAILURES

In the application of NORAC Rule 19:

If the engine whistle or horn on the leading end of the movement fails en route, the Dispatcher must be notified and a crew member must immediately take position at the next operable forward facing horn or whistle on the train. The Engineer must be able to communicate with this employee to instruct him when to sound the required whistle or horn signals. If these conditions cannot be met, the Engineer must take the following actions until the whistle or horn is repaired:

1. Notify the Dispatcher immediately.
2. Reduce speed to not exceeding 30 MPH.
3. Ring the bell continuously, if equipped.
4. Stop before each public highway crossing at grade and provide on-ground warning until the crossing is occupied, unless:
 - a. Automatic crossing warning devices are functioning properly,
or
 - b. No traffic is approaching or stopped at a crossing not equipped with automatic crossing warning devices.

19-S2. PORTABLE WHISTLE SIGNS

Portable Whistle Signs are used by Engineering Department employees to provide Locomotive Engineers with advance warning that MW employees are working ahead. These signs have a reflective orange background, are oval in shape (1 foot wide by 2 feet high), and display a black letter “W” in the middle. They are placed to the right of affected tracks, and sufficiently in advance of the work area to provide adequate warning.

Engineers observing a Portable Whistle Sign **on any track** must sound the engine whistle or horn in accordance with Rule 19(d).

20-S1. ENGINE BELL and STROBE LIGHTS

Ring of engine bell may be omitted when running through tunnels.

EXCEPTION: Engine bell **must be rung continuously** within the confines of the Empire Tunnel and the Riverside Park Overbuild and within B&P and Union Tunnels.

Model F40PH engines and AEM-7 engines must have Signal Light Circuit breaker in service. Two WHITE strobe lights mounted on top of the operating cab will operate automatically whenever the engine bell is used.

20-S2. ENGINE BELL ON TRAINS MAKING STATION STOPS

The bell of equipped trains must be sounded when approaching a station platform where the train is scheduled to stop. The bell must continue to be sounded until the train has stopped.

22-S1. AUXILIARY LIGHTS

Engines that are equipped with strobe lights alone (i.e., no ditch lights, crossing lights or oscillating light) must not exceed 40 MPH when operating over public crossings at grade.

22-S2. DITCH LIGHT (AUXILIARY LIGHT) SWITCH

The ditch light (auxiliary light) switch facing the direction of movement on all trains and engines must be placed in the ON position at all times except:

1. While standing or passing through yards where other engines are working.
2. When approaching a station where a Form D is to be received.
3. When approaching junctions or terminals.
4. When standing or moving on a main track at meeting points.
5. When standing or when approaching another train operating in the opposite direction in multiple track territory.

When approaching or passing over public highway crossings at grade, the ditch light (auxiliary light) must not be turned off.

Note: HST's and HHP-8 locomotives are equipped with a four position ditch light (auxiliary light) switch. When the ditch lights must be displayed this four position **switch must be placed in the ON position**, not the AUTOMATIC position.

24-S1. LIGHT SENSITIVE PORTABLE MARKING DEVICES ON REAR OF PASSENGER TRAINS

Passenger trains with a non-passenger carrying car on the rear may operate with a light sensitive portable marking device that illuminates only at night or when otherwise activated by low light conditions.

PASSENGER TRAIN OPERATION

34-S1. AMFLEET, CAPITOLINER CONTROL CARS, CDOT CONTROL CARS AND SPV CARS: AIR BELLOWS

Instructions when the air bellows become over-inflated or under-inflated (deflated) are as follows:

1. When under-inflated no action is necessary except to report occurrence on Form Map 21-A.

2. When over-inflated the speed of train must be reduced (see Special Instruction 37-S5, page 298) and the air bellows deflated as soon as practicable.

Instructions to deflate the air bellows are:

- a. Locate "Air Spring Cut Out" badge plate on the car side sill (each end of car).
- b. Close both "Air Spring Supply Cocks" on end affected. The cocks are located near the badge plate, have YELLOW handles and are tagged.
- c. Open the "Deflate Air Spring Valve." It is located near the air spring supply cocks and has a RED handle.
- d. After the air bellows are deflated normal speed may be resumed.

If the car is not equipped with a "Deflate Air Spring Valve" follow instructions (a) and (b) and operate per Special Instruction **37-S5** (page 298), to next terminal. The Dispatcher must be notified as soon as possible.

34-S2. ENGINES AND EQUIPMENT EQUIPPED WITH PYRANOL COOLED TRANSFORMERS.

This instruction applies to SEPTA MU Silverliner Cars Nos. 201-239, 251-399 & 9001-9017: When debris is struck which may cause damage to the undercarriage of your train, Engineer must bring train to a safe stop and train crew must inspect above listed equipment when in consist of train to insure that no transformer is leaking.

If transformer is leaking, train must not be moved until instructions are received from General Manager's Office.

34-S3. BRAKING AT SPEEDS IN EXCESS OF 110 MPH AMTRAK PSGR EQUIPMENT

When operating at speeds in excess of 110 MPH, a full service brake application must be made whenever a reduction in speed is necessary in order to comply with fixed signal or cab signal indication. Once it is ascertained that the required speed will be affected, a lesser degree of braking may be used.

34-S4. PASSENGER TRAIN CONSIST

In accordance with Special Instruction 4-S1 (page 272), Conductors of trains operating on the Amtrak Northeast Corridor must review the consist of their train before leaving their initial terminal, at crew change locations, or before entering the Amtrak Northeast Corridor, and must have a job briefing with their Engineer and other crew members to discuss the maximum speed and other restrictions associated with their equipment.

If a car in the train is restricted to a speed less than the maximum speed of the train's normal consist, the Conductor must notify the Dispatcher, in addition to all crew members. Dispatchers notified of such restrictions must inform the connecting dispatching district.

Conductors and Engineers of passenger trains consisting of cars that are not listed in the Timetable, must not leave their initial terminal without a train manifest, Form D or Passenger Name Record (PNR) indicating the maximum speed for equipment and any pertinent movement restrictions.

34-S4. (Cont'd)

All passenger cars that are not listed in the Timetable, will be assigned a classification code letter to indicate the status for operation on Amtrak property (see SI 37-S5, page 300). The following letters indicate any restrictions:

A—No restrictions.

B—Must not operate in third rail territory between Hudson and CP 216, and between Penn Station and CP 12. Must not operate on No. 27 track south of 16RC signal in Washington Terminal.

C—May operate in Washington Terminal on all tracks, except: From H Signal Bridge to and including Station Tracks 13, 14 and 17 through 20, and on No. 27 track south of 16RC signal. Must not operate on any other tracks of the Northeast Corridor.

D—May operate in Washington Terminal on all tracks, except: From H Signal Bridge to and including Station Tracks 12 through 14, and 17 through 20, on No. 27 track south of 16RC signal, and north of K Signal Bridge on Track 42. Must not operate on any other tracks of the Northeast Corridor.

34-S5. TRAINS OPERATING IN DIRECT RELEASE

When assuming control of a train, Engineers must examine the Air Brake slip to determine whether the train is set in graduated or direct release.

AEM-7 engines must not be used to control the movement of a train that has its air brakes set in direct release, except in an emergency (e.g., the engine controlling movement of a train set for direct release becomes disabled, and the only available rescue engine is an AEM-7). In such a case, care must be taken not to graduate off an automatic brake reduction, resulting in an unintentional release of the train brakes.

Direct release trains controlled by an AEM-7 must not exceed 30 MPH between Bergen and "F" Interlockings on the NYP Line.

34-S6. BRIDGE PLATES: ASSISTING MOBILITY IMPAIRED PASSENGERS

Train crews are to assist mobility impaired passengers in getting on and off trains by using the metal **bridge plates** that are available at the stations listed below, for trains operating as indicated. Bridge plates are stored in black containers which can be opened by coach key, or are secured by chain and 102 switch key operated padlock. After use, bridge plates must be returned to their containers, and container doors locked. Train crews who find bridge plates missing, or locks or containers damaged, must inform the Dispatcher.

NHB Line: New London.

NYP Line: Newark Penn Station (trks 1 & 3); Newark International Airport (3 plates per platform, at ends of station building & center of platform); Metro Park (2 plates per platform, at ends of overhead canopy); New Brunswick & Princeton Jct. (1 plate on each platform adjacent to elevators); Trenton (2 plates on trks 1 & 4); Cornwells Heights, east & west (equipped for SEPTA & Amtrak trains).

PH Line: Exton (east & west); Bryn Mawr, Thorndale (west only).

PW Line: Churchman's Crossing, No. 1 Trk only; 30th St. Phila. (Stored at stenciled locations without containers: 2 numbered bridge plates each platform, odd numbered behind south end stairway near platform telephone location, even numbered next to blocked off stairway north of elevator).

34-S7. MARYLAND DOT CARS: TRAP DOOR OPERATION

Passenger cars MARC II series 7700-7735, 7745-7762, 7791-7799 and MARC III series 7800-7891 are provided with release levers to enable an employee on the ground to raise the trap door. Employees may use this lever for that purpose, exercising caution to prevent injury. Paragraph "f" of Safety Instruction 5314 will not apply to employees using the release lever on these cars.

34-S8. TRAINS TURNING AT THORNDALE, MARCUS HOOK OR WILMINGTON

Passenger trains turning at Thorndale, Marcus Hook or Wilmington stations may reverse back to Thorn, Hook or Wine after the home signal is seen to display a proceed indication, and the track to the home signal is seen to be clear. Movement must operate at Restricted Speed until governed by a more favorable signal.

FREIGHT TRAIN OPERATION

35-S1. FREIGHT OPERATION:

A. 6:00 AM to 10:00 PM RESTRICTION

The following trains must not exceed 30 MPH between 6:00 AM and 10:00 PM on any Amtrak dispatched line except the PH, HUD, MRS and PRB Lines: **(1)** Work trains; **(2)** Freight trains; **(3)** Light or multiple light engines.

Exceptions:

1. Equipment: This restriction does not apply to track cars, or Amtrak, MARC & NJT light or multiple light engines.

2. PW & NYP Lines: This restriction does not apply to NS solid TV trains. (A TV train is a freight train consisting entirely of equipment designed to carry trailers, containers, or RoadRailers.)

3. NHB Line: This restriction does not apply to trains that are equipped with operative on-board ACSES apparatus, and are operating in territory where ACSES Rules 580-591 are in effect.

B. Oil & Ethanol Train Restriction

The following trains must not exceed 40 MPH on any Amtrak dispatched line: (1) Trains transporting 20 or more tank cars in a continuous block which are loaded with crude oil, ethanol, or a Class 3 flammable liquid. (2) Trains containing 35 or more tank cars loaded with crude oil, ethanol, or a Class 3 flammable liquid.

35-S2. BACK UP MOVEMENTS

When backing freight trains, a minimum of three and not more than five hand brakes must be applied on rear to prevent slack running out on a descending grade.

35-S3. MAXIMUM POWER ON REAR

Helper engines pushing freight trains are limited to a total of 12 traction motors.

Helper engines pushing freight trains must ease off passing over cross-overs or turn outs when making diverging movements, exercising care to avoid slack action.

Employees are prohibited from riding in caboose while train is being pushed except when the caboose is coupled behind the helper engine.

35-S4. FREIGHT TRAIN CAR LIMIT

Freight trains must not exceed 135 cars, with the following exceptions:

1. Trains which are not equipped with operating telemetry devices and are operating without a caboose on the rear must not exceed 50 cars.
2. Trains consisting entirely of empty hopper cars, must not exceed 150 cars. (See SI 35-P1, page 210)
3. Trains consisting entirely of empty Jenny type hopper cars, must not exceed 180 cars.
4. Trains consisting entirely of TPIX (Tropicana) cars, must not exceed 65 cars.

35-S5. MINERAL TRAIN

A train containing 25% or more of cars loaded with coal (*see "Note" below*), ore, stone, sand, clay or grain will be classified as a Mineral Train. Conductor or Engineer must notify the Dispatcher or Operator that they are entering Amtrak territory with a Mineral Train. (See S.I. 37-S4, page 287, for speed.)

Note: This instruction does *not* apply to trains containing 25% or more of cars loaded with **coke**.

35-S6. CWR-RAIL TRAINS

When operating Amtrak CWR-Rail Trains loaded or empty, brake pipe pressure will be maintained and set for 110 lbs. over the entire Northeast Corridor. When the CWR-Rail Train is loaded and working without a buffer car as the rearmost car of the train, the maximum authorized speed is 20 MPH, and distance must not exceed 20 miles.

35-S7. CABOOSELESS FREIGHT TRAINS

The operation of cabooseless freight trains on the Northeast Corridor is subject to the following conditions:

1. Trains consisting entirely of trail-van equipment may operate at any hour.
2. Trains designated as local freights, yard transfers or switchers may operate at any hour.
3. Mixed or mineral freight trains may operate **only** between the hours of 10:00 P.M. and 6:00 A.M., *except*:
 - a. Mixed or mineral freight trains may operate at any hour on the PH Line between State & Glen, on the MRS Line between Mill River & Spring, and on the NHB Line between New Haven and MP 190.
 - b. Mineral freight and empty hopper trains may operate at any hour on the PW Line on Track A between Gunpow and Bay, and on No. 1 Track between Bowie and Landover.
 - c. Trains delayed while en route over the Northeast Corridor may be permitted to continue to their final terminal.
 - d. The General Manager or his representative may authorize an exception to the specified hours for a train that has been delayed on freight railroad property as a result of switch, signal, or mechanical failure.

PASSENGER AND FREIGHT TRAIN OPERATION

36-S1. TRAIN PARTINGS

- a. Whenever a train parting occurs the Conductor or Engineer must notify the Dispatcher immediately. The following information must be furnished:
 1. Location of train when parting occurred.
 2. Position in train & identification of equipment involved.
 3. Position of knuckles where parting occurred, if determinable.
 4. Distance between parted sections and whether or not any run-in following parting.
 5. Throttle position, speed, type of air applied, if any.
 6. Apparent reason for parting.
 7. Any other unusual conditions in connection with occurrence.
- b. Inspect the coupler and coupler operating mechanism. Check that coupler is in level position on the coupler carrier and that coupler operating mechanism is in good condition and operating freely.
- c. Remove any dirt, debris, ice, etc., from inside the coupler head. Close knuckle and observe that the rotary locklift is clear and coupler indicates that it is properly locked.
- d. If satisfied that coupler is locked, leave knuckle closed on suspect coupler. Open the knuckle on the mating coupler and couple cars together.
- e. After coupling, signal Engineer to stretch the train, then take slack and make a second stretch with the engine.
- f. **If separation was between two passenger carrying cars, a train crew member must be stationed in vestibule to prevent passenger movement between cars.**
- g. Whenever inspection reveals any coupler defects or improper couplings that cannot be corrected, the equipment involved must be set out.
- h. If inspection does not reveal any coupler defects and all pins appear to be in locked position, proceed to the next station where mechanical forces are on duty to inspect and make any emergency repairs that are necessary. If a locking pin had been applied to the rotary lock lift, replace the pin if possible.
- i. *If a second separation occurs between the same equipment, the equipment involved must be set out.* Inform the train dispatcher that the same equipment has separated for the second time and be governed by instructions received regarding location where car(s) are to be set out.

Exceptions: If an open knuckle was discovered on the same car in both separations, only that car must be set out. Or, if setting out one car leaves the suspect knuckle of the remaining car at the extreme rear of train, that car may move in the train as long as no other equipment is coupled behind it.
- j. Complete Unusual Occurrence Report and appropriate MAP forms/IDRS.

36-S2. RESTRICTED SPEED OPERATIONAL TEST

In an effort to ensure that trains required to operate at Restricted Speed are able to stop short of an obstruction, Amtrak Supervisors conducting operational tests will be placing a Temporary Track Barricade Sign in the gauge of the track ahead of trains *which are required by rule or special instruction to operate at Restricted Speed*. There are two types of Temporary Track Barricade Signs:

Type 1: An octagonal reflectorized red metal sign which has the word “Barricade” stenciled on it in white letters:



Type 2: This sign consists of 2 sections: The lower section is approximately 3 feet in height, is outlined in yellow, and displays 4" wide orange and white diagonal stripes made from reflectorized material. The upper section consists of a red pipe with two angled brackets which hold red flags. A 7" red flashing strobe light is mounted at the top of the pipe, and is shaded by a yellow sun visor:



36-S3. MAIN TRACKS

In the application of Rules 14 and 136, all tracks that are governed by Interlocking, ABS or DCS Rules are considered Main Tracks.

36-S4. MATERIAL HANDLING CARS

Amtrak Material Handling Cars, Series 1500-1569 must not be moved unless doors are properly closed and secured.

36-S5. TRAINS PERFORMING BAGGAGE OR MAIL WORK

When a train is to perform baggage or mail work, the Conductor must have a job briefing with all crew members to confirm each individual's responsibilities regarding the baggage or mail work.

The Conductor must ensure that all baggage or mail work is completed and doors are secure before authorization is given for the train to proceed. The Conductor must not rely on information from non-crew members to determine when the work is complete and doors are secured. The Conductor (or other designated crew member) must make this determination through direct visual observation.

Permission to proceed must only be given verbally or by hand signal. At locations where baggage or mail work is performed, the Engineer must not accept the communicating signal as authority to proceed.

36-S6. RWP FLAGS AND TAGS

RWP flags and tags are used in conjunction with certain Roadway Worker Protection (RWP) safety procedures. An RWP flag is a reflectorized orange flag with black letters "RWP." An RWP tag is a fluorescent orange tag with the words "RWP PROTECTION. DO NOT REMOVE" on one side, and "DO NOT REMOVE. EMPLOYEE AT WORK" on the reverse side.

RWP flags are erected at derails applied to prevent entrance to track segments fouled by Roadway Workers, to make the derail more visible to approaching trains.

RWP tags are fastened to locks or other securing devices applied to switches or derails positioned to prevent entrance to track segments fouled by Roadway Workers, to prevent unauthorized employees from removing the securing device.

RWP tags are also attached to the controls of unattended engines that are located within a track segment fouled by Roadway Workers, to prevent unauthorized movement. Engines with an RWP tag attached to the controls must not be moved.

RWP flags and tags may be removed only by the Roadway Worker in charge of the working limits, or by another Roadway Worker who has been authorized by the Roadway Worker in charge of the working limits.

36-S7. HAULING DEAD ENGINES

a. Position in Train: Engines equipped with draft gear hauled "dead" in a train should be placed next to the hauling engine. Under no circumstances may they be placed further than 35 cars from the hauling engine.

b. Coupler & Brake Requirements for Consecutive Coupling: Each engine unit must be counted as a car. Engine units must be separated by one or more cars with operative air brakes unless it is known that:

1. Engine units are equipped with alignment control couplers,
AND
 2. The air brake equipment on each unit incorporates a brake valve vent.
- The engines may be coupled consecutively if these conditions are met.

36-S8. OPERATING THROUGH WATER WITH ROLLER BEARING JOURNALS

Engines and cars equipped with roller bearing journals must not be operated through water, except in an emergency when authorized by the Dispatcher. In such a case, the movement must not exceed 2 MPH, and water depth as measured from the top of the rail must not exceed the following:

EQUIPMENT TYPE	WATER DEPTH
Non-NJT Electric Engines, Classes AEM-7, ALP-46 & ALP-44	6 inches
NJT Electric Engines Classes ALP-46 &ALP-44	3 inches
ACS-64, HST & HHP-8	4 inches
Other Electric Engines and MU Cars	2 inches
NJT P-40BH Diesel Engines	2.5 inches
Other Diesel Engines	3 inches
Rail Diesel Cars; Cars Other than MU's	7 inches

**36-S9. AMT-3: AIR BRAKE AND TRAIN HANDLING RULES AND INSTRUCTIONS:
5.1.10 TRAIN BRAKING**

Instruction 5.1.10, paragraph B revised to change section 5.2.4 to 5.2.5:

B. Trains Other Than Mixed Consist - The procedures outlined in Section 5.2 will be used to slow or stop Trains Other Than Mixed Consist. When operating electric locomotives, do not use the procedures in Section 5.2.4 5.2.5 unless dynamic brake is inoperative.

**36-S10 AMT-3: AIR BRAKE AND TRAIN HANDLING RULES AND INSTRUCTIONS:
9.2.3 LOCOMOTIVE & EQUIPMENT MAXIMUM SPEEDS**

The following equipment in AMT-3 9.2.3 is revised as shown:

Engine No.	Bldr. Model	Speed MPH			Bldr
		Lite	Mltp Lite	With Train	
550-567	SW1200	30	45	50	EMD
597, 599	2GS12B	30	45	50	NRE
600-670**	ACS-64	50	50	125	SIE
680-694**	HHP-8	50	50	125	ABC
900-953**	AEM-7	50	50	125	EMD

Equipment	MPH
Dome lounge 10031	110
Viewliner I Cars 62000-62090, 8400	110

SPEEDS—MAXIMUM AND VARIOUS

37-S1. SPEED TABLE

Engineers of trains that will operate at speeds greater than 20 MPH must verify the accuracy of the speedometer as soon as possible after departure. If the speedometer is not accurate to within plus or minus 3 MPH at speeds of 10 to 30 MPH, or to within plus or minus 5 MPH at speeds above 30 MPH, Engineers must verbally report the variance to the Dispatcher as soon as practical, and must note the variance on the prescribed form.

TIME PER MILE		MILES PER HOUR	TIME PER MILE		MILES PER HOUR
MINS.	SECS.		MINS.	SECS.	
0	24.0	150	0	48.0	75
	24.8	145	0	51.4	70
	25.7	140	0	55.4	65
	26.7	135	1	00	60
	27.7	130	1	5.5	55
0	28.8	125	1	12	50
0	30.0	120	1	20	45
0	31.3	115	1	30	40
0	32.7	110	1	43	35
0	34.3	105	2	00	30
0	36.0	100	2	24	25
0	37.9	95	3	00	20
0	40.0	90	4	00	15
0	42.4	85	6	00	10
0	45.0	80	12	00	5

37-S2. ENGINE SERVICING TRACKS AND CAR SHOP REPAIR TRACKS

Movements on Engine Servicing Tracks or Car Shop Repair Tracks must operate at Restricted Speed, not exceeding 5 MPH.

37-S3. TURNOUTS AND CROSSOVERS

All hand-operated crossover and turnouts:

Diverging movements 10 MPH

Non-interlocked crossovers and turnouts:

Diverging movements 10 MPH

37-S4. SPECIAL MAXIMUM SPEEDS

EQUIPMENT	MPH
Circus Trains	30
Freight and work trains handling machinery of rotary or swinging type, such as cranes, derricks, steam shovels, etc., moving on own wheels	
on straight track	30
on curves	20
Mineral Freight Trains	30
(See Special Instruction 35-S5, page 282)	
(NHB Line)	
“Providence & Worcester” Mineral freight Trains between New Haven and Boston	40
(PH Line)	
Mineral Freight Trains Eastward between Wynnewood and Overbrook .	20
Note: When handling such trains, conductor must know that the engineer has been so advised.	

37-S4. (Cont'd)

EQUIPMENT	MPH
Snow Plows in service	20
Snow Flangers in service	20
Passing station platforms, trains on adjacent tracks and over all grade crossings	5
Note: When plowing, snow plow must be pushed with front end of engine coupled to plow. If engine is improperly turned and there are no facilities for turning, then a steel gondola should be placed between the plow and engine.	
Passenger train assisted by an engine on rear and air brake controlled by leading engine	30
Passenger trains consisting of more than 30 cars	60
Pushing Cars-Freight Trains	20
TPIX (Tropicana) Cars: Northward trains consisting of only loaded TPIX cars on the PW Line between MP 123 and MP 106	40
Trains handling pulpwood logs in bulkhead flats in multiple track territory	
On straight tracks	25
On curves	15
Trains with scale test cars or Jordan Spreader	25
Trains handling welded rail cars	40
Trains handling Speno Ballast Cleaning or Sweeper equipment	30
Trains handling Snow Plows and Flangers not in service	30
Trains handling steel slabs and ingot molds	40
Trains handling Subway Cars	40
Engines operating backwards by night over public crossings	15
An engine consist of more than one unit is considered as operating backward when the employee in the leading unit does not have full control of the engine.	
Trains with snow loader and snow melter units not in service	30
Note: Loader and melter units to be coupled and moved in train with loaded unit trailing.	
Trains with loaded Amtrak tie cars series AMT 15500-15594, in consist	45
This restriction applies to cars loaded with concrete or wood ties.	

37-S5. ENGINES & EQUIPMENT: MAXIMUM SPEEDS, UNLESS OTHERWISE RESTRICTED; DIMENSIONS

Engine numbers other than those listed below must not be run over any portion of the Northeast Corridor unless authorized by Form D.

NOTES:

- Numbers shown in “Equip. Dimen.” column denote engine or car heights, smallest being 1, largest being 8 (see pg. 297, 304). Each Line’s Special Instruction “40-x1” shows maximum height equipment that may be operated at each listed location.
- The symbol \leq denotes AC Electric Engines.
- The symbol \blacktriangledown denotes dual mode equipment. When operated in DC electrified territory, must be considered to be a DC electric engine, unless third rail contact shoes are removed or raised to position preventing contact with third rail.
- Locomotives equipped with **Locomotive Speed Limiters (LSL)** must not exceed the maximum authorized speed for freight trains.
- Locomotives equipped with **cab roof awnings** must have them folded flush against the cab when operating on, or adjacent to, Northeast Corridor main or running tracks.
- The symbol \blacktriangle denotes dual mode equipment able to operate as either diesel or AC electric engine. When operated in AC electrified territory, must be considered to be AC electric engine unless it is known that pantograph(s) are down and ground hooks applied to prevent contact with catenary.

Engine No.	Bldr. Model	Speed MPH			Equip. Dimen.	Notes at End of Table
		Lite	Mltip. Lite	With Train		
AMTRAK						
1-207	P-42BH	50	50	110	1	...
401-405, 407-409	F40PH	50	50	100	4	...
500-519	P32-BWH	50	50	100	4	...
520-527	GP38 H-3	50	50	65	4	...
530-539	MP-15	30	50	65	3	...
540-541	SW1500	30	45	60	3	...
569	SW1001	30	45	60	2	S
570-579	GP-15	50	50	65	2	...
597, 599	2GS12B	30	45	50	4	C
600-670 \leq	ACS-64	50	50	125	1	...
680-694 \leq	HHP-8	50	50	125	1	...
700-717 \blacktriangledown	P32AC-DM	50	50	110	1	...
720-724	GP38	30	50	65	3	...
737	SW1	30	45	50	4	C
790-799	SW1000	30	45	50	2	S
800-832, 835, 837, 839	P-40BH	50	50	110	1	...
900-953 \leq	AEM-7	50	50	125	1	...
B&M / GTI / ST / MEC						
12, 15	GP7	30	50	65	3	...
45, 51, 52, 54, 62, 71, 72, 77	GP9	30	50	65	3	...
203-216	GP35	30	50	65	4	...
252	GP38	30	50	65	4	...
300-355, 370-381	GP40	30	50	70	4	K
500-519	GP40-2	30	50	70	5	K

37-S5. (Cont'd)

Engine No.	Bldr. Model	Speed MPH			Equip. Dimen.	Notes at End of Table
		Lite	Mltip. Lite	With Train		
CDOT						
125-130	BL-20	50	50	75	2	...
833, 834, 836, 838, 840-843	P-40BH	50	50	110	1	...
6690-6691	F7M	50	50	80	3	...
6694-6699	GP40-2H	50	50	80	4	...
CP Rail / D&H						
5670,5677, 5678,5689, 5690,5697, 5698	SD40-2	40	50	60	5	B, K
7303-7312	GP38-2	30	50	65	4	...
JTCX						
5711, 5809	E-8A	50	50	90	4	G
8850	SLUG	40	40	65	3	...
9275, 9276, 9625	SW1500	40	40	65	5	C
LIRR						
101,102 104,105	SW1001	40	40	40	2	S
150-172	SW1500	40	40	65	3	...
400-422	DE30-C	40	40	80	2	E, S
500-522 ▼	DM30-C	40	40	80	1	E
MARC						
10-36	MP36PH	50	50	90	4	...
51-69	GP40-WH2	50	50	100	4	...
70-75	GP39H-2	50	50	90	4	...
7100	Power Car	30	50	80	4	...
4900-4903 ≤	AEM-7	50	50	125	1	...
4910-4915 ≤	HHP-8	50	50	125	1	...
MBTA						
010 & 011	MP36PH-3C	50	50	90	4	...
902, 904	GP9	50	50	60	4	T
1000-1017	F40PH	50	50	100	4	...
1025-1036	F40PHM	50	50	100	4	...
1050-1075	F40PHC	50	50	100	4	...
1115-1139	GP40-MC	50	50	100	4	...
MBTX: 2000-2039	HSP-46	30	30	90	4	K
3248 & 3249	GS21B	50	50	70	4	...
MNRR						
101-106	GP35	45	50	70	3	...
110-115, 125-130	BL-20	50	50	75	2	...
201-231	P32AC-DM	50	50	110	1	D
NJT						
502	SW1500	30	45	60	3	...
1001-1005	MP20B-3	30	50	70	2	...

37-S5. (Cont'd)

Engine No.	Bldr. Model	Speed MPH			Equip. Dimen.	Notes at End of Table
		Lite	Mltip. Lite	With Train		
NJT (Cont'd)						
4000-4032	PL42-AC	↓	↓	↓	4	...
Newark, NJ–Philadelphia		50	50	100		
All other routes		50	50	90		
4100-4112	GP40-PH2	30	50	70	4	K
4113-4129	F40PH-2B	30	50	100	4	...
4135-4144	GP40FH-2	50	50	100	4	...
4145-4150 4200-4219	GP40PH-2	30	50	100	4	...
Erie 834 & 835	E8A	50	50	80	4	...
4300-4303	GP40-2	30	50	100	4	...
4400-4431 ≤	ALP-44	50	50	100	1	...
4500-4534 Δ	ALP-45DP	50	50	90	1	V
4600-4628 ≤	ALP-46	50	50	100	1	...
4629-4664 ≤	ALP-46A	50	50	100	1	...
4800-4803	P-40BH	50	50	110	1	...
Engines Marked MNR Operated by NJT:						
4193 & 4194	F40PH-2	50	50	100	4	...
4900-4905	GP40FH-2C	30	50	100	4	...
4906	GP40PH-2M	30	50	80	4	...
4907-4914	F40PH-3C	50	50	100	4	...
NCDOT						
1755, 1797	F59PHI	50	50	100	5	...
1792	GP40H2	50	50	100	4	...
P & W						
100,102	SD70M-2	30	50	70	5	C, K
562, 582	B40-8W	30	60	70	4	C
GMTX: 2177, 2183, 2188 & 2192	GP38-2	30	50	65	3	C
2006-2009	GP38-2	30	50	65	3	...
2010-2011	GP38	30	50	65	3	...
2201	U-23-B	30	50	65	4	K
2215-2216	7-23B	30	50	65	4	K
3001-3003	GP-40	30	50	70	5	B, K
3004-3008	B30-7A	30	50	65	3	K
3901-3909	B39-8	30	50	70	3	K
4001-4004	B40-8	30	60	70	3	...
4005	B40-8W	30	60	70	4	...
CEFX: 3164, 3173	SD40-2	30	60	70	4	C, K
GMTX: 9000, 9014, 9059	SD60	30	60	70	4	K

37-S5. (Cont'd)

Engine No.	Bldr. Model	Speed MPH			Equip. Dimen.	Notes at End of Table
		Lite	Mltip. Lite	With Train		
SEPTA						
50	BL-1500	30	45	60	3	...
51, 52	SW1200	30	45	60	3	...
60-61	RL1000	30	50	65	3	...
70	2GS14B	30	45	60	3	F
2198	GP30	30	50	65	5	...
2301-2307 ≤	AEM-7	50	50	125	1	...
2308 ≤	ALP-44	50	50	100	1	...
VRE						
V20 & V23	GP-40H-2	50	50	100	4	...
V50-V69	MP36PH-3	50	50	90	4	...
WEST CHESTER RAILROAD						
1803	RS-18	30	50	65	3	...
CSO/NECR						
417, 437	GP40-3	30	50	65	4	...
1900, 1901	SD9	30	50	65	5	K
CSO 2340	SW-1500	30	45	60	4	...
CSOR: 3398, 3399, 3771	SD40-2	30	50	65	5	K
CSOR: 2021, 2038, NECR: 3840, 3843- 3848, 3850- 3857	GP-38	30	50	65	4	...
NECR 5032	SD40	30	50	65	5	C, K
NECR 6281	SD40	30	50	65	5	K
5215	SLUG	...	50	50	4	K
8511, 8530, 8552, 8554, 8565, 8579	B39-8	30	50	70	4	K
CSXT						
1-494	CW44AC	30	50	70	5	B, C, K
495-556	CW44AH	30	50	70	5	B, C, K
557-599	CW44AH	30	50	70	5	B, K
600-602	CW60AC	30	50	70	5	C, K
603-698	CW60AC	30	50	70	5	B, K
699	CW44-6	30	50	70	5	B, K
700-949	ES44AH	30	50	70	5	K
950-999	ES44AC	30	50	70	5	K
1006, 1008-1010, 1013, 1015-1018	MT6	30	45	50	6	C, K
1021-1024, 1040, 1042- 1048, 1050-1066, 1068	SWMT	30	45	50	4	C
1100-1112, 1114-1119	SW 1500	30	45	50	5	C
1122-1124, 1127	SW1001	30	45	60	4	C
1128	SW1001	30	45	60	4	...
1130-1139, 1150-1194	MP15AC	30	45	60	5	C
1140-1149	MP15	30	45	60	5	C

37-S5. (Cont'd)

Engine No.	Bldr. Model	Speed MPH			Equip. Dimen.	Notes at End of Table
		Lite	Mltip. Lite	With Train		
CSXT (Cont'd)						
1200-1241	MP15T	30	45	60	5	C, K
1300-1303, 1322	3GS21B	30	45	60	5	C
1304-1307	3GS21B	30	45	60	4	B
1314-1316, 1321	B36-3GS	30	50	70	5	...
1500-1524	GP15T	30	50	65	4	C
1534-1536, 1539, 1541, 1542, 1548, 1551-1553	GP15	30	50	65	4	C
1537, 1538, 1540, 1543-1547, 1549, 1550	GP15	30	50	65	4	...
2200-2374, 2377-2380	RDSLUG	30	50	65	5	C
2411-2419, 2422-2442	SD40-2	30	50	65	5	C, K
2443-2445	SD38-2S	30	50	65	5	C, K
2450-2454	SC38-2	30	50	65	5	C, K
2461-2463	SD38	30	50	65	5	B, C, K
2474-2499	SD50-2	30	50	70	5	C, K
2709, 2719, 2723	GP38-2	30	50	65	4	C
2717, 2718, 2720, 2724, 2740, 2793, 2804, 2807, 2813	GP38-2	30	50	65	4	...
2735, 2746, 2788, 2795, 2798, 2810, 2812-2814	GP38-2	30	50	65	5	...
2794, 2796, 2797, 2799-2803, 2806, 2808, 2809, 2811	GP38-2	30	50	65	5	B, C
3000-3374	ES44AH	30	50	70	5	K
4282, 4283, 4287, 4293-4295, 4297-4299	GP39	30	50	65	5	B, C, K
4300-4319	GP39-2	30	50	65	5	B, C, K
4405, 4406, 4412, 4415, 4418, 4422, 4423, 4429, 4431, 4441, 4450, 4451	GP40-2	30	50	70	4	K
4424-4428, 4430, 4432, 4434-4436, 4439, 4442, 4449, 4452	GP40-2	30	50	65	4	C, K
4500-4589	SD70AC	30	50	70	5	C, K
4612, 4617, 4621	SD40	30	50	65	5	C, K
4675-4699	SD70M	30	50	70	5	C, K
4701-4830	SD70AC	30	50	70	5	K
4831-4850	SD70AE	30	50	70	5	K
5000-5016	CW60AC	30	50	70	5	B, K
5101-5122	CW44AH	30	50	70	5	B, K
5200-5501	ES44DC	30	50	70	5	K
5507-5512, 5529, 5535, 5554, 5568, 5569, 5575, 5580, 5581	B30-7	30	50	70	4	C, K

37-S5. (Cont'd)

Engine No.	Bldr. Model	Speed MPH			Equip. Dimen.	Notes at End of Table
		Lite	Mltip. Lite	With Train		
CSXT (Cont'd)						
5834, 5839	B36-7	30	50	70	4	K
5875, 5877, 5878, 5880, 5884, 5885, 5887, 5891, 5894, 5897, 5902-5904, 5910, 5911, 5914	B36-7	30	50	70	4	C, K
5930-5959	B40-8	30	50	70	4	C, K
6137, 6139, 6346, 6352, 6355, 6356, 6362, 6392, 6398, 6399	GP38-2S	30	50	70	4	C
6150, 6151, 6155, 6157-6159, 6234, 6237, 6239, 6242, 6245	GP38-2S	30	50	70	4	B, K
6149	GP40-2	30	50	70	5	C, K
6152, 6153, 6156, 6160, 6209-6230, 6232, 6233, 6235, 6236, 6238, 6240, 6241, 6243, 6244, 6246-6249, 6280, 6295, 6318, 6341	GP40-2	30	50	70	4	B, K
6201, 6203-6207	GP40-2	30	50	70	4	...
6361, 6363, 6364, 6388, 6390, 6391, 6393-6397, 6400-6499	GP40-2	30	50	70	4	C, K
6595	GP40	30	50	65	4	C, K
6897-6899	SD60	30	50	70	5	C, K
6900-6909, 6911-6943, 6947, 6951-6973	GP40-2	30	50	70	4	C, K
7300-7396	CW40-8	30	50	70	5	B, K
7489-7498, 7500-7519, 7521, 7648	C40-8	30	50	70	4	C, K
7650-7917	CW40-8	30	50	70	5	C, K
7918-7929	CW40-8	30	50	70	5	K
8421, 8423, 8425-8427, 8429-8432, 8435-8437, 8439-8488	SD40-2	30	50	65	5	C, K
8611, 8620, 8624, 8628, 8629, 8635, 8641, 8662, 8665, 8667	SD50	30	50	70	5	C, K
8634, 8636-8640, 8642, 8643, 8660, 8661, 8666	SD50-2	30	50	70	5	C, K
8700-8721, 8787-8790	SD60	30	50	70	5	C, K
8722-8732, 8734-8736, 8738-8746, 8748-8755	SD60i	30	50	70	5	B, C, K
8733, 8737, 8747	SD60i	30	50	70	5	B, K
8756-8765, 8767-8786	SD60M	30	50	70	5	K

37-S5. (Cont'd)

Engine No.	Bldr. Model	Speed MPH			Equip. Dimen.	Notes at End of Table
		Lite	Mltip. Lite	With Train		
CSXT (Cont'd)						
8829-8831, 8834, 8840, 8841, 8843, 8845, 8848, 8852, 8854-8857, 8860, 8864-8869, 8874, 8880, 8882, 8885, 8886	SD40-2	30	50	70	5	B, K
8832, 8833, 8836, 8839, 8842, 8844, 8846, 8849, 8850, 8851	SD40-2	30	50	70	5	K
8835, 8838, 8853, 8863, 8870-8873, 8875-8879, 8881, 8883, 8884, 8887-8889	SD40-2	30	50	70	5	B, C, K
8900-8911	SD40-2	30	50	65	5	B, K
8984	SD45-2	30	40	40	5	C, K
9000-9052	CW44-9	30	50	70	5	C, K
9992, 9993	F40PH-2	50	50	100	4	...
9998, 9999	F40PH-2	50	50	100	5	...
NS/PRR						
700-736	RP-E4C	30	50	70	5	B
912-941	RP-E4D	30	50	70	3	C
1000-1174	SD70ACe	30	50	70	5	B, K
1700-1705	SD45-2	30	40	40	5	B, K
2100-2110	SW-1001	30	45	60	5	B
2200-2239	SW-1500	30	45	60	5	B
2501-2540 2557-2580	SD-70	30	50	70	5	B, K
2541-2556	SD-70	30	50	70	5	B, C, K
2581-2648	SD-70M	30	50	70	5	B, K
2649-2778	SD-70M-2	30	50	70	5	B, K
2800-2807	SD75M	30	50	70	5	B, C, K
3000-3028, 3034-3064	GP40-2	30	50	70	4	...
3029-3033	GP40-2	30	50	70	4	U
3071-3076	GP40-2	30	50	70	5	B
3077-3102	GP40-2	30	50	70	5	B, C
3170-3200	SD40	P
3329-3424, 3428-3429, 3431, 3434-3437, 3441-3442, 3444-3445	SD40-2	30	50	65	5	B, K
3522-3564	D8-32B	30	50	70	5	B, C, K
3800-3820	SD-38	30	50	65	5	B, K
4100-4159	GP38AC	P
4270, 4271	F9A	50	50	90	4	G
4275, 4276	F7B	50	50	90	4	G
5000-5016	GP38-2	P
5226-5393	GP38-2	30	50	65	4	...

37-S5. (Cont'd)

Engine No.	Bldr. Model	Speed MPH			Equip. Dimen.	Notes at End of Table
		Lite	Mltip. Lite	With Train		
NS/PRR (Cont'd)						
5400-5445	SD50	30	50	70	5	B, K
5601-5680	GP38-2	30	50	70	5	B
5801-5889	GP38-3	30	50	70	5	B
6300-6359	SD40-E	30	50	65	5	B, K
6550-6700	SD60	30	50	70	5	B, C, K
6702-6716	SD60	30	50	70	5	B, K
6717-6762	SD60I	30	50	70	5	B, K
6763-6806	SD60M	30	50	70	5	B, K
6807-6815	SD60M	30	50	70	5	B, C, K
911, 6900-6999, 7000-7017	SD60E	30	50	70	5	B, K
7200-7228	SD80MAC	30	50	70	5	B, K
7500-7719	ES40DC	30	50	70	5	B, K
8000-8165	ES44AC	30	50	70	5	B, K
8300-8313	D8-40C	30	50	70	5	B, K
8314-8467	D8-40CW	30	50	70	5	B, K
8689-8763	D8-40C	30	50	70	5	B, C, K
8764-8888	D9-40C	30	50	70	5	B, C, K
8889-9128	D9-40CW	30	50	70	5	B, C, K
9129-9978	D9-40CW	30	50	70	5	B, K
PAL						
2103	GP40-2	30	45	50	4	C
2108	GP35	30	45	50	4	C
NOTES:						
All CSX & NS Engines Prohibited as Follows:						
1. Between Hudson and Harold.						
2. Tracks 1 & 4 between Overbrook and Paoli.						
3. Pit Track through Harrisburg Station.						
4. Through Baltimore Penn Station, except via 1 or F tracks.						
Restrictions designated in applicable Line Special Instructions will apply at all other locations. Conductors or Engineers in charge of trains prohibited at any of the above locations must contact the Amtrak Dispatcher for instructions before entering the Northeast Corridor.						
<i>-See Notes on Next Page-</i>						

37-S5. (Cont'd)

"Notes at End of Table" for Equipment Operation:

- B** - May operate PW Line through B&P Tunnel between Charles and Bridge.
- C** - Prohibited from operating as a lead unit in CSS territory.
- D** - Before movement, third rail shoes must be removed.
- E** - **Exception:** When verbally authorized by Dispatcher at PSCC, may operate through the North River Tunnels *via tracks 3x and 4x only*.
- F** - Prohibited from operating on PH Line Track 4 past the high platform at Overbrook Station. May operate on all other locations as permitted by Equipment Dimension 3.
- G** - May operate at maximum passenger train speed when hauling passenger equipment exclusively. LSL freight train speed restriction does not apply to these engines.
- K** - Locomotive exceeds 290,000 pounds gross weight.
- P** - Engines prohibited on all Northeast Corridor Territory.
- S** - May operate between Bergen & Harold, and A & Empire only when verbally authorized by Dispatcher at PSCC.
- T** - May operate on DB Line. On NHB Line, must not operate any further west than distance necessary for movement to clear Atwells Int. On MM Line, may operate between Cabot & Tower 1.
- U** - May operate on Tracks 6 or 7 thru Baltimore Penn Station.
- V** - Dual mode equipment able to be operate as either diesel or AC electric engine. If operating in diesel mode, crew must notify the Dispatcher when entering the Amtrak Northeast Corridor.

Equipment Dimension Codes (engines & cars):

- 1** - Unrestricted operation on NEC not exceeding 14' 8" in height
- 2** - May operate Between Bergen & Harold, and A & Empire only when verbally authorized by Dispatcher at PSCC.
- 3** - Plate B not exceeding 15' 1" in height
- 4** - Plate C not exceeding 15' 6" in height
- 5** - Plate E not exceeding 16' 2" in height
- 6** - Plate F, and TOFC/COFC not exceeding 17' 2" in height
- 7** - Auto racks not exceeding 19' 0" in height
- 8** - Plate H (double stack) not exceeding 20' 2" in height

37-S5. (Cont'd)

CARS

AMTRAK	Spd	Equip Dim
Amfleet Inspection Cars 10001, 10002, and 10005	125	1
Office Car 10020-10022	110	1
Amfleet car series 20000-22999, 25000-26999, 28000-28999, 42000-44499, 48000-48999	125	1
Michigan car series 44550-44999	125	1
Amfleet Capstone car series 81000-81499, 82000-82499, 83000-83499, 85000-85499; and Push-Pull equipped series 81500-81999, 82500-82999, 83500-83999, 85500-85999	125	1
Capitoliner Control Cars series 9632-9641*, 9643-9647, 9649-9651; Conference Car 9800	125	1
* Note: See restrictions for car 9637 in SI's 40-H1 (pg 146), 40-E1 (pg 154), 40-T1 (pg 167), 40-N1 (pg 187), 40-P1 (pg 212) & 40-W1 (pg 226)		
Amfleet or Capitoliner cars with over-inflated air bellows (air springs):		
(a) Through crossovers and turnouts	15	1
(b) All other movements (see S.I. 34-S1 , pg 279)	30	
Amfleet or Capitoliner cars with defective bolster anchor radius rod (Also see AMT-3 instructions 9.2.3 & 9.4.3)	30	
◆Horizon passenger car series 51000-54599, 58000-58109	125	1
◆ Note: Horizon Food Service cars series 53000 & 58000 are prohibited from operating in territory equipped for DC electrical (3rd rail) operation (see SI's 47-N1 & 47-T1). Exception: Cars 53501, 53505, 53509, 53510 & 53511 may operate in territory equipped for DC electrical operation.		
Viewliner Inspection Car 10004 (see S.I. 41-S9, pg 307)	110	1
Viewliner cars 8400, 62000-62090 (see S.I. 41-S9, pg 307)	110	1
Heritage car series 2500-2524, 7005, 8501-8559	110	1
Dome lounge 10031	110	5
Superliner I & II car series 31000-39046	100	5
High Level car series 39940-39975	90	5
Non-Powered Control Units (NPCU) 406, Series 90200-90415	100	4
Baggage cars 1000-1272, 1701-1763, 1800-1802, 1850-1857, 10093-10095	110	1
Material Handling Cars Series MHC 1500 to 1569	110	1
LDSL Cars: Baggage Cars 61000-61084	125	1
LDSL Cars: Sleeping Cars 62500-62534; Diners 68000-68039; Bag-Dorm Cars 69000-69039	90	1

37-S5. (Cont'd) – Cars

SEMI-PERMANENTLY COUPLED TRAINSETS		Spd	Equip Dim
Turboliner Cars RTL Nos. 2131-2162, 2270-2389		110	1
Note: This equipment is dual mode. When operated in DC electrified territory, it must be considered to be a DC electric engine unless third rail contact shoes are removed or raised to position preventing contact with third rail. Turboliner equipment must not be left unattended unless wheels are chocked.			
High Speed Trainset (HST) Cars 2000-2039 (power cars), 3200-3219, 3300-3319, 3400-3419, 3500-3559, and Instrumented Car 10003		150	1
HST cars with deflated air springs		90	
HST cars with over inflated air springs:			
Non-diverting routes		30	
Diverting routes		15	
HST Power Cars (2000-2039) operating with shroud raised on:			1
Leading Power Car		50	
Trailing Power Car		125	
HST towed with shroud raised		125	
HST operating without either a 3200 or 3400 series car (or the instrumented car 10003) adjacent to each powercar		125	
HST Power Cars 2000-2039, Lite		50	
HST Power Cars 2000-2039, Multiple Lite		50	
AMTRAK FREIGHT AND MW EQUIPMENT		Spd	Equip Dim
Ballast Hopper	11300 - 11392	50	2
Ballast Hopper	11500 - 11731	50	2
Ballast Hopper, Air Dump	11795 - 11899	50	2
Ballast Hopper, Electric Dump	11901 - 11920	50	2
Wire Train Gondola (Reel Car)	13031 - 13039	50	2
Gondola 100 Ton	13200 - 13400	50	2
Air Side Dump Car	13901 - 13967	50	2
Cabin Car	14030 - 14035	50	2
MFS-40 Conveyor Hopper	A14602 - A14616, A14619-A14638, A14642, A14643, A14650-A14654	50	2
52' 6" Flat Car	15002 - 15029	50	2
52' 6" - 6 axle Flat Car	15030	50	2
40' Flat car equipped with fan	15051, 15054	50	2
40' Flat Car	15056 - 15058	50	2
Wire Train Tower Car	15188 - 15197	50	2
53' 6" Flat Car	15201 - 15225	50	2
CWR Plant Flat	15234 - 15240	50	2
Flat Car	15242 - 15248, 15901-15906	50	2
Casting Conveyor Flat Car	15907	50	2
Van Module Flat Car	15446	35	2
Concrete Tie Car	15500 - 15594	50	2

37-S5. (Cont'd) — CARS

AMTRAK FREIGHT AND MW EQUIPMENT (Cont'd)		Spd	Equip Dim
89' Flat Car	15610, 15612 - 15651	50	2
Flat Car for SES PK2 Crane A18201	15611	50	2
53' 6" - 6 axle Flat Car	15658 - 15799	50	2
53' 6" Flat Car	15800 - 15824	50	2
53' 6" - 6 axle Flat Car	15900	50	2
Wire Train Rider Car (pass)	16309 - 16312	50	2
Baggage Car	16320	50	2
Office Car	16719	50	2
50' MHC	16800 - 16808	50	2
Baggage Car	17011 - 17032	50	2
Box Car	17033 - 17037	50	2
RPO/Baggage Car	17041 - 17107	50	2
Switch Exchange System Car	A18001 - A18004		
Empty		50	2
Loaded (See SI 41-S8)	
A18101 with PK1 crane A18301		50	2
A18102 with PK1 crane A18302		50	4
DRGW 89' Escalator Flat Car	21738	50	2
KRL 70' Flat Cars	701200-701227	50	2
Herzog Air Dump Ballast Hoppers Series		50	2
HZGX 3979, 6301-6386, 6388-6407, 6609, 6613, 6639, 6650, 6656, 6660, 6685, 6686, 7417, 7764, 7775, 8682-8697, 8700-8774, 9156-9277, 9477, 9482, 9537, 9601-9695, 9722-9797, 9840-9893, 9924-9979			
PRIVATE CARS (see SI 34-S4, pg. 279)		Spd	Equip Dim
Type A		pnr	1
Type B		pnr	4
Type C		pnr	5
Type D		pnr	5
Type ND: Prohibited on Northeast Corridor	
C.D.O.T.		Spd	Equip Dim
Passenger Cars Series 1600-1606		90	3
Passenger Car Series 1614-1616, 1640-1646, 1648 & 1650 & Control Car Series 1687, 1691-1697, 1699		100	3
With over or under inflated air bellows (bags)		40	...
Passenger Car Series 1621-1631, 1633 (odd numbers only)		90	3
Passenger Cars 1730-1774 (even numbers only)		80	1
Control Cars 1001, 1671, 1673, 1675, 1680-1682		90	3
Control Cars 1701, 1703, 1705, 1707, 1709, 1711, 1713, 1715, 1717 & 1719		80	3

37-S5. (Cont'd) — CARS

CSX	Spd	Equip Dim
Office Cars Nos. 300, 307, 308, 310, 315, 318, 362 & 363	110	1
Office Cars Nos. 317, 319 & 350	90	4
Note: Office Car 361 is <i>prohibited on the NEC</i>
LIRR	Spd	Equip Dim
** LIRR C-3 Bi-Level (Trailer with and without toilet), Car Nos. 4001-4134, Bi-Level (Control) Car Nos. 5001-5023	80	1
LIRR M-3 Multiple Unit Cars: 9771-9946	80	
LIRR M-7 Multiple Unit Cars: 7001-7801	80	
** Exception: when verbally authorized by Dispatcher at PSCC, may operate through the North River Tunnels via Tracks 3x and 4x only.		
Maryland D.O.T.	Spd	Equip Dim
MARC II Series 7700-7735, 7791-7799 coaches, and 7745-7762 control cars (Push-Pull Service)	110	1
Push or Pull with over or under inflated air bellows (air bags):		
Through crossovers and turnouts	30	
All other movements	60	
MARC III Series 7800-7834, 7870-7876, 7890-7896 & Control Cars 7845-7858:		4
Washington to Philadelphia	125	
All Other Routes	90	
Push or Pull with over inflated air springs (there is no restriction when air springs are under inflated):		
Through crossovers and turnouts	15	
All other movements	30	
MARC Gallery Cars Series 7900-7911	80	5
MARC IV Series 8000-8033 coaches, 8090-8094 w/toilet	90	1
★ MARC IV Series 8045-8059 control cars	90	1
★ MARC IV control cars must not be operated as lead units in Cab Signal/ACES territory unless equipped with proper ATC components/event recorder.		
MBTA	Spd	Equip Dim
Pullman Standard Cars (Nos. 200-258)	80	3
Bombardier Cars 350-389, 600-653 & 1600-1652	80	3
MBB Cars (Nos. 500-532 & 1500-1533)	80	3
Kawasaki Double Decker Coaches (Series 700, Series 900-932 & Series 1700)	80	4
ROTEM Coaches: 800-846	80	4
ROTEM Cab Cars: 1800-1827	80	4
NOTE: All MBTA cars with an over or under inflated air spring on one end of the car must not exceed 50 MPH on non-diverting routes, and 25 MPH on diverting routes. When two or more cars in consist have this condition, the train must not exceed 25 MPH on non-diverting routes, and 15 MPH on diverting routes.		

37-S5. (Cont'd) — CARS

NJT	Spd	Equip Dim
Comet I Car Nos. 5707-5726, 5729-5735, 5737-5740, 5743-5746, 5748-5751	100	1
Comet IB Nos. 5220-5234	100	1
Comet II Car Nos. 5300-5459	100	1
Control Cars: Comet I Nos. 5100-5120, 5122-5131, 5133-5134, Comet II Nos. 5135-5154, Comet IB Nos. 5155-5169:		1
Pull Mode	100	
Push Mode	90	
Comet III Control Car Nos. 5000-5008	100	1
Comet III Car Nos. 5200-5205, 5500-5534	100	1
Comet IV Control Car Nos. 5011-5031	100	1
Comet IV Car Nos. 5235-5269, & 5535-5582	100	

Comet V Car Nos. 6200-6213 (toilet), 6500-6601 & Comet Car Nos. 6000-6083:		1
Newark, NJ to Philadelphia	100	
All Other Routes	90	
Multi-Level Control Car Nos. 7000-7061 & Multi-Level Car Nos. 7200-7298, 7500-7767 (trailer)	100	1
Hopper Car Series 9124-9154	25	3
★NJT Wire Train Cars 9950 to 9952	60	3
★NJT Tool Car 9998	60	3
★Operation is <i>prohibited</i> east of Portal.		

Cars Marked MNR Operated by NJT:	Spd	Equip Dim
Comet V Control Cars Nos. 6700-6714	90	1
Comet V Car Nos. 6750-6754 (trailer w/toilet)	90	1
Comet V Car Nos. 6755-6799 (trailer, no toilet)	90	1
NJT Passenger Cars with over or under inflated air springs:		
(a) Through crossovers or turnouts	30	
(b) All other movements	60	

NJT - MULTIPLE UNIT CARS	Spd	Equip Dim
NJT Arrow III Nos. 1304-1533	80	1
When MU air springs are deflated or over inflated:		
(a) Through crossovers or turnouts	30	
(b) All other movements	60	

If overriding buffer plates occur on MU cars, Dispatcher must be notified immediately. Speed of train must not exceed 15 MPH, and when moving through crossovers and turnouts 5 MPH. Trainmen and passengers must not occupy or pass through vestibule area while train is in motion.

North Carolina DOT	Spd	Equip Dim
Passenger Car 400000	90	1
Passenger Cars Series 400001-400011, 400013, 400014, lounges 400201-400203, 400205	110	1

37-S5. (Cont'd) — CARS

SEPTA	Spd	Equip Dim
Control Cars Series 2401-2410, 2460, 2461, & Passenger Cars Series 2501-2525, *2550-2559; 2590-2595		1
Pull Mode	100	
Push Mode	90	
Push or Pull with Air Springs Over or Under Inflated:		
(a) Through crossovers and turnouts	30	
(b) All other movements	60	
* End gates must be kept retracted, unless coupled to similarly equipped car.		
Cars 601, 602, 605, 606, 610	75	1
Gel Train Control Cars 615, 622	65	3
Cabin Cars 2002 & 2010**	45	3
** These cars are prohibited east of Bergen, and on No. 4 River Line trk. at Girard.		
SEPTA - MULTIPLE UNIT CARS	Spd	Equip Dim
SEPTA Silverliner II (Budd) Nos. 201-219, 251-269, 9001-9017	85	1
SEPTA Silverliner III (St. Louis) Nos. 220-239	85	
SEPTA Silverliner IV (GE) Nos. 101-188, 270-499	95	
SEPTA Silverliner V Nos. 701-738, 801-882		
Newark, NJ to Perryville, Philadelphia to Harrisburg	100	
All Other Routes	90	
When MU air springs are deflated or over inflated:		
(a) Silverliner IV & V through crossovers or turnouts	30	
(b) Silverliner IV & V, all other movements	60	
(c) Silverliners II & III through crossovers or turnouts	15	
(d) Silverliners II & III, all other movements	30	
If overriding buffer plates occur on MU cars, Dispatcher must be notified immediately. Speed of train must not exceed 15 MPH, and when moving through crossovers and turnouts 5 MPH. Trainmen and passengers must not occupy or pass through vestibule area while train is in motion.		
◆US D.O.T.	Spd	Equip Dim
DOTX 216	125	1
DOTX 217 (See SI 41-S13, page 307, 308)	90	4
DOTX 218	70	4
▶DOTX 219	90	4
▶DOTX 220	90	1
DOTX 221, 223	110	1
◆All US D.O.T. test cars must be towed by a locomotive, as they are not cab signal equipped (See SI 550-S1, pg 336).		
▶DOTX 219 and DOTX 220 must be operated in accordance with Train Type "C" speeds.		
VRE	Spd	Equip Dim
Passenger Car Series V405, V408, V412, V413, V415	80	5
Passenger Car Series V421-V430, V433, V437	80	5
Passenger Car Series V710-V730	80	5
Passenger Car Series V800-V827, V850-V879	80	5

37-S5. (Cont'd) — CARS

NOTES:

Equipment Dimension Codes (engines & cars):

- 1 - Unrestricted operation on NEC not exceeding 14' 8" in height
- 2 - May operate Between Bergen & Harold, and A & Empire only when verbally authorized by Dispatcher at PSCC.
- 3 - Plate B not exceeding 15' 1" in height
- 4 - Plate C not exceeding 15' 6" in height
- 5 - Plate E not exceeding 16' 2" in height
- 6 - Plate F, and TOFC/COFC not exceeding 17' 2" in height
- 7 - Auto racks not exceeding 19' 0" in height
- 8 - Plate H (double stack) not exceeding 20' 2" in height

37-S6. AMTRAK FREIGHT EQUIPMENT

Unless otherwise restricted, Amtrak freight equipment is authorized to operate at freight train speeds.

37-S7. EQUIPMENT FITTED WITH INSTRUMENTED WHEEL SET (IWS)

To facilitate periodic train-track dynamics testing, one truck of certain cars will be refitted with an Instrumented Wheel Set (IWS). Since, by design, the brake system on an IWS equipped truck is either removed or cut out, no brake test is required on the IWS truck. IWS equipped cars will be considered as having 100% operative brakes, as long as the brakes on the non-IWS end of the car are operative. *When an IWS equipped car is operated in a train consisting of less than 3 cars (including the IWS car), train speed must not exceed 50 MPH.*

37-S8. AMTRAK TRAINS WITH MAIL, BAGGAGE AND EXPRESS (MB&E) CARS

This instruction applies to Amtrak trains with mail, baggage and express (MB&E) cars operating between Washington and Boston, or New Haven and Springfield. ***MB&E trains operating between Philadelphia and Harrisburg are governed by SI 37-G6, page 241.***

An "MB&E" car is a 1500 series MHC car; 1000, 1100, 1200, 1700 or 1800 series baggage car; or 70000, 71000 or 74000 series express mail car (see S.I. 41-S14, pg.307, 308). A "passenger carrying car" is a car designed to carry passengers and/or provide on-board services (e.g., coach, sleeper, food service car), not including private cars.

- A. Trains with 14 cars or less may operate at Train Type C speeds if they have no more than 2 MB&E cars for each passenger carrying car.
- B. Trains with 14 cars or less must operate at ***Train Type D*** speeds on the PW, NYP, NYT & NHB lines (see SI 37-P1, 37-N1, 37-T1 & 37-B1), and passenger train speeds not exceeding 80 MPH on other lines, if they have:
 1. More than 2 MB&E cars for each passenger carrying car in consist, or
 2. No passenger carrying cars in consist.**Exception:** Trains of 14 cars or less that are handled by 1 or more AEM-7 or HHP-8 engines and have at least 1 passenger carrying car may operate at Train Type C speeds not exceeding 110 MPH, when the brakes on all cars are operative.
- C. Trains with 15 to 24 cars may operate at Train Type C speeds if they have no more than 2 MB&E cars for each passenger carrying car, *and the brakes on all cars are operative.*
- D. Trains with 15 to 24 cars must operate at ***freight train*** speeds if they have:
 1. More than 2 MB&E cars for each passenger carrying car in consist, or
 2. No passenger carrying cars in consist, or

37-S8. (Cont'd)

3. Inoperative brakes on any car.

Exception: Trains with 15 to 24 cars that have more than 2 MB&E cars for each passenger carrying car, or inoperative brakes on any car, may operate at *Train Type D* speeds on the PW, NYP and NHB lines, and passenger train speeds up to 80 MPH on other lines, if they have at least 4 Amfleet, Horizon, Viewliner, or Heritage Sleeper cars, **and** no more than 15 MHC or baggage cars.

E. Passenger trains with more than 24 cars are prohibited on all NEC lines except the PH line.

37-S9. SUCX FLAT CARS

Unless otherwise restricted, SUCX Flat Cars 54019, 54031, 54048, 54062, 54063, and 54073 are authorized to operate at freight train speeds.

OTHER LOAD AND EQUIPMENT RESTRICTIONS

41-S1. EAST, NORTH RIVER AND EMPIRE TUNNELS AND PENN STATION—NEW YORK

The following applies to the movement and storage of passenger and freight equipment through the East and North River Tunnels and Penn Station:

1. All hatch covers on cars must be closed and secured before entering tunnels.

2. Cars excluded from movement:

Cars containing shipments of hazardous materials requiring placards under the provisions of the current issue of CR/NS HM1, Hazardous Materials Regulations.

3. Operating limitations which must be observed:

(a) Passenger trains must not exceed 30 cars.

(b) Freight trains must not exceed 50 cars.

(c) Coal or charcoal ranges or heaters in kitchen or cabin cars of all steel construction must have fire banked prior to entering tunnels.

(d) Passenger and freight train cars containing butane, propane or other compressed flammable gas for cooking, lighting, heating, refrigeration or other purposes are restricted, unless such gas has been drained from the containers on cars so equipped or portable containers with other types of gasses have been removed.

EXCEPTION: Work trains may carry canisters of compressed oxygen and acetylene for welding and other maintenance activities within the confines of all HUD, NYT & NYP Line tunnels. Quantities must be limited to one day's expected use. Canisters of oxygen and acetylene, either empty or full, may not be stored in the tunnels.

4. GP type hoppers must not be operated on tracks equipped for third rail operation.

5. Diesel and Turbine engines in passenger service not capable of drawing propulsion power from 3rd rail must be hauled by electric engines between east portal of the East River Tunnels, west portal of the North River Tunnels and north portal of the Empire Tunnel. (Diesel and Turbine engines may be idling while being hauled). They may operate independent of third rail power only when authorized by the Dispatcher at PSCC. **EXCEPTION:** This instruction does not apply to diesel powered Sperry Cars, or other track maintenance equipment equipped with proper exhaust attachments.

41-S2. CARS EXCEEDING 263,000 POUNDS

Cars with gross weight exceeding 263,000 lbs. cannot be moved without permission of the General Manager.

41-S3. SINGLE-AXLE TRUCKS

Cars with single axle trucks must not be used as the rear car of any train operated in electrified territory. **EXCEPTION:** When necessary, Amtrak freight cars A18401 & A18402 may be used as the rear car of a work train moving to or from work locations. When this car is on the rear of a train, the Conductor must notify the Dispatcher. Rule 506, "Trains That Might Not Shunt," must be applied while the train is in ABS territory; and Rule 605, "Movements That Might Not Shunt," must be applied while the train is in interlocking limits.

41-S4. AMTRAK FREIGHT OR MW CARS

AMTRAK freight or MW cars must be examined by the Conductor to determine the restrictions. (Making note if the provisions of Rule 119 apply to their train.) The Conductor must notify the Dispatcher and Engineer of any restrictions affecting the movement of their train.

Trains containing this equipment are restricted as follows (Also see SI 41-S8, page 307):

Penn. Station, NY

Must run No. 11 or 12 tracks Penn. Station, N.Y.

*Cars 15003 & 15051-15062 may operate on Penn. Station, NY Tracks 1-16 & 18-21, but are prohibited on Track 17.

41-S5. AIR DUMP HOPPERS & GONDOLAS

Movement of trains with Amtrak Air Dump Ballast Hoppers or Air Side Dump Gondolas Series AMT 13900-13967 in the consist must not be made with main reservoir hose coupled between engine and cars, except when coupled for the purpose of immediate dumping by direction of MW Foreman.

41-S6. OPERATION OF DOUBLE STACK CARS

Operation of double stack cars is prohibited on the Northeast Corridor, except under the following conditions:

1. No restriction applies to empty cars (i.e., flat car with no containers).
2. Single level loaded cars with axle loading not to exceed 65,000 lbs. may operate on any track where freight trains are permitted.
3. MERX type container cars loaded with two-tier trash containers, with height not to exceed 17' 2" and axle loading not to exceed 65,000 lbs., may operate between Attleboro and Mansfield.
4. Multi-unit double stack trash container cars not exceeding a height of 17' 0" above the top of the rail and axle loading not to exceed 65,000 lbs., may operate on the MRS Line between New Haven and West Springfield, and on the HUD Line between CP 156 and Poughkeepsie.

41-S7. AMTRAK BALLAST CARS

Amtrak 14600 series MFS-40 ballast cars mandate that the "A" end of the car must only be coupled to the "B" end of another MFS type ballast car or Casting Conveyor flat car AMTK 15907. When the adjoining car is not an MFS-40 type ballast car, BMS or BMS-100, or Casting Conveyor flat car AMTK 15907, a flat car must be used as an idler car under the "A" end of the car. Coupling any other type of equipment to the "A" end of the car is prohibited.

41-S8. SWITCH EXCHANGE SYSTEM CARS

The following restrictions apply to the movement of Switch Exchange System (SES) cars A18001- A18004, A18101-A18102, Amtrak flat cars 15610-15619 and 15655-15799, and any other authorized flat cars when the cars are loaded with panels:

1. They may be moved with a clearance form provided under Rule 119(a).
2. They may be moved with the authority of, and when accompanied by, a qualified supervisor or MW Foreman. This supersedes the "required form" provision contained in Rule 119(a).
3. They must not exceed 30 MPH. (Also see SI 41-S4, page 306)

41-S9. VIEWLINER CARS: REQUIREMENT TO HAVE TRAP STEPS IN "UP" POSITION

Due to potential clearance problems, trap steps on Viewliner Cars 62000-62049 and Viewliner Inspection Car 10004 must be in the up position whenever these cars are moved outside of yards. (also see S.I. 37-S5, pg. 298)

41-S10. TLM, UNDERCUTTERS, POWER CARS

Amtrak TLM No. 25001, Undercutters Nos. N14901, N14904 & N14907, and Power Cars Nos. N14801 & N14802 must not exceed 25 MPH.

Due to potential clearance problems on the WT, PW, NYP, PH, 36SC, NYS, HUD, NYT & NYP Lines, this equipment must not be operated on main tracks or running tracks in these territories until the Conductor and Engineer have received written notification of any routing restrictions.

41-S11. RAIL PICK UP/UNLOADING UNIT

The Rail Pick Up/Unloading Unit is a 4 car unit numbered 15600-15603, and is used for loading old welded rail onto rail trains. While rail is threaded through the pickup unit, it must not be moved unless accompanied by a qualified MW employee, speed does not exceed 20 MPH, and distance does not exceed 20 miles.

41-S12. AMTRAK MW CRANES

Amtrak Kirow Crane A59601 is a self-propelled MW crane with 8 axles on span bolster trucks. It is authorized to operate in work trains at 30 MPH, or alone as a track car at 30 MPH. When crane A59601 is operating in a work train, it must be accompanied by an 89' flat car, either the AMTK 15615 or 15616. It has no clearance or weight restrictions on Amtrak lines.

American Crane A59019 is a self-propelled MW crane, and is authorized to operate at 30 MPH. American Crane A59019 is assigned equipment dimension 4, and may operate only on track segments where each Line's Special Instruction "40-x1" (for example, 40-B1, pg 116) lists equipment dimension 4 or greater.

41-S13. U.S. DOT TEST CAR DOTX 217

At certain passenger stations, operation of U.S. DOT Test Car DOTX 217 is prohibited on tracks that are adjacent to high level platforms, as indicated by an "X" below:

Line	Station	MP	Track Numbers				
			1	2	3	4	6
PW	Bowie State	119.4	X
	Baltimore Penn Station	95.7	X
	Wilmington	26.8	X

41-S13. (Cont'd)

Line	Station	MP	Track Numbers				
			1	2	3	4	6
NYP	New Brunswick	31.4	X
	Edison	28.9	X	...
	Metro Park	23.2	X
	Rahway	19.5	X	...
	Newark	8.8	...	X	...	X	...
NHB	New London	122.9	X
	Providence	185.1	...	X	X

41-S14. AMTRAK EXPRESS MAIL CARS

Amtrak Express Mail Cars Nos. 70000-70049, 71000-71299, & 74001-74111 may operate at speeds not exceeding 90 MPH, subject to the following restrictions:

1. Must not be moved unless plug doors are properly closed and secured.
2. **PROHIBITED** at the following locations:
NYS, HUD, NYT & NYP Lines: All tracks between Bergen & CP-216, including Penn Station and the Hudson Line.
Mid-Atlantic Div: (a) Trk 4 between N. Phila & Zoo.
(b) No. 4 River Line Duck Under at Zoo
(c) Through the New York-Pittsburgh Subway at Zoo.
(d) Through the 36th St. Tunnel at Zoo
(e) Baltimore Station Tracks 3, 4, 5, & 6.
(f) Washington Union Station Trks 12-14, & 17-20.
3. Must not exceed 50 MPH while operating on tracks next to high level station platforms at the locations indicated by an "X" in the table below:

Line	Station	MP	No. 1	No. 2	No. 3	No. 4	
NHB	Ruggles St.	226.5	X	...	X	...	
	Forest Hills	223.7	X	...	
	Hyde Park	220.3	...	X	X	...	
	Readville	219.2	...	X	X	...	
	Route 128	217.3	X	X	
	Canton Junction	213.9	X	X	
	Mansfield	204.1	X	X	
	Attleboro	196.9	X	X	
	South Attleboro	191.9	X	X	
Old Saybrook	105.1	X	X		
NYP	N. Phila	85	...	X	
	Trenton	56.7	X	X	
	Hamilton	53	X	X	
	Princeton Jct	47.1	X	X	
	New Brunswick	31.4	X	X	
	Edison	28.9	X	X	
	Metuchen	25.8	X	X	
	Metro Park	23.2	X	X	
	Rahway (MP 19.5)			Tracks A, B & 4			
	Linden (MP 17.3)			Tracks A & B			
		Elizabeth	14.1	X	X
		North Elizabeth	13	X	X
Newark International Airport Station (MP 11.2)			Tracks A, 1, 4 & 5				

41-S14. (Cont'd)

Line	Station	MP	No. 1	No. 2	No. 3	No. 4
PW	BWI	106.3	X	...	X	...
	Odenton	113.6	X	...	X	...
	Bowie State	119.4	X	...	X	...
	Seabrook	124.7	X	...	X	...
	New Carrollton	127	...	X	X	...
PH	Bryn Mawr	10.1	X
	Thorndale	35.3	X

41-S15. BRANDT TRUCK TRACK CAR TONNAGE LIMITS

The table below indicates tonnage limits for the operation of Brandt Trucks based on truck type.

EQUIPMENT	Amtrak Ballast or Other Track Material (OTM) Cars Not Exceeding 100 Tons	Herzog Ballast Cars Not Exceeding 131.5 Tons
500HP Brandt truck (AX27335)	9	7
On Track Grades of 1% or greater (see following table)	6	5
475HP Brandt Truck (AX26441, AX25481, AX24769)	7	5
On Track Grades of 1% or greater (see following table)	4	3

NOTE: For movements operating under Dispatcher's authority, the Foreman in charge must report the car count to the Dispatcher.

The following is a list of NEC locations where track grade is 1% or greater.

LINE	FROM	TO
NHB	Forrest	Back Bay
DB	Hill	Fairmount
	South Bay	Broad
MRS	None	
NYS	Harold	MP 9
HUD	A	MP 3
	CP 145	CP 146
NYT	NY Penn Station	Harold
NYP	NY Penn Station	Bergen
PW	Martin	River
	Biddle	Paul
	Charles	Pennsylvania Ave
	Frederick Road	Halethorpe
	B.W.I.	MP 108
	MP 118	Bowie State
WT	A	Division Post
PH	Zoo	Wynnewood
36SC	Penn	Zoo

CLOSE CLEARANCES

43-S1. CLOSE CLEARANCE SIGNS

At locations where “Close Clearance Signs” are posted, train crew members and other employees are prohibited from riding on side of moving equipment. The absence of these signs does not relieve employees from being familiar with locations of close clearance where signs are not displayed.

HAZARDOUS MATERIAL

45-S1. CARS PLACARDED EXPLOSIVES

Cars placarded Explosives must not be handled in trains hauling 50% or more of petroleum products in box or tank cars.

45-S2. HAZARDOUS MATERIALS REFERENCE

Employees involved in the transport of hazardous materials must refer to the current issue of the United States Hazardous Materials Instructions for Rail, HM-1 (Conrail, CSX, NS).

ELECTRICAL OPERATION

47-S1. ELECTRICAL OPERATION

All employees who work in Amtrak electrified territory must comply with the Electrical Operating Instructions (AMT-2), must maintain a copy of the AMT-2, and must have it with them while on duty.

47-S2. TRACKS EQUIPPED FOR AC ELECTRICAL OPERATION

Employees when qualifying on the physical characteristics of the railroad must familiarize themselves with the location of all electrified tracks.

Amtrak main tracks are equipped for AC electrical operation, **EXCEPT: Hudson Line**—Track 1 north of MP 1.1 and Track 2 north of MP 1; Post Rd Branch; **New Haven-Boston**—Controlled Siding between Pine & Orchard; Trk No. 4 between Meadow & Triebel; Trk No. 3 between Brook & Saybrook, Trk No. 4 between Groton & Palmers Cove; Trk No. 3 between Stony and end-of-track; Trk No. 4 between Davisville & Malcolm; Trk No. 3 between Packard & Atwells; Trk No. 7 between Atwells and Orms; Trk No. 4 between Hebronville & Holden; Trk No. 3 between Thatcher & Holden; **MRS Line** – All Tracks; **NYT Line**—F interlocking facing point interlocked crossover (771 switch) for eastward movement from No. 3 track (Line 3) to the LIC Eastward Passenger track.

Other Equipped Tracks: Dorchester Branch, No. 1 Track and No. 2 Track and associated switches and crossovers from Tower 1 to and including the diamond at South Bay, are equipped for AC electrical operation. Middleboro Main Line Track No. 14 to and including Cabot is equipped for AC electrical operation. Various non-main tracks on the above Lines are also equipped for AC electrical operation.

All electrified tracks east of dead sections catenary poles 204H to 206H (NYS Line) are controlled by the Metro North Power Supervisor at Madison Avenue, New York.

All electrified tracks between dead sections catenary poles 204H to 206H (NYS Line) and MP 76 (NYP Line) are controlled by the Power Director at Penn Station, New York.

All electrified tracks between MP 76 and Zoo (NYP Line) and between Zoo and MP 21 (PH Line) are controlled by the Power Director at CETC, in CNOC, Wilmington, DE.

All electrified tracks between MP 21 and Harrisburg (Philadelphia to Harrisburg) are controlled by the Power Director at Harrisburg Station, Harrisburg.

All electrified tracks between Zoo and Washington Terminal are controlled by the Power Director at CETC, in CNOC, Wilmington, DE.

All electrified tracks between New Haven & Boston are controlled by the Power Director at CETC, South Station, Boston, MA.

47-S3. PHASE BREAKS

Location	Tracks	Catenary Br or Signal Br	Distance of Break
NYP Line	2 & 3	W 3.44	200 feet East of & 200 feet West of Catenary Pole W 3.44
PW Line: Perry	1 & 2 3 & 4	Cat. Br 58.68	200 feet Northward & Southward
PH Line	1 & 2 3 & 4	Cat. Br 33.78 Cat. Br 33.71	360 feet Eastward 360 feet Westward

47-S4. POSITION LIGHT PHASE BREAK INDICATORS

In service on track	Governs track(s)	For direction	Location of Indicator	Distance from Phase Break
PW Line: Perry				
1	1	North & South	Northward trains: Sig. Br. 590 Southward trains: Coudon's Rd. OHB, MP 58.34	1425 feet
2	2			1425 feet
3	3			1425 feet
4	4			1425 feet
PH Line: Thorndale Substation				
1	1 & 2	East	Eastward trains: Cat. Br. 34.15	1925 feet
3	3 & 4	East		1925 feet
1 *	1 & 2	West	Westward trains: Cat. Br. 33.39	1900 feet
4	3 & 4	West		1900 feet
* Phase Break Indicator in service to the left of the track.				

47-S5. TRANSFER OF EMPLOYEES OR PASSENGERS BETWEEN EQUIPMENT ON ADJACENT TRACKS

Section 3.7 of AMT-2, Electrical Operating Instructions, is revised as follows:

3.702 Throttle power shall not be applied on either train until the transfer process is complete.

NOTE: Reference is made in Instruction 3.701 to “jumper cables” to be used when performing a train to train transfer. Instructions regarding the use of jumper cables (if they are available on your train) are contained in Chapter 1 of the “Service Standards for Train Service & On-Board Service Employees”, pages 1-54 to 1-56, in instruction (C)(4) titled “Passenger Transfer Between Two Trains With a Jumper Cable and Transfer Bridge”. *All High Speed Trainsets in revenue service have been outfitted with a transfer bridge and jumper cable. These items are stored in the cafe car cabinet across from the Railfone.*

47-S6. AMT-2 ELECTRICAL OPERATING INSTRUCTIONS: SECTION 2

The pages headings of AMT-2 Section 2, pages 2-1 through 2-26, referring to Section 3, are retitled “SECTION 2: GENERAL INSTRUCTIONS”.2: GENERAL INSTRUCTIONS”.

47-S7. AMT-2 ELECTRICAL OPERATING INSTRUCTIONS: INSTRUCTION 2.401: PANTOGRAPHS

The following table replaces the second and third paragraphs of AMT-2: 2.401, page 2-12, in their entirety.

Table 2-2. Pantograph Which Must Be Up During Normal Operation of Electric Equipment:

Company	Equipment	Pantograph Up During Normal Operation	Notes
Amtrak	ACS-64	Rear / Trailing	1
	High Speed Trainsets	Lead Powercar: "F" Trail Powercar: "R"	1, 3
	HHP-8	Rear / Trailing	1
	AEM-7	Rear / Trailing	1
Amtrak, SEPTA, MARC	Push-Pull	Either	2
NJT	Push-Pull	Rear / Trailing	1, 2
Note 1: "Front" and "Rear" means the position of the pantograph on each locomotive, power car or MU car in relation to the direction of movement, <u>not</u> the equipment ends stenciled "F" or "R".			
Note 2: "Push-Pull" means a passenger train with a Multiple Unit (MU) or control car on either end.			
Note 3: Pantograph knuckles are to face forward on both power cars.			

47-S8. AMT-2 ELECTRICAL OPERATING INSTRUCTIONS: INSTRUCTION 3.506: ELECTRIC POWER RESTRICTIONS DUE TO POWER SHORTAGES

The first paragraph of AMT-2: 3.506, page 3-8, is revised as follows:

When one or more of our power suppliers advises us that they are unable to provide sufficient capacity for our electric service, the Dispatcher (or Operator when authorized by the Dispatcher) will verbally notify trains that Instruction 3.506 is in effect.

The table in AMT-2: 3.506, page 3-8 is revised as follows:

Equipment	Controller Position/Power Effort Must Not Exceed:	Notes
ACS-64 Engines	50,000 foot pounds	...
HST Power Cars	50,000 foot pounds	...
HHP-8 Engines	50,000 foot pounds	...
AEM-7 (AC) Engines	7,500 ft. lbs. per traction motor	...
AEM-7 (DC) Engines	1,500 amps	...
ALP-44 Engines	1,500 amps (or Notch 6)	...
ALP-46 Engines	1,500 amps (or Notch 6)	1
Control Cars operating with ALP 44/46 Engines	Notch 6	...
MU Cars	P-2 Position	...
Note 1: Total line amperage can be viewed on ITU Propulsion Screen.		

47-S9. AMT-2 ELECTRICAL OPERATING INSTRUCTIONS: CATENARY POWER OUTAGES

AMT-2, Instruction 3.503 is revised for clarity.

3.503 No Pantograph Damage Found – Power Immediately Restored - If no pantograph damage is found and catenary power is immediately restored, the Dispatcher must direct trains operating on the affected track or an adjacent track within the limits of the power outage area to inspect for catenary damage on the affected track, following the inspection guidelines in instruction 3.505, “Inspecting for Catenary Damage”. If no catenary damage is revealed after the entire outage area has been inspected, train(s) within the affected catenary circuit may operate at Normal Speed.

47-S10. AMT-2 ELECTRICAL OPERATING INSTRUCTIONS: 3.106: ELECTRIC ENGINES

ACS-64 engines are added to the first paragraph of AMT-2: 3.106 and new section E. is added.

The operation of more than two (2) electric locomotives, except MU cars, in a train is prohibited. When there are more than two electric locomotives in the consist, the remaining units will not provide traction power. AEM-7-DC units will be live-in-tow, unless defective. ACS-64 units, AEM-7-AC units, HHP-8 units and High Speed Trainsets will be dead-in-tow (pantograph(s) down) with 480 V power to locomotive(s) or train.

Locomotives or trainsets in tow must be moved as follows:

E. ACS-64: Pantograph(s) must be down. 27-Point MU cables and 480 V cables must be connected between units. Brake pipe, main reservoir, and all MU hoses must be connected. The emergency magnet valve must be cut out. HEP Control switch (Auxiliary Rack) needs to be positioned in “HEP Line”.

72-S1. RADIO ALARM HOT BOX/Dragging Equipment Detectors

The following instructions will apply:

As a train approaches a detector, the detector will check it's own integrity. If the detector fails the integrity test, it will transmit a message stating the location and track number of the detector, the ambient temperature and the words “Integrity Failure”. If the dragger feature has malfunctioned, it will transmit the message “Stuck Dragger”.

Immediately upon detection of the first defect, the system will transmit the milepost location, the track number and the message “Defect detected.”

When this message is received, the train must be stopped when rear end is clear of the detector.

When entire train has passed the detector, a radio message will be transmitted stating the results of the inspection. After a one second delay, the message will be repeated.

If a defect is detected, the train must be stopped and inspected in accordance with the instructions received, and the Dispatcher notified.

Detector will identify suspected hot journals or dragging equipment by axle number counting from head end (including engines). If a defect is not found at the axle location specified, that entire car and the 2 cars immediately ahead and behind that car must be inspected. If the radio transmission reports 6 defects, which is the maximum number the detector can transmit, the entire train behind the 6th defect must be inspected.

If Radio Alarm Detector fails to transmit the results of the inspection, or if the detector transmits that it has had an integrity failure or a stuck dragger, the Dispatcher must be promptly notified.

The final transmission from the Radio Alarm Detector must be acknowledged.

Example: “Amtrak No. 171 Eng 205 at Midway on No. 1 track, no defects, out.”

All Radio Alarm Detectors will transmit on Road Radio channels as designated on Station pages.

72-S2. WHEEL INSPECTION

When a train has been stopped because of sticking brakes, sliding wheels, or actuation of hot wheel scanner an examination of the car wheels must be made. If wheel shows signs of being overheated, the air brakes of that car must be cut out. If any cracks are found in the wheel, car must be set out. Attention must be given to flat spots and be governed by Rule 71.

When a train has been stopped because of actuation of Hot Wheel Scanner and no defect is found on reported car, crew members must inspect the two cars ahead and the two cars behind the reported car for defects.

72-S3. HOT BOX DETECTORS AND RECORDERS

Hot Box Detectors and Recorders which measure and record the heat of passing journal boxes are in service at various locations.

At all installations, arrangements must be made to stop trains as soon as possible when the hot box detector so indicates by the recorder.

Train or engine crews, upon contacting Dispatcher or Operator, will be advised as to which side of car and which journal has the defective condition.

After the examination of a hot journal has been completed, the following information must be given to the Dispatcher:

1. Confirmation of the location of suspected car(s) in train.
2. The initial and number of car(s) and waybill information.
3. Condition of journal(s).
4. Location of hot journals to include the following:
Truck (lead or trailing), Wheel (lead or trailing), Side (north, east, south, west)
5. Type of bearing (friction or roller)
6. Type of packing if friction type bearing
7. Any other pertinent information.

If on observation no exception is taken to the reported defective car, crew members will be responsible for observing journal condition of the two cars ahead and two cars behind the reported car, opening journal box lids, if so equipped, for thorough observation.

Operator will advise train crew of the suspected car(s) counting from the head end.

72-S4. USE OF TEMPILSTIK

Conductors, Assistant Conductors and Engineers must obtain and carry with them while on duty a 200, 212 or 219 degree Tempilstik (Amtrak crews-212 or 219 degree Tempilstik).

72-S5. OVERHEATED BEARINGS-ENGINES

When engine develops an overheated axle bearing or motor axle suspension bearing enroute, engine will be isolated, if possible, or traction motor circuit cut out and operated with caution not exceeding a speed of 10 MPH to the next point where instructions can be received or where engine may be set off.

Any engine reported having an overheated axle bearing or motor suspension bearing or found overheated on inspection must not be dispatched.

72-S6. HOT BOX INDICATORS ALARMS AND HOT JOURNALS

On a car known to have a hot journal, the air brakes must be cut out and all air released from reservoirs as promptly as practicable.

Engines or cars equipped with smoke and/or odor hot box indicators will release a strong penetrating odor and/or a volume of dense white smoke when bearings become overheated. When either of these indications is observed, train must be stopped and a prompt report made to the Dispatcher.

The use of sand or dirt for extinguishing fires in journal boxes is prohibited. Water or snow should not be used for cooling hot journals except in an emergency and when used, journal should be cooled as slowly as conditions will permit.

When a journal equipped with a lubricating pad is found overheating enroute, train must be stopped and examination made. The lubricating pad must be adjusted or replaced with an oil saturated pad in good condition if this will overcome trouble. If cause of heating cannot be corrected in this manner or car cannot be moved to the next terminal through use of cooling compound, car should be set out.

Cooling compound shall be used for emergency treatment of overheated journals of cars enroute and should be used before journal becomes red.

Journals with broken brasses shall not be treated with cooling compound.

When applying cooling compound, it shall be placed along full length of rising side of journal, particular attention to be given to placing compound at back or inside end of journal. Cars having journals treated with cooling compound shall be tagged in a prominent place near journal, using prescribed form at time compound is applied.

When cars with hot journals are set out where inspectors do not take immediate charge, the crew must make a careful inspection of the underside of wooden flooring to determine that it has not been ignited by the blaze from the hot journal and must extinguish all fire before proceeding with the train and the journal should be left in such condition as to avoid damage to car by fire.

Conductor must make prompt report to Dispatcher of cars treated enroute or set out account overheated journal stating whether treated by cooling compound, by water or snow, also whether heating was detected by odor or smoke or hot box alarm.

72-S7. WAYSIDE HOT BOX DETECTORS – 2 CONSECUTIVE ACTUATIONS

NOTE: The procedures outlined in this instruction apply equally to cars *and* engines.

When the same car of a train actuates 2 consecutive wayside hot box detectors which require the train to be stopped and inspected, and no hot bearing or other defect which may have caused the hot box detectors to actuate (i.e., sticking brakes) is found on that car or the 2 cars ahead and behind it, the following actions must be taken:

1. The train must not exceed 30 MPH for the next 5 miles.
2. The train must be stopped at that point and all bearings of the car reported to have actuated the detector reexamined. The 2 cars ahead and behind the reported car need not be reexamined during the 5 mile inspection.
3. If no hot bearing is found during the 5 mile inspection:
 - a. The Dispatcher must be promptly notified.
 - b. The Train must not exceed 80 MPH, and
 - c. The car must be set out at the next major terminal: Washington, Philadelphia, Harrisburg, New York, New Haven, or Boston.

When a train actuates the last wayside hot box detector before a crew change location, the relieving crew must be advised of the car that actuated the detector so that they can follow the above procedure if the car actuates the next wayside hot box detector enroute.

Note: Refer to AMT-3, Air Brake and Train Handling Rules and Instructions, for instructions regarding On-board Hot Box Detectors.

72-S8. WHEEL IMPACT DETECTORS

The wheel impact detectors installed at the locations listed in line special instructions to measure the amount of vertical force produced by each wheel in thousand pound units called "KIPS". If a wheel impact reading of 140 KIPS or higher is detected, the train must be stopped and inspected as specified below, and the Dispatcher notified.

a) Defect Notification

When a train produces a wheel impact detector reading of 140 KIPS or higher, the Consolidated National Operations Center (CNOC) will receive notification and must provide the applicable CETC dispatching office with the information necessary to identify and stop the affected train. Suspected wheels must be identified by side of car, axle, and car count from the head end (or car number & wheel location, if car is equipped with an automatic equipment identification (AEI) data tag).

Radio Alarm Wheel Impact Load Detector: When a train produces a wheel impact detector reading of 140 KIPS or higher at a Wheel Impact Load Detector equipped with a supplemental radio alarm, in addition to notifying CNOC, the system will transmit a message approximately 30-60 seconds after the last car clears the detector, stating "Amtrak", the mile post location and track number of the detector, the car number (if the car is equipped with an AEI data tag), the suspected defect location by axle count from the head end including engines, and the message "wheel impact exceeding threshold, out." When this message is received, a crewmember must acknowledge the transmission, report the suspected defect to the dispatcher, and the train must be stopped. Note: This defect message will only be transmitted one time, and no message will be transmitted unless a defect is detected.

b) Required Inspection

Once a train crew has been notified that their train produced a wheel impact detector reading of 140 KIPS or higher, the train must be stopped and a crewmember must inspect the suspected wheel(s) for flat spots or other visible defects. If a defect is not found at the location specified, that entire car and the 2 cars immediately ahead and behind that car must be inspected. The results of the inspection must be reported to the Dispatcher.

- If a defect is found, the Dispatcher must contact the CNOC Mechanical Desk for instructions regarding how the car or engine is to be handled.
- If no defects are found the Dispatcher may permit the train to proceed at Normal Speed to its destination.

72-S9. WAYSIDE HBD ACTUATION ON EQUIPMENT WITH OBHBD SYSTEM

ACS-64 locomotives, Highspeed Trainsets, HHP-8 locomotives and Amfleet cars are equipped with an On-Board Hot Bearing Detection System (OBHBD). If a wayside Hot Box Detector actuation indicates a defect on more than two consecutive axles of this equipment, a crewmember must verify that the OBHBD is working on each car/locomotive indicated and determine whether any defects or system faults have been activated. If the inspection of the on-board system reveals no exception before the train has stopped, the Dispatcher must be notified and the train may continue at normal speed without additional inspection.

If the next wayside hot box detector indicates a defect on one of the same cars/locomotives indicated above, it will be considered the second consecutive actuation and the requirements of SI 72-S1, S3, S7, A3 and A4 will apply.

80-S1. MOVABLE POINT FROGS & SLIP SWITCHES

To enhance ride quality, many interlocking crossovers and turnouts are equipped with movable point frogs. Movable point frogs are power operated, and must be properly lined for straight and diverging movements. Trains or other on track equipment required to operate at Restricted Speed within interlocking limits (e.g., Rule 241 or out-of-service track) must be prepared to stop short of an improperly lined movable point frog. The photo in **Fig. A** shows a movable point frog that is properly lined for a straight movement on the track to the right. The photo in **Fig. B** shows a slip switch with a movable point frog that is properly lined for a straight movement on the track in the center. **Note:** Some slip switches do not have movable point frogs.

Interlockings equipped with movable point frogs or slip switches are indicated in the notes on each Station Page, however, this does not relieve employees from being prepared to stop within one half the range of vision short of a movable point frog or slip switch not properly lined at **any** interlocking when movement at Restricted Speed is required.

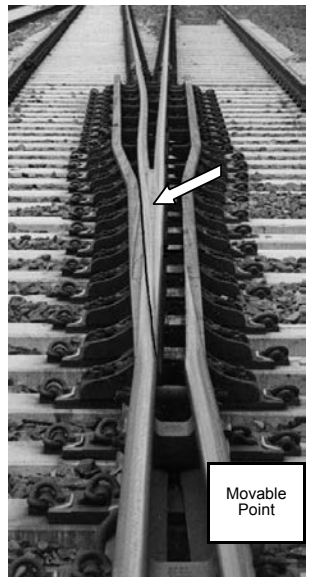

Fig. A



Fig. B

100-S1. COUPLING SPEED: ACS-64, HHP-8 ENGINES & HST POWER CARS

A stop must be made just prior to a coupling involving ACS-64 Engines, HHP-8 Engines, or HST Power Cars. Coupling speed must not exceed 2 MPH. Coupling at a speed greater than 2.5 MPH will result in the shear ring breaking and damaging the coupler. When this occurs the coupler must not be used until repaired.

101-S1. SWITCHING BAGGAGE CARS

When switching baggage cars containing metal mail containers, Trainmen are prohibited from riding inside car while movement is being made. No baggage cars containing metal mail containers will be moved until all doors of car are closed. Mail Foreman on platform will ensure these doors are closed.

109-S1. NJT COMET EQUIPMENT: CUTTING OUT CONTROL STAND & SECURING TRAIN

This instruction applies to Amtrak employees handling trains with NJT Comet cars in consist. Before cutting out the operating control stand, the Engineer must ensure that a minimum of two hand brakes are applied to secure the train. The Conductor must promptly notify the Engineer when the hand brakes have been applied.

116-S1. SHOVING OR BACKING MOVEMENTS

A. Location Of Engineer: The Engineer must operate from the leading end of the movement when equipped with an operating compartment, cab car or properly pointed locomotive.

Exceptions: Engineers may operate from other than the leading end of the movement:

1. As listed in Line Special Instructions.
2. When authorized by the Train Dispatcher.
3. When changing ends would occur in a tunnel.
4. When the movement does not exceed one train length on a main track, or one train length beyond an opposing interlocking signal.

B. Engineer Operating From Other Than the Leading End of Movement: When an Engineer operates a train from other than the leading end of the movement:

1. Crew members must take proper action to control the movement.
2. The maximum authorized speed is: Not exceeding 20 MPH.
3. The crew member directing the movement must be qualified on the physical characteristics of the territory.

And

4. The crew member directing the movement and the Engineer must work together to comply with the requirements of Restricted Speed, or movement on other than main track, when applicable.

C. Location of Crew Member Directing Movement: When cars or engines are being shoved, a crew member must be on the leading end of the movement at all times if the leading car or engine is equipped with an operator's compartment, vestibule, doorway, platform or a side ladder.

If not equipped, or when close clearances do not permit riding the side ladder, the crew member directing the move must precede the move and ensure that switches and derails between the movement and his/her location can be plainly seen and known to be in proper position.

When a crew member is specifically required by an operating rule to precede a shoving movement, another crew member must be stationed on the leading end of the movement, when the leading car or engine is equipped with an operator's compartment, vestibule, doorway, platform or a side ladder.

Exceptions:

- 1) After making a safety stop prior to coupling, in accord with AMT-3 Rule 3.1.1, the crew member on the leading end of the shoving movement may dismount in order to oversee the coupling.
- 2) When a model P32AC-DM locomotive (Series 700-717) is being shoved a crew member must either be on the leading end or precede the movement. When on the leading end, hand signals or radio headset(s) may be utilized.

Note: When a radio headset is used, it must be tested by the crew member in accordance with NORAC Rule 703 prior to commencement of the move to ensure that it functions as intended.

D. Crew Member Required Communications: When the crew member on the leading end of the movement is directing the movement by radio, he/she must inform the engineer of the position of switches (unless governed by signal indication) and derails,

116-S1. (Cont'd)

signal indications, and other conditions that may affect the movement prior to the start of the shoving or backup movement. This information must be included, when applicable, in subsequent instructions during the movement.

The crew member directing a shoving or backing movement by radio must include, in addition to the above, his or her title and whether they are on the point or preceding the move (due to close clearance, or when the leading car or engine is not equipped with an operator's compartment, vestibule, doorway, platform or side ladder). *The engineer must not start movement until this information is received.*

If hand signals are being used instead of radio, Engineer must not start movement if employee directing a shoving or backing movement is not on the point of movement, unless advised verbally by employee that movement will be preceded and the reason for doing so. This verbal communication can be either face-to-face or over the radio.

116-S2. OPERATING FROM OTHER THAN THE LEADING END WITH OCCUPIED PASSENGER EQUIPMENT

When operating from other than the leading end with occupied passenger equipment, a back-up hose or the emergency brake valve must be used by the crew on the leading end of the move. A test of the back-up hose must be made in accordance with AMT-3 Instruction 5.4.2.

Exception: Movement may be made without a back-up hose or crew member in position to operate the emergency brake valve when a full baggage car is on the leading end of the movement and/or conditions make it unsafe for the crew member to ride on the side of the leading car. In such a case, the crew member must walk ahead of the train to direct movement.

For the purpose of this instruction the following constitute occupied passenger equipment:

- Occupied passenger cars in revenue service, including private cars.
- Occupied in-service business cars, inspection cars, and Department of Transportation (DOT) cars.

119-S1. HANDLING OF HAZMAT, EXCESSIVE WEIGHT, OR EXCESSIVE DIMENSION CARS

Trains containing hazardous material, excessive weight or excessive dimension cars must not occupy an Amtrak main track or running track until the Conductor or Engineer has communicated with the Dispatcher, and ensured that the Dispatcher has received the required restricted car information.

131-S1. PROTECTING WORK LOCATIONS: CONDUCTOR/FLAGMEN RESPONSIBILITY

1. Any employee that accepts an assignment as a Conductor/Flag must have a valid Roadway Worker Protection card in their possession.

2. Conductor/Flags are required to hold a job briefing (On Track Safety) with all railroad and private contractor employees working at the specific job site that the Conductor/Flag is assigned to protect. Conductor/Flags must document every briefing with employees and contractors on NRPC Form 3044-C. After completion, this form must be retained for ten (10) days.

3. The Conductor/Flag will be responsible for securing authority for contractor employees to foul the tracks of the railroad. The contractors will not be allowed to foul or obstruct any track/catenary structure under foul time until a member of the contractor's group has signed off on the Authority to Foul Tracks Record form NRPC

131-S1. (Cont'd)

3045. The Conductor/Flag must not release foul time until the same member of the contractor's group has signed off in the release portion of this same form.

4. When a Conductor/Flag is assigned as the employee in charge of protection for employees and/or contractors who require foul time, the Conductor/Flag must:
 - A. Discuss the form of protection during the job briefing with all employees and contractors involved;
 - B. Determine who possesses the formal authority of protection for the section of track in question;
 - C. If anyone other than the Train Dispatcher or an NHB, DB or MRS Line "Point Conductor" (RWP employee in charge) is in charge of the track, the Conductor/Flag must read or obtain a copy of the Form D or Foul time authority [NRPC 3045] from the person in charge of the track.
 - D. When a "Point Conductor" receives or releases foul time directly with the Train Dispatcher, paragraph C above applies to the Conductor/Flagmen under the jurisdiction of the "Point Conductor", and such Conductor/Flagmen must receive and record foul time authority from the "Point Conductor" using NRPC Form 3045.
5. Conductor/Flags must ensure that a brake application has been made and where possible, have visual confirmation that the brakes have applied and released on each piece of equipment in the work unit. The Conductor/Flag must then have the operator perform a "rolling stop" to ensure proper brake operation on units where it is not possible to visually observe the application and release of the brakes.
6. Flagging assignments, although not considered covered service under the Federal Hours of Service law, will be governed as follows:
 - A. Conductor/Flags must not perform service in excess of twelve (12) hours on the job site unless authorized by a Trainmaster.
 - B. Conductor/Flags who work a flagging assignment in excess of four (4) hours on the job site, must have at least eight (8) hours rest before accepting another flagging assignment.

OUT-OF-SERVICE TRACKS

132-S1. MAINTENANCE WORK WITHOUT FORM D

Work or wire trains, single unit rail grinding track cars, the MPMV, and the MTW-100 catenary inspection car, may perform work without Form D Line 4, but only under the conditions listed below:

1. Permission is obtained from the Dispatcher, AND
2. The work is confined to interlocking limits, AND
3. No other MW equipment is involved, AND
4. The track or catenary structure is not disturbed to the extent that a restriction on movements would be required if it were necessary to clear the equipment performing the work.

Movements will be governed by Interlocking Rules. If necessary to make shifting movements outside of interlocking, the applicable rules will apply.

132-S2. BRIDGE STRIKES

Unless otherwise instructed, trains notified that this Special Instruction is in effect must operate at **Restricted Speed** over the bridge specified, or between the locations named.

As used in this Special Instruction, a "bridge strike" is defined as **any** physical contact between a vessel or vehicle and the track supporting portions of an undergrade bridge, excluding contact with the fender system of a bridge over a waterway or the

132-S2. (Cont'd)

abutment or wing-wall of a bridge over a highway.

Train Dispatchers who are advised of an alleged bridge strike must immediately take the following actions:

1. If the bridge is on the Critical Bridge List (see list below), hold all trains clear of the bridge.
2. If the bridge is **not** on the Critical Bridge list:
 - a. Instruct the crews of affected trains to add the location of the restriction on the pre-printed "Bridge Strike" line at the bottom of their TSRB, in accordance with TSRB addition procedures outlined in SI 1-S4, page 269.

or

- b. Issue a Form D (line 13) to crews of the affected trains, in the following format:
Bridge strike SI 132-S2 in effect at/between [location(s)].
3. Continue to provide the protection described in item 1 or 2 above until the bridge has been released by the Division Engineer, or his duly appointed representative.

NOTE: A bridge number can be used to designate the location of the restriction only when the number is clearly stenciled on the bridge, and the number conforms to the bridge's approximate mile post location. Otherwise, the restriction must extend between the first readily identifiable physical characteristic locations on each side of the bridge. As an alternative to the bridge number, the street name used in conjunction with the mile post can be used to designate the location of the restriction so long as the street name and mile post is marked on or at the bridge.

On the PW, PH and NYP Lines, **bridge markers** have been placed between all tracks Phil–Ragan and Overbrook–Paoli, and adjacent to 2 & 3 tracks Zoo–Holmes, to aid in bridge identification. Employees must use care when walking on the right of way at these locations.

On the NYP Line, signs with bridge numbers conforming to MP location and/or street names are located on catenary poles at:

Street Name	City	Location
Edison Place	Newark, NJ	MP 8.77
Chestnut St.	Newark, NJ	MP 9.39
South St.	Newark, NJ	MP 9.64
Murray St.	Newark, NJ	MP 9.84
McClellan St.	Newark, NJ	MP 12.37
North Ave	North Elizabeth, NJ	MP 12.98
Fairmont Ave	Elizabeth, NJ	MP 13.36
Wood Ave	Linden, NJ	MP 17.26
Stiles St.	Linden, NJ	MP 17.65
Evergreen Road	Edison, NJ	MP 24.08
Parsonage Road	Menlo Park, NJ	MP 24.38
Port Reading RR	Metuchen, NJ	MP 24.56
Grove Ave	Metuchen, NJ	MP 25.32
Main St.	Metuchen, NJ	MP 25.84
Lake St.	Metuchen, NJ	MP 26.05
Suydam St	New Brunswick, NJ	MP 31.80
Deans Lane	South Brunswick, NJ	MP 38.60

132-S2. (Cont'd)

CRITICAL BRIDGE LIST

(All listed bridges are movable except Gunpowder River and Niagara Whirlpool)

NHB Line: Conn, Nan, Shaws Cove, Groton (Thames), and Mystic River.

NYS Line: Pelham Bay;

HUD Line: Inwood (Spuyten Duyvil), LAB;

NGB Line: Niagara Whirlpool

NYP Line: Portal and Dock;

PW Line: Susquehanna River, Bush River, Gunpowder River (Gunpow).

133-S1. PROTECTION OF OUT-OF-SERVICE TRACKS

When a track governed by block system or interlocking rules is removed from service by Form D Line 4, the **Foreman issued the Form D must ensure** that each of the following safeguards are taken **prior to beginning work**. When C&S assistance will be required as prescribed below, the Foreman must request this assistance **prior** to obtaining the Line 4.

Exception: When work is performed exclusively with the following equipment, the safeguards prescribed below are not required: Work Trains, MDZ (coupled or separate), TLM, 08-Unimat Switch Tampers, 09-4S Combo Tampers, BMS, Plasser Undercutters, Sperry Cars, Catenary Maintenance Car (MTW-100), Switch Exchange System (SES), Rail Grinding Trains, MPMV (coupled or separate), Brandt Truck (with or without cars), MMU-1000 (coupled together with the material car and working car), TSAV, ATIV, CSXT GRMS 1 & GRMS 2, and NJT-TGIV.

1. A shunting barricade must be erected at each end of the work area within the Line 4 limits and locked into position with a private lock. A non-shunting barricade consisting of two crossed ties or a "Non-Shunting Barricade" sign may be substituted for a shunting barricade when only a portion of a track within interlocking limits is removed from service.

When only a portion of a track within interlocking limits is removed from service, a C&S employee must approve the location of the barricades and must remain available to establish desired routes, if necessary.

2. It must be determined that the track at each end of the work area is shunted. In ABS territory, this may be determined by visual observation of the last automatic block signal leading to the work area in both directions. (In Rule 251 territory, no confirmation of shunt is required for movements against the current of traffic.)

If the work area is in or near interlocking limits, shunt may be verified by confirming with the Operator or Dispatcher that a track occupancy light is displayed on his interlocking machine in the appropriate location(s).

3. If the work area cannot be protected by Panel Blocking Devices, a C&S employee must de-energize the track circuits for the work area. This requirement is in addition to the above barricade requirement. Work in the following areas **cannot** be protected by Panel Blocking Devices, and therefore requires C&S employee assistance:

a) Work **within** the following interlocking limits: **NHB Line**—Read, Forest, Plains; **NYS Line**—Pelham Bay; **NYT Line**—"Q"; **NYP Line**—Dock, Iselin, Menlo, Ham, Zoo; **PW Line**—Zoo, Penn (Except: 1 & 4 trks 36th St. Connection; N5 & N3 routes, 1 & 4 River Line trks between MP 1 & Spring Garden St; 10 trk pocket; 7 lead; 1 & 4 River Line trks between Walnut & South Sts), Phil, Bell-Ragan inclusive, Ruthby (except trk 1), Davis-Perry inclusive, Oak-Bridge inclusive, Winans (except trk 1), Grove, Bowie, Landover; **PH Line**—Zoo, Valley, Overbrook, Paoli, Glen, Downs, Thorn, Caln, State (*except* trks between int signals west of Harrisburg station have panel blocking).

133-S1. (Cont'd)

b) Work in the **ABS** territory adjacent to any of the following interlockings:

PH Line: Caln, Downs, Glen, Overbrook (no panel blocking eastward on Tracks 1, 2 and 4, nor westward on Track 3), Paoli (no panel blocking eastward on Track 3), State, Thorn, Valley, and Zoo.

Exception: In Washington Terminal, de-energizing of track circuits is not required. When only a portion of an interlocking or Station Track in Washington Terminal is out of service by Form D Line 4 or Bulletin Order, a C&S employee must ensure the signal leading to the out-of-service portion will not display an aspect more favorable than Restricting.

Prior to cancellation of Form D, the Foreman must ensure that barricades are removed and track circuits restored to normal.

133-S2. ADMITTING ADDITIONAL EQUIPMENT

The Dispatcher or Operator may admit additional track cars or trains to the out-of-service limits after obtaining permission of the employee named in the Form D Line 4.

When authorizing additional equipment to enter an out of service track, the Foreman named on Form D Line 4 must advise the employee in charge of the additional equipment of all conditions affecting movement on the out-of-service track, including the location of barricades, *Roadway Workers*, equipment, and the condition of the track structure.

The Foreman must ensure that any barricades removed to admit the additional equipment are reapplied, and their shunt verified, as soon as the equipment enters the work area.

Track cars and trains that clear an out-of-service track must obtain permission from the Foreman before re-entering the out-of-service track.

133-S3. FOREMAN GOING OFF DUTY

When a track is out of service by Form D Line 4, and the Foreman in charge is to go off duty, Form D Line 4, must be issued to another qualified Foreman if work is to continue.

If work is to be suspended, but track must remain out of service to protect equipment or track conditions:

1. The Dispatcher must ensure that Blocking Device protection remains applied. Operators involved must be issued Form D, Line 13, instructing them to hold all trains clear of the affected track.
2. The Foreman addressed must ensure that barricades erected to protect non-shunting equipment or track conditions are repositioned adjacent to non-shunting equipment and/or track requiring protection, and must verify that repositioned barricades shunt properly as per SI 133-S1.
3. The Foreman must then contact the Dispatcher and Track Supervisor in charge of the territory involved to advise them of all conditions affecting the out of service track area, to include the locations of barricades, equipment, and condition of track structure. This information must be recorded by the Dispatcher, and repeated back to the Foreman.
4. After steps 1, 2, and 3 are completed, the Form D, Line 4 must be canceled.

No further movements shall be permitted or maintenance performed on affected track until Form D, Line 4 is issued to a qualified Foreman, or Conductor as specified in S.I. 133-S4. Before requesting Form D, Line 4, Foreman must communicate with the Dispatcher and Track Supervisor in charge of the territory involved to ascertain all conditions affecting the out of service track area.

Upon completion of work, the provisions of steps 1 through 4 above will apply, if

133-S3. (Cont'd)

track must again remain out of service to protect equipment or track conditions.

EXCEPTION: Conductors need only comply with the procedures contained in step 3 above, and need only contact the Dispatcher.

The Dispatcher must provide information regarding all conditions affecting the out of service track area, to include the location of barricades, equipment, and condition of track structure, to the next Foreman or Conductor who obtains Form D, Line 4 to perform maintenance in the affected track area.

133-S4. WORK, WRECK OR WIRE TRAINS

The Train Dispatcher may issue a Form D to the Conductor of a Work, Wreck, or Wire Train when both of the following conditions have been met:

- There is no qualified Foreman on the train, AND
- No track cars will occupy the out-of-service limits, except as provided for in NEC Special Instruction 133-S3, which allows **unattended** track cars to be stored on a track when the Foreman responsible for their operation goes off duty.

Once the Conductor receives the Form D Line 4, he or she may authorize other trains (but not track cars) into the out-of-service limits in accordance with Rule 133. Work that will disturb the track or catenary structure so that it would be unsafe for Normal Speed must not be performed unless the track is removed from service in the name of a qualified employee.

133-S5. HIGHWAY CROSSINGS ON OUT-OF-SERVICE TRACKS

In the application of Rule 138(g), trains operating on an out-of-service track must not foul a highway crossing equipped with automatic warning devices until it is ascertained that the warning devices have been operating at least 20 seconds, or the gates (if equipped) are in the horizontal position. If the automatic highway crossing warning devices are not operating, the movement must not be made until protection is provided by on-ground personnel.

133-S6. REMOVING A TRACK FROM SERVICE: FORM D ADDRESS

When an Engineering Department employee requests use of the track, he or she will be identified in the address of the Form D removing the track from service as a "Foreman," plus his or her last name.

133-S7. C&S SIGNAL TESTING ON TRACKS OUT OF SERVICE BY FORM D LINE 4

In the application of Rule 133.a, a signal leading to or within the limits of an out of service track may be displayed only when necessary for C&S testing, as follows:

Prior to removing blocking devices the Dispatcher must:

1. Conduct a job briefing with the employee listed on Line 4 to ensure a definite understanding of the testing to be performed.
2. Ensure blocking devices are applied to prevent movement in the direction of the signal to be displayed.
3. Verify that no train or on-track equipment is authorized in the direction of the signal to be displayed.

Exception: Step 3 is not required when the track is out of service on both sides of the signal to be displayed.

The Dispatcher must immediately restore the signals to Stop and reapply blocking devices once testing is complete.

136-S1. FREIGHT TRAINS OPERATING WITHOUT A CABOOSE

Freight trains operating without a caboose that experience a radio failure enroute must reduce speed to 30 MPH and stop at first point of communication to contact the Dispatcher for instructions.

The Dispatcher must not allow the train to proceed until absolute block protection is established for trains moving in the same direction on adjacent tracks.

Once absolute block protection is established, the train may be instructed to proceed at normal speed governed by signal indications. If thereafter an emergency application of the brakes occurs, crew members are relieved from providing flag protection against following movements on adjacent tracks.

136-S2. LIGHT ENGINE MOVEMENT

Should the locomotive radio become inoperative enroute on a light engine movement operated solely by an Engineer (no other crew members on train), the speed of the movement must be reduced to 30 MPH. Dispatcher must be notified at first point of communication, and Engineer will be governed by his instructions.

HIGHWAY CROSSINGS AT GRADE

138-S1. STATE OF CONNECTICUT

Where there are public crossings involved, the following rule must be complied within the State of Connecticut.

1. Where adequate run around facilities are available at the point where reverse movement is to be made, and use of such facilities is practicable, train backing movements are prohibited.

2. When train backing movements are necessary due to lack of adequate run around facilities at the point from which backing movements are to be made, such backing movements must stop before entering all public crossings that are protected by signs only and a member of the crew shall flag the train over the crossing.

If adequate run around facilities are available for use at any point during train backing movements, and use of such facilities is practicable, such run around facilities must be used to eliminate the need for further backing movements.

These provisions will not apply to switching backing movements except that such backing movements over public crossings that are protected by signs only must be protected by a crew member.

138-S2. MASSACHUSETTS

In the State of Massachusetts, where gates are provided trainmen, track car driver or employee in charge of other rail movements must operate the gates of unattended grade crossings. At highway grade crossings protected by automatic gates, all rail movements not equipped to operate automatic gates must not pass over such crossing until gates have been operated.

138-S3. BLOCKING PRIVATE CROSSINGS

Trains on sidings blocking private crossings must be patrolled by trainmen and train cut if anyone desires to use private crossing. This does not relieve trainmen of cutting train for public road crossings immediately.

138-S4. HIGHWAY CROSSING WARNING DEVICE MALFUNCTIONS

In the application of Rule 138, part “c”, the first five paragraphs(entire portion above table), are revised as follows:

Notify the Dispatcher immediately if you discover automatic highway crossing warning devices that are not functioning properly.

Once notified of malfunctioning automatic highway crossing warning devices, the Dispatcher must:

1. Issue Form D Line 12 to all trains that will operate over the affected crossing, indicating the name and milepost of the crossing as identified in the applicable special instruction.

AND

2. Ensure that notification is provided to the local law enforcement agency or railroad police.

Unless otherwise instructed on Form D Line 13, crews must comply with the “Requirements” listed in Item 1 of Rule 138 part “c”: Stop, make certain that a crew member provides on-ground warning at the crossing, then proceed not exceeding 15 MPH until the leading end operates through the crossing.

When the Dispatcher is notified that rust or other foreign matter may prevent effective shunting, trains must be instructed to comply with the “Requirements” listed in Item 1 of Rule 138 part “c”, unless flagger or a railroad police officer is providing warning at the crossing.

The appropriate engine whistle or horn signal must be sounded at locations where automatic highway crossing warning devices are not functioning properly, including crossings where a whistle sign indicating “W/R” is displayed, and in areas otherwise designated as Quiet Zones.

139-S1. TRAINS, CAR(S) OR OTHER ON-TRACK EQUIPMENT LEFT UNATTENDED ON MAINLINE TRACK OR MAINLINE SIDING

1. Definitions

As used in this instruction:

- a. A mainline track is any track governed by ABS rules, DCS rules or Interlocking rules.
- b. A mainline siding is an auxiliary track, adjacent and connected to a main track, used for meeting or passing trains.
- c. Designated terminals include Boston South Station, Springfield, New York Penn Station, Newark Penn Station, Trenton, 30th St. Station, Baltimore Penn Station, Washington Union Station, Albany, and Harrisburg.

2. Authorization Required

In the application of Rule 139, leaving a train, car(s) or on-track equipment unattended on a mainline track or mainline siding outside of designated terminals is prohibited unless authorized by the Train Dispatcher.

The Train Dispatcher must not authorize equipment to be left unattended on a mainline track or mainline siding outside of designated terminals except:

- a. To allow pick-ups or set-offs at industry tracks, or permit the repositioning of equipment at other locations when operationally necessary (e.g. run around equipment); or
- b. An emergency situation exists, such as equipment failure or extreme weather conditions; or
- c. An extended maintenance project requires the equipment to be stored when workers are off duty.

139-S1. (Cont'd)

3. Job Briefing Requirements

Prior to leaving equipment unattended on a mainline track or mainline siding, crews must conduct a job briefing in accordance with the applicable section of Special Instruction 4-S1.

4. Securement Requirements

Trains, car(s) or on-track equipment left unattended on a mainline track or mainline siding must be secured in accordance with the securement procedures for that equipment. Amtrak employees must secure the equipment in accordance with the applicable Amtrak securement procedures. Non-Amtrak employees must follow the securement procedures specified by their employer. A qualified employee must test the securement to ensure it is sufficient to prevent unintended movement prior to leaving the equipment unattended.

When a train is left unattended on a mainline track or mainline siding with the locomotive, the controlling locomotive cab must be locked if possible. If not possible to lock locomotive door, the reverser must be removed from the control stand and secured.

Prior to leaving any such equipment unattended outside of designated terminals:

- a. A qualified employee who participated in the securement, or who has knowledge of the procedures that were followed, must verify with the Train Dispatcher that the required securement procedures have been followed and the securement has been tested and is known to be effective.
- b. The Train Dispatcher must confirm receipt of the information that the equipment has been secured properly.

5. Reporting Requirements When Certain Hazmat Cars Are In The Consist

A qualified employee who participated in the securement, or who has knowledge of the procedures that were followed, must communicate the specific information included in this section to the Train Dispatcher if their train's consist includes:

- a. Five or more tank car loads of any one or any combination of materials poisonous by inhalation as defined in 49 CFR 171.8, including anhydrous ammonia (UN 1005) and ammonia solutions (UN 3318); or
- b. 20 rail car loads or intermodal portable tank loads of any one or any combination of materials listed in (a) above, or,
- c. Any Division 2.1 flammable gas, Class 3 flammable liquid or combustible liquid, Class 1.1 or 1.2 explosive, or hazardous substance listed in 49 CFR 173.31(f)(2).

The communication must include:

- a. The number of hand brakes applied, and chocks, if used;
- b. The tonnage and length of the train or vehicle;
- c. The type and location of cars containing hazardous materials;
- d. The grade and terrain features of the track, such as an ascending or descending grade;
- e. Any relevant weather conditions.

6. Train Dispatcher's Record

Train Dispatchers must record the information provided if the equipment to be left unattended includes:

- a. Five or more tank car loads of any one or any combination of materials poisonous by inhalation as defined in 49 CFR 171.8, including anhydrous ammonia (UN 1005) and ammonia solutions (UN 3318); or
- b. 20 rail car loads or intermodal portable tank loads of any one or any combination of materials listed in (a) above, or,

139-S1. (Cont'd)

- c. Any Division 2.1 flammable gas, Class 3 flammable liquid or combustible liquid, Class 1.1 or 1.2 explosive, or hazardous substance listed in 49 CFR 173.31(f)(2).

7. Requirements When Emergency Responders Work on Equipment

Prior to leaving trains, car(s) and other on-track equipment unattended, it must be inspected by a qualified employee when it is known that an emergency responder was on, under, between, or otherwise manipulated the equipment. Any Amtrak employee who has knowledge of an emergency responder being on, under, between or otherwise manipulating equipment must report their observation to the Train Dispatcher.

140-S1. FOUL TIME

In the application of Rule 140, Foul Time information must be recorded by the Dispatcher or Operator issuing the foul time, and recorded by the employee requesting the foul time on form NRPC 3045 "Authority to Foul Tracks Record".

Before allowing additional employees to join the work being performed under Foul Time permission, the employee who was granted Foul Time by the Dispatcher must conduct a job briefing with the additional employees, and must review the track(s) being protected, the Foul Time track and time limits, and all other factors affecting the work. The additional employees must not be permitted to foul the track(s) involved until they have verified their full understanding of all topics discussed during the job briefing.

140-S2. USE OF SUPPLEMENTAL SHUNTING DEVICE

This instruction requires the employee in charge of "covered fouling activities" to apply an approved Supplemental Shunting Device (SSD) to the track(s) to be fouled, after receiving foul time from the Dispatcher or Operator. The purpose of the SSD is to **supplement, not replace**, blocking device protection provided by the Dispatcher or Operator.

A. Covered Fouling Activities:

This instruction does **not** apply when the fouling activity:

1. Requires Form D line 4 or line 5 authority,

or

2. Is within the approach circuit to a highway crossing that is not equipped with a device that will automatically interrupt the operation of the crossing's warning devices (i.e., any crossing listed in Special Instruction 138 that does **not** have an "X" in Column 1 of that instruction),

or

3. Is within 200 feet of any highway crossing that is equipped with automatic warning devices.

Note: Roadway Workers performing service without equipment may elect to use an SSD. Roadway Workers electing to use an SSD must do so in accordance with sections "B" and "C" of this instruction.

140-S2. (Cont'd)

B. Actions to Be Taken Before Performing Covered Fouling Activities: The following requirements apply to **each track** to be fouled. The person in charge of the work must take the following actions **before** permitting the fouling activity to begin.

- 1. Obtain verbal permission to foul the track from the Dispatcher or Operator.**
- 2. Fouling Within Interlocking Limits:** For the purpose of this instruction, a “signal pocket” is defined as a section of track located between two interlocking signals that govern movement out of the pocket, with no switches between the two signals. Signal pockets are usually found where a passenger station exists within interlocking limits. Signal pockets are designed to allow the Dispatcher to route other trains around a train that is making a station stop or standing in the pocket.
 - a. Fouling Within Signal Pocket** – When track is to be fouled within a “signal pocket”, SSD will be applied within that interlocking signal pocket.
 - b. Fouling Outside of Signal Pocket** – When necessary to foul an interlocking track that is not located within an interlocking “signal pocket”, **prior to beginning work**, the employee in charge of the fouling activity must contact the Division Engineer or his designated C&S Department representative to determine the location(s) at which SSD device(s) must be applied within interlocking limits. SSD device(s) must then be applied within interlocking limits at the previously approved location(s).
 - c.** Verify that the track is shunted by asking the Dispatcher or Operator if there is a track occupancy light (TOL) on the model board in the appropriate location.
- 3. Fouling Outside Interlocking Limits:** For the purpose of this instruction, a “block” is defined as a length of track between fixed signals.
 - a.** If only **one block** will be fouled, apply a SSD to the track in the block to be fouled.
 - b.** If **more than one** block will be fouled, be governed as follows:
 - On a Rule 251 Track, apply a SSD in the first block to be fouled (or in the block prior to that block), as determined by a train operating with the current of traffic.
 - On a Rule 261 Track, apply a separate SSD in each block to be fouled.
 - c.** Verify that the track is shunted by observing that the signal governing entrance to the block is displaying Stop Signal, Stop and Proceed, or Restricting, or asking the Dispatcher or Operator if there is a track occupancy light (TOL) on the model board in the appropriate location.

C. Actions to Be Taken Before Reporting Clear: Before reporting clear of the track to the Dispatcher or Operator, the employee in charge of the work must remove the shunt(s) by either:

- 1.** Disconnecting the coupler in the middle of the SSD

or

- 2.** Removing the SSD from the track.

The SSD must be removed from the track when reporting clear for last time.

FORM D RULES

161-S1. APPROVED ABBREVIATIONS

The following abbreviations are approved for use in movement Permit Form D:

DB	Dorchester Branch
HUD	Hudson Line
LLC	Lehigh Line Connection
MRS	Main Line—Mill River to Springfield
MM	Middleboro Main Line
MV	New Jersey Transit Morrisville Line
NGB	Niagara Whirlpool Bridge
NHB	Main Line—New Haven to Boston
N Phila	North Philadelphia
NYP	Main Line—New York to Philadelphia
NYS	Main Line—Harold to CP 216
NYT	New York Terminal District
PH	Main Line—Philadelphia to Harrisburg
PRB	Post Road Branch
PSCC	Penn Station Central Control
PW	Main Line—Philadelphia to Washington
TSRB	Temporary Speed Restriction Bulletin
WT	Washington Terminal
36SC	36th St Connection

165-S1. FORM D INQUIRY AND DELIVERY PROCEDURES

At the following locations, Conductors/Engineers of trains indicated must contact the Dispatcher or Operator to inquire about Form D's, TSRB changes, Supplemental Bulletin Orders, and other new instructions. Inquiry must be made sufficiently in advance to avoid delay to train, ***but must not be made prior to scheduled sign-up time***. Conductor/Engineer must either deliver Form D's and/or other new instructions to the Conductor/Engineer, or notify Conductor/Engineer that no Form D's and/or new instructions are in effect. Engineers must not depart until Form D and new instruction status has been verified with Conductor.

Conductors and Engineers must discuss Form D content before departing. Telephone numbers for Amtrak offices are listed in S.I. 714-S1 (see page 350).

165-S1. (Cont'd)			
Location	Trains	Dspr or Opr to contact	Notes
Boston	All Trains	Chief Dispatcher	2, 7
	Regional & Acela Express	Metro-North & Amtrak New York Chief Dispatchers	14
	Trains destined New Haven	Metro-North Chief Dispatcher	12
	Trains destined Springfield	CSX Boston Dspr- Selkirk	2, 4
Springfield Ticket Office	Southward Trains	Amtrak & Metro- North Chief Dispatchers	2, 7, 12
New Haven	Eastward & Northward Trains	Boston Chief Dispatcher	2, 7

165-S1. (Cont'd)

Location	Trains	Dspr or Opr to contact	Notes
New Haven	Westward Trains	New York Section A Dispatcher	13
New Haven	Trains destined Boston via Springfield	CSX Berkshire Dspr-Selkirk	2, 5
Boston, Springfield Niagara Falls, Buffalo Depew, Syracuse, Montreal PQ, Rouses Point, Rutland VT, Albany-Yard Master's Office	All trains destined: Niagara Whirlpool Bridge, Post Road Branch, Hudson Line	Amtrak Hudson Line Dspr	1, 8
Croton Yard, Oak Point Yard, Selkirk TM, Selkirk Div. Ops., South Schenectady Yard, West Albany Yard	CSX Freight trains destined Hudson Line		
New York - TOC	All trains not destined Sunnyside Yard, including trains operating from New York en route to Harrisburg that do not change crews at 30 th St. Station, Phila.	Passenger Operator	6, 8
	Eastward Trains to Boston	Psgr. Opr., Metro-North Chief Dispatcher, Boston Chief Dispatcher	6, 7, 8, 12
	Eastward Trains to New Haven	Psgr. Opr. & Metro-North Chief Dispatcher	6, 8, 12
Q Tower	Road Trains destined New York	Passenger Operator Station Master's Office	6, 8, 11
Lane	Trains originating	Opr Dock	8
County	Trains originating	CETC 8 Dspr	8
Trenton Station Master's Office	Trains originating at Trenton	CETC 7 Dspr	1, 8
Morris	Trains originating	CETC 7 Dspr	8
Location	Trains	Dspr or Opr to contact	Notes
30th St Station	Trains originating at 30 th St. Station, except those destined Penn Coach Yard or Race St. Engine Terminal	CETC 5 Dspr	9
	Trains that change crews at 30 th St. Station, and operate from Harrisburg en route to New York, or operate from New York en route to Harrisburg.	CETC 5 Dspr	10
Frazer Yard	Trains originating at Frazer or Glen	Train Director - Thorn	1

165-S1. (Cont'd)

Location	Trains	Dspr or Opr to contact	Notes
Harrisburg	All eastward trains, including trains that operate from Harrisburg en route to New York that do not change crews at 30th Street Station, Phila.	Train Director - State	...
Abrams, Bayview, Bennings, Chrysler, Edgemoor, Enola, Frankford Jct, Harrington, Harrisburg, Lancaster, and South Philadelphia Yards	Conrail & NS trains operating between: Holmes & CP Avenue and Glen & Harrisburg	Dspr or Opr controlling entrance to Amtrak Territory	1
Perry	MARC trains originating or turning at Washington, Baltimore, Martins, or Perry	CETC-3 TD	3
Baltimore-Psgr Services Office, and Martins MARC Facility		CETC-2 TD	1, 3
Washington-K Tower		Train Director - K Tower	1, 3
Washington-Crew Dspr Office	Northbound Amtrak trains	Train Director - K Tower	1

NOTE 1: Form D's are **electronically transmitted** to this location. CONDUCTORS must examine Form D's for completeness and legibility, contact the Dispatcher or Operator to verify the number and date of each Form D received, and then complete the delivery portion of the first Form D prior to delivering the Form D's to their engineer.

ENGINEERS must not depart until ensuring that the delivery portion is completed on the first Form D, and that the information shown in the delivery portion corresponds with the Form D's received.

NOTE 2: Form D's are **electronically transmitted** to this location. ENGINEERS must examine Form D's for completeness and legibility, contact the Dispatcher to verify the number and date of each Form D received, and then complete the delivery portion of the first Form D prior to delivering the Form D's to their CONDUCTOR.

NOTE 3: Form D's will be addressed to "MARC trains operating between Perry and Washington" and will remain in effect, unless cancelled, for all trips made by each crew during the tour of duty on which they were received.

NOTE 4: Commercial phone number (518) 767-6111.

NOTE 5: Commercial phone number (518) 767-6112.

NOTE 6: Conductor/Engineer must report to TOC prior to their train's departure time. They must fill out all required information on the TOC Record of Inquiry.

NOTE 7: Boston Chief Dispatcher, Phone (ATS) 580-7585 Commercial (617) 345-7585.

NOTE 8: Conductors must not inquire about Form D's and/or other new instructions that may be in effect for their train prior to the scheduled sign-up time.

NOTE 9: All trains originating 30th St. Station will obtain their Form D's in the sign-up room across from the T&E lounge (adjacent to valet parking window), and Note 1 will apply.

NOTE 10: Crews for these trains will obtain their Form D's in the sign-up room across from the T&E lounge (adjacent to valet parking window), and Note 1 will apply.

165-S1. (Cont'd)

NOTE 11: Road Conductors signing up at Q Tower, Sunnyside Yard, must call the Operator at the Terminal Operations Center (TOC) to inquire about Form D's and/or new instructions that may in effect for their train, which will be faxed to Q Tower. Upon arrival in New York, Note 6 above applies.

NOTE 12: Conductor/Engineer must contact the Metro-North Chief Dispatcher (800-724-3004 or 212-340-2050) to confirm they are in possession of the current Bulletin Orders, D.T.O.B.Os, Form Ms and other instructions pertaining to their train.

NOTE 13: Conductor/Engineer must contact the New York Section A Train Dispatcher (ATS 521-7472 or 212-630-7472) to confirm they are in possession of the current Bulletin Orders, Form Ds, TSRBs, and other instructions pertaining to their train.

NOTE 14: Conductor/Engineer must contact the Metro-North Chief Dispatcher (800-724-3004 or 212-340-2050) and the New York Chief Dispatcher (ATS 521-7465 or 212-630-7465) to confirm they are in possession of the current Bulletin Orders, D.T.O.B.Os, Form Ms, Form Ds, TSRBs, and other instructions pertaining to their train.

165-S2. FORM D's FOR SEPTA TRAINS

A Form D which has been **addressed** for use "Between", meaning both directions, will be retained on that train for use in the opposite direction. Form D will be fulfilled after **1** round trip.

SEPTA Trains possessing Form D's containing Amtrak main line restrictions will verify at turnaround locations that there are no additional Form D's for the return trip.

175-S1. TEMPORARY SPEED RESTRICTIONS BEGINNING OR ENDING AT AN INTERLOCKING

When an interlocking is used as one of the limits of a temporary speed restriction, the speed restriction will not apply within the interlocking, unless otherwise specified on the Form D or TSRB issuing the speed restriction.

175-S2. "80 MPH SLOW BY" SPEED RESTRICTION

When an Undercutter or TLM is working on an out-of-service track, an "80 MPH Slow By" Form D will always be issued to trains operating on tracks immediately adjacent to the **TLM**, but will be issued on tracks immediately adjacent to the **Undercutter** only when requested by the MW employee in charge. The Form D will be issued in the following format:

"Do not exceed 80 MPH on No. ___ track(s) ___ Line between ___ and ___ between the hours of ___ and ___ Speed signs will be displayed Speed restriction applies to head end only."

The speed restriction applies only between the hours prescribed. The time period must begin and end on the hour or half hour. Speed signs must be erected at the start time and removed at the end time. The Form D must be canceled at delivery points once the end time has been reached. Crews who encounter speed signs displayed outside the specified time period should comply with the signs and report the discrepancy to the Dispatcher.

When track work is completed each day, the MW employee in charge must provide the Dispatcher with the limits, times and date for the following work day's 80 MPH speed restriction. On the next day, the MW employee in charge must confirm this information with the Dispatcher.

177-S1. OVERLAPPING TEMPORARY SPEED RESTRICTIONS

Dispatchers must take the following actions when issuing a temporary speed restriction by Form D or TSRB addition that changes any portion of a previously issued Form D or TSRB:

1. Issue a Form D line 1 or TSRB addition to cover the entire affected track area.
- AND
2. Issue a Form D line 13 or TSRB line cancellation to cancel the previously issued speed restriction(s).

EXCEPTION: These procedures are not required when issuing a temporary speed restriction of a short duration or emergency nature (e.g., heat order, rough track, bridge strike, etc.).

When two or more temporary speed restrictions overlap or conflict, employees will be governed by the more restrictive speed.

241-S1. PASSING A STOP SIGNAL

In the application of Rule 241, item b, Restricted Speed applies to the entire train.

241-S2. STOP SIGNAL PROTECTING MOVABLE BRIDGE: QUALIFIED EMPLOYEE

When an inspection of a movable bridge is required by NORAC Rule 241(d), the inspection must be performed by a qualified Engineering Department employee.

242-S1. IMPERFECTLY DISPLAYED SIGNALS

When reporting imperfectly displayed position light signals or color position light signals, the chart shown below must be used to identify missing lights by number.

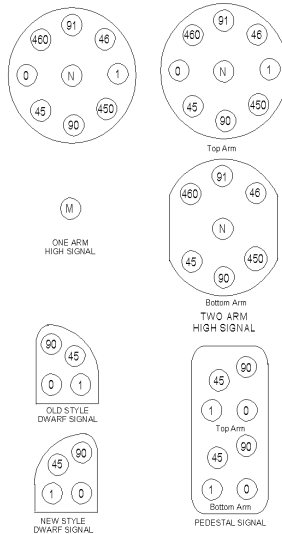

279-S1. NEW JERSEY TRANSIT EQUIPMENT–NON-CONFORMING CAB SIGNAL ASPECTS

Cab signal units on some NJ Transit engines and control cars display the number “80” on a lighted steady green or lighted steady yellow background to indicate Cab Speed; or a black “45” with a yellow background to indicate Approach Medium.

279-S2. CAB SIGNAL ASPECTS & DISPLAY UNITS

Various engines and control cars are being equipped with a new cab signal display unit, which displays the speed enforced by the cab signal aspect. The new units, in conjunction with new cab signal codes that are being phased in over the next several years, will display up to ten different cab signal aspects - Clear 150, Clear 125, Clear 100, Cab Speed 80, Cab Speed 60, Approach Limited 45, Approach Medium 45, Approach Medium 30, Approach 30, and Restricting 20.

279-S3. CAB SIGNAL ASPECTS: RESTRICTING

A red over white cab signal is added to the aspects that conform to a Restricting Signal.

Name	Aspect
Restricting	 red white

287-S1. SLOW CLEAR INDICATION

Where interlockings are back-to-back (i.e., one interlocking ends where the other begins), trains receiving a Slow Clear signal to operate from one back-to-back interlocking to the other must, after clearing all interlocking switches at the first interlocking, approach the home signal for the second interlocking at Slow Speed.

290-S1. RESTRICTING SIGNAL

In the application of Rule 290, Restricted Speed applies to the entire train.

291-S1. STOP AND PROCEED SIGNAL

In the application of Rule 291, Restricted Speed applies to the entire train.

296-S1. APPROACH PERMANENT SPEED LIMIT SIGN

Rule 296, "Approach Permanent Speed Limit Sign," is revised as follows:



Fig. A



Fig. B

(Black numbers or letters on yellow background)

NAME: Approach Permanent Speed Limit Sign

INDICATION: Proceed prepared to operate at prescribed speed through permanent speed restriction. If speed posted on sign is different than authorized Timetable Speed, Timetable Speed will govern.

Note: In electrified territory, this sign will be mounted in the catenary system or on catenary poles. In non-electrified territory, this sign will be mounted on an overhead bridge or on a pole approximately 12 feet above the top of the rail.

296a-S1. APPROACH SPEED LIMIT SIGN

Approach Speed Limit signs for speed restrictions for passenger train types "C" and "D" will have "CD" marked on the sign above the numerals.

296c-S1. DISPLAY OF RESUME SPEED SIGN

If two or more temporary speed restrictions adjoin each other, only one Resume Speed Sign will be used. That sign will be displayed at the end of the final restriction. Trains will be governed by the TSRB or Form D in their possession.

FORM D CONTROL SYSTEM

400-S1. MOVEMENTS IN DCS TERRITORY

In the application of Rule 400, Dispatchers issuing Form D line 2 for movement in DCS territory may use any station or whole mile post as the end point of the line 2 authority. Before issuing Form D line 2, however, the Dispatcher must ensure that the track to be used is clear to the next interlocking, controlled point or TBS. Four exceptions are:

1. When the authority is written to the end of a main track which ends at a point other than an interlocking, controlled point or TBS.
2. When a portion of the main track ahead of the movement is out of service in accordance with Rule 134.
3. When authorizing an engine to assist a disabled train in accordance with Rule 137.
4. When authorizing a train to pick up unattended equipment in accordance with Rule 139.

401-S1. NON-INTERLOCKED FACING POINT SWITCHES

Trains operating under the DCS rules must not pass over non-interlocked facing point switches until it is ascertained that the switch is properly lined.

401-S2. OPERATING IN NON-SIGNALED DCS TERRITORY: MAXIMUM AUTHORIZED SPEED

NORAC Rule 401(a) has been revised to comply with the Federal requirements in 49CFR Part 236.0 reducing the maximum authorized speeds.

401. Operating in Non-Signaled DCS Territory

a. Maximum Authorized Speed

Passenger trains must not exceed 59 MPH and freight trains must not exceed 49 MPH, unless otherwise restricted.

500-S1. SPEED ENTERING ABS BETWEEN SIGNALS

In the application of Rule 500, paragraph c, Restricted Speed applies to the entire train.

CAB SIGNAL SYSTEM

550-S1. AUTOMATIC TRAIN CONTROL SYSTEM

All trains operating on the Northeast Corridor must be equipped with an Automatic Train Control (ATC), Speed Control or Locomotive Speed Limiter system (LSL) that will enforce cab signal aspect speeds. The ATC, Speed Control or LSL must be cut in and functioning whenever movement is governed by *ABS or interlocking rules*, regardless of whether cab signal rules are in effect on the track. Four exceptions to this requirement are:

1. Trains that experience a cab signal, ATC, Speed Control or LSL failure en route while operating in CSS territory. (Trains operating in *non-CSS territory* cannot claim an en route cab signal, ATC, Speed Control or LSL failure, unless they have experienced a catastrophic failure of their on-board apparatus, such as a major debris strike that damages their cab signal pickup bar.)

550-S1. (Cont'd)

2. Trains operating within Washington Terminal that are not operating to or from the Main Line—Philadelphia to Washington.
3. Trains operating between Tower 1 and Cove destined to or from CSXT Boston Line.
4. Trains operating against the current of traffic, where DCS rules have been substituted for ABS rules, or where CSS rules have been removed from service in accordance with Rule 561, may cut out their speed control switch or ATC cutout switch through the affected area (P42 & P40 engines must cut out the territory switch). However, speed control, ATC or territory switch must be cut back in immediately before the train leaves the affected area.

NOTE: When operating against the current of traffic on a Rule 251 track, the cab territory switch (if equipped) should be used to cut the speed control out through the affected area. However, when operating where DCS rules have been substituted for ABS rules, or CSS rules have been suspended, the electric ATC cut out switch must be used to avoid penalties that might occur if cab signal flips are received. Whenever a seal is broken to cut out one of these appliances, the Engineer must record the action on locomotive inspection form (MAP 100 for Amtrak engines). When the equipment is cut back in at the entrance to signaled territory, no retest is required, unless the equipment was cut out pneumatically.

AMT-3 Instruction 7.2.1(c), "Territory Switch" is modified accordingly for movements leaving cab signal territory that are still governed by ABS or interlocking rules.

The controlling locomotive of trains operated in the NEC that are equipped with a **Locomotive Speed Limiter (LSL)** system must be equipped with indicating lights on each side that illuminate when the locomotive's LSL system is cut in and functioning properly. If these LSL indicating lights are seen to be extinguished in cab signal territory, the train's LSL system may be cut out or not functioning properly, and immediate notification must be made to the crew of the train involved and to the Dispatcher.

551-S1. ON-BOARD CAB SIGNAL TESTING DEVICE

MARC Control Cars 7745-7749 are equipped with an onboard cab signal testing device, governed by AMT-3 Instruction 7.2.3(A), "ATC (Cab Signal) Self Tester".

551-S2. CAB SIGNAL TESTS

When a cab signal test is performed by an engineer where there are no mechanical forces on duty to receive a copy of the test results, in addition to posting a copy in the locomotive cab, the results of such inspection must be transmitted to the Dispatcher, specifying the location, date, time, train, engine number, engineer's name and test results. The Dispatcher will record the test information in the Record of Cab Signal Test book.

561-S1. SINGLE LITE ACS-64, AEM-7, ALP-44, ALP-46, HHP-8, HST POWER CAR & MU ENGINE MOVEMENTS

In CSS territory, Dispatchers and Operators must not authorize a train to follow a **single lite ACS-64, AEM-7, ALP-44, ALP-46, HHP-8, HST power car or MU engine** between consecutive interlockings or controlled points, or between consecutive signals within interlocking limits.

Exceptions:

1. This restriction does not apply when the equipment is stored on a station track, without a signal to proceed.
2. This restriction does not apply on track Nos. 4 and 5 between Arsenal and Phil, inclusive (PW Line).

561-S1. (Cont'd)

3. This restriction does not apply on the PH Line territory listed below:
 - No. 1 Track, between 52nd St. and eastern limits Zoo Int
 - No. 4 Track, between the eastern and western limits of Zoo Int
 - No. 4 Valley Track, between western limits Zoo Int (44th St.) and Valley Int (52nd St.)
 - No. 2 Track, between connection with K Ladder in Zoo Int (D1) and 44th St (JO).
4. In an emergency, the Dispatcher may authorize a train to follow this equipment by issuing the following train a Form D Line 11 for the territory involved.

Prior to entering cab signal system territory, the conductor or engineer of a **single lite ACS-64, AEM-7, ALP-44, HHP-8, HST Power Car or MU engine** must notify the Dispatcher or Operator, who must in turn notify the next Dispatcher or Operator ahead of the movement. Interlocking and controlled point signals must be displayed for the lite engine movement.

Each Operator or Dispatcher involved must apply blocking devices to his control machine to restrict following movements. These blocking devices need not be recorded nor reported to the Dispatcher. Interlocking machine indication may be relied upon to determine when engine has cleared interlocking or controlled point signals.

580-S1. ACSES RULES

DEFINITIONS

Advanced Civil Speed Enforcement System (ACSES): A transponder and data radio based train control system that supplements the cab signal/speed control system by enforcing permanent speed restrictions, temporary speed restrictions, and a positive stop at interlocking and controlled point signals displaying Stop Signal.

Transponder: A device mounted between the rails that transmits location-specific train control information to trains equipped with on-board ACSES apparatus.

Data Radio: A radio used on-board ACSES equipped trains and at fixed sites to enhance certain features of ACSES through transmission and reception of data.

ACSES RULES

Advanced Civil Speed Enforcement System (ACSES) Rules apply only where designated by Timetable or Bulletin Order. ACSES will automatically apply the brakes of an equipped train if the engineer fails to take proper action to comply with a permanent or temporary speed restriction, or an interlocking or controlled point (CP) signal displaying Stop Signal.

Positive Train Stop (PTS) Zone: The PTS Zone is the length of track preceding interlocking signals and controlled point signals, within which the ACSES calculated PTS braking curve will force a train to stop before reaching a Stop Signal, by causing a penalty brake application. The PTS Zone extends approximately 1000 feet from the interlocking or CP signal, varying in length depending upon the distance between the distant signal and the interlocking or CP signal, and rail adhesion conditions.

580. Trains Equipped with ACSES Apparatus

All trains operating in ACSES territory must be equipped with ACSES apparatus, unless otherwise authorized by Special Instruction. (See SI 580-S2, page 344)

581. Testing the ACSES Apparatus

a. Departure Test

The ACSES apparatus on the leading end of the first engine or control car of each equipped train must be tested and found to be operational within 24 hours before the engine or control car leaves its initial terminal. If test equipment is not available at a point where another unit will be required to become a lead unit, this unit must also be tested at the initial terminal.

580-S1. (Cont'd)

581. (Cont'd)

The employee performing the test must post a signed copy of the test results in the cab of the locomotive and must leave a signed copy of the test results at the test location.

b. Engineer's Responsibility

Engineers taking charge of an equipped engine destined for ACSES territory must examine the test form to ensure that the on-board apparatus has been tested within the prescribed period, and must examine the ACSES display to ensure that the apparatus is cut in. The Missing Transponder Symbol (“--”) will be displayed on the track speed indicator until the engine enters ACSES territory.

If the engine is equipped with a train-type selector switch, the Engineer must ensure that the switch is in the correct position, as determined by the train's consist and the train type definitions that are included in the timetable.

c. Operating from Equipped Unit Without Departure Test

If necessary en route to operate from an equipped unit or end that had not been given a departure test, the ACSES apparatus must be considered inoperative. Rule 584, “Movement With Inoperative On-board ACSES Apparatus,” must be observed.

d. ACSES Failure on Equipment in Turnaround Service

Under the following conditions, a train that has experienced an ACSES failure may be dispatched from a turnaround point, governed by the rules that apply to an en route failure (Rule 584):

1. The equipment is used in turnaround service between its originating terminal and the turnaround point,

AND

2. The equipment received a satisfactory ACSES test within the previous 24 hours,

AND

3. No mechanical forces are on duty at the turnaround point to repair the equipment.

The crew must advise the Dispatcher of the failure before leaving the turnaround point. The equipment must be repaired or replaced at the next forward point that will not cause undue delay to the train.

582. ACSES Display and Enforcement of Track Speeds

a. ACSES Conforms to Known Track Speeds

1. The on-board ACSES apparatus will display and enforce all permanent and temporary track speed limits. When approaching a location where the track speed is more restrictive, the track speed indicator will display the speed change prior to reaching the restriction if a reduction in speed is required.

Exception: Temporary Transponders - Where temporary transponders are used to enforce temporary speed restrictions:

- i. Temporary speed restrictions will be displayed and enforced as soon as the engine passes the temporary transponder, regardless of the train's speed.
- ii. Temporary transponders will be installed at the location of the *Approach Speed Limit Sign* to ensure adequate braking distance.
- iii. ACSES will not display or enforce temporary speed restrictions within interlocking limits.

2. When the track speed indicator changes to a more restrictive speed, the audible indicator will sound until the speed change is acknowledged. Failure to acknowledge the change within 8 seconds or to satisfy the required braking rate will result in a penalty application of the brakes.

580-S1. (Cont'd)

582. (Cont'd)

3. When the track speed indicator changes to a more favorable speed, the audible indicator will transmit a short sound, which will not require acknowledgment. Speed must not be increased until the entire train has cleared previous lower speed limit.

4. Where ACSES data radio is in service and a train is diverted at an interlocking over one or more switches, ACSES will display and enforce the speed of the slowest crossover in the established route on trains that are equipped with the "ACSES II T.S.R. Data Radio" version of on-board apparatus. This crossover speed enforcement will continue until the head end of the train clears the interlocking, but may release sooner at certain locations.

b. ACSES Does Not Conform to Known Track Speeds: More Restrictive Speed Governs

1. If ACSES displays an incorrect speed limit, the lower speed limit will apply.

2. If ACSES displays the Missing Transponder Symbol ("--"), the train will operate according to track and signal speed limits, not exceeding 110 MPH between New Haven and Boston, and 125 MPH between New York and Washington.

3. If ACSES displays the **Missing Temporary Speed Symbol** (display alternates between "--" and permanent track speed, the train will operate according to track and signal speed limits. Although ACSES will cap the maximum speed displayed at 125 MPH in all ACSES equipped territory, trains operating between New Haven and Boston must not exceed 110 MPH.

4. When approaching an interlocking, if data radio reception is interrupted and train routing data is not received by the on-board ACSES apparatus, ACSES may enforce a temporary speed restriction that exists on an adjacent track within or beyond the interlocking, as a precaution in case the train is routed to the affected track. This adjacent track temporary speed restriction enforcement will be released when the train exits the interlocking.

5. On High Speed Trainsets, various internal faults (e.g., "ACSES Data Not Available") may cause the display of Train Type "B" speeds instead of Train Type "A" speeds, even when the tilt system is still functional. When this occurs, a report must be made to the Dispatcher, and the train will be governed by the Train Type "B" speeds displayed. This type of malfunction will not be considered an ACSES failure, but must be recorded on MAP 100.

c. If one of the conditions listed in Part "b" occurs:

1. The Engineer must notify the Dispatcher as soon as possible without delay to the train. The report must include the location and description of the non-conformity.

Exception: Non-conformities referenced in Rule 586, "Circumstances in Which ACSES May Not Indicate Current Wayside Conditions," need not be reported to the Dispatcher.

2. The Dispatcher must relay all reported information to appropriate Mechanical and C&S personnel, so that they can investigate the non-conformity.

3. Normal speed may be resumed once ACSES displays a correct speed on the track speed indicator, unless an ACSES on-board apparatus failure has occurred as described in Rule 584(a).

583. ACSES Enforcement of Interlocking and CP Signals

a. Stop Signal Enforcement

ACSES will enforce a positive stop at interlocking and CP signals displaying Stop Signal.

b. Approaching Interlocking & CP Signals

ACSES will cause a penalty application of the brakes to occur on trains that are approaching interlocking and CP signals, if:

580-S1. (Cont'd)

583. (Cont'd)

1. The train is approaching the signal at a speed above the braking curve for the signal, as calculated by the on-board ACSES apparatus. (On engines equipped to do so, Stop Signal will be displayed on the cab signal aspect when the penalty application occurs.)

or

2. The train stops within the PTS Zone with a Restricting cab signal or with cab signals cut out, and the brakes are released while the interlocking or CP signal displays Stop Signal.

or

3. Where either wayside or on-board data radio is inoperative, the train stops within the PTS Zone with a Restricting cab signal or with cab signals cut out, and the brakes are released before the Stop Release Button is pressed.

c. **Positive Stop Enforced Within the PTS Zone:**

Once stopped by ACSES within the PTS Zone, trains must not resume movement toward a Stop Signal.

NOTE: At higher approach speeds, a penalty brake application may force the train to stop prior to reaching the PTS Zone. If this occurs, the brakes may be released without operating the Stop Release Button.

d. **Stop Release Button**

Unauthorized use of the Stop Release Button may interfere with the safe passage of trains, and is therefore prohibited. Unless otherwise specified, use of the Stop Release Button is authorized only as prescribed below:

1. **Train at Stop Signal - Rule 241 Permission:**

After a train has received Rule 241 permission from the Dispatcher to pass a fixed signal displaying Stop Signal, and the Dispatcher or Operator has confirmed the repetition of that permission, the Stop Release Button may be operated to allow the train to proceed.

2. **Train Shoving Past Home Signal:**

When a home signal displaying an aspect more favorable than Stop Signal is displayed for a train that is being operated from other than the leading end, a penalty brake application may occur when the leading end of the movement operates past the home signal. Should a penalty brake application occur under these circumstances, the Stop Release Button must not be used until the crew has received the Dispatcher's permission as prescribed in Section 4 of this rule, "**Train at Signal Other Than Stop Signal**".

3. **Train Making Station Stop Near Stop Signal**

When making a station stop near an interlocking signal displaying Stop Signal, the location of the positive stop enforced by ACSES may be short of the desired station stop location. If this occurs, the Engineer must contact the Dispatcher to ask whether the interlocking signal can be displayed. If immediate display of the signal is not possible due to prevailing conditions, the Stop Release Button must not be used, and the train's brakes must remain applied until the signal displays an aspect more favorable than Stop Signal.

4. **Train at Signal Other Than Stop Signal:**

It should not be necessary to use the Stop Release Button to pass any fixed signal **other than** a Stop Signal at any data radio equipped interlocking or Controlled Point, except when an ACSES data radio failure has occurred. The Stop Release Button must not be used until the crew has received the Dispatcher's permission as prescribed below:

580-S1. (Cont'd)

583. (Cont'd)

- (a) The crew must advise the Dispatcher of the train's location, track, direction, and the name of the next governing signal.
- (b) Before granting permission to use the Stop Release Button to pass a fixed signal other than Stop Signal, the Dispatcher must verify the train's location, track, direction and route status, and ensure that no opposing or conflicting movements have been authorized.
- (c) Once it has been determined that it is safe to do so, permission to use the Stop Release Button to pass a fixed signal other than Stop Signal must be given in the following manner:
"No. 314 engine 4129 may use the ACSES Stop Release Button on No. 2 track at Rare."
The receiving employee must repeat this permission to the Dispatcher or Operator, and must not use the Stop Release Button until the Dispatcher or Operator has confirmed the repetition.
- (d) The Dispatcher or Operator must record and report all information pertaining to the ACSES anomaly.

5. Movement Restriction After Stop Release Button is Pressed:

Once permission has been received and the Stop Release Button has been pressed, ACSES will display and enforce a track speed of 15 MPH until the engine clears the interlocking or CP.

584. Movement With Inoperative On-board ACSES Apparatus

The movement of a train equipped with inoperative on-board ACSES apparatus is prohibited, except when failure occurs after the engine leaves its initial terminal.

a. Criteria for Determining ACSES On-board Apparatus Failure

The ACSES on-board apparatus will be considered as having failed if any of the following conditions occur:

1. The audible indicator fails to sound when the ACSES display changes to a more restrictive speed.
2. The audible indicator continues to sound even though the ACSES change was acknowledged and the speed of the train was reduced to the speed required by ACSES.
3. The track speed indicator fails to conform to 3 permanent speed changes in succession.
4. Damage or fault occurs to any part of the ACSES on-board apparatus.

Note: Display of the **Missing Temporary Speed Symbol** (display alternates between "– –" and permanent track speed) is not an ACSES on-board apparatus failure. However, the train must operate according to track and signal speed limits, not exceeding 110 MPH on the NHB Line* and 125 MPH on the NYP & PW Lines. The Engineer must notify the Dispatcher as soon as possible without delay to the train, regarding the location and description of the non-conformity.

b. Engineer's Responsibility

If the on-board ACSES apparatus fails en route, the Engineer must take the following actions:

1. Cut out the on-board ACSES apparatus.
2. Operate according to track and signal speed limits, not exceeding 110 MPH between New Haven and Boston, and 125 MPH between New York and Washington.

580-S1. (Cont'd)

584. (Cont'd)

3. Notify the Dispatcher and Conductor as soon as possible without delay to the train. The reason and location of the failure must be included in this report.
4. Consider the failed on-board ACSES apparatus as inoperative until the apparatus has been repaired, tested and found to be functioning properly.

c. Dispatcher's Responsibility

Dispatchers who are notified of an on-board ACSES apparatus failure must take the following actions:

1. Promptly notify appropriate Mechanical and Signal personnel of the reason and location of the failure.
2. Promptly notify the Dispatcher of the connecting dispatching district.

585. ACSES Operation with Failed Cab Signals

ACSES will function differently on trains with the on-board cab signal apparatus cut out because of an en route cab signal failure:

1. The Missing Transponder Symbol (“-”) will be displayed continuously.
2. ACSES will continue to enforce track speed limits, and interlocking and CP signals displaying Stop Signal.
3. ACSES will enforce Slow Speed, Medium Speed and Limited Speed routes within interlocking limits.
4. ACSES will enforce a positive stop at interlocking or CP signals governing entrance to Rule 562 territory, when Clear to Next Interlocking Signal is not displayed.

Trains will be governed by the rules that apply to cab signal failures.

Note: In ACSES territory where data radios are **not** in service, trains operating with failed cab signals, or where DCS rules have been substituted for ABS rules, must cut out the on-board ACSES apparatus.

586. Circumstances in Which ACSES May Not Indicate Current Wayside Conditions

ACSES may not indicate current wayside conditions under the following circumstances:

1. When a train enters ACSES territory at a hand-operated switch or makes a reverse move in ACSES territory, ACSES may not display the correct track speed until the engine passes the first transponder set.
2. When a train makes a diverting move through an interlocking, ACSES may not display the correct speed of the track to which the train is routed until the train passes the first transponder set on the affected track.
3. When an engine passes a transponder while moving at less than 3 MPH, ACSES may display the Missing Transponder Symbol.
4. When entering an area where multiple closely spaced civil or temporary speeds are encountered in succession, ACSES will enforce each civil speed and speed restriction, but may not display all intermediate speed changes.

587. Movements that Must Not Exceed 20 MPH

Trains that enter ACSES territory at a hand-operated switch or make a reverse move between transponder sets must not exceed 20 MPH until a valid track speed is displayed on the track speed indicator.

580-S1. (Cont'd)

588. Wayside Portion of ACSES Not Operative

If the wayside portion of ACSES is inoperative, the Dispatcher may issue a Form D line 13 or verbal instructions to temporarily suspend ACSES Rules in the area affected by the malfunction. The Signal Department may install temporary transponders to automatically suspend operation of the on-board ACSES apparatus within the designated limits. The Engineer must NOT manually cut out the on-board apparatus.

Movement within the designated limits will operate according to track and signal speed limits, not exceeding 110 MPH between New Haven and Boston, and 125 MPH between New York and Washington.

589. Reliance on ACSES

ACSES enforcement of track speeds and signal indications does not relieve employees from their responsibility for maintaining thorough knowledge of physical characteristics and track speeds. ACSES is intended to supplement, not replace, employee knowledge and skills.

590. Dispatcher's Responsibility for Recording Movements

Dispatchers must record on the Record of Train Movements the movement of trains operating under any of the following conditions:

1. ACSES does not conform to track speeds.
2. Movement with inoperative on-board ACSES apparatus.
3. Wayside portion of ACSES inoperative.

591. Engineer's Responsibility to Report on Forms

Engineers must report the following occurrences on the prescribed form, in addition to verbally reporting them as prescribed by previous rules:

1. ACSES does not conform to track speeds.
2. Movement with inoperative on-board ACSES apparatus.

580-S2. TRAINS EQUIPPED WITH ACSES APPARATUS

On the Main Line–New Haven to Boston (NHB), all trains must be equipped with operative on-board ACSES apparatus. On the Main Line–New York to Philadelphia (NYP), Main Line–Philadelphia to Washington (PW), and Main Line–Harold to CP 216 (NYS), all Amtrak trains must be equipped with operative on-board ACSES apparatus. Trains must not be dispatched from their initial terminal with failed on-board ACSES data radio apparatus.

1. MARC HHP-8 Locomotives: When used to haul Amtrak trains, the ACSES apparatus on MARC HHP-8 locomotives must be cut in and operative.

2. Exempt Amtrak Engines: On the NYS, PW & NYP Lines, the following Amtrak engines are exempt from the above ACSES requirements: Model P-42BH engine Nos. 1–100 & 112–207; Model P32 engine Nos. 512, 513 & 514; Model SW1001 engine No. 569; Model GP38 engine No. 724; Model P-40BH engine Nos. 800–823, 825–836 & 838–841.

581-S1. ACSES DEPARTURE TEST: MAP 100

When taking charge of an ACSES equipped engine destined for ACSES territory, engine service employees must examine the MAP 100 form to determine that the on-board ACSES apparatus has been tested within the prescribed period. If necessary, the Engineer will perform a self-test, then note the time and date of the test, and his signature, on the locomotive inspection form. Engineers must promptly advise the Dispatcher whenever it is necessary for them to perform an ACSES test, and the result of the test.

581-S2. ACSES TRAIN TYPE SELECTOR SWITCH

When taking charge of a train that is destined for ACSES territory, the Engineer must ensure that the ACSES train type setting on the controlling engine corresponds with the train's consist, as follows. See also 37-B1, 37-N1, 37-P1, or 37-G1.

- **Train Type A** - High Speed Trainsets (HST) with tilt system active.
- **Train Type B** - (1) HST's with tilt system disabled; and (2) trains consisting exclusively of HHP-8, AEM-7, ACS-64, P40BH, P42BH, P32AC-DM, or P32-BWH engines, and Amfleet, Horizon, Capitoliner Control/ Conference Cars, LDSL Baggage Cars 61000-61084, MARC III control/coach cars, or US DOT test car DOTX 216.
- **Train Type C** - Passenger trains that do not meet the criteria for train types A, B, or D.
- **Train Type D** - Passenger trains with mail, baggage or express cars in consist, that meet the Train Type D criteria defined in SI 37-S8.

The ACSES train type that is active is indicated by a flashing light next to the train type letter (B, C, D or E) on the ACSES train type selection panel, not by the position of the train type selector knob.

If the active train type does not conform to the train's consist, the Engineer must change it by moving the train type selector knob to the correct position, and then initiating an ACSES self test. When the self test has completed, the Engineer must check the ACSES train type selection panel to ensure that the correct train type has been activated, then note the time and date of the test, and his signature, on the locomotive inspection form. The same process must be followed if the train's consist is changed enroute, resulting in the train qualifying for a different train type.

Train Consist Notes:

(1) High Speed Trainsets (HST's): The above requirements do not apply to HST's, which are automatically set to Train Type "A" or "B" depending on whether the tilt system is active ("A") or disabled ("B").

(2) Commuter Agency or Freight Carrier Engines: The above requirements do not apply to commuter agency or freight carrier engines that do not have a train type selector switch. These units are set internally to Train Type "C" or "E", respectively.

(3) MARC III Control/Coach Cars are Train Type "B" between Washington and New York (PW & NYP Lines), but are Train Type "C" between New Haven and Boston (NHB Line). Trains with this equipment in consist that will be operating through New York must change the active train type while stopped in New Haven or New York, so that it will conform to the territory to which they are destined.

581-S3. ACSES ACTIVATION IN NON-ACSES TERRITORY

If ACSES displays anything other than the Missing Transponder Symbol in territory where ACSES is not in effect, or if it should become necessary to reset the locomotive after entering such territory, the ACSES Electric Cut Out Switch located on the side of the ACSES equipment box must be placed in the “OUT” position. Once ACSES has been electrically cut out in this manner, ACS-64s, HST's and HHP-8's will display “ACSES Cut Out” in the alarm box of the MFD1/TOD screen. On other ACSES equipped engines, the red “Track Speed Cut Out” light will illuminate. Prior to entering ACSES equipped territory, ACSES must be cut back in without delay to the train. Re-testing the on-board ACSES apparatus is **not** required when the system is cut out and cut in electrically, as described above.

582-S1. ACSES DISPLAY AND ENFORCEMENT OF TRACK SPEEDS

In the application of ACSES Rule 582, the track speed indicator on certain engines may be capped at the maximum speed of the engine, or a speed 5 MPH above the maximum authorized speed of the engine.

582-S2. ACSES TEMPORARY TRANSPONDER PLACEMENT

Temporary transponders used to enforce temporary speed restrictions are placed at approximately the same locations as temporary speed signs. Before placing or removing temporary transponders on an in-service track, Engineering Department employees must contact the Dispatcher to determine the established direction of traffic on the track segment involved, and to obtain a hold against movements in the opposite direction. Temporary transponders must then be placed in sequential order, starting with the transponder set that would be the last one encountered by trains operating in the established direction of traffic. Temporary transponders must be removed in sequential order, starting with the transponder set that would be the first one encountered by trains operating with the established direction of traffic.

Before providing established direction of traffic information and assurance of a hold in the opposite direction, the Dispatcher must apply blocking devices to prevent the operation of trains in the opposite direction. These blocking devices must remain applied until notified that all temporary transponders are in place. If foul time is requested because of inadequate watchman/lookout protection, a hold must be placed on approaching trains in either direction.

584-S1. FAILURE OF ACSES ON-BOARD APPARATUS TO RELEASE TEMPORARY SPEED RESTRICTION

If the on-board ACSES apparatus fails to release a temporary speed restriction after passing the Approach Speed Limit Sign for trains approaching the restriction in the opposite direction, the Engineer must reset the ACSES system by stopping the train, placing the automatic brake valve in “Suppression”, opening the ACSES circuit breaker **for 30 seconds**, and then closing the circuit breaker. If opening the circuit breaker fails to clear the restriction, the on-board ACSES apparatus must be cut out, and Rule 584 will apply.

586-S1. BACK-UP MOVES IN ACSES TERRITORY

When a train is backing up or pushing cars in ACSES territory, ACSES may not enforce a positive stop at interlocking or controlled point signals.

INTERLOCKING RULES

600-S1. INTERLOCKING RULES

Where Interlocking Rules are in effect between the interlockings and it is necessary to issue verbal permission to pass a signal in stop position for movement between these interlockings, the Operator or Dispatcher must confer with the Operator or Dispatcher who controls opposing movements to insure that opposing signals are in stop position.

601-S1. LOCAL CONTROL OF INTERLOCKINGS BY C&S EMPLOYEES

A. General Requirements

A C&S employee may only request permission to take local control of an interlocking to:

- ▶ Assist the Dispatcher when remote control is lost, or
- ▶ Expedite C&S switch, signal or track circuit inspection, testing, troubleshooting, adjustments, and general maintenance, or
- ▶ Expedite joint C&S and MW switch inspections, testing or maintenance.

C&S employees must obtain permission from the Dispatcher before taking local control, and must follow the Dispatcher's instructions while the interlocking is in local control, including the application and removal of blocking devices.

The Dispatcher must not authorize local control when a track within interlocking limits is out of service by Form D line 4, except as outlined in section "B" below.

1. Qualification Requirements for C&S Employees:

C&S employees who take local control must be qualified on the operating rules, all operating functions of the local control panel, and the physical characteristics of the interlocking.

2. Job Briefings with the Dispatcher

Before permission to take local control is given or received, the C&S employee and the Dispatcher must have a job briefing to discuss:

- a) The identification and reason for any blocking devices applied by the Dispatcher. (See section 3 below.)
- b) The nature of any C&S, or joint C&S and MW, tests or inspections to be performed, and the effect that the work will have on the Dispatcher's model board indications.
- c) Whether testing or inspection activities will require the use of opposing Stop Signals to establish exclusive track occupancy protection.

The C&S employee granted local control must conduct an additional job briefing with the Dispatcher each time the conditions of the work change.

3. Blocking Devices Applied or Ordered Applied by the Dispatcher

- a) Dispatcher instructions regarding the application or removal of blocking devices must be correctly repeated by the C&S employee receiving them, before being acted upon.
- b) C&S employees must obtain permission from the Dispatcher before removing any blocking devices applied by, or ordered applied by, the Dispatcher.
- c) C&S employees must keep a written record of these blocking devices on form **NRPC 3436** to ensure compliance. The record must include the identification of each blocking device, the time it was applied, and the time the Dispatcher authorized its removal.
- d) Once control of the interlocking is returned to the Dispatcher, the C&S employee must draw an "X" through the blocking device record, and retain the record for 7 days. (See section D below.)

(601-S1 Cont'd)

4. Permission to Take Local Control

- a) The Dispatcher's permission to take local control must include the title and name of the employee authorized to take local control, the interlocking name, and the time permission is being given.
- b) The receiving employee must document the permission on form **NRPC 3436** and repeat it to the Dispatcher or Operator, who must then confirm it before the receiving employee takes local control.

5. Displaying Signals for Train Movements

The C&S employee must not display a signal for a train movement unless:

- a) Authorized by the Dispatcher.
- b) The C&S employee and the Dispatcher have discussed and verified the position of all switches involved in the route.
- c) All affected Roadway Workers are clear of the tracks to be used, or have established alternate protection.

6. Permission by Stop Signals

While an interlocking is in local control, Dispatchers must not issue Rule 241 permission for a train to pass a Stop Signal until they have contacted the C&S employee in control of the interlocking to confirm the position of all switches involved in the route, and to advise the C&S employee of the move to be made.

B. Track Out-of-Service within Interlocking Limits by Form D Line 4

1. Dispatcher Responsibility

The Dispatcher must not authorize local control when a track within interlocking limits is out of service by Form D line 4, except:

- a) In an emergency,
- b) When necessary to route a train to, from or around an out of service track on which a track circuit has been de-energized, or
- c) When necessary to perform C&S tests on a movable bridge.

2. C&S Responsibility

The C&S employee authorized to take local control must receive permission from the person in charge of the out-of-service track and be read or shown a copy of the Form D before operating any interlocking appliance on that track.

C. Roadway Worker Protection

1. Restrictions

The C&S employee must not authorize:

- a) Any work unrelated to C&S testing or inspection, or joint C&S and MW switch inspections.
- b) Any work that involves on-track equipment or will disturb the track or catenary structure so that it would be unsafe for Normal Speed.

NOTE: When protection outside of interlocking limits is required, Foul Time must be obtained from the Dispatcher in the usual manner. Before granting Foul Time, the Dispatcher must order the C&S employee who has local control of any affected interlockings to apply blocking devices to the affected controls.

2. Exclusive Track Occupancy Using Opposing Stop Signals

In the application of Amtrak and Federal Roadway Worker Protection rules, a qualified C&S employee who has local control of an interlocking may, with permission of the Dispatcher, use opposing Stop Signals to establish exclusive track occupancy protection for employees involved with the C&S testing or inspection being conducted, or joint C&S and MW switch inspections.

(601-S1 Cont'd)

The C&S employee must:

- a) Prior to establishing working limits, apply blocking devices to prevent the display of any signal leading to the limits to be protected.
- b) Keep a written record of these blocking devices on form **NRPC 3436** to ensure compliance. The record must include the identification of each blocking device, the time it was applied, and the time removed. It is not necessary to report these blocking devices to the Dispatcher.
- c) Blocking devices must remain applied until all employees authorized to foul the track have cleared the affected track(s), or the employees have established alternate protection.

D. Returning Remote Control to the Dispatcher

Before returning remote control to the Dispatcher, the C&S employee in charge must:

1. Notify all affected Roadway Workers that remote control is being returned to the Dispatcher for the operation of trains.
2. Ensure that all affected Roadway Workers are clear of the tracks or have established alternate protection.
3. Notify the Dispatcher that all Roadway Workers are clear or have established alternate protection, and that control of the interlocking is being returned.

Once control of the interlocking is returned to the Dispatcher, the C&S employee must document the time on form **NRPC 3436** and retain the record for 7 days.

605-S1. SEPTA RAIL CLEANING CARS

Septa Rail Cleaning Cars RC-1 and RC-2 are converted rail grinding cars that have been equipped with wire brushes to scrape leaf residue off the rail. They may be pushed or pulled by an engine over the NEC, subject to the following restrictions:

- (1) They may be operated at speeds up to 25 MPH, not exceeding the maximum speeds for freight trains.
- (2) They must not be coupled to other types of equipment, other than the engine that is pushing or pulling them.
- (3) While operating within interlocking limits, they must receive following movement and route protection in accordance with Rule 605, "Movements That Might Not Shunt."
- (4) While operating in ABS territory, they must receive following movement protection in accordance with Rule 506, "Trains that Might Not Shunt."

RADIOS, TELEPHONES, AND ELECTRONIC DEVICES

701-S1. COMMUNICATION REQUIREMENTS FOR TRAINS

Trains must not be dispatched from their initial terminal without a working locomotive radio on the leading end of the controlling engine. Trains must also be equipped with a backup means for communicating with the Dispatcher. The backup means shall be a second locomotive radio or a portable radio capable of reaching the Dispatcher.

Employees must test each required means of communication as soon as practicable, prior to the commencement of their work assignment. If the device fails to function as intended, the Dispatcher must be notified as soon as practicable.

If the locomotive radio on the controlling engine fails en route, a portable radio must be placed on the controlling engine at the next location where portable radios are available. If a required backup means of communication fails en route, the device must

701-S1. (Cont'd)

be repaired or replaced at the next location where it is possible to do so.

For the purpose of this instruction, an initial terminal is defined as the location where the locomotive receives its calendar day inspection, and any subsequent turning point where mechanical forces are on duty who can repair or replace a defective locomotive radio. If it is not possible to repair or replace a defective locomotive radio at a turning point without undue delay to the train, the train may be dispatched from the turning point with a portable radio on the head end, and a crew member stationed at a working locomotive radio at another location in the train.

701-S2. RADIO COMMUNICATION WITH ENGINEERS

Employees should avoid using Engineers to relay or provide routine, non-emergency information that does not directly affect the train's movement. Whenever possible, such communication must be made directly with the other parties involved. For example, a Conductor needing a wheel chair at an upcoming station should use his or her railroad-supplied cell phone or radio to communicate directly with Customer Services personnel, and a Dispatcher needing information on a train delay should obtain the information directly from the Conductor.

706-S1. DISPATCHER RADIO CHANNEL TERRITORIES

All Dispatcher offices are equipped with road radios, channel 054-054. **Exceptions:**
Boston—Westbound and southbound trains must change to radio channel 029-029 at Division Post (MP 72.9). Radio Channel 092-092 in service on the Dorchester Branch and all Old Colony lines. Trains must switch to channel 092-092 when operating between Hill and Fort Point Channel UG Bridge, MP 227.9.

New York—PSCC also equipped with LIRR channel 2. Dispatchers Office and Terminal Operations Center also equipped with road radio channel 060-060.

Philadelphia—Section C Dispatcher also equipped with road radio channel 035-035.

706-S2. NARROW BAND RADIO CHANNELS

All Amtrak radios must be operated only on narrow band channels, displaying a "0" before the channel number i.e., 023-023, 054-054, or NEC RD 054.

Exception: Narrowband compliant Locomotive, Power Car, Cab Car, and NPCU radios are indicated by a serial number on the face of the radio containing the letter 'D', and may display two digit channel numbers.

714-S1. TELEPHONE NUMBERS—DISPATCHERS, OPERATORS, ETC.

Dispatcher/Operator	Exchange	ATS	Commercial
NHB, DB, MRS, & MM LINES			
Chief Dspr	Boston	580-7569, 7570	617-345-7569, 7570
Form D inquiry only	Boston	580-7585	617-345-7585
Terminal TD	Boston	580-7565	617-345-7565
Corridor TD	Boston	580-7561	617-345-7561
Main Line TD	Boston	580-7562	617-345-7562
New London TD	Boston	580-7567	617-345-7567
South County TD	Boston	580-7580	617-345-7580
Dorchester TD	Boston	580-7492	617-345-7492
Shore Line TD	Boston	580-7568	617-345-7568
Springfield Line TD	Boston	580-7574	617-345-7574
Power Director	Boston	580-7714	617-345-7714

714-S1. (Cont'd)			
Dispatcher/Operator	Exchange	ATS	Commercial
NHB, DB, MRS, & MM LINES (Cont'd)			
Conn	New London	568-5622	860-510-5622
Mystic River	New London	566-3908	860-446-3908
Nan	New London	568-5628	860-510-5628
NYS, HUD, PRB, NGB, NYT & NYP LINES			
Chief Dspr	Penn Sta.	521-7467	212-630-7467
Power Director - Zone 1 (Shell to Bergen)	Penn Sta.	521-7684	212-630-7684
Power Director - Zone 2 & 3 (Bergen to MP 76)	Penn Sta.	521-7680	212-630-7680
.....	Penn Sta.	521-7682	212-630-7682
Power Supvr (MNR Dspr)	G. C. T.	...	212-340-2100
Penn Station Central Control	Penn Sta.	521-6308	212-630-6308
.....	Penn Sta.	521-6309	212-630-6309
.....	Penn Sta.	521-6286	212-630-6286
Terminal Oprs Cntr	Penn Sta.	521-6466	212-630-6466
Dspr. Sec. A	Penn Sta.	521-7472	212-630-7472
Dspr. Sec. B	Penn Sta.	521-7471	212-630-7471
CETC-9 TD	Penn Sta.	521-6881	212-630-6881
CETC-8 TD	Penn Sta.	521-6409	212-630-6409
CETC-7 TD	Penn Sta.	521-6408	212-630-6408
Hudson Line TD	Penn Sta.	521-7370	212-630-7370
Hudson North TD	Penn Sta.	521-6788	212-630-6788
LAB	Albany	518-465-0746
Pelham Bay	Penn Sta.	521-7193	212-630-7193
Q	Penn Sta.	521-7763	212-630-7763
R	Penn Sta.	521-7349	212-630-7349
Dock	Newark	525-2377	973-596-2377
Union	Newark	525-2382	973-596-2382
WT, PW, NYP, 36SC & PH LINES			
Chief Dspr	Phila.	728-2417	215-349-2417
Asst Chief H	Phila.	728-2226	215-349-2226
.....	Phila.	728-2227	215-349-2227
Dspr. Sec. B	Phila.	728-2230	215-349-2230
Dspr. Sec. C	Phila.	728-2231	215-349-2231
Asst Chief I	Phila.	728-2251	215-349-2251
.....	Phila.	728-2252	215-349-2252
CETC-1 TD	Phila.	728-2263	215-349-2263
CETC-2 TD	Phila.	728-2264	215-349-2264
CETC-3 TD	Phila.	728-2265	215-349-2265
CETC-4 TD	Phila.	728-2266	215-349-2266
CETC-5 TD	Phila.	728-2233	215-349-2233
CETC-6 TD	Phila.	728-2232	215-349-2232

714-S1. (Cont'd)			
Dispatcher/Operator	Exchange	ATS	Commercial
WT, PW, NYP, 36SC & PH LINES (Cont'd)			
Power Director - Zone 4 (MP 76 [Holmes]- Glenolden) (Zoo-MP 21.3 [Paoli])	Phila.	728-2276	215-349-2276
Power Director - Zone 5 (Glenolden-Gunpow)	Phila.	728-2277	215-349-2277
Power Director - Zone 6 (Gunpow to Washington Terminal)	Phila.	728-2257	215-349-2257
Power Director - Zones 8 & 9 (MP 21.3[Paoli]- Harrisburg)	Phila. Phila.	728-1038 728-1048	215-349-1038 215-349-1048
DAC Clerk	Phila.	728-2234	215-349-2234
Psgr. Clerk-North	Phila.	728-2235	215-349-2235
Psgr. Clerk-South	Phila.	728-2394	215-349-2394
Overbrook	Phila.	728-2335	215-349-2335
Paoli	Phila.	728-2336	215-349-2336
State	Hrbg.	724-3336	717-232-3336
Thorn	Lanc.	738-5043	717-291-5043
.	Phila.	728-3237	215-349-3237
Zoo	Phila.	728-2340	215-349-2340
Control Center Toll Free	Wash.	777-2301	202-906-2301 800-372-9700
Crew Dspr. Toll Free	Wash.	777-2319	202-906-2319 800-372-9600
K Tower	Wash.	777-2323	202-906-2323
Yardmaster	Wash.	777-2328	202-906-2328

714-S2. TELEPHONE NUMBERS-AMTRAK POLICE

LOCATION	TELEPHONE NUMBER
BOSTON — NEW HAVEN	
1 Frontage Road, Boston, MA	617-345-7801 ATS:580-7801
Union Station, Providence, RI	401-727-7373 ATS:575-7373
Union Station, 50 Union Avenue, New Haven, CT	203-773-6000 ATS:561-6000
NEW YORK — TRENTON	
Penna. Station, New York, NY	212-630-7112 ATS:521-7112
Newark Station, Newark, NJ	201-596-2344 ATS:525-2344
Trenton Psgr. Station, Trenton, NJ	609-989-1773 ATS:742-1773

714-S2. (Cont'd)	
LOCATION	TELEPHONE NUMBER
PHILADELPHIA — WASHINGTON	
30th St. Station, Phila. PA	215-349-3333 ATS:728-3333
Harrisburg Sta., Harrisburg, PA	717-232-3333 ATS:724-3333
Wilmington Shops, Wilmington, DE	302-429-6511 ATS:739-6511
Baltimore Sta., Baltimore, MD	410-291-4230 ATS:729-4230
Washington, D.C.	202-906-3263 ATS:777-3263
ALL LOCATIONS: 1-800-331-0008	

714-S3. TELEPHONE NUMBERS-CREW DISPATCHERS

Crew Base	Type of Call	Telephone Number
All	T&E Employee Payroll Hotline	888-818-2024
All	Assignments Department	877-850-2260
All	To call crew dispatcher from a non-Amtrak location	800-828-2739
Boston Springfield New Haven	Train and Engine employees in road passenger service reporting to duty with crew dispatcher at sign up location.	8-734-2131
New York	Train and Engine employees in road passenger service reporting to duty with crew dispatcher at sign up location.	Zone 1: 8-734-2131
		Zone 2: 8-734-2132
Philadelphia and Harrisburg	Train and Engine employees in road passenger service reporting to duty with crew dispatcher at sign up location	8-734-2133
Washington	Train and Engine employees in road passenger service reporting to duty with crew dispatcher at sign-up location.	8-734-2134

NOTE 1: Calls on 800-828-2739 made from touch tone phones will receive a “prompt” requesting that the caller press the 4 digit number of the dispatching desk he wants to contact, i.e. Desk 1-2131, Desk 2-2132, Desk 3-2133, Desk 4-2134. Calls made from rotary or non-touch tone phones will go to a default line and be answered by the next available crew dispatcher.

NOTE 2: Recorders in service at Wilmington CNOG Central Crew Dispatcher's headquarters. All incoming and outgoing calls will be recorded.

716-S1. USE OF PERSONAL ELECTRONIC DEVICES: RESTRICTIONS

In the application of Rule 716, a personal electronic device must not be used when a railroad radio or a railroad-supplied electronic device is available.

716-S2. USE OF TELEPHONES FOR EMPLOYEES INVOLVED IN MAIN TRACK AUTHORITIES AND MANDATORY DIRECTIVES

Telephones must **not** be used in lieu of radio communication to obtain or release main track authorities or to copy mandatory directives. Where radio communication is not possible, a telephone may be used to obtain or release main track authorities or to copy mandatory directives.

- a. Before using a telephone to obtain or release a main track authority or copy a mandatory directive, all crew members must participate in a job briefing and agree that it is safe to do so.
- b. Immediately after **obtaining** main track authorities or copying a mandatory directive, all crew members must again participate in a job briefing to properly disseminate information from that communication.
- c. Before **reporting clear or releasing** a main track authority, all crew members must participate in a job briefing to ascertain and agree on the exact location that their entire train has passed, and that it has cleared the affected limits (DTC Block, Track Warrant, Track Permit, etc.).

716-S3. USE OF ELECTRONIC DEVICES OR RAILROAD RADIOS WHILE OPERATING A COMPANY HIGHWAY VEHICLE

An electronic Device or Railroad Radio must not be used while operating company owned or leased vehicles, or personal vehicles for which the employee will be compensated for mileage costs.

- These devices must not be used to perform any function unless the vehicle is safely stopped.
- These devices must not be used while refueling railroad machinery/equipment/highway vehicle.

716-S4. PERSONAL EMERGENCY COMMUNICATIONS

When required to perform service, using a railroad-supplied device to receive a call, text or other message for other than for an "authorized business purpose" is considered to be use of a personal device, and is therefore prohibited.

To be contacted in the event of a personal emergency:

- T&E employees should instruct family members or emergency contacts to call CMS at 800-424-0217, Option 8.
- Non-T&E employees should provide family members or emergency contacts with the contact number for their appropriate supervisor.

716-S5. eTICKETING MOBILE DEVICE (eMD) - AUTHORIZED BUSINESS PURPOSES

Subject to the "Restrictions" contained in Rule 716, outlined below are the authorized business purposes of the railroad-supplied "eTicketing Mobile Device" (eMD) issued to Conductors and Assistant Conductors. Employees are prohibited from using an eMD for any purpose if that use would interfere with any employee's performance of safety related or customer service related duties.

The use of the eMD must be discussed during the crew's initial job briefing.

a) Revenue & Passenger Service Related Functions: eLift

- (1) Checking passenger on / off / on-board counts, including passenger details.
- (2) Scanning travel document barcodes (paper or electronic).
- (3) Using the magnetic stripe reader to log into the device and to record employee flash passes.
- (4) Searching for passenger tickets.
- (5) Editing a passenger's ticketed destination.
- (6) Recording tickets as lifted electronically, and deleting ticket lifts that were recorded in error.

716-S5. (Cont'd)

- (7) Adding passengers without electronic tickets to the manifest.
- (8) Reviewing on-board fares.
- (9) Performing passenger ID check functions.
- (10) Reviewing Sleeping Car accommodation diagrams and room occupancy data.
- (11) Using "Rescue Train" feature to download additional tickets.
- (12) Editing application settings, or using added functions authorized by Technical Advisory.

b) Revenue Calculations

The Calculator function may be used to perform basic arithmetic calculations, such as preparing on-board sales totals for remittance.

c) Mechanical Defect Troubleshooting & Reporting: eMap21a

Recording and reporting equipment issues that do not impede safe operations, but are required to maintain on-board service features (restroom cleanliness, seat fixtures etc.).

d) Delay Reporting

As outlined below, the eMD may be used for Electronic Delay Reporting (eDR), but only when this use will not interfere with any employee's safety related duties. Employees must be prepared to submit paper delay reports when required by system operating conditions or other instructions.

- (1) Establishing identity of employee responsible for reporting delays between specific reporting points, and denoting if initial terminal is not the scheduled initial terminal.
- (2) Entering actual arrival and departure times for reporting points as required.
- (3) Accounting for all lost time accrued during period of responsibility, providing appropriate delay reason codes and supporting information.

e) Voice and Text Communications

- (1) The voice and text functions of the eMD may only be used if such use will not interfere with any employee's performance of safety related duties.
- (2) Employees may use the eMD for voice communications only when radio communication has failed and such communications are directly related to the operation of their train or an emergency situation.
- (3) Employees may use the eMD for receiving text communications only when such communications are directly related to the operation of the railroad. Employees are prohibited from using the eMD to send text messages.
- (4) Employees should not interrupt the performance of customer service related duties to read text messages.

f) Time & Date Functions

- (1) Employees are required to carry a watch, set its time and use it as required by NORAC Rule 3, Correct Time.
- (2) Employees must not use the time date displayed on their eMD for railroad timekeeping purposes.
- (3) Future dates and days of the week may be determined using the Calendar function.

g) Device Software Updates & Troubleshooting: MobileIron

- (1) Installation of updates to authorized applications and configuration profiles.
- (2) Checking cellular connectivity speed.
- (3) Checking other device functionality when directed to do so by eMD Support Desk personnel.

h) Device Charging

The eMD device may be charged while on board using a company-issued cable and A/C power adapter. The eMD must not be left unattended while charging.

TRACK CAR RULES

803-S1. OPERATION OF SPECIALIZED MW EQUIPMENT

1. Operation Under Train Rules

The following specialized MW equipment is designed to reliably shunt track circuits. When the driver of this equipment is qualified on the operating rules **and** physical characteristics that apply to freight trains, and is accompanied by a second employee who is qualified on operating rules (see Rule 94), the equipment may run under the operating rules that apply to freight trains, instead of the operating rules that apply to track cars.

If the driver lacks either of these qualifications, or is not accompanied by a second employee qualified on operating rules, the Dispatcher must be notified and the equipment operated under track car rules. This equipment must also operate under track car rules when operating on tracks where DCS Rules are in effect.

Whenever the specialized MW equipment listed below is run under the operating rules that apply to freight trains, the employee at the controls must communicate the following information via the road radio channel, for each wayside signal encountered: name of signal aspect, track number, location, and direction of movement.

- a. **MDZ:** A track geometry unit composed of 3 pieces coupled together — the 09-32 or 09-16 cat tamper, high capacity ballast regulator, and dynamic track stabilizer. All 3 pieces must be coupled together to assure a positive shunt. If not coupled together, the Dispatcher must be notified and the equipment operated under track car rules.
- b. **08-Unimat Switch Tamper**
- c. **09-4S Combo Tamper**
- d. **BMS:** A high capacity ballast regulating and distributing machine. The BMS is designed to shunt with or without its conveyor or transfer car.
- e. **MTW-100:** An electric traction inspection and repair unit. If the MTW-100 is coupled to its single-axle trailer car, the Dispatcher must be notified and the equipment operated under track car rules.
- f. **MPMV:** The Multi-Purpose Maintenance Vehicle is composed of 2 pieces coupled together – a main power unit & the trailing control unit. If not coupled together (or operated with ballast car coupled between power unit & control unit), the Dispatcher must be notified and the equipment operated under track car rules.
- g. **MMU-1000:** The Mobile Maintenance Machine is composed of three cars coupled together - a main power unit, material car and a working car. All three pieces must be coupled together to assure a positive shunt. If not coupled together, the Dispatcher must be notified and the equipment operated under track car rules.

2. Maximum Speed of Equipment

The maximum speed for the equipment specified in part “1” of this instruction is 50 MPH not exceeding freight train speeds when operating under train rules, and 30 MPH not exceeding freight train speeds when operating under track car rules.

On the NHB Line, specialized MW equipment that is operating under the rules that apply to trains, must not exceed 30 MPH in ACSES territory, unless the MW equipment has operative on-board ACSES equipment.

3. Performing Maintenance

Where maintenance is performed by the equipment specified in part “1” of this instruction, a Form D must be issued in accordance with Rule 133. When operating under the direction of the Foreman in charge of the out-of-service track, the equipment may test over its own work area not exceeding 30 MPH, prepared to stop within one half the range of vision.

803-S1. (Cont'd)

4. Operation in Cab Signal System (CSS) Territory

When the equipment specified in part "1" of this instruction is operating without a Form D on an in-service track in CSS territory, it must not pass a signal displaying Stop and Proceed or Restricting unless authorized by the Dispatcher. The Dispatcher must not authorize this equipment to pass a Stop and Proceed, Restricting, or Stop Signal until he has determined that the block is not occupied. EXCEPTION: The Dispatcher may authorize movement into an occupied block in an emergency, or when the equipment will enter a block occupied by stored equipment.

Because of potential cab signal code leakage through the equipment, SI 561-S1 (page 337) will apply when a Unimat Switch Tamper, 09-4S Combo Tamper or MTW-100 is operating as a single unit, the BMS is operating without its conveyor or transfer car, or the MPMV is operating as a train with its power unit and control unit coupled. Before operating in CSS territory, the driver must advise the Dispatcher or Operator of the equipment consist, and remind the Dispatcher or Operator that SI 561-S1 applies.

Before operating in Rule 562 territory, where cab signals are used without fixed automatic block signals, the equipment specified in part "1" of this instruction must receive a signal displaying Rule 280a, Clear to Next Interlocking. If entering from a location where this signal cannot be displayed, the equipment must be operated under track car rules.

5. Identification of Equipment

When identifying the equipment specified in part "1" of this instruction by radio, telephone or Form D, employees must include the number of the leading piece of equipment.

803-S2. TRACK CAR AUTHORITY TO PASS STOP SIGNAL

Permission to pass a Stop Signal must not be issued to a track car via Form D Line 3 at either the initial or final interlocking listed on the Form D Line 2, or at any moveable bridge. Verbal permission (Rule 241) of the Dispatcher (or Operator when authorized by the Dispatcher) must be given at the aforementioned locations.

Note: This instruction also governs "additional Line 2" authorities.

813-S1. MOVEMENT OF MULTIPLE TRACK CARS

The first paragraph of Rule 813 is revised as follows:

Multiple track cars operating on the same Form D line 2 authority must regulate their speed to permit stopping *within one-half the range of vision* short of equipment ahead.

814-S1. DISPLAYING LIGHTS

Contractor equipment that includes an illuminated lighting tower may extinguish the headlights and leave just the running lights on when stationary and working on-track. This Special Instruction does not supersede the requirement of having the headlight on high beam when moving on any track.

815-S1. RAIL GRINDING UNIT

The Rail Grinding Unit track car is authorized to operate at 50 MPH, not exceeding the maximum speed for freight trains.

815-S2. CATENARY MAINTENANCE CAR

The MTW-100 (catenary maintenance car) may operate at 30 MPH when it is pulling its single-axle trailer car.

815-S3. TRACK STRUCTURE ASSESSMENT VEHICLE, AUTOMATED TRACK INSPECTION VEHICLE, NJT & CSXT TRACK GEOMETRY INSPECTION VEHICLE

The Track Structure Assessment Vehicle (TSAV, Amtrak A68402) and Automated Track Inspection Vehicle (ATIV, Amtrak A68335) are track geometry cars that may perform testing under Form D Lines 2 and 3 authority, in accordance with Track Car Rules 800 through 816.

Amtrak TSAV A68402 may operate governed by Train Type "C" speeds, not exceeding 50 MPH.

Unless otherwise restricted, TSAV & ATIV may operate not exceeding 20 MPH when diverting through switches and passing standing trains on adjacent tracks. TSAV & ATIV are not required to stop when being passed by trains on adjacent tracks.

If operating under Form D Line 4, under the direction of Foreman in charge of out-of-service track, TSAV & ATIV may test not exceeding 30 MPH, prepared to stop within one half the range of vision (see SI 133-S1, pg 322).

Note: New Jersey Transit's Track Geometry Inspection Vehicle (NJT-TGIV) and CSXT Track Geometry Inspection Cars (GRMS 1, GRMS 2) may operate on Amtrak property in the same manner as TSAV, except that they must not exceed the maximum freight train speeds.

815-S4. SPRING FROGS

Many main track hand operated and interlocked switches are equipped with spring frogs. Spring frogs contain, among other things, a fixed frog point, a moveable spring wing rail, a rigid wing rail, frog hold-down assemblies, and spring box. The frog makes use of a 27 foot guard rail (on the straight side). The spring frog design provides a continuous bearing surface for the wheel tread as it traverses through the frog point area. The following photograph and diagrams illustrate the various spring frog components.

Switches equipped with spring frogs were installed at these interlockings, when this page was last revised: *NHB Line* - Davisville, Lawn, Mansfield; *NYP Line* - Hudson, Rea, Hunter, Lane, Union, County, Midway, Morris; *PH Line* - Leaman, Cork; *PW Line* - Davis, Prince.

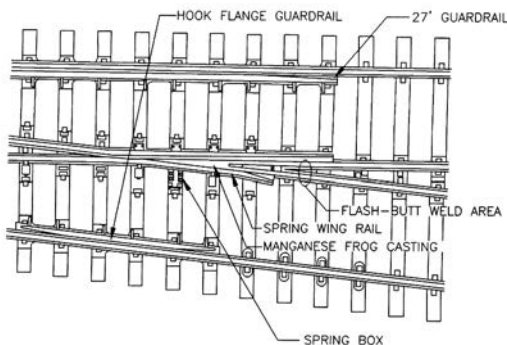
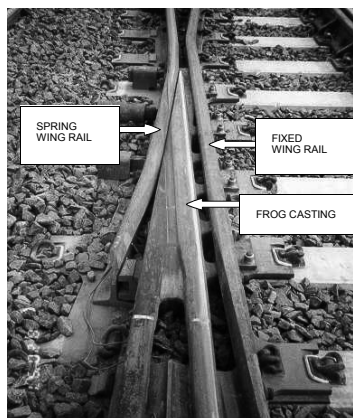

MANGANESE SPRING FROG LAYOUT

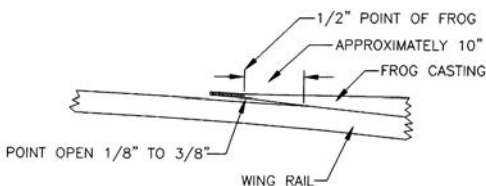

DETAIL OF SPRING FROG POINT AREA

815-S5. BRANDT TRUCK TRACK CARS: MAXIMUM SPEED

Unless otherwise restricted, the following maximum speeds apply to the movement of Brandt Trucks:

- Lite or when pulling equipment..... 20 MPH
- When pushing/shoving equipment..... 10 MPH

900-S1. DISPATCHER

Where the Operating Rules and Special Instructions make reference to Dispatcher such references will apply to the Console Operator at the PSCC.

940-S1. AMTRAK CONDUCTORS AND ASSISTANT CONDUCTORS

During the job briefing, the Conductor must designate himself or another crew member as responsible for door operation. Prior to notifying the Engineer that the train is ready to depart each station, the designated employee must ensure all forward and rearward doors are closed and take position in the remaining open vestibule door to observe the platform. The designated employee must continue to observe from the open door until the train has cleared the platform, taking necessary action to prevent passengers from boarding, exiting or otherwise fouling the moving train.

Exceptions:

- On equipment where it is not possible to move the train if any door is open, the designated employee must *visually* verify from the platform that all forward and rearward doors are closed before closing the local door.
- **HST Exception:** This instruction does not apply to crews of High Speed Trainsets (HST). HST crews are governed by SI 940-A1, page 372.

940-S2. CONDUCTORS AND ASSISTANT CONDUCTORS

As soon as their trains are ready to receive passengers, Conductors will see that their Assistant Conductors and Train Attendants are properly located to render any necessary assistance in loading passengers.

Conductors and Assistant Conductors will, while loading passengers, frequently announce the routes and names of the principal stations at which the train will stop. They will also direct passengers to pass promptly to inside of cars and not allow them to stand on car platforms. They will give careful attention to the handling of passengers and will not give signals to start their train while passengers are getting off or on.

Conductors in charge of trains arriving will remain with their train to supervise the prompt and safe detraining of their passengers.

When trains are being moved under the direction of a Yard Conductor and passengers are on board, Conductor and Assistant Conductors will station themselves properly and render necessary assistance to the Yard Conductor, and will not allow passengers to detrain or entrain until it is known that it is safe to do so.

When leaving their trains, Conductors and Assistant Conductors will remove all equipment such as markers, lamps and flag cases, and deliver all this equipment to designated location. They must see that fusees or other articles are not left on or about cars, station platforms or tracks.

Where the term Assistant Conductor is used in these instructions, it applies also to Trainmen, Flagmen and Baggage men.

940-S3. WORK, WIRE, AND WRECK TRAIN CONDUCTORS

Conductors of Work, Wire, or Wreck Trains must call the Assistant Chief Train Dispatcher when reporting for duty, and provide the following information: *job symbol, crew names and employee numbers, and on duty time*. At the end of their assignment, they must again call with an *off duty time*.

940-S4. CONDUCTOR CERTIFICATION

Conductors that have received a Conductor Certification Card must have it in their possession while on duty as a Conductor and must be prepared to display the certification card upon request from a representative of the FRA, Railroad Official or State Inspector.

941-S1. AMTRAK TRAIN & ENGINE CREW RESPONSIBILITY: and DEPARTING PASSENGER STATIONS

951-S1.

Prior to departing a passenger station where a fixed signal governing the train's departure is clearly visible, the Conductor or Assistant Conductor of the trains listed in the table below must verbally communicate permission to proceed, and must include the phrase "on signal indication" in their communication to the Engineer:

Example: "Amtrak Train No. 95, OK to proceed on signal indication, over."

This communication must be made via radio, except the train's intercom or PA system may be used when radio congestion would cause train delay. The Engineer must respond by communicating train identification, signal name, and track number. Conductors do not need to respond to this transmission:

Example: "Amtrak Train No. 95, Track 8, OK to proceed with a (signal name), out."

Crews of trains listed below must include the phrase "on signal indication" when communicating permission to proceed to their Engineer:

Trains	Location
Amtrak	Entire NEC
MARC	Washington Terminal
NJT	30 th St. Station, Philadelphia
NJT	NYP & NYT Lines

942-S1. POSITION OF CONDUCTOR ON ENGINE CONSIST

Rule 942 does not apply during switching operations.

950-S1. ENGINEER TRAIN HANDLING CERTIFICATION FORM

Engineers qualifying on the physical characteristics of any portion of the Northeast Corridor will not be considered qualified on the physical characteristics, and must not accept an assignment to operate over the territory involved, until after they have been certified on their train handling proficiency over the territory by a home road supervisor with engine service experience.

After an Engineer qualifies on the physical characteristics of a portion of railroad, an Amtrak Operating Practices Department Representative will complete PART 1 of form NRPC 3290 "AMTRAK PHYSICAL CHARACTERISTICS AND TRAIN HANDLING CERTIFICATION FORM FOR ENGINEERS".

The Operating Practices Department Representative will retain a copy of this form and will also give a copy to the qualifying Engineer. The qualifying Engineer must then present the form to a home railroad supervisor with engine service experience who is qualified on the physical characteristics of the territory involved who MUST RIDE with

950-S1. (Cont'd)

the qualifying Engineer while he operates over the territory involved within 6 months of the date of qualification.

If the Engineer is unable to have a home railroad supervisor certify him during this period, the Engineer must requalify and obtain a new form. When the supervisor is satisfied with the Engineers train handling proficiency over this territory, he must complete and sign PART 2 of this form, and forward it to the Amtrak Operating Practices Department Representative shown in PART 1.

EXCEPTION: The 6 month requirement will not apply to Engineer Trainees during their OJT phase of training.

954-S1. AIR BRAKE TEST

At points where mechanical forces are employed and on duty, Amtrak Engineers will accept the inspection of the mechanical forces for the air brake test as specified in Rule 2.3 of the AMT-3. Employee making the 2.3 air brake test will complete the Locomotive Initial Air Brake test section on the Locomotive Inspection Form.

F-A1. FIRE SUPPRESSION SYSTEM ON HST's & HHP-8's

HST's and HHP-8's are equipped with an automatic fire suppression system. In the event of a fire in the central block (engine room), an alarm will sound in the operating cab. A "Fire Detected" indication will appear on the POD screen, and a "Fire Detected" indication will also appear in the alarm section of the MFD-1 screen. On HST's, the specific power car that caused the alarm will be identified. Maximum propulsion speed is then limited to 20 MPH. If no action is taken, automatic fire suppression occurs after 2 minutes (FE-13 chemical discharges into the central block), and power car or locomotive becomes inoperable.

To silence alarm, press F7 or F8 key on MFD-1.

If train is inside a tunnel at the time of alarm, and conditions warrant, "FIRE SUPP INHIBIT" button on leading power car or HHP-8 locomotive should be pressed to inhibit loss of propulsion power, so that train may clear tunnel (see HST note below). This button is located on the rear cab wall switch panel.

After clearing tunnel, if it is ascertained that there is a fire condition, the fire suppression system must be manually activated by pressing "FIRE SUPP ACTIVATION" button on the rear cab wall switch panel. On an HST, this button must be activated on the power car on which the fire condition exists.

HST Note: On HST's, if alarm is triggered by rear power car, the fire suppression system cannot be inhibited from the leading power car, since the "FIRE SUPP INHIBIT" button is not a trainlined function. Main circuit breaker will open on trailing power car if system is not inhibited from that power car.

20-A1. BELL ON HHP-8 ENGINES & HST's

In yards and stations, Engineers on HHP-8 engines and HST's must avoid using the horn activation switch to activate the continuous bell feature, except when the use of the horn is also required. The bell activation switch on this equipment will activate the bell continuously until the switch is pressed again.

21-A1. HST COMMUNICATING SIGNAL APPLIANCE

HST's are not equipped with a communicating signal appliance. Conductors must use proper radio voice communication or hand signals to authorize the Engineer to proceed. (The intercom function of the PA system may be used as a back-up means of communication.)

34-A1. STATION STOP MARKERS FOR ACELA EXPRESS TRAINS

Acela Express (HST) Station Stop Markers are installed in various stations throughout the NEC. The marker is a black sign with a white reflectorized "E." Acela Express trains must stop the front end adjacent to the letter "E." During their job briefings, Conductors and Engineers must discuss train stop locations for stations where "E" signs are not installed, in order to best accommodate passenger boarding and detrainning. Currently, "E" signs are in service at the following locations:

Station	Track(s)	Movement Direction(s)	Notes
Baltimore	4, 6, and 7	Northward & Southward	...
Wilmington	2 & 3	Northward & Southward	...
Philadelphia	3, 4, 5 & 6	Northward & Southward	...
Metro Park	1	Eastward	...
New London	1 & 2	Eastward & Westward	1
Providence	1 & 2	Eastward & Westward	...
Route 128	1 & 2	Eastward & Westward	...

Note 1: When first class car is on head end, first "E" must be used. When first class car is on rear, second "E" must be used.

34-A2. NEW LONDON: BRIDGE PLATES FOR HST STOPS

Train crews of HST's making station stop at New London must use bridge plates on high level platform when assisting passengers getting on or off trainsets. After use, bridge plates must be properly stored and secured.

37-A1. ENGINES & EQUIPMENT: MAXIMUM SPEEDS UNLESS OTHERWISE RESTRICTED

HIGH SPEED TRAINSET (HST) CARS	Speed
2000-2039 (power cars), 3200-3219, 3300-3319, 3400-3419, 3500-3559, & Instrumented Car 10003	150
With deflated air springs	90
With over inflated air springs:	
Non-diverting routes	30
Diverting routes	15
HST Power Cars 2000-2039 with shroud raised on:	
Leading Power Car	50
Trailing Power Car	125
HST towed with shroud raised	125
HST operating without either a 3200 or 3400 series car (or the instrumented car 10003) adjacent to each powercar	125
HST Power Cars 2000-2039, Lite	50
HST Power Cars 2000-2039, Multiple Lite	50

41-A1. TILT SYSTEM OPERATION ON HST's

1. Manually Disabling Tilt in Snowy Conditions:

When snowfall which can become packed in HST undercarriage areas accumulates on the right of way, it may become necessary to disable the HST's tilt system to avoid damage to tilt system components. When such conditions are determined to exist, Conductor/Engineer will receive verbal instructions to manually disable the HST tilt system in accordance with this instruction (SI 41-A1, paragraph 1). These instructions will generally be delivered when inquiring about Form D's or other instructions as per SI 165-S1 (page 330), but may also be delivered by the Dispatcher when en route, should conditions require.

- When instructed to manually disable tilt as per this instruction, Engineers must manually disable the HST tilt system on the lead power car by positioning the "Tilting Switch" to the "Disable" position.
- Engineers must note this condition on the MAP-100 as "Tilt disabled per SI 41-A1 para. 1".
- Once tilt has been disabled in accordance with this instruction, it must remain disabled until the train reaches its final terminal.

2. "Tilting Fault" Alarm

In the event of tilt system failure due to a "Tilting Fault" alarm, the following instructions and reduced speeds apply. The Engineer must inform the Conductor and Dispatcher of the tilt system failure as soon as possible, specifying the type of failure, car number and truck ("A" or "B").

▸ **"Tilting Fault" Alarm:** Train Type "B" speeds will govern.

Note: Operation at Train Type "B" Speeds: When an HST is required to operate at Train Type "B" speeds as outlined above, its maximum speed is not capped at 125 MPH; The Train Type "B" maximum speeds and speed restrictions that are listed in Special Instructions 37-B1, 37-N1 and 37-P1 will govern. On the NHB and NYP Lines, there are a number of locations where Train Type "B" speeds exceed 125 MPH.

41-A2. SIDE MIRRORS: HST POWER CARS & HHP-8 LOCOMOTIVES

Due to the potential for mirrors to foul the adjacent track, side mirrors on HST power cars and HHP-8 locomotives may be extended only when **(1)** operating on yard tracks at speeds less than 15 MPH, **(2)** standing in a station and mirror is extended only on platform side of train, **(3)** wide track centers exist on the affected side of the train, or **(4)** protection on the adjacent track has been provided by the Dispatcher.

Auto-Retraction Feature: When changing ends or taking charge of equipment (such as when operating into an HST Trainwash facility), crews operating HST's and HHP-8 locomotives must ensure that side mirrors on leading and trailing cabs are manually closed prior to movement. Auto-retraction feature must not be depended upon to close side mirrors.

NOTE: Mirrors must **not** be extended:

- ▶ When in tunnels, unless train is standing.
- ▶ When operating through car washers.

41-A3. HST STATION STOPS; PROPER USE OF HST PORTABLE FOLDING STEPS

Station Stops: HST's must use high level station platforms to receive or discharge passengers. When unforeseen circumstances require that HST's receive or discharge passengers at a location other than a high level platform, HST portable folding steps must be used. These steps are stored on the end cars adjacent to the power cars, in a compartment under the vestibule.

Portable Steps: When HST portable folding steps are deployed, they will foul the adjacent track at most locations. Therefore, whenever necessary to deploy portable steps, the crew must first contact the Dispatcher and obtain a hold on the track to be fouled. If necessary to operate a rescue train on the track fouled by these steps, the Dispatcher must issue the following Form D line 13 to the rescue train: "Approach disabled train located at (disabled train location) on track (track on which disabled train is standing) prepared to stop short of portable steps fouling track (track to be fouled by portable steps)"

47-A1. ELECTRICAL OPERATION AT HSR FACILITIES

1. Entrance Door Catenary Buffer Zone - Prior to entering an HSR Servicing Facility, permission must be obtained from a Supervisor on the ground. Before granting permission for a train with raised pantographs to proceed into the building, Supervisors must ascertain that the entrance door catenary buffer zone on the track to be used is energized. The red and green indicator lights do **not** convey the status of the entrance door catenary buffer zone.

2. Catenary Status Indicator Lights - HSR Servicing Facilities are equipped with red & green lights to indicate status of catenary within the Facility. A red light indicates catenary within the Facility is energized. A green light indicates catenary within the Facility is **not** energized and electric engines with pantograph raised must **not** enter the Facility. If both indicators are dark, an M of E foreman must be contacted to ascertain that catenary is energized before attempting movement into the facility with pantograph raised.

47-A2. HST SINGLE POWER CAR OPERATION

When snow, sleet or mechanical conditions require single power car operation, the Engineer will be directed by the Train Dispatcher to operate with a single power car, with one pantograph raised. When so directed, the Engineer must follow the single power car operation and setup instructions contained in the System General Road Foreman Notices.

72-A1. HST: DEFECTIVE CONDITIONS REQUIRING 125 MPH MAXIMUM SPEED

If any of the following systems are inoperative or bypassed on an HST, the HST must not exceed 125 MPH, and the Dispatcher must be promptly notified:

1. The Integrated Truck Surveillance Unit (ITSU) on any power car or coach, which includes:
 - a. The truck hunting accelerometer sensor on HST power cars and coaches.
 - This apparatus must be in service before the HST leaves its initial terminal, which is noted on the MAP 100 form.
 - If an accelerometer sensor fails en route, HST's in turn around service may continue to the equipment's end point, not exceeding 125 MPH (see SI 72-A5, pg 368).
 - When taking charge of equipment at any terminal other than the original passenger terminal (as noted on MAP 100 & MAP 101), the Engineer must notify the Conductor & Dispatcher of inoperative accelerometer sensor (status displayed on MFD-1 screen) and 125 MPH maximum speed.
 - b. * The on-board hot bearing detection on any power car or coach (see SI 72-A3, pg 365).
2. * The alertor on the leading power car.
3. * Both the POD (Primary Operating Display) and the MFD-1 (Multi-Function Display) screen in the cab of the leading power car.
4. The fire detection system on either power car.
5. The door status display in the cab of the leading power car.

Note: Devices marked with an asterisk (*) must be in service before the HST leaves its original passenger terminal or turnaround location. See Rule 123 for additional instructions on movement with a defective alertor. See Rule 22 for additional instructions on movement with a defective headlight.

72-A2. USE OF TEMPILSTIK

High Speed Trainset coaches and power cars, and HHP-8 engines are equipped with **outboard** journal bearings. When necessary to check an HST coach or power car or HHP-8 engine for an overheated journal bearing, a 219° F or 212° F Tempilstik must be applied to the top of the journal bearing case, where it passes through the truck frame.

72-A3. HIGH SPEED TRAINSET: ON-BOARD HOT BEARING DETECTION SYSTEM

Each High Speed Trainset (HST) power car and coach is equipped with an **Integrated Truck Surveillance Unit (ITSU)**, which is designed to warn the crew if the system detects an overheated journal bearing, or a system fault. The system operates with the following components:

- ▶ Journal bearing temperature sensors that are mounted on each of the car's bearings, and connected by cables to each car's ITSU.
- ▶ Trainline connection to enable the leading HST power car to indicate when a hot bearing or problem with an ITSU is detected.
- ▶ The ITSU control panel that is located near the bottom of electric locker No. 1 in both the HST power cars and coaches.

Hot Journal Alarm: When a temperature sensor detects an abnormal journal bearing temperature (212° F), ITSU triggers a "Hot Journal Alarm."

Bearing Sensor Fault Alarm: When ITSU detects a defect in one of the journal bearing sensors, it triggers a "Brg Sensor Fault Alarm." The specific bearing sensor location and vehicle number that triggered the alarm will be displayed in the alarm box of the MFD-1 screen, for example: "BEARING SENSOR FAULT L1 3319."

72-A3. (Cont'd)

When either of the above alarms is triggered, the appropriate ITSU front panel indicator illuminates, the "Onboard Failure" trainline becomes energized, and the "ONBOARD FAILURE" indicator on the Engineer's overhead switch panel activates. A "HOT BEARING" alarm will appear on the POD (Primary Operating Display). The train's movement is then restricted to 20 MPH.

When the "HOT BEARING" alarm activates, the following actions must be taken:

1. Stop the train as soon as safe handling will permit.
2. The Engineer must determine car and bearing location which caused the "HOT BEARING" alarm by checking the alarm section of MFD-1 (Multifunction Display 1) for specific information regarding car number and bearing location. The Train Crew can also check the MFDB screen in the Crew Café car, by accessing the main page in the alarm section to obtain specific information regarding car number and bearing location.
3. Take the specific actions listed below, based on the alarm type:

A. HOT BEARING ALARM (Flashing Red LED):

1. Crew must determine from the MFD screens or the ITSU panel which car and bearing caused the "Onboard Failure" alarm. A member of the crew must check the suspected overheated bearing with a 219° F Tempilstik per AMT-3 Section 9.
2. Notify the Dispatcher and the Engineer of the results of any inspections, and record ITSU hot journal bearing alarm (flashing red LED) information using form MAP 21A (coach) or form MAP 100 (power car).
3. **If a hot bearing is found**, Dispatcher will provide instructions for transferring passengers and moving train to repair location.
4. **If no hot bearing is found**, cutout the system using the cutout switch on the ITSU panel. Proceed not exceeding 80 MPH to a location where mechanical forces are available to inspect car.
5. If at the mechanical inspection location, mechanical forces determine there are no hot bearings, the train may proceed not exceeding 125 MPH as specified in SI 72-A1 to its final terminal, regardless of whether or not the same ITSU hot journal bearing alarm (flashing red LED) remains, or activates again. (NOTE: Wayside detector actuations must continue to be handled in accordance with applicable instructions).
6. When an ITSU hot journal bearing alarm occurs before a crew change location, the incoming crew must be advised of any alarm light that remains illuminated, any speed restriction that is in effect, and whether a mechanical inspection is required. If the outgoing crew cannot personally give this information to the incoming crew, they must ask the Dispatcher to relay it.

B. SENSOR FAILURE ALARM (Flashing Yellow LED):

1. If a "Sensor Failure Alarm" caused the "Onboard Failure" indicator to activate, determine from the MFD screens or the ITSU panel which car and bearing sensor caused the "Onboard Failure" alarm.
2. Bypass the defective sensor by pressing the self-test and lamp test buttons simultaneously. The sensor failure indicator should change from flashing to steady illumination, and the local alarm acknowledgment indicator will be illuminated. Proceed at NORMAL SPEED to the train's final terminal.
3. If pressing the self-test and lamp buttons simultaneously fails to bypass the defective detector or the defective sensor failure alarm occurs a second time, the system must be cut out using the cut out switch on the ITSU panel, and the train may proceed not exceeding 125 MPH as specified in SI 72-A1 to its final terminal.
4. Notify the Dispatcher and the Engineer of the sensor failure alarm (flashing yellow LED), and record it on Form MAP21A (coach), or MAP 100 (power car).

72-A3. (Cont'd)

ADDITIONAL ITSU INFORMATION:

ITSU Hot Bearing Indicator Lights:

- **Green** = Normal Operation
- **Flashing Red** = Alarm
- **Flashing Amber** = Sensor Failure
- **Steady Amber** = Sensor Bypassed

Other ITSU System Lights:

- An amber "Alarm Sensor" light indicates sensor failure
- A red "System" light indicates system failure
- The green CIN (Car Internal Network) "Active" and red "Unconfigured" lights indicate the status of the car's internal network
- The System "Power," "Ready," and "Failure" lights indicate ITSU system status
- "Local Alarm Acknowledgment" light indicates if any system sensor has been bypassed

Bypassing Defective Sensor:

To bypass a defective sensor, press simultaneously on the ITSU Self Test and Lamp Test buttons. In case of multiple sensor failures, one activation of the degraded mode bypasses each defective sensor of the affected ITSU subsystem(s).

Cutting Out ITSU:

To cut out the ITSU, use the sealed CUTOFF switch. If the ITSU sealed CUTOFF switch fails, use the ONBOARD TL switch (cab rear wall switch panel) to recover train operation. (See SI 72-A1, page 365 regarding operation with ITSU cut out.)

72-A4. HHP-8 LOCOMOTIVE: ON-BOARD HOT BEARING DETECTION SYSTEM

Each HHP-8 locomotive is equipped with an **Integrated Truck Surveillance Unit (ITSU)**, which is designed to warn the Engineer if the system detects an overheated locomotive journal bearing, or a system fault. (On the HHP-8, ITSU monitors only the locomotive; coaches equipped with on-board hot bearing detection are trainlined to the HHP-8's computer alarm screens, but are not connected to ITSU.) The system operates with the following components:

- ▶ Journal bearing temperature sensors that are mounted on each of the locomotive's bearings, and connected by cables to the ITSU.
- ▶ On coaches that are so equipped, journal bearing temperature sensors that are mounted on each of the coach's bearings, and connected by cables to the HHP-8's on-board computer system, and its various display screens.
- ▶ The ITSU control panel that is located in the "R" end equipment room, Engineer's side, near the bottom of electric locker No. 1.

Hot Journal Alarm: When a temperature sensor detects an abnormal locomotive journal bearing temperature (212° F), ITSU triggers a "Hot Journal Alarm."

Bearing Sensor Fault Alarm: When ITSU detects a defect in one of the locomotive journal bearing sensors, it triggers a "Brg Sensor Fault Alarm." The specific bearing location and locomotive number that triggered the alarm will be displayed in the alarm box of the MFD-1 screen, for example: "HOT JOURNAL L1 651."

When either of the above alarms is triggered, the "ONBOARD FAILURE" indicator on the Engineer's overhead switch panel will activate. The train's movement is then restricted to 20 MPH.

If a locomotive bearing triggered the alarm, the appropriate ITSU front panel indicator will illuminate, and a "HOT BEARING" alarm will appear on the POD (Primary Operating Display). The specific bearing location and locomotive number that triggered the alarm

72-A4. (Cont'd)

will be displayed in the alarm box of the MFD-1 screen, for example: "HOT JOURNAL L1 651."

If a coach bearing triggered the alarm, a "COACH HOT JOURNAL" warning will appear in the alarm box of MFD-1. Engineer must notify Conductor to check coach on-board hot bearing detector panels to determine which coach activated the alarm.

When the "HOT BEARING" or "COACH HOT JOURNAL" alarm activates, the following actions must be taken:

1. Stop the train as soon as safe handling will permit.
2. A member of the crew must check the suspected overheated bearing with a 212° F or 219° F Tempilstik. On locomotive, Tempilstik must be applied to the top of the journal bearing case where it passes through the truck frame.
3. Notify the Dispatcher and the Engineer of the results of any inspections, and record ITSU hot journal bearing alarm (flashing red LED) information on form MAP 100.
4. **If a hot bearing is found**, Dispatcher will provide instructions for transferring passengers and moving train to repair location.

IF NO HOT BEARING IS FOUND:

1. For alarms caused by a **coach bearing**, follow applicable instructions published in AMT-3, Air Brake and Train Handling Rules and Instructions.
2. For alarms caused by **locomotive bearing**, or **locomotive bearing sensor failure**, follow the procedures contained in Special Instruction 72-A3, item **A(4)** on page 366, through item **B(5)** on page 366.

72-A5. TRUCK HUNTING ON HIGH SPEED TRAINSETS AND HHP-8 ENGINES: ITSU OPERATION

High Speed Trainsets (HST) and HHP-8 engines are equipped with an Integrated Truck Surveillance Unit (ITSU) that monitors the equipment for truck hunting.

The truck hunting apparatus must be in operative condition when departing the original passenger terminal, which is noted on the MAP 100 & 101 forms. However, trains that experience an en route failure of the truck hunting apparatus when operating in turnaround service may continue to the equipment's end point not exceeding 125 MPH. When taking charge of equipment at any terminal other than the original passenger terminal (as noted on MAP 100 & MAP 101), the Engineer must notify the Conductor & Dispatcher of inoperative accelerometer sensor (status displayed on MFD-1 screen) and (for HST's) 125 MPH maximum speed.

When an ITSU truck hunting alarm occurs, the Engineer must:

1. Immediately reduce train speed in 5 MPH increments until the alarm has ceased. Once the alarm has ceased, the Engineer may attempt to resume Normal Speed, unless the alarm continues to sound when a higher speed is attempted.
2. In the event that alarm does not cease upon reduction in train speed, a full stop may succeed in clearing alarm.
3. If the actions in steps 1 & 2 above do not clear the truck hunting alarm, bypass accelerometer sensor by pressing the Self Test and Lamp Test buttons simultaneously. [Refer to section (B) of SI 72-A3, page 367, for additional ITSU information.] Engineer must note on MAP 100 the vehicle and truck on which the ITSU accelerometer sensor has been bypassed.
4. **Once accelerometer sensor has been bypassed, train must not exceed 125 MPH.**
5. Promptly notify the Dispatcher of the:
 - a. Mile Post location where the truck hunting alarm occurred.
 - b. Speed at time of the alarm.
 - c. Time of the alarm.

72-A5. (Cont'd)

d. Unit on which the alarm occurred. (ITSU system on HST monitors all cars)

AND

e. Accelerometer sensor bypass status - if bypassed, note 125 MPH maximum speed.

The Dispatcher must report this information to the CNOC Power Desk, so that arrangements can be made to have the equipment inspected.

When an ITSU truck hunting alarm occurs under the conditions described below, the Dispatcher must issue a 30 MPH speed restriction on the affected track at the affected location, until an inspection has been performed by the Track Department:

1. An HST experiences a truck hunting alarm on 3 or more cars of its trainset at a single location.

OR

2. Consecutive HST or HHP-8 locomotive movements experience a truck hunting alarm at the same location (e.g., 2 consecutive HST's, an HST followed by an HHP-8 locomotive, etc.).

116-A1. MOVEMENT OF LITE HST POWER CARS

When an HST power car is operated lite from other than the leading end, crew members must take action to properly control the movement. When switching, movement must be preceded by a crew member, due to the following factors: **(1)** There are no sill steps or end / side handholds on the rear of HST power cars, therefore employees cannot control movement by riding rear of power car. **(2)** Back up hoses are incompatible with the quick disconnect fitting on HST brake pipe, and therefore cannot be used to control movement.

137-A1. HST & HHP-8 BRAKE RELEASE - RESCUE TOWING & EMERGENCY TUNNEL EVACUATION

1. HST's – Should it become necessary to tow a High Speed Trainset (HST), the power car shroud must first be raised to enable access to the coupler. The following steps and accompanying diagrams explain how to raise the power car shroud. Use the diagram key number shown in parentheses () for assistance in locating the various shroud components. Safety glasses and gloves must be worn while performing the following tasks. A long handled allen wrench is stored in the power car emergency supply locker, and must be used to open the power car shroud.

1. Spring Latch
2. Hood
3. Lateral Flap
4. Shroud
5. Handle
6. Shroud Unlocking Lever
7. Collision Block
8. Quick-Release Pin
9. Pin Receptacle
10. Retaining Pin
11. Release Handle
12. Shroud release latch

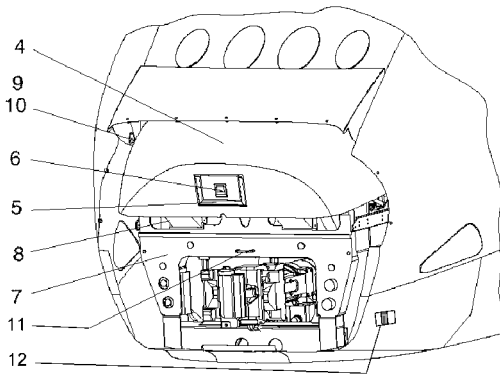
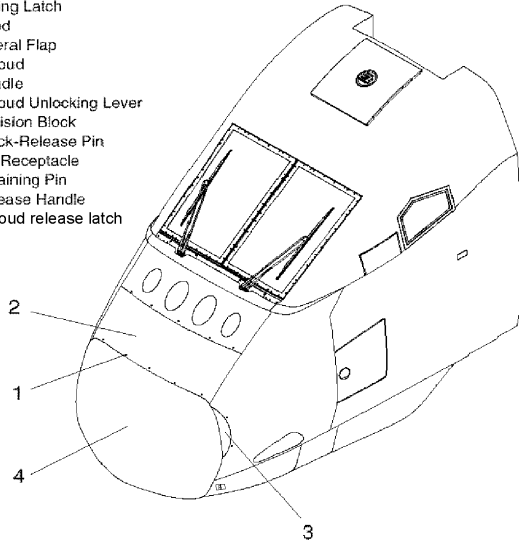

- a. Using the long handled allen wrench, loosen the 2 allen fasteners ($\frac{3}{4}$ turn) on each lateral flap (#3) on each side of the train. Push the lateral flaps in until they latch.
- b. Using the allen wrench, loosen the 5 spring latch allen fasteners (#1) on the hood $\frac{3}{4}$ turn. Since the hood is spring loaded, it may need to be held down until all of the allen fasteners are loosened.
- c. Release safety latches (#12) on left & right sides.

137-A1. (Cont'd)

- d. When the hood is open, squat down and lift the handle on the shroud (#5). Lift the shroud to its balance point. Reposition yourself. If required, have another crew member assist, and then lift the shroud all the way open. (Shroud has springs on each side.)
- e. Shroud must now be manually locked open with quick release pins on each side (#8). Pins must be inserted in holes provided after being removed from storage position.
- f. Hood must now be manually locked open with retaining pins on each side (#10). Pins must be inserted in holes provided after being removed from storage position.
- g. Prepare brake pipe and main reservoir hoses for coupling. There is a plate under the coupler head that may be removed to improve accessibility to the angle cock and main reservoir cock. Remove hoses from glad hand holders.
- h. The HST is equipped with a self centering coupler that always remains centered and cannot be moved laterally for coupling. Therefore, the rescue engine's coupler must be aligned with the HST coupler. Leaving the knuckle closed on the power car is the best method. However, if necessary, you may open the knuckle on the HST. Remove the coupler assembly from the front of the power car breast plate and insert the coupler assembly in the rotary lock lift. Then lift on the coupler assembly to open the knuckle.
- i. When rescue engine is coupled, speed must not exceed 2 MPH to avoid damaging the coupler shear pins. Ensure rescue engine is stretched. Also ensure that Engineer has cut out the emergency magnet valve (located on the engineer's side of the power car, at the rear) on both power cars, to avoid undesired emergency application in the event of low battery voltage. Couple brake pipe and main reservoir hoses. (Both main reservoir and brake pipe hoses must be coupled, as this will assist in releasing parking brakes.) Open brake pipe angle cock and main reservoir cock. Turn HEP switch to OFF. Check MFD-2 to ensure that HEP output is off. Lower pantographs on HST and move pantograph selectors to OFF on both power cars.
- j. Connect 480 volt cables on right side. Only 2 cables are required. After rescue engine 480 volt output breaker is closed, HEP will be supplied to the train.
CAUTION: HEP must only be provided from 1 source!
- k. When performing the brake test, check the train brake & parking brake status on MFD-2 using the friction brake status screen, in addition to a visual inspection of trailing power car.

IN CASE OF DIFFICULTY IN RELEASING BRAKES:

- l. If brakes cannot be released on one or more trucks due to braking system defect, trucks may be cut out on individual coaches by using the truck cut out cock inside each car, which is located inside the cabinet behind the emergency brake valve. On power cars, the truck cut out cocks are located on the outside wall of the equipment room.
- m. The procedure in the next paragraph should only be used if all other means of moving the HST have failed. Under the conditions outlined below, the HST has no brakes or parking brakes. Therefore, it is imperative that the coupling is stretched prior to brakes being cut out in the manner described.
When a High Speed Trainset experiences an air brake system malfunction which prevents train movement, after helper train or locomotive has been coupled to HST, brakes may be released on the HST cars using the "No Brake" switch on each car. Power Cars must have brakes released manually with truck cutouts inside car body and parking brake cutout on air brake rack. Train can then be checked for brakes released on MFD-2. Train should then proceed not exceeding 10 MPH to a safe location where brakes can be cut back in.

137-A1. (Cont'd)

- n. When the rescue engine is uncoupled the HST Power Car shroud must be lowered and locked in position tightening the allen screws with the allen wrench. If it is not possible to lower the front shroud crew must ensure that locking pins are inserted in the holes provided to prevent movement of hood and shroud. Speed is restricted (see SI 37-S5, page 289) until the shroud is lowered and secured in the down position.
2. **HHP-8 Locomotives** – Should it become necessary to tow an HHP-8 powered train, the following instructions must be observed.
 - a. When coupling to HHP-8, both main reservoir and brake pipe hoses must be coupled. This will assist in releasing parking brake on HHP-8.
 - b. Emergency magnet valve (located on “F” end, Engineer’s side, in equipment room under emergency valve on air brake rack) must be opened, to avoid undesired emergency application in the event of low battery voltage.
 - c. If brakes cannot be released on HHP-8 trucks, trucks may be cut out using the truck cut out cocks located on the outside wall of the equipment room, and parking brake cutout on air brake rack.

940-A1. HST SIDE DOOR OPERATION

1. **Engineer’s “Doors Closed and Locked” Switch** – HST’s are equipped with a sealed “Doors Closed and Locked” switch that is located on the Engineer’s right switch panel. When in the “Normal” position, traction power **cannot** be developed when any HST side door indicates as not being fully closed. Once placed in the “Bypass” position, the HST **can** develop traction power when one or more side doors indicate as not being fully closed. Therefore, the Engineer must not place this switch in the “Bypass” position without permission of the Conductor.

2. **Door Control Station Operation** – During the job briefing, the Conductor must designate himself or another crew member as responsible for door operation. When the Conductor or other designated crew member activates a Door Control Station in order to operate HST side doors, all other Door Control Stations in the train are automatically disabled. The Door Control Station cannot be activated until the train has come to a complete stop. After stopping, the Door Control Station (DCS) can be activated by inserting a coach key into the “DCS” key switch in the lower left hand corner of the Door Control Station panel, and turning the key counterclockwise to the “ON” position. You can determine when the Door Control Station has become active, because the “DCS ACTIVE” indicator light near the top of the panel will illuminate. To deactivate the Door Control Station, the coach key is turned to the vertical “OFF” position and removed.

NOTE: Due to the design of the “DCS” key switch, it is possible to remove your key without actually turning the key switch completely to the “OFF” position. This leaves the Door Control Station in the active mode (“DCS ACTIVE” light illuminated), thereby preventing all other Door Control Stations in the train from functioning. In order to avoid the delay associated with attempting to find a Door Control Station that was accidentally left active, **always** check to be sure the “DCS ACTIVE” indicator light has gone out after removing your key from the “DCS” key switch.

3. Arriving at Stations –

a. **Prior to Arrival:** When practical, Conductor or other crew member designated by the Conductor should try to position themselves at the Door Control Station that will be closest to the main stairway or corridor used by passengers at that station. After train has stopped, Conductor or designated crew member will take control of all side doors by activating his or her Door Control Station (place the “DCS” key switch in “ON”

940-A1. (Cont'd)

position). No other crew member should operate a Door Control Station unless directed to do so by the Conductor.

b. Opening Doors: Conductor or other designated employee must open the Local door first. *Only after the Local door has **completely** opened* can forward and rearward doors be opened by depressing the forward and rearward Open buttons. Since this door open process involves a slight delay, crew members may wish to inform their passengers via the P.A. system: "Please wait, the doors will open momentarily."

4. Departing Stations – The following platform observation requirements apply to the HST, in lieu of the procedure in Special Instruction 940-S1:

a. Door Closing Sequence: Forward and rearward doors must be closed first. Forward and rearward Close buttons must be pressed simultaneously, or within ½ second of each other, in order to close both sets of doors simultaneously. If more than ½ second elapses between activation of forward and rearward close buttons, only one set of doors will close, and the other set of doors will not respond to Close button commands until the verbal announcement has completed. After instructions in paragraph "b" below are complied with, Local door can be closed.

b. Checking Doors From Platform: After the crew signals the Conductor that it is OK to proceed, the Conductor will key all forward and rearward doors closed from his or her location, visually verify from the platform that all doors are closed properly, close the Local door, and then signal the Engineer to proceed.

5. Door Malfunction – If a door malfunction prevents traction power from being developed, the Conductor must notify the Engineer to place the "Doors Closed and Locked" switch in the "Bypass" position. If train is moving when Engineer loses "Doors Closed & Locked" indication, Engineer must communicate with Conductor, and crew must inspect indicated door to ensure it is closed before authorizing Engineer to place "Doors Closed and Locked" switch in the "Bypass" position. The Engineer must notify the Dispatcher when the "Doors Closed and Locked" switch is placed in the "Bypass" position, and again when the "Doors Closed and Locked" switch is restored to the "Normal" position.

If the malfunctioning door is not closing, it must be secured in the closed position prior to movement. The train will then use the procedure outlined in paragraph **4(b)** above when departing each station. Once underway, the crew can attempt to clear the door malfunction, or manually secure the door if malfunction cannot be corrected. Status of the malfunctioning door can be verified from the MFD screen in the Café Car crew office. If the malfunction has been cleared, the Engineer must be notified to place the "Doors Closed and Locked" switch in the "Normal" position. If traction power is lost, Engineer must again be notified to place "Doors Closed and Locked" switch in the "Bypass" position, and door problem diagnosed at the next station stop.

If, after closing all doors at the next station stop, the door continues to malfunction (preventing traction power from being developed), crew members must manually secure the door, then use the associated Door Control Station to bypass the door by placing the "DCS" key switch in the "Isolate" (ISOL) position.

INDEX TO SYSTEM SPECIAL INSTRUCTIONS

Subject	Page
ACSES Rules	338-346
Alcohol and Drug Testing	260
Block Training Class Attendance	253
Bulletin Order	267
Cab Signal System	336-338
Close Clearance	310
Conductors and Assistant Conductors	254, 359
Crew Resource Management	275
Defect Detectors	313-316
Electrical Operation	310-313, 364
Emergency Situations	257-260
Engineers	254, 360-361
Form D Rules	330-333
Form D Control System	336
Foul Time	328-329
Freight Train Operation	281, 283-286
Fusees	277
Hazardous Materials	310
High Speed Trainset & HHP-8 Operation	362-373
Highway Crossings at Grade	325-326
Interlocking Rules	347-349
Job Briefing	272-275
Out-of-Service Tracks	320-324
Passenger & Freight Train Operation	283-286
Passenger Train Operation	279-281, 283-286
Physical Characteristics	255-256
Physical Examinations	265
Radios, Telephones, and Electronic Devices	349-355
Shoving or Backing Movements	318-319
Speeds:	
Engines & Equipment	289-304
Special Maximum Speeds	287-288
Speed Table	287
Standard Time	272
Telephone Numbers	350-353
Temporary Speed Restrictions	269-271, 333-334
Track Car Rules	356-359



**NATIONAL RAILROAD PASSENGER CORPORATION
NORTHEAST CORRIDOR
GENERAL ORDER NO. 601
Effective 12:01 A.M., Monday, February 22, 2016**

1) Timetable Authority

This General Order contains Northeast Corridor (NEC) Employee Timetable No. 6, which **replaces** NEC Timetable No. 5 in its entirety. Employees must examine each page of their copy of Timetable No. 6 to see that it is complete, and the pages are in proper order. Employees must then review any changes which may affect their duties.

Employees must transfer the information contained on the “Employee Physical Characteristics Qualification Record/Employee Physical Examination Record” pages to this Timetable.

This GO also contains a reprint of the “Northeast Corridor Timetable Appendix A” pages (yellow), revised and reissued October 29, 2007, these pages are to be placed at the end of Timetable No. 5.

The following items contain a brief explanation of the changes made in this Employee Timetable, as well as recent physical characteristics changes.

2) Title Page

General Order No. 601 in effect.

3) Summary of Train Schedule Changes

None. Due to the ongoing track work trains will continue to be governed by the schedules published in the Bulletin Orders.

4) Letters and Characters Used in Train Schedules

Code “LX” is added to Letters and Characters “Note” at the bottom of page 4.

5) Letters and Symbols Used in the Station Pages and Special Instructions

“WILD” and “RA WILD” are added to the list of Letters and Symbols used in the Station Pages and Special Instructions on page 102.

MAIN LINE—NEW HAVEN TO BOSTON

6) Station Page

Notes added for Interlockings equipped with movable point frogs or slip switches.

7) METRO-NORTH RAILROAD GENERAL ORDERS AND BULLETIN ORDERS

New SI 1-B3 added.

8) Providence Yard: Engine Storage

Track number changed to 11 in SI 36-B2.

9) Passenger Trains and Freight Trains Maximum Speeds

P32AC-DM, LDSL Baggage Cars added to Train Type “B” in SI 37-B1.

10) Engine and Equipment Restrictions

Equipment dimension codes revised between New Haven and Davisville.

11) Maximum Speeds – Other Tracks

Locations and Tracks revised for Parcel G in SI 37-B3.

12) Cars Exceeding 263,000 Pounds

Restriction added to SI 41-B2 for UgBr MP 146.39.

13) Groton Interlocking Derail

Interlocked, facing-point, split point derail for eastward movements on the east leg of the Wye at Groton is in service 227 feet west of the switch to track 1.

14) Wheel Impact Load Detectors

New SI 72-B2 added to list wheel impact load detector locations.

15) Fouling Point of a Track

New SI 101-B2 added.

16) Dispatchers: Assigned Territories

SI 900-B1 revised in its entirety.

DORCHESTER BRANCH

17) Southampton Street Yard: Entering and Leaving

SI 104-D3 is revised in its entirety.

MILL RIVER TO SPRINGFIELD

18) Speed Enforcement Approaching Curves / Permanent Speeds

Wayside and/or Cab Signal changes have been made to enforce speeds approaching the following locations:

Northbound: curves at MP 59.1 & MP 59.6 on No. 1 and 2 tracks, curves at MP 49.3 & MP 50.5 on the single track, 20 MPH permanent speed between MP 36 & Hart on the Single Track,

Southbound: curves at MP 50.5 & MP 49.3 on the single track; 20 MPH permanent speed between Hart and MP 36 on the Single Track

19) Hand Operated Switches Removed

The Gallo Wine switch on Track 2 at MP 6 has been permanently removed.

20) Wheel Impact Load Detectors

New SI 72-M2 added to list wheel impact load detector location(s).

21) Switches Equipped with Electric Locks Added or Removed

Hand-operated switches converted to electric lock and are added to SI 104-M2: MP 32.4 & MP 33.2 on No. 2 Track, MP 36.2 on the Single Track.

Switches removed from SI 104-M2: MP 9.9 Defco Ind., MP 14.4 to Colony Lumber & Ryerson Steel, MP 25.8 to ST RR.

22) Tracks and Switches out of service

Defco Ind. Sw MP 9.9 deleted from SI 132-M1.

23) Hart Interlocking

Hart interlocking sw (12) for movements to and from the Hartford Running Track has been moved 166 feet south of its former location. Color light interlocking signal (1N) for northward movement on the Single Track is relocated 355 feet south of former location. It is now located to the right and adjacent to the single track, 10 feet south of the Main and Albany Street Tunnel.

MAIN LINE - HAROLD TO CP216

24) Station Page

Note added for Interlockings equipped with movable point frogs.

25) Signal Rules and Current of Traffic

In SI 240-H1, ACSES Rules in service west limits Gate to west limits CP 216.

26) Cars Exceeding 263,000 Pounds

New SI 41-H1 added.

27) Catenary Dead Sections

ACS-64 engines added to the list of electric engines in SI 47-H1.

28) ACSES Territory, ACSES Positive Stop Data Radio Release

New Special Instructions 580-H1 and 583-H1 added.

MAIN LINE - NEW YORK TO HOFFMANS

29) Station Page

CP 138, MP 138.6, and note for Int equipped with slip switches added.

- ▶ Northbound CP signals on No.1 and No.2 trks are 3264 feet north of MP 138. Southbound CP signals on No.1 and No.2 trks are 2016 feet south of MP 139. Clear to the Next Interlocking signals (Rule 280a): in service northbound at CP 138, not in service southbound at CP 141.

CP 141 (Interlocking) MP 141.4, replaces CP 141 (Control Point) MP 141.1.

- ▶ Former Freight Bypass / Rensselaer Industrial Track is renamed No. 6 Track between a new sign at MP 141.45, 596 feet east of the new westbound home signal for CP 141 and the hand operated switch for movement to track No. 2 at MP 142.2. NORAC Rule 98 remains in effect on Track No. 6, except Interlocking rules are in effect within the limits of CP 141.
- ▶ Westbound color light home signals for No. 1 track (1W) and No. 2 track (2W) are in service on a cantilever mast 1760 feet west of the former CP 141 control point signals. New westbound low color light home signal for track No. 6 (6W) is located 1023 feet west of the new westbound signals for tracks 1 and 2.
- ▶ Eastbound low color light home signals on track No. 6 (6E) and No. 2 (2E) are 3033 feet west of the former CP 141 control point signals. Eastbound low color light home signals on track No. 1 (1E) and No. 3 (3E) are 3205 feet west of former CP 141 control point signals. The eastbound home signals on all tracks in CP 141 are signals.
- ▶ Interlocked crossover in service for westward moves from Track 1 to Track 2. The facing points on Track 1 are 50 feet west of the westbound home signal and the trailing points on track 2 are 820 feet east of the eastbound home signal.
- ▶ Interlocked crossover in service in CP 141 for westward moves from Track 2 to Track 1. The facing points on Track 2 are located 549 feet west of the westbound home signal, and the trailing points on track 1 are 498 feet east

of the eastbound home signal CP 141.

- ▶ Interlocked facing point turnout in service for westward moves from Track 1 to Track 3. The facing points on Track 1 are 1111 feet west of the westbound home signal.
- ▶ Interlocked crossover in service for westward moves from Track 2 to Track 6. The facing points on Track 2 are 1068 feet west of the westbound home signal and the trailing points on track 6 are 25 feet east of the eastbound home signal.
- ▶ Clear to Next Interlocking Signals, Rule 280a in service at the eastbound home signals on tracks 1, 2 and 3.

Dispatching territories updated.

30) Signal Rules and Current of Traffic

In SI 240-U1: Signal rules revised CP 138 to CP 144. Fixed ABS signals removed from service on Trks 1 & 2 from CP 138 to CP 141. Rule 562 in service between CP 138 & CP 141.

31) Passenger Trains Maximum Speeds and Speed Restrictions

In SI 37-U1, locations and Psgr speeds revised MP 102.6 to MP 114.1; Psgr & Frt locations, tracks, and speeds revised MP 141.1 to MP 142.4.

32) CP 143 Switch Removed and Signal Relocation

Switch (No. 1) for moves between the Main Track and Yard Track 3 is removed. Color light Int sig (5W) governing westward moves on Main Track relocated 290 feet west and is a dwarf color light signal. Color light Int sig (5EB) governing eastward moves from Yard Track 3 to Main Track is removed.

33) Train Inspection Detector Removed from Service

In SI 72-U1, RA HBD-DED at MP 121.5 is removed from service and deleted.

34) Switches Equipped with Electric Locks

Switch at MP 151.5 to Colonie removed, and deleted from SI 104-U1.

35) Tracks and Switches Out of Service

Deleted from SI 132-U1: River Track MP 113.5 returned to service; switches at Central Warehouse MP 143.4 & Colonie switch MP 151.5 removed from track.

36) Highway Rail Crossings at Grade Equipped with Automatic Warning Devices

SI 138-U1: Title changed from "Highway Rail Crossings at Grade Equipped with Automatic Warning Devices" to "Public Crossings at Grade", and Ice House Rd., MP 122.25 added.

37) "NO FIXED ABS" Signs at Entrance to Rule 562 Territory

New SI 562-U1 added.

38) Dispatchers: Assigned Territories

Hudson North Dispatcher added. Instruction revised in its entirety.

NEW YORK TERMINAL DISTRICT

39) Station Page

Notes added for Interlockings equipped with movable point frogs or slip switches.

- 40) Capitoline Control Cars: Speed Restriction through East River Tunnel**
Speed restriction added to SI 37-T1 for Capitoline Control Cars, series 9632 through 9651 and conference car 9800 through East River Tunnels.
- 41) Superintendent - Train Operations Notices**
SI 1-T1, Superintendent - Train Operations Notices, deleted.
- 42) Engine Whistle or Horn: PSNY, A, JO, C, & KN Interlockings**
"A" Interlocking added to the list of locations in SI 19-T1.
- 43) Tracks and Switches Out of Service**
Numbers 4 & 5 Lead Tracks added to SI 132-T1.
- 44) Harold Interlocking Cut-over**
- A. No. 1 Track (Line 1):** Mast mounted position light Int home signal (850e) governing eastward movement on No.1 track (Line 1), located 2200 feet east of MP 3 (former F interlocking station), replaced by new New high color light Int home signal, now designated 48e, on a signal bridge at the same location.
 - B. No. 3 Track (Line 3):** Pedestal style position light Int home signal (848e) governing eastward moves on No. 3 track (Line 3), 1915 feet east of MP 3 (former F interlocking station), is replaced by new high color light Int home signal, now designated 47e, located on a signal bridge at the same location.
 - C. Main Line 2:** Pedestal position light Int block signal (844w) governing westward movement on Main Line 2 track 355 feet east of MP 3.7 (former Harold Int station), is replaced by new mast mounted high color light Int block signal, now designated as 47w signal, at the same location.
 - D. LIC Eastward Psgr Track:** Pedestal position light Int sig (846e) governing eastward moves on LIC Eastward Passenger track located 1915 feet east of MP 3 (former F Int station) is replaced by new high color light Int signal, now designated as 46e, located on a signal bridge at the same location.
 - E. LIC Eastward Psgr Track:** Mast mounted position light Int signal (846w) governing westward moves on LIC Eastward Passenger Track located at MP 3.7 (Former Harold Int station) is removed. New mast mounted high color light Int signal, designated 46w, governing westward movement on the LIC Eastward Passenger Track, and diverting moves to No. 1 (Line 1) and No. 3 (Line 3) tracks, located 355 feet east of MP 3.7 is in service.
 - F. LIC Eastward Psgr Track-Long Island Freight Track:** New mast mounted color light Int signal designated as 25ec is located within the crossover 355 feet east of MP 3.7, for eastward moves diverting from the LIC Eastward Psgr track to the Long Island Freight track, or towards Amtrak No. 2 track.
 - G. Long Island Freight Track- LIC Eastward Passenger Track:** New mast mounted high color light Int signal designated as 45wc is located within the crossover 355 feet east of MP 3.7 for westward moves when diverting from the Long Island Freight track to the LIC Eastward Psgr track or to No. 1 (Line 1) and No. 3 (Line 3) tracks.
 - H. Long Island Freight Track-Long Island Westward Passenger Track:**
New facing point interlocked crossover (821) in service 580 feet east of MP 3.7 (former Harold interlocking station) on Long Island Freight track for westward movement to the Long Island City Westward Psgr track. Switch is equipped for AC and DC operation.
 - I. Westward Passenger Track / Mainline No. 1 Track :**
New high color light interlocking signal (No. 34w signal) located on a new signal bridge 175 feet east of MP 3.7 (former Harold Interlocking Station) governing westward movement on Mainline No. 1 track.
New high color light signal (No. 24e signal) located on a new signal bridge 175 feet east of MP 3.7 (former Harold Interlocking Station) governing eastward

movement on Mainline No. 1 track.

High position light automatic signal No. 15 located 450 feet west of MP 3.7 (former Harold Interlocking Station) governing westward movement on the Long Island City Westward Passenger Track is out of service and removed.

High position light interlocking signal (No. 812e signal) 450 feet west of MP 3.7 (former Harold Interlocking Station) governing eastward movement on Long Island City Westward Passenger track is out of service and removed.

New high color light automatic signal No. 13-4 located on a new signal bridge located 1150 west of MP 3.7 (former Harold Interlocking Station) governing westward movement on the Long Island City Westward Passenger Track.

New high color light interlocking signal (No. 34ea signal) located on a new signal bridge 1150 feet west of MP 3.7 (former Harold Interlocking Station) governing eastward movement on the Long Island City Westward Passenger Track.

New facing point interlocked turnout (No. 3164 switch) on Mainline No. 1 track for westward movement to Long Island Freight Track 460 feet west of MP 3.7 (former Harold Interlocking Station) is equipped with moveable point frog and is in service for AC and DC electrical operation.

- J. Long Island City Westward Psgr Track-Long Island Mainline 3 (Line 2):** Facing point interlocked crossover equipped for AC/DC operation (3134) in service on Long Island City Westward Psgr trk 115 feet east of MP 3.7 (former Harold Int station) for westward moves to Long Island Mainline 3 (Line 2).

- K. Port Washington No. 1 Track / No. 4 Track (Line 4):**

New high color light interlocking signal (32w signal) located on new signal bridge 175 feet east of MP 3.7 (former Harold Interlocking Station) governing westward movement on Port Washington No. 1 track.

New high color light interlocking signal (22e signal) located on new signal bridge 175 feet east of MP 3.7 (former Harold Interlocking Station) governing eastward movement on Port Washington No.1 track.

High position light automatic block signal No. E37 located 450 west of MP 3.7 (former Harold Interlocking Station) governing westward movement on No.4 track (Line 4) is out of service and removed.

High position light interlocking signal (No. 808e signal) located 450 west of MP 3.7 (former Harold Interlocking Station) governing eastward movement on Port Washington No.1 track is out of service and removed. This was previously Harold interlocking's eastbound home signal on Port Washington No. 1 track.

New high color light automatic block signal No. E-35-4 governing westward movement on No. 4 track (Line 4) located on a new signal bridge 1150 west of MP 3.7 (former Harold Interlocking Station).

New high color light interlocking signal (No. 32e signal) governing eastward movement on Port Washington No. 1 track located on a new signal bridge 1150 west of MP 3.7 (former Harold Interlocking Station). This is now Harold interlocking's eastbound home signal on Port Washington No. 1 track.

- L. Mainline No. 3 Track / No. 2 Track (Line 2):**

New high color light interlocking signal (33w signal) located on a new signal bridge located 175 feet east of MP 3.7 (former Harold Interlocking Station) governing westward movement on Mainline No. 3 track.

New high color light interlocking signal (No. 23e signal) located on a new signal bridge located 175 feet east of MP 3.7 (former Harold Interlocking Station) governing eastward movement on Mainline No. 3 track is in service.

High position light automatic block signal No. E37 located 450 feet west of MP 3.7 (former Harold Interlocking Station) governing westward movement on No. 2 track (Line 2) is out of service and removed in its entirety.

High position light interlocking signal (No. 814e) located 450 feet west of MP 3.7 (former Harold Interlocking Station) governing eastward moves on Mainline No. 3 track is out of service and removed in its entirety. This was previously Harold interlocking's eastbound home signal on Mainline No. 3 track.

New high color light automatic block signal No. E35-2 located on a new signal bridge located 1150 west of MP 3.7 (former Harold Interlocking Station) governing westward movement on No. 2 track (Line 2) is in service.

New high color light interlocking signal (No. 33e) located on a new signal bridge located 450 west of MP 3.7 (former Harold Interlocking Station) governing eastward movement on Mainline 3 track is in service. This is now Harold interlocking's eastbound home signal on Mainline No. 3 track.

M. Long Island Freight Track

That portion of the Long Island Freight track located 395 feet east of MP 3.7 (former Harold Interlocking Station) and 1245 feet west thereof is out of service and removed in its entirety.

The east end of the facing point interlocked crossover (No. 4165 switch) located 395 feet east of MP 3.7 (former Harold Interlocking Station) has been removed. The west end of this crossover remains in service and equipped for AC and DC electrical operations as a trailing point interlocked turnout for westward movements to the Long Island City Eastward Passenger Track.

High position light automatic signal No. M15 located 450 west of MP 3.7 (former Harold Interlocking Station) governing westward movement on Long Island Freight Track is out of service and removed in its entirety.

New high color light automatic signal No. M13 located on a new signal bridge located 1150 west of MP 3.7 (former Harold Interlocking Station) governing westward movement on the Long Island Freight Track is in service.

High position light interlocking signal (No. 818e sig.) located 450 west of MP 3.7 (former Harold Interlocking Station) governing eastward movement on Long Island Freight Track is out of service and removed in its entirety.

New high color light signal (No. 34ec signal) governing eastward movement on the Long Island Freight track to Mainline No. 1 track located on a new signal bridge located 1150 west of MP 3.7 (former Harold Interlocking Station) is in service.

MAIN LINE – NEW YORK TO PHILADELPHIA

45) Station Page

Delco Int MP 33.6, Adams Int MP 37.2, and CP Clark MP 48.7 added. Notes added for Interlockings equipped with movable point frogs and slip switches.

- 46) Dock Interlocking:** Position light sig (78R) for westward movement on No.4 trk at the east end Dock Int is replaced by new color position light signal 150 feet east of the former location. The new sig is 1524 feet west of Dock's home signal (70R) on track No.3, 952 ft. west of the crossover (71) from No. 3 to No. 4 track.

47) Lane Interlocking:

The No. 54 switch at Lane Interlocking, located on No. 4 Trk for westward movement to Durant Yard, is out of service and has been removed.

Signal No. 5AW and Signal No. 5E located approximately 750 feet west of MP 12.0 governing eastward and westward movements on No. 5 Trk to and from Durant Yard are out of service and removed.

48) Union Interlocking:

Facing point interlocked turn out (56) at MP20 on track B for eastward moves to Virginia Barrel Industrial Track is removed. Low interlocked position light sig (6w) for westward moves from Virginia Barrel Industrial Track to track B is removed.

49) Speed Enforcement Approaching Curves

Wayside and/or Cab Signal changes have been made to enforce speeds approaching the following locations:

Eastbound and westbound: curve west of Lincoln on No. 2 and No. 3 Tracks; curves at MP 74 & 75 west of Grundy on No. 2 and No. 3 Tracks; 50 MPH curve east of Shore on Nos. 1, 2, 3, 4 Tracks.

Westbound: curve between Girard Ave UgBr and Zoo Int Station on Nos. 1, 2, 3 & 4 tracks; curves between Girard and Penn on No.4 Track and Girard and Zoo on No. 3 Suburban track.

50) Station Page

Delco Int., Adams Int., CP Clark, and new notes 15 and 16 added.

51) Signal Rules and Current of Traffic: County to Ham

Note for ACSES above the table in SI 240-N1 is revised. Signal rules between County and Ham revised and Notes 6 & 7 deleted.

52) County Interlocking MP 32.8

Clear to the Next Interlocking signals in service for westbound moves.

53) Delco Interlocking MP 33.6

Delco Int. in service: Eastbound home signals on No.3 and No.4 trks 1290 feet east of MP 34. Westbound home signals on No.3 and No.4 tracks 2547 feet west of MP 33. New interlocked crossover No.43 is in service for westward movement from No. 3 Trk to No. 4 Trk. The facing points of crossover on No. 3 Trk are located 383 feet west of the westbound home signal No. 3W, and the trailing points on No. 4 Trk are located 240 feet east of the eastbound home signal No. 4E. Clear to Next Interlocking Signals: in service for westbound moves on trks 3 and 4; not in service for eastbound moves.

54) Adams Interlocking MP 37.2

Adams Int. In service: Eastbound home signals on No.1 and No.2 trks 3762 feet east of MP 38. Westbound home signals on No.1 and No.2 trks 140 feet west of MP 37. New interlocked crossover (12) equipped with movable point frog in service: Facing points on Track 1 are 54 feet east of the eastbound home signal; trailing points on Track 2 are located 454 feet west of the westbound home signal. Clear to Next Interlocking Signals in service for eastbound and westbound moves on No. 1 & No. 2 trks.

55) Midway MP 41.3

Clear to the Next Interlocking signals: in service for eastbound and westbound movements on all tracks.

56) CP Clark MP 48.7

Eastbound and westbound controlled signals in service on No.1, 2, 3, & 4 tracks located on the same signal bridge as former westbound automatic signals 487. Clear to Next Interlocking Signals in service for eastbound moves on all tracks.

57) Ham MP 55.7

Clear to Next Interlocking Signals not in service.

58) Superintendent - Train Operations Notices

SI 1-N2, Superintendent - Train Operations Notices, deleted.

59) Passenger Trains and Freight Trains Maximum Speeds and Speed Restrictions

- P32AC-DM, LDSL Baggage Cars added to Train Type "B" in SI 37-N1.
- Train Type "A" speeds changed between Hunter and Elmora on Tracks 2&3.
- Train Type "E" Speeds changed between West end Passaic River Br & Hunter.

60) Engine and Equipment Restrictions

Equipment dimension codes in SI 40-N1 revised between Linclon and Morris on No. 1 and No. 4 Tracks.

61) Train Inspection Detectors

Detector at MP 29.7 modified and note 1 added to SI 72-N1.

62) Wheel Impact Load Detectors

New SI 72-N2 added to list wheel impact load detector locations.

63) Switches Equipped with Electric Locks

Durant Yard, Adams Siding, Deans Siding and new note 2 (including Dspr procedures) added.

64) “No Fixed ABS” Signs at Entrance to Rule 562 Territory

Fixed ABS signals removed from service eastbound and westbound on: all trks between County and Midway; on No. 1 and No. 4 Trks between Midway & Ham. Ham, Midway, CP Clark & County added to SI 562-N2.

65) ACSES Rules in Effect for All Amtrak Trains

SI 580-S1 is revised in its entirety.

66) ACSES Positive Stop Radio Release

SI 583-N1 is revised in its entirety.

67) ACSES Operation with Failed Cab Signals

New SI 585-N1 added.

MAIN LINE - PHILADELPHIA TO WASHINGTON

68) Station Page

Moore and Lamokin St. revised; Delmarva Secondary Track at Davis renamed Reybold Branch. Notes added for Interlockings equipped with movable point frogs or slip switches.

69) Passenger Trains and Freight Trains Maximum Speeds and Speed Restrictions

- P32AC-DM, LDSL Baggage Cars added to Train Type “B” in SI 37-P1.
- Speed for Train Types “A”, “B”, “C”, and “D” revised between South end Susquehanna River Br and Gunpow.

70) Wheel Impact Load Detectors

New SI 72-P2 added to list wheel impact load detector locations.

71) Switches Equipped with Electric Locks

Switches at MP 100.2 and MP 101.7, and note 5 deleted from SI 104-P2.

72) Penn Coach Yard

Fixed derail in service on 37 track 50 feet south of the 37 car shop divider switch.

73) Speed Enforcement Approaching Curves

Wayside and/or Cab Signal changes have been made to enforce speeds approaching the following locations:

Northbound: curves between Phil and Penn Interlockings on Nos. 2 & 3 tracks; first curve north of Frederick Road, the first curve south of Bridge, and the curve at Fulton on Nos. 2 & 3 tracks.

Southbound: curve north of Wilmington on Nos. 2 & 3 tracks; reverse curves at Bay.

74) Signal Rules and Current of Traffic

Note for ACSES above the table in SI 240-P1 is revised. Signal rules between Ragan and Prince revised and Note 16 deleted.

75) Davis Interlocking

Southbound home signal on the NS Reybold Branch (former Delmarva Secondary Track) (8S) is relocated 75 feet south of its former location.

76) Yard Interlocking

Southbound home signal (9S) governing southbound movements from NS B&O track relocated 189 ft. north from former location.

77) Testing Sections

In SI 551-P1, NS Delmarva Secondary Track renamed Reybold Branch.

78) ACSES Rules in Effect for all Amtrak Trains

SI 580-P1 is revised in its entirety.

WASHINGTON TERMINAL

79) Station Page

Note added for Interlockings equipped with slip switches.

80) First Street Tunnel

Last paragraph added to SI F-W1.

81) Engine and Equipment Restrictions

New note "b" added to Track Nos. 22 to 30 in SI 40-W1.

MAIN LINE - PHILADELPHIA TO HARRISBURG

82) Station Page

Notes added for Interlockings equipped with movable point frogs or slip switches.

83) Speed Enforcement Approaching Curves

Wayside and/or Cab Signal changes have been made to enforce speeds approaching the following locations:

Westbound: 1st and 2nd curves west of automatic signal 295 on Track 4

Eastbound: curve east of Berwyn on Track 2, 1st and 2nd curves east of Downs on Track 1

Eastbound and Westbound: curve east of Berwyn on Track 3, curve west of MP 47 on Tracks 1 and 4, curves at Gap on Tracks 1 and 4, curves west of MP 60 and west of MP 61 on Tracks 1 and 4, curve west of Middletown on Tracks 1 and 2

84) Passenger Trains and Freight Trains Maximum Speeds and Speed Restrictions

- Third paragraph above the table in SI 37-G1 added.
- P32AC-DM, LDSL Baggage Cars added to Train Type "B" in SI 37-G1.
- Speed for Train Types "A", "B", "C", and "D" revised within Bryn Mawr Int; between west limits of Lititz and MP 84.

85) Engine and Equipment Restrictions

New note "b" added to SI 40-G1 for SEPTA Eng 70 restriction in Overbrook Int.

86) Public Road Crossings at Grade

Eby Cheques and New Comers Road Crossings permanently removed. SI 138-G1 and 138-G2 deleted.

87) State Interlocking

Switches: No. 53, 69, 73, 75, 77 Switches have been permanently removed from service. No. 65 turnout for westbound movement from No. 10X track diverting to No. 8 track has been relocated. The facing points of the switch on 10X track are 7 feet west of westbound signal No. 56L. The normal position (straight move) for the No. 65 switch is lined for movement from 10X to No. 9 track (former Pit Track). No. 95 turnout for westbound movement from No. 2 track to No. 10X track has been relocated. The facing points on No. 2 track are 602 feet west of westbound signal No. 100L. No. 101 crossover for westbound movement from No. 1 track to No. 9X track is relocated 150 feet east of its original location. The facing points of the crossover on No. 1 track are located 31 feet west of the westbound home signal 102L, and the trailing points on No. 2 track are located 318 feet east of the eastbound 100R signal.

Signals: The No. 56L signal governing westbound movements from No. 10X track to No. 9 track (former Pit Track) has been relocated. It is 249 feet west of the No. 95 turnout. The No. 76L signal governing westbound movements from No. 9X track to No. 7 track has been relocated. It is 959 feet west of the No. 100L signal (the first westbound signal in advance of the No. 76L). The No. 98R signal governing eastbound movements from No. 10X track to No. 1 or 2 track has been relocated. It is 393 feet east of the No. 56R signal (the first eastbound signal on No. 8 track in advance of the No. 98R). The No. 100R signal governing eastbound movements from No. 9X track to No. 1 or 2 track has been relocated. It is 452 feet east of the No. 58R signal (the first eastbound signal in advance of the No. 100R). **Tracks:** 15 Spur Track has been permanently removed from service. The Pit Track has been renamed No. 9 track

Catenary: The catenary has been removed on the western portion of No. 8 track from 1455 feet west of the facing points of No. 65 Switch (turnout to 10X Track) to the facing points of No. 78 Switch (turnout to 7 Track). New AC Motor Stop Sign is located in catenary 1440 feet west of the facing points of No. 65 Switch.

88) Dispatchers: Assigned Territories

Table in 900-G1 revised in its entirety.

36TH STREET CONNECTION

89) Station Page

Note added for Interlockings equipped with slip switches.

PHYSICAL CHARACTERISTICS CHANGES MULTIPLE LINES

- 90) New "Approach Permanent Speed Limits Signs" (NORAC Rule 296) installed on catenary poles throughout the NEC.

MULTIPLE LINE SPECIFIC SPECIAL INSTRUCTIONS

<u>Instruction</u>	<u>Brief Description of Change</u>
91) Each Line's Special Instruction "40-x1"	The first sentence of Each Line's Special Instruction "40-x1" has been changed to indicate that the dimension code specifies maximum height of equipment that may be operated.

SYSTEM SPECIAL INSTRUCTIONS

92) The following Special Instructions have been deleted, revised or added.

Number Brief Description of Change

A-S4	Books in effect updated
F-S2	New instruction
F-S3	Former SI F-S2 renumbered
Q-S2	Revised in its entirety.
1-S2	Tables in items 2 and 4 revised Items 3.E and 3.F deleted
4-S1	Item 5, phone No.s revised; Sunnysided job briefing location changed.
35-S1	New paragraph "B" added
36-S8	ACS-64s added
36-S9	Instruction Deleted (included in AMT-3 3.5.12), & 36-S10 renumbered
36-S10	New Instruction added to revise AMT-3 equipment tables.
37-S5	Various eng.s, cars, SI references & notes added, revised or deleted.
41-S5	Revised in its entirety
41-S7	Revised to include AMTK 15907
47-S2	MRS Line and No. 3 Trk at Stony added to list of exceptions
47-S7	ACS-64 engines added
47-S8	ACS-64 engines added
47-S10	New instruction
72-S8	Table of wheel impact load detector locations moved to relevant line SIs, Radio Alarm Wheel Impact Load Detector instructions added.
72-S9	ACS-64 engines added
80-S1	List of interlockings equipped with movable point frogs or slip switches moved to notes of each station page.
100-S1	New instruction; Includes info. from SI 100-A1, which is deleted
131-S1	Sections 3 and 4 revised
133-S1	CSXT Inspection Cars added to exceptions
133-S7	New instruction
165-S4	Contact No. changed for Springfield Ticket Office. Note 8 deleted & Note 16 renumbered 8. Instructions for Eastward, Northward & Westward Trains at New Haven, & Eastward Trains at NY-TOC revised.
580-S2	NYS Line added
581-S2	List of Train Types added
581-S3	ACS-64 engines added
601-S1	Revised in its entirety
714-S1	Hudson North Dspr added
815-S3	CSXT Geometry Inspection Vehicles added

HIGH SPEED TRAINSET & HHP-8 SPECIAL INSTRUCTIONS

93) The following Special Instructions have been deleted, revised or added.

Number Brief Description of Change

72-A3	Sections A and B revised in their entirety
100-A1	Deleted
117-A1	Deleted (Information contained in SI 36-S8)

94) General Order - New pages: 1- 4, 101- 374

Employees must examine their copy of General Order 601 to ensure that it is complete, then review the revised and new instructions.

DJ Stadtler
Executive Vice President Operations