

DEEP AND SURFACE STRUCTURE CONSTRAINTS IN SYNTAX

by

David M. Perlmutter

Submitted to the Department of Modern Languages and Linguistics
on August 19, 1968 in partial fulfillment of the requirements for the
degree of Doctor of Philosophy.

ABSTRACT

This dissertation is concerned with the problem of filtering in generative grammar - the problem of generalized phrase markers generated by the base component which underlie no well-formed sentences, and the kinds of grammatical devices that are needed to characterize such sentences as ungrammatical. It is shown here that grammars must include deep structure constraints or well-formedness conditions on the input to the transformational component and surface structure constraints or well-formedness conditions on the output of the transformational component. The implications of the availability of these filtering devices for the power of grammars are briefly discussed.

Thesis Supervisor: Noam Chomsky
Title: Ward Professor of Linguistics

ACKNOWLEDGEMENTS

I owe a great deal to many people who have helped me in many different ways in my graduate education at M.I.T. and in the work that led to this dissertation. Even though I cannot mention them all individually, I would like to single out a few to whom I am especially indebted and express my gratitude.

The faculty of the Department of Modern Languages and Linguistics at M.I.T. admitted me to the graduate program in linguistics even though I was a bad risk with two previous attempts at graduate school behind me. I am grateful to them for giving me the privilege of studying with them, answering my many immature questions, and encouraging me in my first uncertain attempts to do linguistics. I have learned a great deal from Edward Klima, Hubert Matthews, Paul Kiparsky, and Barbara Hall Partee. To four members of the Department I owe a special debt. This thesis would have of course been impossible without the staggering theoretical contributions of Noam Chomsky. He also gave generously of his time in discussing this work with me. But most of all I am grateful to him for essentially creating a field in which I could find my place after what seemed like many years of aimless wandering. Morris Halle, by putting the goal of genuine understanding above all else, conveyed to me the all-important distinction between a proposal that works and an explanation of phenomena, while administering the graduate program in a way that gave us all an environment uniquely conducive to learning and discovery. Paul Postal blazed trails in the wilderness of syntax and thereby gave the field a promise and a vitality

that I could not resist. I will not forget his patience and understanding in guiding my first groping attempts at understanding. John Ross has taught me a great deal about syntax, both through his own work and in discussions of the work of others. He has taken a personal interest in this thesis at every stage of its development, and contributed to it, directly and indirectly, in many ways that defy acknowledgement.

Of the many friends and colleagues who have contributed to this thesis, I will mention just a few. It was Mayles Browne who pointed out to me the difficulty of handling the Serbo-Croatian data discussed in Chapter One by means of transformational blocking. His work on clitic placement in Serbo-Croatian led me to examine the analogous phenomena in Spanish; Chapter Four is the result of this study. Discussions with Jay Keyser have sharpened my thinking on many of the issues discussed here, and they led, in particular, to the discovery of crucial evidence for the surface structure constraint proposed in Chapter Five. Kenneth Hale has extended my linguistic horizon by contributing the insights born of his desire for explanation of data drawn from the myriad languages with which he is familiar. George Lakoff has given generously of his time in discussing a variety of linguistic problems and has helped to clarify my thinking on many of the issues discussed here. James Harris has been particularly helpful in the development of Chapter Four. I would also like to thank Stephen Anderson, Susumu Kuno, S.-Y. Kuroda, Brandon Qualls, and many other friends and colleagues for their perceptive comments and criticisms.

Fortunato Danón and Guillermo Segreda kindly consented to serve as native Spanish-speaking informants. They gave generously of their time, and without their help Chapter Four would have been impossible.

I would also like to thank Ljubivoje Acimović, Velimir Kuftinec, and Hastko Maglič, who were my informants for Serbo-Croatian.

I am grateful to Robert and Elizabeth Socolow for extending me their hospitality at their Long Island villa in July 1968, where parts of this thesis were actually written.

I would like to thank Elizabeth Metcalf for typing this thesis.

As a graduate student at M.I.T., I was supported for one year by a fellowship under the National Defense Education Act and for one year by a graduate fellowship in linguistics provided by the American Council of Learned Societies. I am also indebted to John Olney and the Systems Development Corporation of Santa Monica (California), where I was a summer student consultant during the summer of 1966. The final stages of the preparation of this thesis were accomplished while I was supported by grant No. GS-2005 from the National Science Foundation to Brandeis University.

Special mention must be made here of my students at Brandeis University. I owe them much, for I have learned a great deal from them, and they have helped in the writing of this thesis by serving as models of its prospective readership. But most important, they inherit the legacy of my indebtedness to my teachers, colleagues, and friends. Some of what I cannot repay them I can attempt to pass on to my own students.

TABLE OF CONTENTS

	<u>Page</u>
Abstract.....	1
Acknowledgements.....	2
Introduction.....	7
Footnotes to Introduction.....	11
 PART ONE - DEEP STRUCTURE	
Chapter One - Evidence for Deep Structure Constraints in Syntax.....	12
1.1 The unlike-subject constraint in English.....	15
1.2 The like-subject constraint in Serbo-Croatian.....	18
Footnotes to Chapter One.....	32
Chapter Two - The Like-Subject Constraint in English.....	38
2.0 Evidence that the like-subject constraint in English is a deep structure constraint.....	39
2.1 Apparent counter-examples to this claim.....	41
2.1.1 Passive cases.....	41
2.1.2 NP* cases.....	62
2.2 The verb <u>intend</u> and the putative universality of the like-subject constraint.....	82
2.3 A deep structure constraint on imperative sentences..	99
Footnotes to Chapter Two.....	102
Chapter Three - The Two Verbs 'Begin'.....	106
Footnotes to Chapter Three.....	119

PART TWO - SURFACE STRUCTURE

Chapter Four - Evidence for Surface Structure Constraints in Syntax: Object Pronouns in Spanish.....	126
4.0 Introduction.....	127
4.1 The spurious <u>se</u> rule.....	129
4.2 Ungrammatical sequences of object pronouns in surface structure.....	136
4.3 Developing a notation to state the constraint.....	153
4.4 Evidence that the constraint is statable only as a surface structure constraint.....	174
4.4.1 Evidence that the constraint can not be stated transformationally.....	175
4.4.2 Evidence that the constraint can not be stated by phrase structure rules in the base.....	181
4.5 Theoretical points.....	185
Footnotes to Chapter Four.....	192
Chapter Five-A Typological Difference Among Languages.....	202
Footnotes to Chapter Five.....	235
Epilogue - Filtering in Generative Grammar	240
Footnotes to Epilogue.....	259
Bibliography.....	261
Biographical Note.....	264

INTRODUCTION

In Aspects of the Theory of Syntax, Chomsky deals at length with the problem of strict subcategorizational and selectional restrictions and the means by which an explicit grammar should account for them. He also motivates the introduction of generalized phrase markers into linguistic theory and notes that some generalized phrase markers generated by the base component underlie no well-formed sentences. This would be the case, for example, in any sentence in which a relative clause does not contain a noun phrase identical to the antecedent of the relative clause. It is necessary for the grammar to characterize such sentences as ungrammatical. For this case, Chomsky proposes that the obligatory relative clause transformation, which requires identity between the antecedent and a noun phrase in the relative clause, will be unable to apply and will cause the derivation to 'block.' He proposes that the transformations perform a 'filtering function' in that, in the manner just described, they 'filter out' ill-formed sentences. A grammatical sentence is one which has passed through the transformational component with no such 'blockings' having taken place. In this theory, a transformational grammar pairs deep and surface structures, blocking certain derivations along the way. The notion 'deep structure' is itself derivative from this, the transformational rules acting as a 'filter' that permits only certain generalized phrase markers to qualify as deep structures.¹

This dissertation is concerned primarily with the problem of filtering in generative grammar - the problem of generalized phrase markers generated by the base component which underlie no well-formed sentences, and the kinds of grammatical devices that are needed to characterize such sentences as ungrammatical.

Part One of this dissertation is concerned with certain non-sentences which have ill-formed deep structures whose ill-formedness can not be characterized by means of the blocking of an obligatory transformation. In Chapters One and Two it is shown that there are certain verbs which require that the subject of a sentence embedded beneath them be identical to their own subject, and there are other verbs which require that the embedded subject be non-identical to their own subject. It is shown that these requirements must be satisfied prior to the operation of the transformational cycle. For this reason they are called deep structure constraints. They are well-formedness conditions on generalized phrase markers which apply prior to the application of transformations and 'filter out' certain generalized phrase markers generated by the base as ill-formed.²

In Chapter Three, the deep structure constraints motivated in the first two chapters are used to show that there are verbs which occur in deep structure both as transitive verbs which take object complements and as intransitive verbs which take abstract (sentential) subjects. The verb begin is used as an example of such a verb.

In Part Two, we return to the problem of how ungrammatical sentences are to be characterized as such by grammars. In Chapter Four it is shown that in order to characterize certain Spanish sentences as ungrammatical, it is necessary to impose a surface structure constraint which acts as a filter and rejects as ungrammatical any sentence which contains object pronouns that are not in the prescribed order. It happens that in certain cases where the surface structure that results from a particular deep structure is rejected as ungrammatical by the surface structure constraint, there is no way to actualize that deep

structure as a grammatical sentence. As a result, there are well-formed deep structures to which there corresponds no grammatical surface structure.

Chapter Five motivates a surface structure constraint in the grammars of French and English and contrasts them with languages which lack this constraint. It is suggested that languages differ typologically according to whether or not their grammars contain this surface structure constraint.

In sum, it is shown here that grammars must include deep structure constraints or well-formedness conditions on generalized phrase markers generated by the base component and surface structure constraints or well-formedness conditions on the output of the transformational component. This endows grammars with filtering devices at the levels of deep and surface structure in addition to the filtering function of transformations proposed in Aspects. The availability of so many filtering devices makes grammars too powerful and therefore weakens linguistic theory, unless the availability of these filtering devices is used to constrain grammars in ways that were not possible in earlier theory. In the Epilogue some tentative suggestions are put forth as to how the availability of surface structure constraints can contribute to the development of an evaluation measure for grammars which by its very nature constrains the range of grammars allowed by linguistic theory and enriches linguistic theory correspondingly.

Footnotes to Introduction

1. See Chomsky (1965), especially pp. 138-139.
2. The deep structure constraints discussed here are an outgrowth of concern with this problem by workers in the field such as Chomsky, Postal, and Lakoff. The contextual features proposed in Chomsky (1965) are essentially deep structure constraints. Postal pointed out the identity and non-identity requirements which I have called the like-subject constraint and the unlike-subject constraint, and suggested that they are predictable from semantic properties of the verbs in question. For further observations on this problem by Postal, see Postal (1967). Verb-verb constraints of various kinds have been pointed out by Chomsky, Postal, and Lakoff. The contribution of this dissertation to the developing study of deep structure constraints lies in the evidence that is presented to show that these constraints can not be stated transformationally, since they are not satisfied if one of the two subjects which must be identical or non-identical is a derived subject, but only if it is a subject in deep structure. As a result linguistic theory must include deep structure constraints which extend the notion of contextual features proposed in Chomsky (1965) to constraints which extend across sentence boundaries in generalized phrase markers and which require identity of noun phrases rather than particular values of strict subcategorizational or selectional features.

PART ONE

CHAPTER ONE

Evidence for Deep Structure Constraints in Syntax

1.0 In his study of complementation in English, Rosenbaum (1967) points out that in certain complement constructions there must be identity of the erasing and erased noun phrases defined by the identity erasure transformation (Equi-NP Deletion). This is the case with verbs like condescend, so that

(1) I condescended to commit myself.

is grammatical, but

(2) *I condescended for Bill to commit himself.

is not. In examples of transitive verb phrase complementation, the subject of the embedded sentence must be identical to the object of the matrix sentence.

(3) I persuaded Fred to commit himself.

(4) *I persuaded Fred for Roxanne to commit herself.

There are also cases in which the subject of the embedded sentence must be non-identical to the subject of the matrix sentence.

(5) I screamed for Clyde to commit himself.

(6) a. *I screamed for me to commit myself.

b. *I screamed to commit myself.

The question which concerns us here is one which lay beyond the scope of Rosenbaum's study - that of how such restrictions are to be stated in grammars.

The first attempt to state these restrictions precisely was made by Lakoff (1965). Lakoff took the proposal made by Chomsky (1965) that the blocking of an obligatory transformation 'filters out' ill-formed sentences as ungrammatical, and tried to extend it to account for the subject-subject restrictions in sentences like (1-6). In order to do this he proposed the notion of 'absolute exceptions' to transformational

rules, marking verbs like condescend and persuade as 'absolute exceptions' to the rule of Equi-NP Deletion. This meant that these verbs had to be marked in the lexicon as requiring:

- a) that the structural description of Equi-NP Deletion be met
- and
- b) that Equi-NP Deletion actually apply.

In Lakoff's framework, ordinary exceptions stipulate only that some rule must or must not apply, as in b) above. Absolute exceptions differ from them in that they have another condition such as a) above, stipulating that the structural description of some rule must or must not be met. Lakoff's motivation for this was to distinguish sentences like *(2), in which neither a) nor b) is satisfied, from sentences like

(7) *I condescended for me to commit myself.

in which only b) is violated. Lakoff also proposed treating verbs like scream as absolute exceptions, marking them in the lexicon as requiring:

- a) that the structural description of Equi-NP Deletion not be met
- and
- b) that Equi-NP Deletion not apply.

By marking condescend, persuade, and scream as absolute exceptions to the Equi-NP Deletion transformation, Lakoff was contending that the ungrammaticality of *(2), *(4), and *(6) represents some kind of transformational violation.

Lakoff's attempt to treat the data of (1-6) by means of absolute exceptions to the Equi-NP Deletion transformation was an attempt to use the transformational component to characterize sentences like *(2), *(4), and *(6) as ungrammatical. If one were to assume that all filtering in grammars must be accounted for transformationally,¹ one would be

driven to some such notion as absolute exceptions. Since in (1-6) we are dealing with a constraint between the subject of a sentence and the subject of a sentence embedded beneath it, the only transformation we could possibly make use of to characterize the relevant sentences as ungrammatical would be a transformation that looks at the two subjects. The only transformation that does this is Equi-NP Deletion. Lakoff's notion of absolute exceptions to Equi-NP Deletion, then, is a logical result of his attempt to account for the data transformationally.

It is the purpose of this chapter to show that the formalism proposed by Lakoff to handle (1-6) is inadequate, and that the attempt to account for such examples transformationally must therefore be abandoned. We conclude that it is necessary to use deep structure constraints whose domain extends across sentence boundaries in generalized phrase markers in order to characterize certain sentences as ungrammatical. The evidence for this claim is drawn from the unlike-subject constraint in English and the like-subject constraint in Serbo-Croatian.

1.1 The unlike-subject constraint in English.

At issue here is the question of how the ungrammaticality of sentences like *(6) is to be characterized. The proposal of Lakoff (1965) was to mark verbs like scream as absolute exceptions to the rule of Equi-NP Deletion. Using this formalism, a violation would be registered in sentences with scream in the event that the structural description of Equi-NP Deletion were met or in the event that the rule applied.

There is a very simple way to test the correctness of this solution. If it is correct and the unlike-subject constraint is transformational in nature, then the grammaticality of the resulting sentence will depend on whether or not the subject of the embedded sentence and the matrix subject are non-identical at the stage of derivations at which the Equi-NP Deletion transformation applies. If, on the other hand, we are dealing with a deep structure constraint, then it is the identity or non-identity of the two subjects before the application of any transformations that is relevant to the grammaticality or ungrammaticality of the resulting sentence. To decide between the two hypotheses, then, we must pick an example in which the embedded sentence no longer has the same subject when Equi-NP Deletion applies that it had in deep structure. One such example is:

(8) I screamed to be allowed to shave myself.

The deep structure of (8) is something like²

(9)

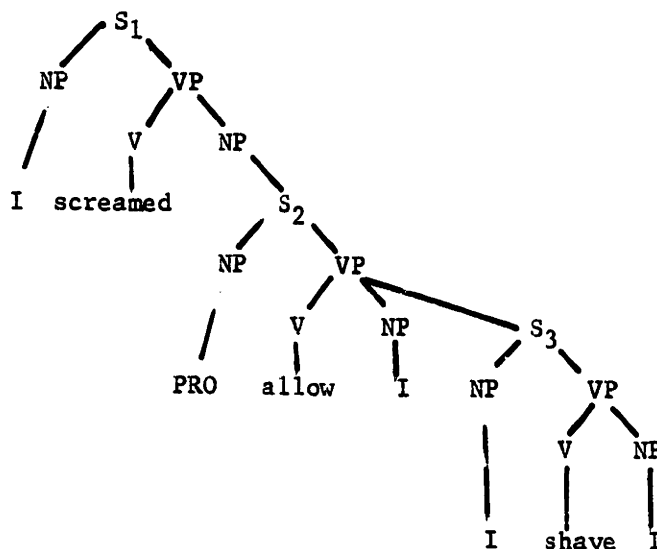

Reflexivization applies in S_3 on the first cycle, and on the second (S_2) cycle the subject of S_3 is deleted by Equi-NP Deletion and the passive transformation applies in S_2 , so that I becomes the derived subject of S_2 . After the second cycle, then, we have a derived structure like

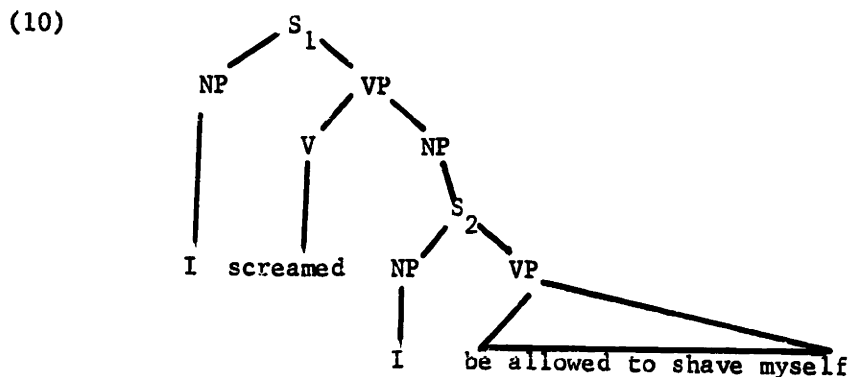

On the third (S_1) cycle, the (derived) subject of the sentence embedded beneath scream is in fact identical to the subject of scream. The structural description of Equi-NP Deletion is therefore met, and Equi-NP Deletion in fact applies. According to Lakoff's formalism, either of these two occurrences in the course of the derivation of a sentence with scream should cause the resulting sentence to be ungrammatical. But (8) is perfectly grammatical. We must conclude that Lakoff's formalism is incorrect.

If, on the other hand, the unlike-subject constraint is a deep structure constraint, as proposed here, it does not matter whether or not the structural description of Equi-NP Deletion is met or the rule applies, as long as the subject of a sentence embedded beneath scream is not identical to the subject of scream in deep structure.³ This condition is satisfied in (9), the structure underlying (8). The grammaticality of (8) is therefore evidence that the unlike-subject constraint is a deep structure constraint.⁴

It might be thought that a deep structure constraint like the unlike-subject constraint in English is essentially a 'null transformation' which would require that the subject of a sentence embedded beneath verbs like scream be non-identical to the subject of scream. But this constraint differs from a transformation not only in that it effects no change in phrase markers, but, more important, in that its 'structural description' must be met if a grammatical sentence is to result. For this reason, the unlike-subject constraint is not like an obligatory transformation, which applies if its structural description is met, but it is rather a well-formedness condition on the input to the transformational component. To call it a 'null transformation' is therefore to use the term 'transformation' in an entirely new way. Furthermore, if well-formedness conditions on trees like the unlike-subject constraint were transformations, they could be ordered with respect to other transformations. This would be an exceedingly powerful device, since such filters could be applied at any stage of derivations. However, it seems that we can constrain this filtering device and claim that they are to be applied only to phrase markers which constitute the input to the transformational component. For this reason we call the device that is needed to state the unlike-subject constraint in English a deep structure constraint.

1.2 The like-subject constraint in Serbo-Croatian.

In Serbo-Croatian an embedded sentence may be introduced by the complementizer da in sentences like

(11) a. Želim da idem.

'I want that I go: I want to go.'

b. *Želim da ideš.*

'I want that you go: I want you to go.'

c. *Želim da Rastko ide.*

'I want that Rastko go: I want Rastko to go.'

There is also an infinitival complementizer. Serbo-Croatian does not have an 'accusative plus infinitive' construction, and the distribution of the infinitival complementizer is much more restricted than that of the *da* complementizer. Whereas *da* occurs in full paradigms like (11), we may use the infinitival complementizer only in the realization of the deep structure underlying (11a). Its use in sentences like (11b) and (11c) results in ungrammaticality:

(12) a. *Želim ići.*

'I want to go.'

b. **Želim ti ići.*

'I want you to go.'

c. **Želim Rastka ići.*

'I want Rastko to go.'

In a paradigm in which the verb *željeti* 'want' has a second person singular subject we find:

(13) a. **Želiš mi ići.*

'You want me to go.'

b. *Želiš ići.*

'You want to go.'

c. **Želiš Rastka ići.*

'You want Rastko to go.'

The appearance of the infinitival complementizer, then, is predictable: it can occur only in sentences in which the subject of the embedded sentence is identical to the subject of the matrix sentence. The subject of the embedded sentence must have been deleted in order for the infinitival complementizer to appear, for the embedded subject never shows up together with the infinitival complementizer.

We can capture these generalizations by positing an optional rule of Equi-NP Deletion in Serbo-Croatian which deletes the subject of an embedded sentence if it is identical to the subject of the matrix sentence. In just those cases in which the subject of the embedded sentence has been deleted by Equi-NP Deletion the embedded sentence will be reduced to an infinitive. It is in this way that the infinitival complementizer will be introduced. In this I am following Kiparsky and Kiparsky (1968), who have proposed a similar analysis for English.⁵

This analysis squares with the facts of verb agreement in Serbo-Croatian. In sentences with the da complementizer the embedded verb is inflected to agree with its subject. (11a) derives from a structure like⁶

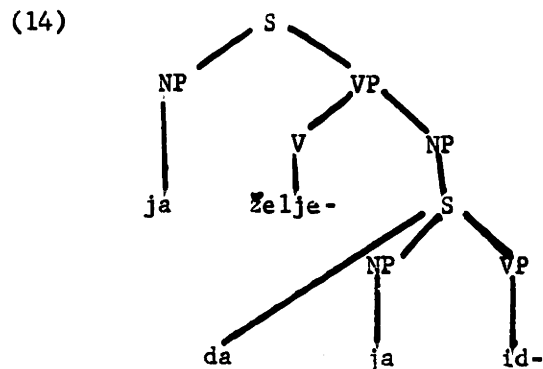

želje- and id- will now be inflected to agree with their subjects - ja in both cases. This will yield

(15) Ja *želim* da ja *idem*.

'I want that I go.'

Similarly, at this stage of derivations (11b) and (11c) are

(16) a. Ja *želim* da ti *ideš*.

'I want that you go.'

b. Ja *želim* da Rastko *ide*.

'I want that Rastko go.'

The embedded subjects ja, ti, and Rastko trigger verb agreement, so that the embedded verbs idem, ideš, and ide agree with their subjects ja, ti, and Rastko respectively. These inflected verb forms therefore testify to the presence of ja, ti, and Rastko in their respective sentences. At a later stage in derivations, all non-emphatic subject pronouns in Serbo-Croatian are deleted. At this point, (15), (16a), and (16b) are converted into (11a), (11b), and (11c) respectively. Now, we have postulated that in sentences with the da complementizer in surface structure Equi-NP Deletion has not taken place. The fact that in (11a) the embedded verb idem is inflected to agree with its subject ja supports this, since ja had to be present in order to trigger verb agreement. We hypothesized that the embedded infinitive results when the subject of the embedded sentence has been deleted by Equi-NP Deletion. In these cases the embedded verb is the infinitive ići, which is invariant in form. The lack of agreement on the infinitive squares with our hypothesis, which entails that since the subject of the embedded sentence has been deleted by Equi-NP Deletion, there is no subject for it to agree with. The fact that the embedded verb agrees with its subject in embeddings with the da complementizer but not in embeddings with the

infinitival complementizer thus squares with our hypothesis, according to which the embedded subject has been deleted in the latter case but not in the former.

Some additional support for this analysis comes from the so-called 'impersonal construction' (bezlična konstrukcija) of Serbo-Croatian. I will not justify the analysis of the impersonal construction here, but the essential point is that sentences in the impersonal construction have a [+ Pro, + Human] subject in deep structure which I will refer to simply as 'Pro;' by this is meant not any pronoun, but rather the same entity that appears in surface structure as on in French and as man in German. In Serbo-Croatian, the underlying Pro subject is deleted in the course of the derivation, and the morpheme se is inserted into structures from which this underlying subject has been deleted. This 'impersonal se' acts as a clitic pronoun in surface structure. As a result, a deep structure like

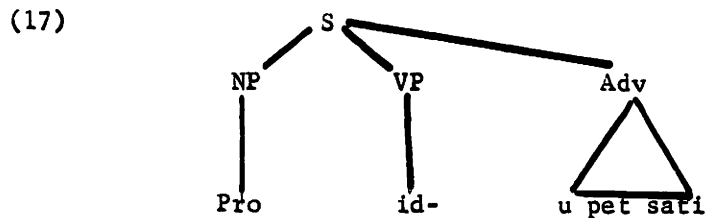

ends up as the sentence

(18) Ide se u pet sati.

go se at five o'clock

'Pro is going at five o'clock; on va à cinq heures.'

If this sentence is embedded beneath a sentence in which ja ('I') is the subject of želje- ('want'), we get the sentence

(19) Želim da se ide u pet sati.

'I want that Pro go at five o'clock. je veux qu'on aille
à cinq heures.'

The essential point is that the underlying [+ Pro, + Human] subject is spelled out by a transformation as the morpheme se.

Now, the underlying Pro subject of the impersonal construction, like any other subject noun phrase, is subject to the application of Equi-NP Deletion if it is identical to the subject of the matrix sentence. Hence, if we have a deep structure like

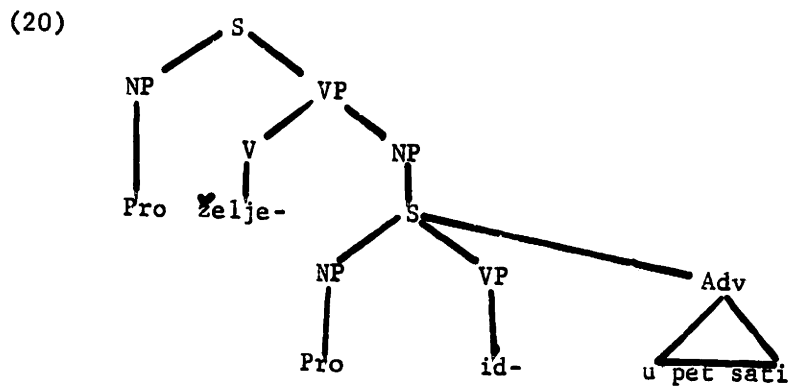

Equi-NP Deletion should be able to apply optionally. If our hypothesis is correct, the deletion of the subject of the embedded sentence should cause the appearance of the infinitival complementizer. Without application of Equi-NP Deletion we will get the da complementizer. Now, we have seen that the underlying Pro subject is spelled out as the morpheme se. Therefore, the number of se's in the final string should correspond to the number of instances of this Pro subject. If the infinitive arises as a result of the deletion of the embedded subject, only one se should be possible with the infinitival complementizer. This is indeed the case.

(21) *Želi se ići.*

'Pro wants to go; on veut aller.'

(22) **Želi se ići se.*

If the embedded subject has not been deleted, we should have two instances of the Pro subject, hence two instances of se in the surface structure. This too is the case.

(23) *Želi se da se ide.*

'Pro wants to go; on veut aller.'

(21) and (23) are synonymous, as are (11a) and (12a). The fact that we get two se's with the da complementizer but only one with the infinitival complementizer supports our hypothesis that the infinitive arises as a result of the removal of the subject of the embedded sentence.

Having established that the infinitival complementizer results from the deletion of the subject of the embedded sentence, we are now in a position to consider the evidence that certain verbs in Serbo-Croatian manifest a deep structure constraint to the effect that the subject of a sentence embedded beneath them must be identical to their own subject. We will see that Lakoff's notion of 'absolute exception' to the rule of Equi-NP Deletion, requiring both that the structural description of Equi-NP Deletion be met and that the rule actually apply, cannot adequately account for the facts in Serbo-Croatian.

The verb namjeravati 'intend' exhibits the properties in question. We find sentences like

(24) *Namjeravam da idem.*

'I intend that I go; I intend to go.'

with the da complementizer and inflection of the verb idem to agree

with its first person singular underlying subject ja. In addition there are grammatical sentences with the infinitival complementizer like

(25) Namjeravam ići.

'I intend to go.'

in which Equi-NP Deletion has deleted the subject of the embedded sentence, resulting in an infinitive. (24) and (25) are analogous to (11a) and (12a). What makes namjeravati different from željeti is the fact that whereas (11b) and (11c) with željeti are grammatical, the corresponding sentences with namjeravati are not.

(26) a. *Namjeravam da ideš.

'I intend that you go.'

b. *Namjeravam da Rastko ide.

'I intend that Rastko go.'

Sentences with namjeravati are grammatical just in case the subject of the embedded sentence is identical to the subject of namjeravati. The paradigm with a second person singular subject is therefore:

(27) a. *Namjeravaš da idem.

'You intend that I go.'

b. Namjeravaš da ideš.

'You intend to go.'

c. *Namjeravaš da Rastko ide.

'You intend that Rastko go.'

It is clear that the formalism of 'absolute exceptions to Equi-NP Deletion' cannot account for these facts. To use this formalism we would

have to require that the structural description of Equi-NP Deletion be met and that the rule actually apply. But in (24) and (27b) Equi-NP Deletion has not applied. If it had, an infinitive would have resulted. The constraint on the subject embedded beneath verbs like namjeravati, then, is not statable as a constraint on the Equi-NP Deletion transformation.

It is now reasonable to ask whether it still might be possible to devise some way of stating this constraint as a transformational constraint. Two ways of doing this suggest themselves, and we shall examine them in turn.

The first way that comes to mind of stating the like-subject constraint in Serbo-Croatian by means of transformations would be to require that the structural description of the Equi-NP Deletion transformation be met, even though the rule need not actually apply. To do this would require a change in the theory of grammar, but it would be able to account for the facts of (24), (26), and (27). While this seems a highly dubious maneuver, rather than discuss its undesirability I will simply point out that there are other facts in Serbo-Croatian which it cannot handle. The Equi-NP Deletion transformation in Serbo-Croatian must be constrained so that the subject of the embedded sentence will be deleted only if it is identical to the subject of the higher sentence; it is never deleted upon identity to the object of the higher sentence. As a result, Equi-NP Deletion does not apply with verbs like prisiliti 'force' and other verbs which occur in the type of structure that Rosenbaum calls 'transitive verb phrase complementation.' But all of the verbs which occur in these structures require that the subject of the embedded sentence be identical to the object of the matrix sentence. With a first person singular object in the matrix

sentence, then, we find

(28) a. *Prisilio mi je da idem.*

'He forced me that I go; he forced me to go.'

b. **Prisilio mi je da ideš.*

'He forced me that you go.'

c. **Prisilio mi je da ide.*

'He forced me that he go.'

while with a second person singular object in the matrix sentence we find

(29) a. **Prisilio ti je da idem.*

'He forced you that I go.'

b. *Prisilio ti je da ideš.*

'He forced you that you go; he forced you to go.'

c. **Prisilio ti je da ide.*

'He forced you that he go.'

In each case the subject of the embedded sentence must be identical to the object of the matrix sentence. But there is no possibility of stating this constraint by requiring that the structural description of Equi-NP Deletion be met, for the structural description must specifically be constrained so as to exclude its application to these structures in order to avoid converting the structures underlying (28a) and (29b) into the ungrammatical

(30) **Prisilio mi je ići.*

'He forced me to go.'

and (31) **Prisilio ti je ići.*

'He forced you to go.'

respectively. Hence it simply will not do to require that the structural description of Equi-NP Deletion be met.

A second possibility might be to look for some other transformation in terms of which to state the like-subject constraint as a transformation constraint. Such an attempt would be misguided, however, because in the case of verbs like namjeravati ('intend') the constraint holds between the subjects of two (vertically) adjacent sentences and Equi-NP Deletion is the only transformation that looks at these two noun phrases. In the case of verbs like prisiliti ('force'), moreover, the constraint holds between two noun phrases which are not looked at by any transformation in the grammar.

For these reasons, we can not use the transformations of Serbo-Croatian to reject as ungrammatical any sentence in which the subject of a sentence embedded beneath namjeravati is not identical to the subject of namjeravati, or a sentence in which the subject of a sentence embedded beneath prisiliti is not identical to the object of prisiliti. We need deep structure constraints to do this. As was pointed out in connection with the unlike-subject constraint in English, these constraints differ from transformations not only in that they effect no change in phrase markers, but also in that their 'structural description' must be met if a grammatical sentence is to result. They are therefore different from obligatory transformations, which apply if their structural description is met. Furthermore, if they were transformations they could be ordered with respect to other transformations. This would give us an exceedingly powerful device. It seems that we can constrain these filtering devices and claim that they apply only to the input to the transformational component.

The deep structure constraints proposed here are essentially an extension of the devices proposed in Chomsky (1965) to handle strict subcategorization and selectional restrictions. While the examples of the latter that were given in Chomsky (1965) were of a rather local nature and were restricted to phenomena within a simplex sentence, the like-subject and unlike-subject constraints have as their domain a sentence and its complement. Such domains exist only in a theory like that of Chomsky (1965) which posits generalized phrase markers. In earlier theories of transformational-generative grammar, such as those represented by Chomsky (1957) and Lees (1960), embedding was not already given in generalized phrase markers, but was accomplished by (generalized) transformations. For a variety of empirical reasons, it was necessary for transformations, including the passive transformation, to apply to simplex sentences prior to embedding. As a result the subject of a sentence at the point in derivations when it was embedded in another sentence might be different from what it had originally been. In the earlier version of the theory, then, it was possible to check for identity or non-identity of the subjects of the matrix and constituent sentences at the time of embedding, but not earlier. The earlier theory would have been able to incorporate a stipulation, for example, that the subject of a sentence embedded into a sentence with the verb scream must be non-identical to the subject of scream, but it would have been able to check for non-identity only at the stage in derivations at which embedding took place. It would therefore have been able to rule out as ungrammatical such sentences as

- (6) a. *I screamed for me to commit myself.
 b. *I screamed to commit myself.

but it would not have been able to account for the grammaticality of sentences like

(8) I screamed to be allowed to shave myself.

These facts are accounted for, however, in a theory in which deep structure constraints are stated on generalized phrase markers. That the earlier theory could not state such facts shows that the earlier theory not only allowed too great a range of possibilities for the ordering of transformations, as shown in Chomsky (1965), but also that the earlier theory was inadequate in principle. It shares this inadequacy with the transformational theory of Zellig Harris, which, dealing with relations among sentences, lacks generalized phrase markers and is therefore unable to account for the difference in grammaticality between *(6) and (8). The existence of pre-transformational constraints across sentence boundaries is the strongest kind of evidence for a theory with generalized phrase markers.

It is easier to show that the like-subject constraint is not a transformational constraint in Serbo-Croatian than it is in English because of sentences like (24), *(26), (27), (28), and (29), in which the two relevant noun phrases must be identical, and there is no way to account for this required identity in terms of the Equi-NP Deletion transformation. This is even more readily visible in a language like Bulgarian, which has no rule of Equi-NP Deletion at all.⁷ What is even more striking is the fact that synonymous verbs in different languages seem to manifest the like-subject constraint. It is the same with the unlike-subject constraint. This suggests that these constraints may be universal and predictable on the basis of semantic properties of the

verbs in question. If this is the case, we would expect the like-subject and unlike-subject constraints to be deep structure constraints in all natural languages. In English, however, the verbs which we would expect to manifest the like-subject constraint can appear in sentences in which the subject of the embedded sentence which is identical to the subject of the matrix sentence is apparently a derived subject rather than a deep structure subject. In Chapter Two it is shown that such counterexamples are apparent rather than real, and that in such cases the verb in question does require that the embedded subject be identical to its own subject prior to the application of any transformations.

Footnotes to Chapter One

1. If we regard the examples dealt with in Chomsky (1965) by means of contextual features as examples of filtering, then no one would assume that all filtering in grammars is to be accounted for transformationally. The idea of using the transformational component to block derivations was proposed by Chomsky to account for cases where the base component generates generalized phrase markers - trees containing more than one sentence - which underlie no well-formed sentence. One could therefore take the position that all such cases are to be characterized as ungrammatical by means of some kind of blocking in the transformational component. Lakoff's attempt to use absolute exceptions to account for (1-6) can be viewed as an attempt to maintain this position. It is shown in Chapter One that this position cannot be maintained.

2. All tree diagrams in this dissertation are highly oversimplified, ignoring any aspects of the tree which are not relevant to the points under discussion. For this reason such things as verb tense, auxiliary verbs, and complementizers are systematically ignored. The general framework is that of Chomsky (1965) and Rosenbaum (1967), but some changes have been made in the deep structures posited in those works. In particular, I am following Kiparsky and Kiparsky (1968) in omitting the it of noun phrase complements posited by Rosenbaum where they are not relevant to the points under discussion. Rosenbaum's 'pronoun replacement

'transformation' is sometimes referred to here as 'It-Replacement' and sometimes by the Kiparskys' term of 'Raising.' No justification is offered here either for the basic framework or for the modifications made in it, since nothing that is crucial to the argument developed here seems to hinge on these points.

3. Another way to test this hypothesis would be to consider a deep structure like

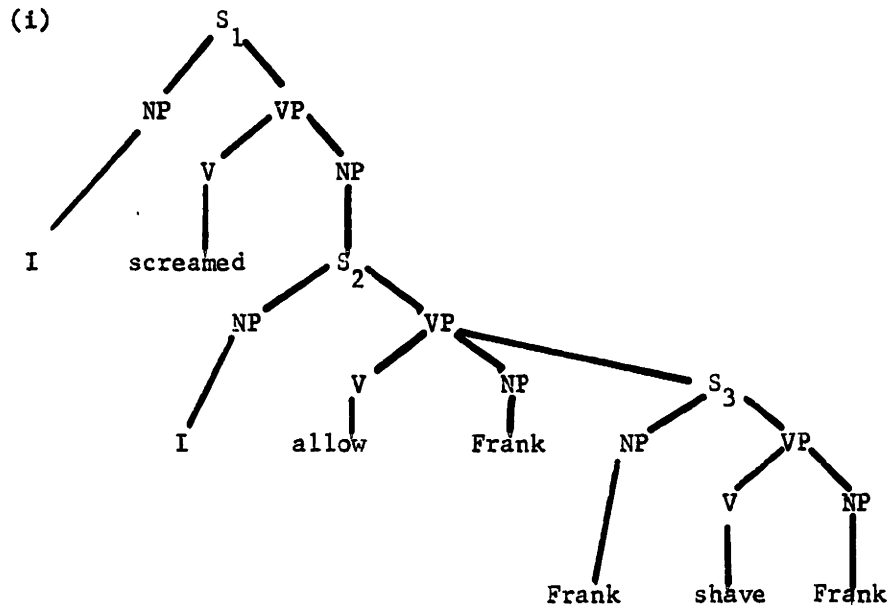

Here the subject of the sentence embedded beneath scream is identical to the subject of scream in deep structure. If the unlike-subject constraint is indeed a deep structure constraint, then this sentence should be ungrammatical no matter what happens in the course of its derivation. Using the notion of 'absolute exception' to Equi-NP Deletion, on the other hand, the resulting sentence should be grammatical if the structural description of Equi-NP Deletion is not met and the rule does not apply. We can

satisfy these two conditions in the following way. After Reflexivization has applied on the first (S_3) cycle and Equi-NP Deletion has deleted the subject Frank of S_3 on the second (S_2) cycle, let the passive transformation apply in S_2 . This will yield a derived structure like

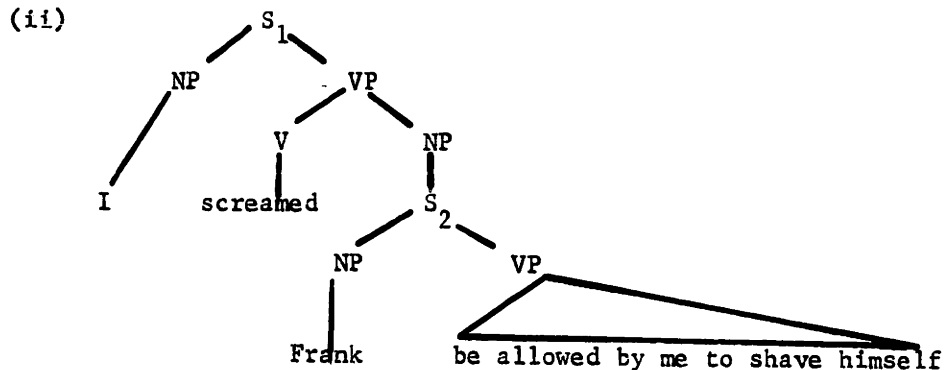

Now the (derived) subject of the sentence embedded beneath scream is non-identical to the subject of scream, so that on the third (S_1) cycle, the structural description of Equi-NP Deletion is not met and the rule can not and does not apply. According to Lakoff's formalism, the resulting sentence should be grammatical. But it is not:

- (iii) a. *I screamed for Frank to be allowed by me to shave himself.
 b. *I screamed for Frank to be allowed to shave himself by me.

If the unlike-subject constraint is a deep structure constraint, the ungrammaticality of *(iii) is correctly predicted, since the subject of S_2 is identical to the subject of S_1 in (i), the deep structure of *(iii). However, the validity of this argument is compromised by the fact that regardless of whether or not the verb in the matrix sentence is an unlike-subject verb, in sen-

tences in which the subject of the embedded sentence is identical to the subject of the matrix sentence, the passive transformation cannot apply in the embedded sentence without producing an ungrammatical sentence. If we substitute expect for scream in (i) and *(iii), then, the result is equally ungrammatical.

(iv) a. *I expected Frank to be allowed by me to shave himself.

b. *I expected Frank to be allowed to shave himself by me.

4. Note in passing that there are perfectly grammatical sentences with the verb scream in which the subject of the embedded sentence is identical to the subject of scream in deep structure. For example:

(v) I screamed that I would go.

The unlike-subject constraint is operative in sentences like (5) and *(6), but not in (v). We are therefore faced with the question of how to characterize this difference. At first glance the difference between the two kinds of sentences appears to be due to the fact that (5) and *(6) have the infinitival complementizer, while (v) has the that complementizer. If this is the correct characterization of the difference between (5) and *(6), on the one hand, and (v), on the other, then the unlike-subject constraint must be restricted to sentences with the infinitival complementizer. We will not deal with this problem here. It suffices here to have pointed out that this constraint does not apply to every sentence with a verb having the phonological shape scream.

5. The situation is somewhat more complicated in English, since in English there is also a rule of Raising or It-Replacement which takes an NP out of the embedded sentence and moves it up into the higher sentence. This rule converts structures like

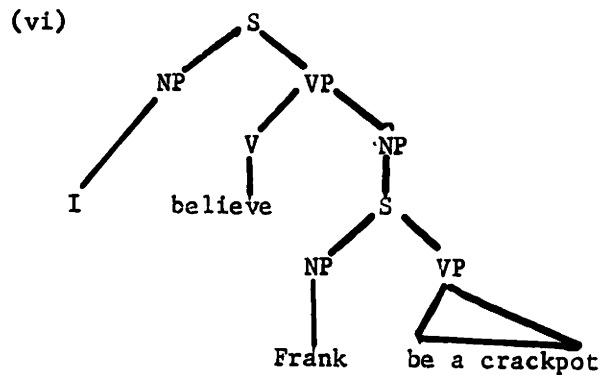

to structures like

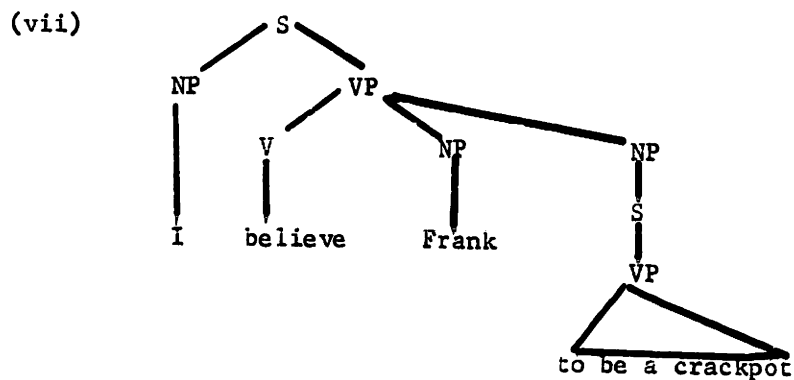

yielding sentences like

- (viii) I believe Frank to be a crackpot.

That the NP Frank is indeed moved up into the higher sentence can be seen from such examples as

- (ix) I believe myself to be a crackpot.

where the reflexive pronoun myself could not have arisen if the subject I of the embedded sentence had not been moved up into the higher sentence, since, as Lees and Klima (1963) have shown, Reflexivization in English must be limited to a single simplex

sentence in order to prevent such ungrammatical sentences as

(x) *I believe Bill to have insulted myself.

Now, the appearance of the infinitive in sentences like (viii) and (ix) does not run counter to the Kiparskys' proposal, since the correct generalization is that the infinitive appears whenever the subject NP has been removed from the embedded sentence during the course of a derivation. The infinitive appears regardless of whether the subject NP has been removed by a deletion rule, such as Equi-NP Deletion, or by some such rule as Raising.

6. These verbs are represented in tree diagrams as zelje- and id- so as to be neutral between their inflected and infinitival forms.
7. I am indebted to Wayles Browne for this information about Bulgarian.

CHAPTER TWO

The Like-Subject Constraint in English

2.0 Evidence that the like-subject constraint in English is a deep structure constraint.

In Chapter One evidence was presented to show that neither the unlike-subject constraint in English nor the like-subject constraint in Serbo-Croatian is statable as a transformational constraint. In this chapter it is shown that this is also true of the like-subject constraint in English.

At issue is the question of how grammars are to state facts of the kind noted by Rosenbaum (1967) to the effect that with certain verbs a grammatical sentence results only if the subject of the complement sentence is identical to the subject of the matrix sentence.

(1) I condescended to go.

is fully grammatical, while

(2) *I condescended (for) Clyde to go.

is not. If the proposal of Lakoff (1965) is correct and verbs like condescend are to be marked in the lexicon as 'absolute exceptions' to Equi-NP Deletion, requiring that the structural description of this rule be met and that it actually apply, a grammatical sentence should result if the subject of the embedded sentence is identical to the subject of the matrix sentence at the stage in derivations at which Equi-NP Deletion applies, regardless of whether the subjects of the two sentences were identical in deep structure. For this reason, Lakoff's proposal is unable to account for the fact that while

(3) I condescended to allow him to go.

is grammatical,

(4) *I condescended to be allowed to go.

is not. The deep structure of *(4) is something like

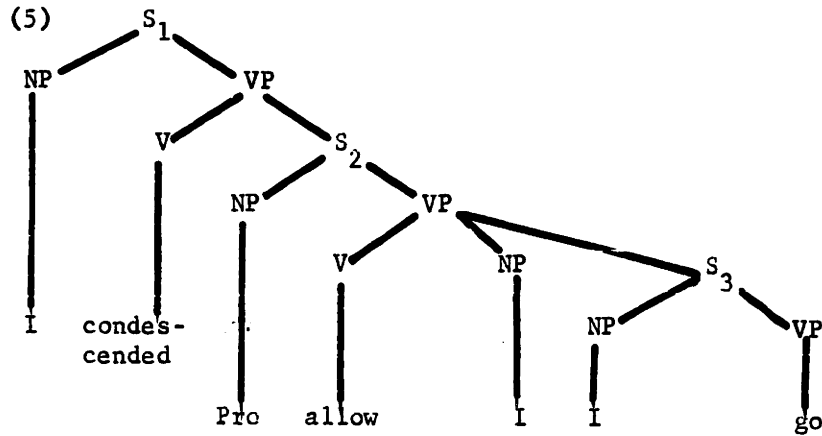

On the second (S₂) cycle, after Equi-NP Deletion has deleted the subject of S₃ and the passive transformation has applied in S₂, we have a derived structure like

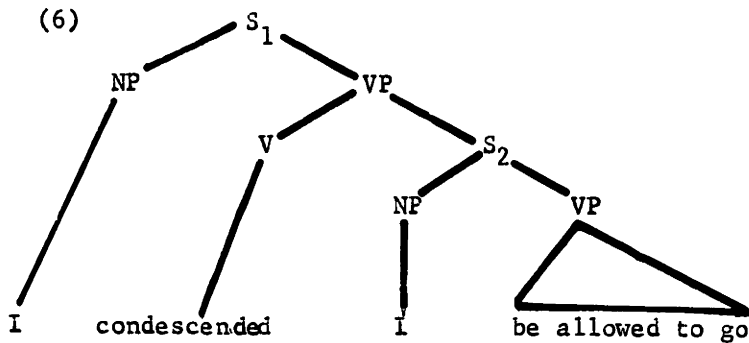

On the third (S₁) cycle, Lakoff's requirements that the structural description of Equi-NP Deletion be met is satisfied. If Equi-NP Deletion applies, Lakoff's second condition will also be satisfied, and a grammatical sentence should result. But the resulting sentence *(4) is ungrammatical. Since treating the like-subject constraint with condescend as an absolute exception to Equi-NP Deletion results in an incorrect prediction, we must reject this hypothesis. There is no other transformation in English that looks at the subject of a sentence and the subject of its complement, so there is no other transformation we might attempt to use to 'block' sentences like *(4). If the like-subject constraint in English is a deep structure constraint, however, we correctly predict

that *(4) is ungrammatical, for in (5), the deep structure of *(4), the subject of the sentence embedded beneath condescend is not identical to the subject of condescend. The ungrammaticality of *(4), then, shows that the like-subject constraint in English, like that in Serbo-Croatian, cannot be stated transformationally and must therefore be stated as a deep structure constraint.

There are, however, several apparent counterexamples to the claim that the like-subject constraint in English is a deep structure constraint. We will now deal with these cases, providing evidence that, despite the appearances, the constraint is really deep structural.

2.1 Apparent counterexamples.

2.1.1 Passive Cases.

Many speakers of English accept as grammatical such sentences as

(7) I tried to be arrested.

(8) I condescended to be arrested.

These sentences are apparent counterexamples to the claim that the like-subject constraint in English is a deep structure constraint. The deep structure of (7), for example, is ostensibly something like

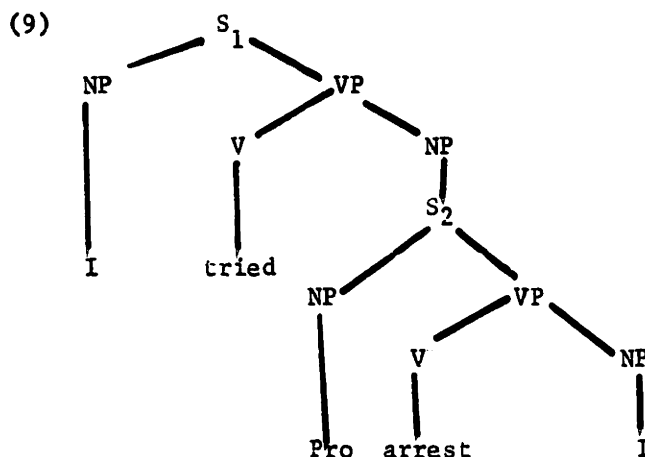

in which the subject of the sentence embedded beneath try is not identical to the subject of try. It is only after the passive transformation has applied in the embedded sentence that the subjects of the two sentences are identical.

If we examine the meaning of (7), we find that the proposed deep structure (9) fails to represent that meaning adequately. (7) means something like 'I tried to get arrested.' 'I tried to get myself arrested,' or 'I tried to let myself be arrested.' If the deep structure of (7) is to represent this meaning, it must contain three sentences rather than two. Instead of (9), it would have to be something like¹

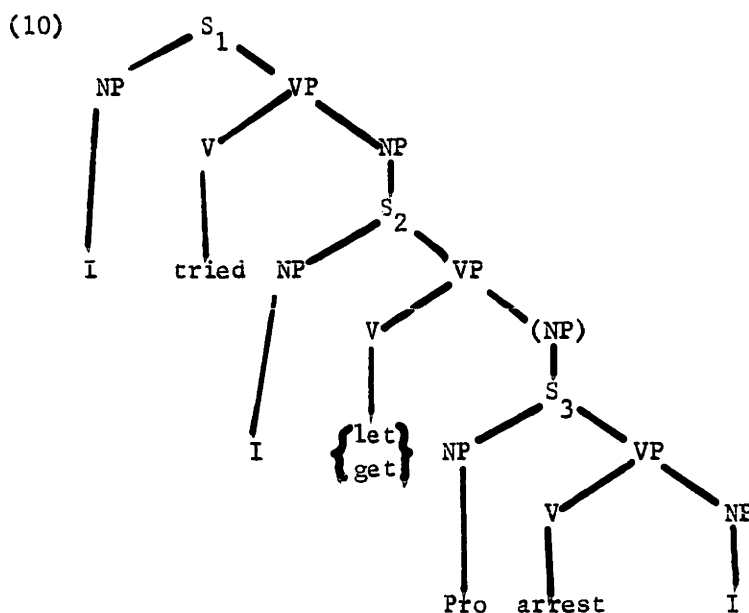

(10) as the deep structure of (7) correctly incorporates the fact that (7) is understood to mean that I tried to do something the result of which would be that I end up arrested. It does this by including S_2 , which has I as its subject, in addition to S_1 and S_3 . The identity of the verb in S_2 remains to be determined. On semantic grounds it is probably something like get or let, but since I have given no evidence

for one verb rather than another in this position in (10), I have left it indeterminate. The point is that in order for the meaning of (7) to be represented in deep structure, the intervening sentence S_2 is needed between S_1 and S_3 . The verb of S_2 would then be deleted at some point in the course of the derivation of the surface form of sentences like (7).

If the deep structure of (7) is indeed (10) rather than (9), its deep structure would satisfy the deep structure constraint that the subject below try must be identical to the subject of try. Sentences like (7) would therefore not constitute genuine counterexamples to the claim that the like-subject constraint in English is a deep structure constraint.

At this point we are faced with a choice. The question is whether (9) or (10) is the correct deep structure of (7). If (9) is correct, we must somehow account for the meaning of (7), which has an additional element like let or get in it. If we postulate (9) as the deep structure of (7), then, we must assume that this aspect of the meaning of (7) is accounted for in the semantic component. This is not unreasonable, for it can be plausibly argued that the ability to bring something about is in some sense part of the meaning of verbs like try, which must be included in the semantics of these verbs in any event. This position can be made to look more plausible by pointing to the purely syntactic difficulties associated with a deep structure like (10) for (7). In the first place, it is not clear what the verb of the intervening sentence S_2 would be. Second, it is not at all clear under what circumstances the rule which would have to delete it applies, how wide a range of sentences contain such intervening sentences, and so on. Positing an

intervening sentence like S_2 in (10) appears to have a rather ad hoc flavor, since it is used only for semantic interpretation and to maintain the claim that the like-subject constraint is a deep structure constraint. If the semantics of sentences like (7) are due to semantic properties of the verbs in question rather than to the inclusion of an intervening sentence like S_2 of (10) in the deep structure, the only motivation for this intervening sentence is the claim that the like-subject constraint is a deep structure constraint. Since this intervening sentence does not actually show up in the surface forms of sentences, (9) seems to be a much more solidly grounded deep structure for (7) than (10) does.

To point out these difficulties with postulating (10) as the deep structure of (7) is not to conclude that the correct deep structure is (9), but merely to pose the problem. If the semantics of verbs like try includes the idea of ability to bring something about, and if (10) turns out to be the correct deep structure of (7), then the semantics of such verbs might be able to provide the basis for an explanatory hypothesis to explain why there is an intervening sentence like S_2 in (10). If there are syntactic difficulties involved in the attempt to derive (7) from (10) but not from (9), that does not indicate that (9) is the correct deep structure of (7). The question of which of these two deep structures is correct is an empirical question, and can only be answered in terms of empirical evidence. If the verbs which manifest the like-subject constraint share certain semantic properties, as seems to be the case, then the question at issue is whether these semantic properties are reflected in the underlying syntactic structure of sentences with these verbs. If (10) is the correct

deep structure of (7), they are; if (9) is, they are not. Since the question at issue concerns the underlying syntactic structure of sentences like (7), it can be answered only by reference to syntactic evidence. If we can show that on purely syntactic grounds (10) is an adequate deep structure of (7) while (9) is not, we must abandon (9) in favor of (10) as the deep structure of this sentence. We will then have shown that postulating the intervening sentence S_2 of (10) is not at all ad hoc, but rather that a deep structure like (9) which does not include such an intervening sentence is syntactically inadequate. It will then follow from this that sentences like (7) are not counterexamples to the claim that the like-subject constraint in English is a deep structure constraint.

We will now proceed to show that there are syntactic facts which can not be handled by a grammar which posits (9) as the deep structure of (7), but which are correctly predicted by a grammar in which the deep structure of (7) is (10). Since the former grammar requires only that the derived subject of the embedded sentence be identical to the subject of the matrix sentence, we will call it the derived subject theory. The latter grammar, in which the like-subject constraint is a deep structure constraint, we will call the deep subject theory.

Both theories correctly predict that (7) and (8) will be accepted by speakers of English. But the theories differ in that the derived subject theory predicts that a grammatical sentence will result whenever the derived subject of the embedded sentence is identical to the subject of the like-subject verb in the matrix sentence, while the deep subject theory predicts that a grammatical sentence will result only if there is an intervening sentence with a verb like 'let' or 'get' and a subject

identical to that of the matrix sentence. The crucial evidence which will decide between the two theories, then, will come from cases where the derived subject is identical to the subject of the matrix sentence, but where, for independent reasons, there cannot be an intervening sentence with a verb like let or get. These conditions are met with verbs like say and rumor, which take infinitival complements only in passivized sentences. We have sentences like

(11) Karl was said to enjoy surfing.

(12) Karl was rumored to enjoy surfing.

whose deep structure must be something like

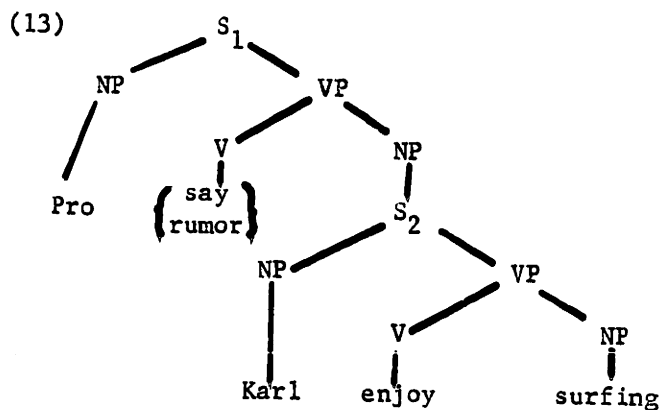

On the second cycle the subject of the lower sentence undergoes Raising into the higher sentence, where it undergoes the passive transformation and ends up as the derived subject of the sentence. These sentences can decide between the two theories because they cannot occur beneath verbs like let and get.

(14) *Karl let himself be rumored to enjoy surfing.

(15) *Karl got himself rumored to enjoy surfing.

(16) *Karl got rumored to enjoy surfing.

The derived subject theory predicts that (11) and (12) can be embedded beneath verbs like try and condescend with Karl as subject, because the

derived subject of the embedded sentence is identical to the subject of the matrix sentence. The deep subject theory predicts that they cannot be embedded beneath such verbs because the deep subject in (13) is not identical to the subject of the higher sentence and these sentences cannot occur beneath let and get, as *(14-16) show. The resulting sentences

(17) *Karl condescended to be $\left\{ \begin{array}{l} \text{said} \\ \text{rumored} \end{array} \right\}$ to enjoy surfing.

(18) *Karl tried to be $\left\{ \begin{array}{l} \text{said} \\ \text{rumored} \end{array} \right\}$ to enjoy surfing.

are ungrammatical. We must therefore reject the derived subject theory in favor of the deep subject theory.

The deep subject theory makes other correct predictions which the derived subject theory fails to make. Note that sentences like

(19) We were misunderstood.

are ambiguous; they can indicate a particular act or incident of misunderstanding, or refer to our having been misunderstood over a period of time (a stative or durative meaning of misunderstood). When such sentences are embedded beneath let or get, however, the ambiguity disappears; only the sense in which a particular act or incident is referred to is possible.

(20) a. We let ourselves be misunderstood.

b. We got ourselves misunderstood.

And if we embed (19) beneath try or condescend, again only the single-incident reading is possible.

(21) a. We tried to be misunderstood.

b. We condescended to be misunderstood.

This fact follows automatically from the deep subject theory, but is unexplained in the derived subject theory.

If the deep subject theory is correct, then any restrictions that there are on what may occur with the intervening sentence with let and get should carry over to sentences in which we have a passive sentence embedded beneath a like-subject verb. One such restriction concerns what may be the deep structure subject of misunderstood when it is embedded beneath let or get. It must be a plural or collective noun phrase; it cannot be a singular or a conjunction of singulars.² As a result, there are grammatical sentences like

- (22) a. We got ourselves misunderstood by our friends.
 b. We got ourselves misunderstood by the public at large.

But the sentences

- (23) a. *We got ourselves misunderstood by Bill.
 b. *We got ourselves misunderstood by Joe, Frank, Pete, Harry and Mike.

are ungrammatical, although the lower sentence in each case is grammatical if it is not embedded beneath get.

- (24) a. We were misunderstood by Bill.
 b. We were misunderstood by Joe, Frank, Pete, Harry, and Mike.

The grammaticality of sentences like

- (25) a. We condescended to be misunderstood by our friends.
 b. We condescended to be misunderstood by the public at large.

is predicted by both the derived subject theory and the deep subject theory, but only the deep subject theory correctly predicts the ungrammaticality of

- (26) a. *We condescended to be misunderstood by Bill.
 b. *We condescended to be misunderstood by Joe, Frank, Pete, Harry, and Mike.

The fact that condescend requires that the verb embedded beneath it be [- Stative]³ provides additional evidence for the deep subject theory. This requirement accounts for the fact that although

(27) We knew them as the Fugs.

is grammatical,

(28) *We condescended to know them as the Fugs.

is not. Since know is [+ Stative], it cannot be embedded beneath condescend. The fact that the sentence

(29) We condescended to be known as the Fugs.

is grammatical constitutes crucial evidence for the deep subject theory over the derived subject theory. Since the derived subject theory postulates (9) as the deep structure of (7), it would likewise have to postulate

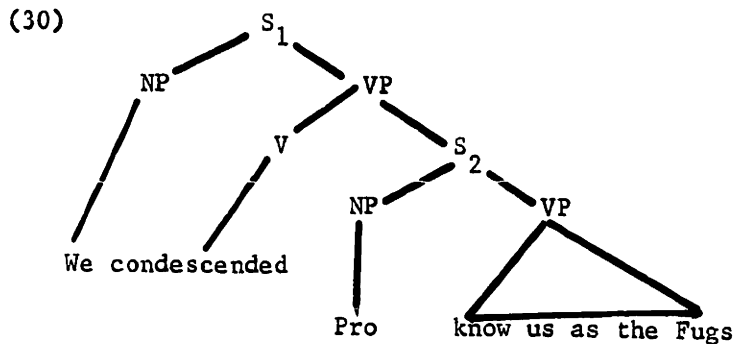

as the deep structure of (29). But since condescend cannot embed a [+ Stative] verb, as *(28) shows, the derived subject theory incorrectly predicts (29) to be ungrammatical. Under the deep subject theory, however, the deep structure of (29) is not (30) but rather:

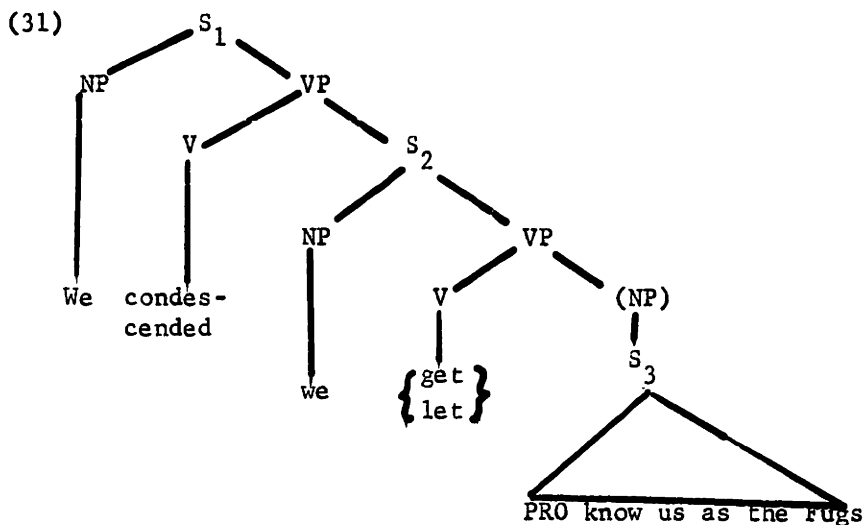

In this deep structure, the verb know is not embedded beneath condescend. For this reason, the constraint that condescend cannot embed a stative is not violated, and a grammatical sentence should result. The fact that (29) is indeed grammatical is therefore evidence for the deep subject theory over the derived subject theory.

Another argument for the deep subject theory comes from certain restrictions on the occurrence of subject-selected manner adverbials. We have sentences like

- (32) a. I was cleverly examined by Dr. Cronkite.
 b. I was intentionally examined by Dr. Cronkite.

But if these sentences are embedded beneath let or get these manner adverbials are no longer grammatical.

- (33) a. *I let myself be cleverly examined by Dr. Cronkite.
 b. *I got (myself) cleverly examined by Dr. Cronkite.

- (34) a. *I let myself be intentionally examined by Dr. Cronkite.
 b. *I got (myself) intentionally examined by Dr. Cronkite.

Now, if the deep subject theory is correct, then speakers who accept as grammatical such sentences as

- (35) I tried to be examined by Dr. Cronkite.

(36) I condescended to be examined by Dr. Cronkite.

should not accept sentences like

(37) a. *I tried to be cleverly examined by Dr. Cronkite.

b. *I tried to be intentionally examined by Dr. Cronkite.

(38) a. *I condescended to be cleverly examined by Dr. Cronkite.

b. *I condescended to be intentionally examined by Dr. Cronkite.

Since this prediction is borne out, we must accept the deep subject theory, which makes correct predictions, over the derived subject theory, whose predictions are incorrect.

There is a great deal of evidence, then, which leads us to reject the derived subject theory in favor of the deep subject theory. We conclude that the deep structure of sentences with a passive embedded beneath a like-subject verb like try or condescend such as (7) and (8) contains an intervening sentence with a verb like let or get, as is illustrated in (10).

In essentially the same way it can be shown that the like-subject constraint with verbs like persuade, force, and remind, which occur in deep structures which Rosenbaum (1967) calls instances of 'transitive verb phrase complementation,' is also a deep structure constraint.

Since we must rule out sentences like

(39) *I persuaded Clarabelle for Clem to plow the field.

in which the subject of the embedded sentence is not identical to the object of the matrix sentence, the question arises as to whether this is a transformational constraint or a deep structure constraint. Since many speakers accept sentences like

(40) I persuaded Marvin to be arrested.

it would appear at first glance that the constraint is transformational, i.e., that it is satisfied if the derived subject of the embedded sentence is identical to the object of the matrix sentence at the point in derivations at which Equi-NP Deletion applies. But if this is the case and the deep structure of (40) is consequently

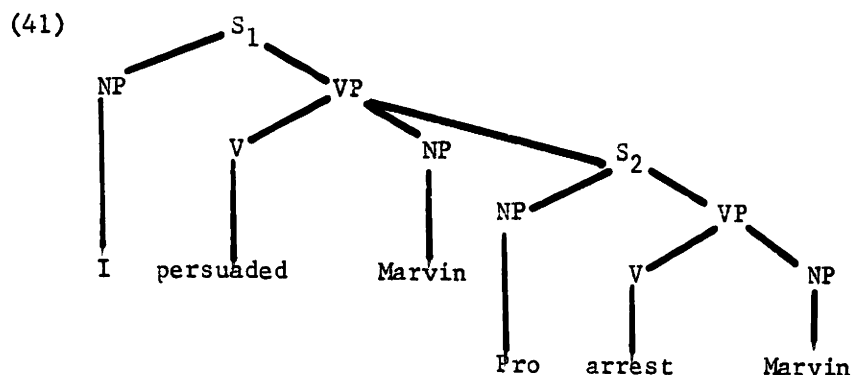

this deep structure does not adequately represent the meaning of (40), which is rather close to that of

- (42) a. I persuaded Marvin to let himself be arrested.
 b. I persuaded Marvin to get himself arrested.
 c. I persuaded Marvin to get arrested.

We are now faced with essentially the same question that confronted us earlier, when we had to decide whether (9) or (10) is the deep structure of (7). Is (41) the deep structure of (40), with the meaning of (40) handled by the semantic component in a way that is not understood at present, or is the meaning of (40) represented directly in its deep structure, so that the semantic component can interpret it in the usual fashion? If the meaning of (40) is represented in its deep structure, the deep structure of (40) must be something like

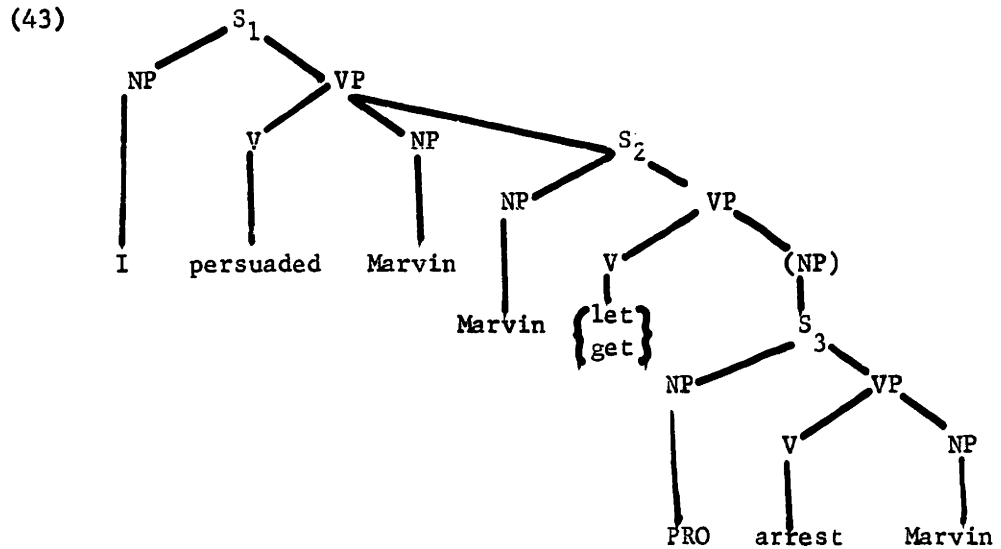

Since the question at issue is whether the semantics of sentences like (40) are reflected in their underlying syntactic structure, it is a syntactic question which can be answered only by means of syntactic evidence. And in this case, as in the case of sentences with try and condescend, there is purely syntactic evidence which indicates that the meaning of sentences like (40) is reflected in their underlying syntactic structure, and that the deep structure of (40) is consequently not (41) but rather (43).

First, the derived subject theory is unable to account for the ungrammaticality of sentences like

(44) *I persuaded Karl to be $\left\{ \begin{array}{l} \text{said} \\ \text{rumored} \end{array} \right\}$ to enjoy surfing.

Under the deep subject theory, which postulates (43) as the deep structure of (40), the ungrammaticality of *(44) is a direct result of the ungrammaticality of

- (45) a. *Karl let himself be $\left\{ \begin{array}{l} \text{said} \\ \text{rumored} \end{array} \right\}$ to enjoy surfing.
 b. *Karl got himself $\left\{ \begin{array}{l} \text{said} \\ \text{rumored} \end{array} \right\}$ to enjoy surfing.
 c. *Karl got $\left\{ \begin{array}{l} \text{said} \\ \text{rumored} \end{array} \right\}$ to enjoy surfing.

Second, although

(46) Marvin was misunderstood.

is ambiguous and can either refer to a particular act or incident of misunderstanding, or else have a stative or durative meaning,

(47) a. Marvin let himself be misunderstood.

b. Marvin got himself misunderstood.

have only the former reading. The fact that

(48) I persuaded Marvin to be misunderstood.

has only the former meaning follows automatically from the deep subject theory, but is unexplained under the derived subject theory.

Third, we note that the same restriction on what may be the subject of a stative verb embedded beneath let or get that we noted in (22) and *(23) shows up again when we have a passivized stative beneath persuade.

- (49) a. They let themselves be known as the Fugs by their friends.
- b. They let themselves be known as the Fugs by the public at large.
- c. *They let themselves be known as the Fugs by Bill.
- d. *They let themselves be known as the Fugs by Joe, Frank, Pete, Harry, and Mike.
- (50) a. I persuaded them to be known as the Fugs by their friends.
- b. I persuaded them to known as the Fugs by the public at large.
- c. *I persuaded them to be known as the Fugs by Bill.
- d. *I persuaded them to be known as the Fugs by Joe, Frank, Pete, Harry, and Mike.

Fourth, a sentence embedded beneath persuade and other verbs which occur in structures of transitive verb phrase complementation

may not have a [+ Stative] verb or adjective as its main verb. For this reason

(51) *I persuaded the boys to know them as the Fugs.
is ungrammatical. But with a passive in the lower sentence, the resulting sentence is grammatical.

(52) I persuaded the boys to be known as the Fugs.
This fact is an unexplained irregularity if (41) is the deep structure of (40), but it is correctly predicted if (43) is the deep structure, since with an intervening sentence in the deep structure of (52), know will not be embedded beneath persuade and the constraint which requires a non-stative beneath persuade will not be violated.

Finally, under the deep subject theory the ungrammaticality of subject-selected manner adverbials beneath let and get in sentences like

- (53) a. *I let myself be {cleverly
intentionally} examined by Dr.
Cronkite.
b. *I got (myself) {cleverly
intentionally} examined by
Dr. Cronkite.

automatically predicts the ungrammaticality of

- (54) *Zeke persuaded me to be {cleverly
intentionally} examined by
Dr. Cronkite.

The ungrammaticality of *(54) would be an unexplained irregularity if (41) were the deep structure of (40).

There is a variety of purely syntactic evidence, then, that (43) is the deep structure of (40). The same arguments showed (10) to be the deep structure of (7). This result has three consequences.

First, it shows that sentences like (7), (8), and (40) are not genuine counterexamples to the claim that the like-subject constraint is a deep structure constraint.⁴

Second, this result shows that, as tempting as it would be to posit (9) as the deep structure of (7) and (41) as the deep structure of (40) and to leave it to a semantic component about which almost nothing is known to account for the meaning of these sentences, to do so would be a mistake. The crucial question before us concerns the extent to which semantic properties of sentences are reflected in their syntactic structure. This question can be answered only by examining the relevant syntactic evidence.

Finally, our result has implications for a characterization of the ways that languages differ. While (7), (8), and (40) are accepted as grammatical by many speakers of English, there are languages in which the equivalent sentences are clearly ungrammatical. This is the case in Dutch, for example, where sentences like

(55) *Ik probeerde gearresteerd te worden.

I tried arrested to be

'I tried to be arrested.'

and

(56) *Ik dwong Piet gearresteerd te worden.

I forced Piet arrested to be

I forced Piet to be arrested.'

are ungrammatical. To express the English glosses of these sentences in grammatical Dutch, one must say

(57) Ik probeerde mij te laten arresteren.

I tried me to let arrest

'I tried to let myself be arrested.'

and

(58) Ik dwong Piet om sich te laten arresteren.

I forced Piet himself to let arrest

'I forced Piet to let himself be arrested.'

respectively.⁵ The deep structures of (57) and (58) are like (10) and (43) respectively. It thus turns out that the deep structures of the synonymous pairs of sentences in English and Dutch are the same, with the possible exception of whatever differences there may be in the corresponding lexical items in the two languages. English and Dutch differ in that English has a rule which deletes the verb which occurs in the intervening sentence S_2 in the deep structures (10) and (43), so that this verb does not show up in surface structure, while in Dutch there is no such deletion rule. As a result, the verb laten ('let') is present in surface structure in Dutch, as the difference in grammaticality between *(55-56) and (57-58) shows. If we had taken (9) and (41) to be the deep structures of (7) and (40) in English and attributed the meaning of let or get to an unknown rule of semantic interpretation, English and Dutch would have had different deep structures for the corresponding synonymous sentences, and the semantic component of English would have had a rule of interpretation which was absent in the semantic component of Dutch. It is, of course, not clear a priori that two languages can not differ in this way. The issue is at bottom an empirical one, and it is necessary to find empirical evidence to decide it one way or the other. Such evidence must come from particular cases in which two alternatives present themselves - a hypothesis under which two languages have the same deep structure for synonymous sentences and differ in some syntactic rule, and a theory under which the deep structures in the two languages are closer to the differing surface structures

and therefore differ from each other; the latter theory will typically (although not necessarily) involve a difference in the semantic components of the two languages, as was the case here, since English needed a rule of semantic interpretation that was not necessary in Dutch. The evidence that has been presented to show that the former alternative is correct in the case under discussion here, although it is of course not conclusive by itself, gives us some reason to think that solutions of the former type are likely to be correct.

We have concentrated on motivating the deep structures (10) and (43) for (7) and (40), and have said nothing about the transformation which the grammar of English must include in order to delete the intervening sentence with let or get to produce the surface structures of (7) and (40). We have also ignored the question of whether such intervening sentences may be present in the deep structure of other sentences as well and deleted by the same rule that is needed for (7) and (40), or whether such intervening sentences in deep structure are present only in the complements of verbs which manifest the like-subject constraint. These are some of the problems raised by our analysis.

The discovery that the like-subject constraint is a deep structure constraint that can not be handled as an absolute exception to Equi-NP Deletion raises another problem. How is the ungrammaticality of sentences like

(59) *I tried (for) Max to be swindled by me.

to be characterized? The deep structure is well-formed, and can be actualized as the grammatical sentence

(60) I tried to swindle Max.

But if the passive transformation applies in the embedded sentence, an

ungrammatical sentence results. This problem is not restricted to sentences with verbs which manifest the like-subject constraint, however, since, as John Ross has pointed out to me, an ungrammatical sentence always results if the passive transformation applies in an embedded sentence whose subject is identical to the subject of the matrix sentence. Thus, although

(61) I wanted to swindle Max.

is perfectly grammatical,

(62) *I wanted Max to be swindled by me.

is not. This sentence is grammatical only if me has some kind of emphatic stress.

(63) I wanted Max to be swindled by me.

the ungrammaticality of *(59) therefore has nothing to do with the fact that the verb of the matrix sentence is a like-subject verb. However, we should note that whereas (63), with emphatic stress on the deep subject of the embedded sentence, is grammatical, the corresponding version of *(59) is ungrammatical.

(64) *I tried (for) Max to be swindled by me.

However, this is not an isolated fact about English. It seems to be the case that in all languages, noun phrases that are required to be identical to a higher noun phrase by a deep structure constraint can not receive emphasis. In English this shows up in their inability to bear emphatic stress, as in *(64). This same property shows up in another way in Serbo-Croatian, where emphasis on a subject pronoun makes it immune to the rule which deletes subject pronouns. Alongside the unemphatic

(65) Želim da ideš.

'I want you to go.'

we find sentences like

(66) \checkmark *Želim da ti ideš.*

'I want you to go.'

The fact that the embedded subject pronoun ti ('you') has not been deleted indicates that it is bearing emphasis. Similarly, alongside the unemphatic

(67) \checkmark *Želim da idem.*

'I want that I go; I want to go.'

we also find

(68) \checkmark *Želim da ja idem.*

'I want that I go; I want me to go.'

in which the presence of the subject pronoun ja ('I') indicates emphasis. Now, if we take a verb like namjeravati ('intend'), which manifests the like-subject constraint, the sentence

(69) *Namjeravam da idem.*

'I intend that I go; I intend to go.'

is perfectly grammatical, but

(70) **Namjeravam da ja idem.*

'I intend that I go.'

is not. The presence of ja in *(70) indicates emphasis, but a noun phrase that is required to be identical to a higher noun phrase by a deep structure constraint can not bear emphasis. Hence *(70) is ungrammatical. The same fact shows up as the ungrammaticality of *(70) in Serbo-Croatian and that of *(64) in English. The inability to bear emphasis of a noun phrase that is required to be identical to a higher noun phrase in deep structure may in turn be explainable in terms of a universal requirement that such noun phrases undergo deletion. To

establish this, however, would take us well beyond the limits of this study. We have attempted to indicate here that the ungrammaticality of sentences like *(59) and *(64) does not reveal an inadequacy in our analysis, since the ungrammaticality of both examples can be explained by means of independently motivated principles.

Certain syntactic problems do remain in connection with the passive apparent counterexamples to the claim that the like-subject constraint in English is a deep structure constraint. They merit further study, but their existence in no way compromises the validity of the conclusions reached here.

2.1.2 NP* Cases.

In their study of what they call 'symmetric predicates,' Lakoff and Peters (1969) propose that the base component of grammars contains a rule:

(71) NP \rightarrow and NP*

This is a rule schema, which abbreviates the set of rules that begins as follows:

- (72) a. NP \rightarrow and NP NP
 b. NP \rightarrow and NP NP NP
 c. NP \rightarrow and NP NP NP NP

and continues without limit. This rule schema produces subparts of trees like:

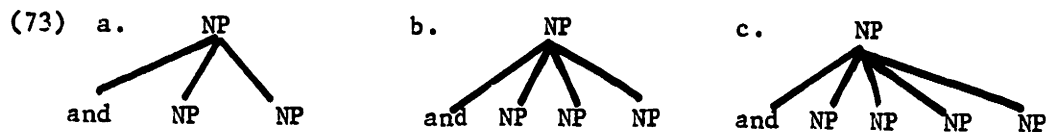

and so on. They also propose a rule of Conjunction Copying, which takes the initial and and adjoins it to the left of each of the NP's after the first: all and's but the last may later be deleted by an optional rule. In most of the discussion below, the and introduced by (72) is not relevant to the points at issue, and is consequently omitted from our tree diagrams. The important point about the rule (72) is that it introduces recursiveness of NP's into the base component of grammars.

In Lakoff and Peters' analysis the conjoined noun phrases introduced by the rule (72) in the base component appear as the subject of sentences like:

(74) Joe and Bill conferred.

(75) Joe and Bill are similar.

(76) Joe and Bill agreed.

(77) Joe and Bill met.

Under this hypothesis, the deep structure of (77) would consequently be:

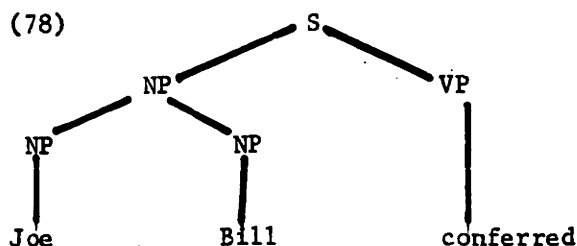

The basic motivation for such deep structures is the fact that the conjoined noun phrases in (74-77) can not be derived from sentential conjunction because of the ungrammaticality of:

(79) *Joe conferred and Bill conferred.

(80) *Joe is similar and Bill is similar.

(81) *Joe agreed and Bill agreed.⁶

(82) *Joe met and Bill met.

Part of Lakoff and Peters' paper is devoted to a justification of deep structures like (78) and hence of the rule (72).

A second proposal made by Lakoff and Peters is that there is a rule which they call 'Conjunct Movement', which converts the structures underlying (74-77) to the structures which end up as the sentences:

(83) Joe conferred with Bill.

(84) Joe is similar to Bill.

(85) Joe agreed with Bill.

(86) Joe met Bill.

respectively. This rule is constrained so as to apply only to binary structures in subject position, converting one of the two conjuncts into a surface structure object or prepositional phrase, as in (83-86).

The third topic with which the Lakoff-Peters paper is concerned is the problem of the extent to which the preposition used in the prepositional

phrase of sentences like (83-85) is predictable on the basis of other properties of the main verb or adjective.

The three points dealt with by Lakoff and Peters are to some extent independent. For example, the regularities in prepositions may still hold, even if there is no rule (72) in the base component or a rule of Conjunct Movement in the transformational component. The rule (72) may be correct, even if there is no rule of Conjunct Movement.

The only aspect of Lakoff and Peters' analysis with which we will be concerned here is the proposed rule of Conjunct Movement. This is relevant because, if (78) is the deep structure of (83), the grammaticality of sentences like

(87) Joe tried to confer with Bill.

(88) Joe condescended to confer with Bill.

(89) I forced Joe to confer with Bill.

constitutes a counterexample to our claim that the like-subject constraint is a deep structure constraint. If the Lakoff-Peters rule of Conjunct Movement is correct, the deep structure of (83) is (78) and the deep structure of (87) is consequently something like:

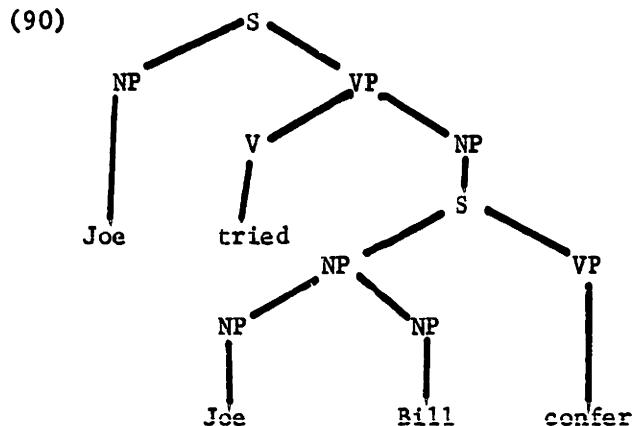

In this deep structure, the like-subject constraint is not satisfied, for the subject of the sentence embedded beneath try is the conjoined

noun phrase Joe and Bill and is therefore not identical to the subject of try, which is Joe.

If, on the other hand, there is no rule of Conjunct Movement, the deep structure of (83) is not (78) but rather something like:

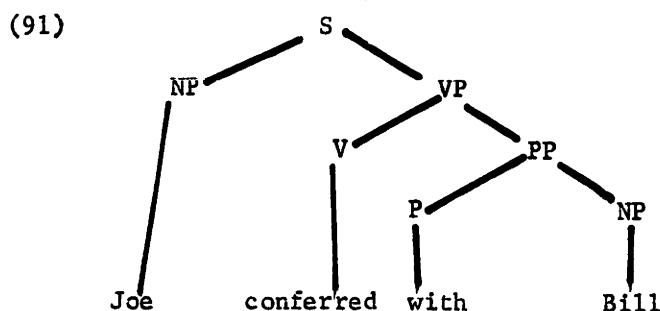

If this is the case, the deep structure of (87) is something like:

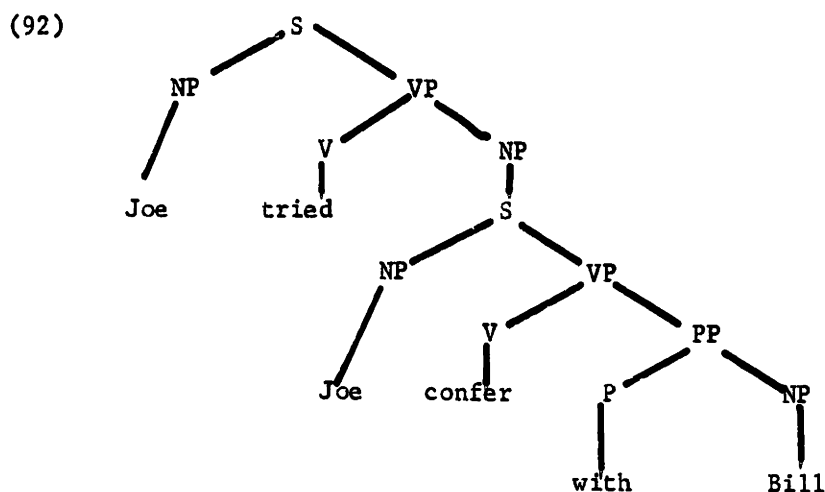

If (92) is the deep structure of (87), the like-subject constraint is satisfied in deep structure, and the grammaticality of (87) is not counterevidence to our claim that this is a deep structure constraint. Paragraph 2.1.2 is devoted to showing that there is no rule of Conjunct Movement, and that the deep structures of (83) and (87) are therefore (91) and (92) rather than (78) and (90).

Before looking at any of the syntactic evidence, on semantic grounds alone one would doubt that (74) and (83) are derived from the same deep structure, for they differ in meaning. This difference in

meaning becomes more apparent if such sentences are embedded.

- (93) a. I wanted to confer with Bill.
 b. I wanted Bill to confer with me.
 c. I wanted Bill and me to confer.

The three sentences in (93) are not synonymous. If meaning is determined on the basis of deep structure, then, they cannot all be derived from the same deep structure.

It is significant that the difference in meaning exhibited by sentences like (74) and (83) is not just a meaning difference which could be selected at random from among all the possible ways in which sentences can differ in meaning. The meaning difference bears precisely on the question of grammatical relations. It is the surface structure subject in each case that is understood as the subject or agent. Compare the sentences:

- (94) a. Joe agreed with Bill.
 b. Bill agreed with Joe.
 c. Joe and Bill agreed.

In (94a) it is Joe that does the agreeing. In (94b) it is Bill, and in (94c) it is both of them.⁷ Since in current linguistic theory grammatical relations are represented in deep structure, and since the surface structure subject of each sentence is the one that does the agreeing, it follows that the surface structure subject of each of these sentences must also be the subject in deep structure. From this it follows that (94a) and (94b) are not transformationally derived from the structure that underlies (94c), that is, there is no rule of Conjunct Movement.

There is also a good deal of purely syntactic evidence against the Conjunct Movement hypothesis.

The notion of transformation that developed in the work of Zellig Harris was that of an equivalence relation on the set of sentences of a

language. Different sentences that are deviant in the same way were said to be transformationally related. To use the active-passive relation as an example, the sentences

(95) *The baby drank the idea.

and (96) *The idea was drunk by the baby.

are deviant in the same way. If we pick an example that is not deviant, such as

(97) The baby drank the wine.

we find that the corresponding passive is also not deviant:

(98) The wine was drunk by the baby.

The active-passive relation, then, preserves sameness of deviance and non-deviance among different sentences. Such sameness-preserving relations among sentences Harris called 'transformations.'

With the development of the idea of generative grammar by Chomsky, Harris' notion of 'transformation' was put to work in a new way. Transformations now became mappings of phrase markers onto other phrase markers. The derivational history of a sentence became a series of phrase markers, with a transformational rule mapping each phrase marker in the series into the subsequent phrase marker. The notions of deep and surface structure are derivative from this, since they are simply the first and the last phrase markers in each such series of phrase markers.

The essential point in all of this is that transformations in current linguistic theory, like the Harrisian transformations from which they descend, preserve sameness of deviance or non-deviance of the sentences they relate. One qualification is in order here. There are cases where a well-formed deep structure is converted by a transformation into a structure which would be ungrammatical as it stands if it underwent no further

transformations. However, a subsequent obligatory transformation converts it into a grammatical sentence. This does not bear on Conjunct Movement, however, for if Conjunct Movement is a transformation at all it is an optional transformation. And optional transformations, in current theory as for Harris, preserve sameness of meaning, anomaly, and well-formedness of the structures they relate.

This is of relevance here because there seems to be an extraordinary amount of variation in different speakers' judgments of the grammaticality of the sentences that will now be cited as evidence against the Conjunct Movement transformation. The judgments of grammaticality reported here are my own, and there will be many who disagree with my judgments on particular sentences. What must be borne in mind, however, is that if Conjunct Movement is a transformation, it is an optional one and must preserve sameness of meaning, anomaly, and well-formedness of the sentences it relates. Therefore, if the Conjunct Movement hypothesis is correct, the sentences produced by application of Conjunct Movement should in each case be as grammatical as the putative source sentences from which they are derived. While other speakers may disagree with my judgments on particular sentences, it seems highly doubtful that in each case the sentence putatively derived by application of Conjunct Movement will be as grammatical as its supposed source sentence. Even if it is not the case that one sentence is fully grammatical and the other clearly ungrammatical, any difference in grammaticality between the two is evidence against the Conjunct Movement hypothesis. For the Conjunct Movement hypothesis predicts that the result of applying Conjunct Movement will in each case be as grammatical as the same sentence without Conjunct Movement. For this reason, the Conjunct Movement hypothesis fails in another respect; it is unable to account for the disparities in speakers'

judgments on these sentences.

Having clarified that an optional transformation must preserve sameness of grammaticality, meaning, and anomaly of the sentences it relates, we can show that Conjoint Movement is not a transformation, for it does not have this essential property of optional transformations. We have already seen that it does not preserve sameness of meaning among the sentences it supposedly relates. Now let us look at some examples which show that it does not preserve syntactic well-formedness or ill-formedness either.

Assuming the correctness of the Lakoff-Peters phrase structure rule (72), we will generate deep structures like

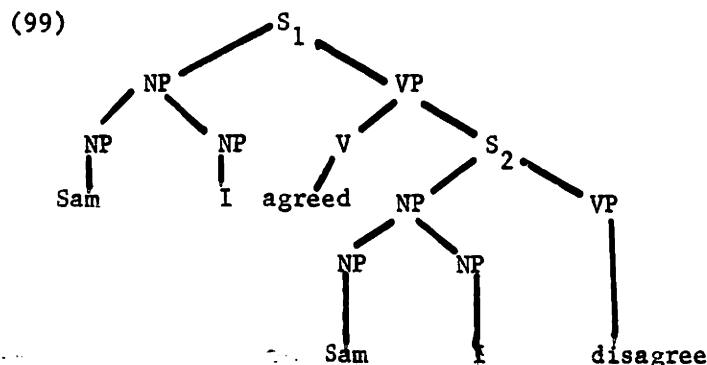

This is a well-formed deep structure. It will undergo Equi-NP Deletion and other transformations and will emerge as the grammatical sentence

(100) Sam and I agreed to disagree.

Now, if there is a Conjoint Movement transformation, we should be able to apply it to this structure. Such application should preserve the well-formedness of the sentence. But this is not the case. Application of Conjoint Movement to S_2 will yield outputs which, though they may not be wholly ungrammatical, are not impeccable sentences, as (100) is.

- (101) a. ??Sam and I agreed for me to disagree with him.
 b. ??Sam and I agreed for him to disagree with me.

The well-formedness of (100) is not preserved. If we attempt to apply Conjunct Movement to the conjoined subject of S_1 , the well-formedness of (100) is not preserved either. If Conjunct Movement applies after Equi-NP Deletion has deleted the conjoined subject of S_2 , the result is completely ungrammatical.⁸

- (102) a. *I agreed with Sam to disagree.
 b. *Sam agreed with me to disagree.

This shows that Conjunct Movement can not apply at any point after Equi-NP Deletion has deleted the subject of S_2 , i.e. Conjunct Movement can not be either a post-cyclical rule or a cyclical rule ordered after Equi-NP Deletion.⁹ If we try to apply Conjunct Movement before Equi-NP Deletion has had a chance to apply, thereby destroying the environment for Equi-NP Deletion and preventing it from applying, the result is not as ungrammatical as *(102), but it is still pretty bad.

- (103) a. ??I agreed with Sam for him and me to disagree.
 b. ??I agreed with Sam for me and him to disagree.
 c. ??I agreed with Sam for us to disagree.
 d. ??Sam agreed with me for him and me to disagree.
 e. ??Sam agreed with me for me and him to disagree.
 f. ??Sam agreed with me for us to disagree.

This shows that Conjunct Movement can not apply before Equi-NP Deletion has had a chance to delete the subject of S_2 , i.e. Conjunct Movement can not be either a pre-cyclical rule or a cyclical rule that is ordered before Equi-NP Deletion. We have already seen that Conjunct Movement can not apply in S_2 . *(102) and ??(103) show that if we try to apply Conjunct Movement in S_1 , Conjunct Movement can not be a post-cyclical rule, a pre-cyclical rule, a cyclical rule ordered after Equi-NP Deletion, or a cyclical rule ordered before Equi-NP Deletion. In other

words, Conjunct Movement can not be a rule at all. Regardless of the relative grammaticality of ??(101), *(102), and ??(103), it is clear that none of these sentences are fully grammatical in the sense that (100) is. Since optional transformations preserve sameness of grammaticality, Conjunct Movement is not a transformation.

Arguments of essentially the same type to show that Conjunct Movement is not a transformation can be constructed for any sentence which consists of a sentence with an NP* subject embedded beneath another sentence with an NP* subject, and where some trace of the embedded plural subject is preserved in the surface form of the sentence. Reflexive pronouns are such a trace in surface structure of an underlying plural subject. The deep structure

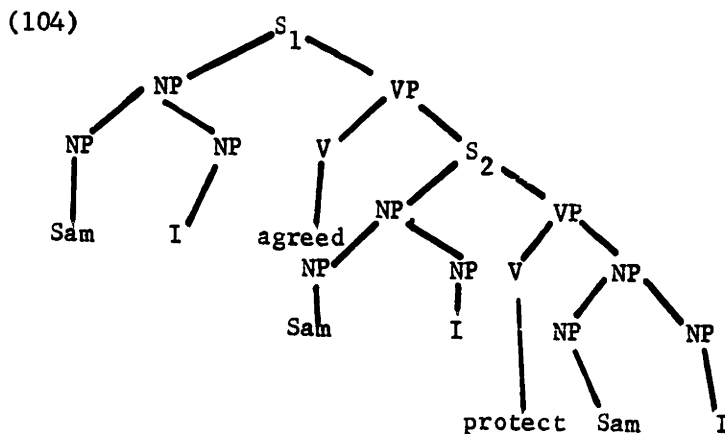

is well-formed and emerges as the grammatical sentence

(105) Sam and I agreed to protect ourselves.

If there is a Conjunct Movement transformation, it should be able to apply to this structure, preserving sameness of grammaticality. However, this is not the case. If we apply Conjunct Movement in S_1 after Equi-NP Deletion has deleted the subject of S_2 , we get the ungrammatical,

(106) a. *I agreed with Sam to protect ourselves.

b. *Sam agreed with me to protect ourselves.

If we apply Conjunct Movement before Equi-NP Deletion has ever had a chance to apply, we get the questionable sentences:

- (107) a. ??I agreed with Sam for him and me to protect ourselves.
 b. ??I agreed with Sam for me and him to protect ourselves.
 c. ??I agreed with Sam for us to protect ourselves.
 d. ??Sam agreed with me for him and me to protect ourselves.
 e. ??Sam agreed with me for me and him to protect ourselves.
 f. ??Sam agreed with me for us to protect ourselves.

While judgments on these sentences may vary somewhat from speaker to speaker, different speakers are in agreement that (106) and (107) are not impeccable, as (105) is. Since optional transformations preserve sameness of grammaticality, Conjunct Movement cannot be a transformation.

The same type of argument can be made for sentences where the trace of an underlying subject in the surface form of the sentence is the so-called 'reflexive possessive' form one's own, and for cases where the possessive must necessarily be identical to the subject. Thus, while

- (108) Sam and I agreed to buy our own horseradish.

is perfectly grammatical, applying Conjunct Movement does not result in equally grammatical sentences.

- (109) a. *I agreed with Sam to buy our own horseradish.
 b. *Sam agreed with me to buy our own horseradish.
- (110) a. ??I agreed with Sam for $\left\{ \begin{array}{l} \text{him and me} \\ \text{me and him} \\ \text{us} \end{array} \right\}$ to buy our own horseradish.
 b. ??Sam agreed with me for $\left\{ \begin{array}{l} \text{him and me} \\ \text{me and him} \end{array} \right\}$ to buy our own horseradish.

Along the same lines, although

- (111) Sam and I agreed to watch our step.

is perfectly grammatical, the same does not hold for the sentences that result from applying Conjunct Movement to the structure underlying (111).

- (112) a. *I agreed with Sam to watch our step.
 b. *Sam agreed with me to watch our step.
 c. ??I agreed with Sam for $\left\{ \begin{array}{l} \text{him and me} \\ \text{me and him} \\ \text{us} \end{array} \right\}$ to watch our step.
 d. ??Sam agreed with me for $\left\{ \begin{array}{l} \text{him and me} \\ \text{me and him} \\ \text{us} \end{array} \right\}$ to watch our step.

Since the grammaticality of (111) is not preserved by Conjunct Movement, we must conclude that it is not a transformation.

While these facts show that Conjunct Movement does not preserve grammaticality of the structures it applies to, it is also necessary to note that if the deep structure of

(113) I agreed with Sam.

is something like

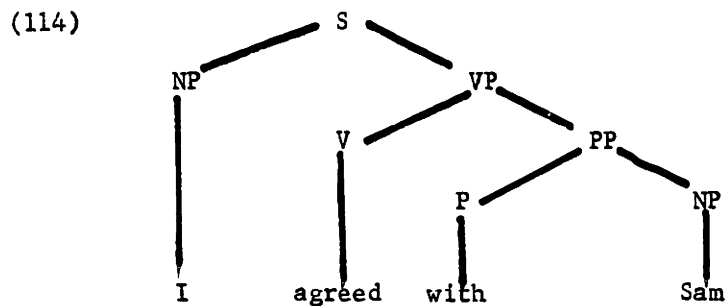

we would expect the following sentences to be grammatical.

- (115) *?I agreed with Sam to protect myself.
 (116) *?I agreed with Sam to buy my own horseradish.
 (117) *?I agreed with Sam to watch my step.

These sentences are certainly not grammatical. At present we have no explanation for this fact.

If there is no Conjunct Movement transformation, (114) must be the deep structure of (113). It might seem that by abandoning the Conjunct Movement transformation, we are forced to posit a new kind of deep structure, which we would not need if we kept the Conjunct Movement transformation. But even if there were a Conjunct Movement transformation, deep structures like (114) would be necessary anyway for sentences in which a noun phrase of the type that Warshawsky Harris (1965a, 1965b) has called 'picture nouns' occurs in the prepositional phrase. For example, the sentence

(118) I agreed with Sam's estimate.

must have a deep structure like (114). It cannot be derived from a deep structure like (78) because the resulting sentence

(119) *Sam's estimate and I agreed.

is ungrammatical. Therefore, abandonment of Conjunct Movement as a transformation does not force us to posit new kinds of deep structures that we would not need with the Conjunct Movement hypothesis.

It might be argued that the verb agree in (118) is a totally different verb from the agree in (76) and (85). The agree in (118) is certainly limited to a kind of stative meaning, while the agree in (76) and (85) seems to be ambiguous with regard to this property, as was remarked in footnote 7. However, it is not clear whether this difference in meaning may not be attributable to the presence of a 'picture noun;' if this is the case, it would not be necessary to posit two distinct verbs agree, alike in meaning except that one has an active reading in addition to the stative one, while the other has only the latter. Be this as it may, even if the agree of (118) is a separate verb from the other agree, it must occur both in deep structures like (78) and in deep struc-

tures like (91) and (114). Alongside (118) we have

(120) Sam's estimate and Ted's estimate agreed.

(118) can not be derived from a deep structure like (78) because of the ungrammaticality of *(119). Therefore, even if the agree of (118) is a different verb from the agree in (76) and (85), it still must occur in deep structures like (114). As a result, abandoning Conjunct Movement does not force us to postulate new deep structures that we would not need with the Conjunct Movement hypothesis.

Further evidence for deep structures like (114) comes from the fact that imperative sentences are possible with verbs that require NP* subjects.

(121) Confer with O'Hanrahan.

As we shall see in paragraph 2.3, imperative sentences require a second-person subject in deep structure. The grammaticality of (121) shows that confer must be able to appear in deep structure with a second-person subject, rather than only conjoined subjects. This is possible only if it occurs in deep structures like (114).

Another difficulty with the Conjunct Movement hypothesis is that it makes it necessary to resurrect Lakoff's notion of 'absolute exceptions.' Since sentences like

(122) *Pete and Tom resemble.

are ungrammatical, in order to derive sentences like

(123) Pete resembles Tom.

from deep structures with a conjoined subject like *(122), it is necessary to make Conjunct Movement obligatory with predicates like resemble, while it remains optional with most predicates. In the terminology of Lakoff (1965), it would be necessary to mark predicates like resemble

with a rule feature specifying that Conjunct Movement must apply. However, this rule feature is not sufficient, for if resemble occurs in deep structures like (78), and with the phrase structure rule (72) in the base component, deep structures like this one will be generated:

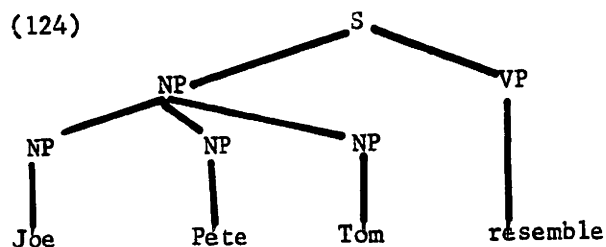

This deep structure does not underlie any well-formed sentences. Its output is ungrammatical:

(125) *Joe, Pete, and Tom resemble.

The rule feature that would make Conjunct Movement obligatory with resemble is of no help here, for Lakoff and Peters have shown that if there is a rule of Conjunct Movement, it must be constrained so as to apply only to binary conjoined structures. It therefore cannot apply to deep structures like (124) because its structural description is not met. In order to characterize sentences like *(125) as ungrammatical under the Conjunct Movement hypothesis, we must not only mark resemble with a rule feature that makes Conjunct Movement obligatory, we must also make it an 'absolute exception' to Conjunct Movement and require that the structural description of Conjunct Movement be met. To accept the Conjunct Movement hypothesis, then, is to have to fall back on the device of 'absolute exceptions.'

If we succeed in showing here that the like-subject constraint and the unlike-subject constraint are deep structure constraints, it follows that they are not 'absolute exceptions' to the Equi-NP Deletion transformation. The question then arises of whether absolute exceptions

are to be included among the devices provided by linguistic theory for use in the grammars of natural languages. The most striking thing about the notion of absolute exceptions is the fact that no evidence has ever been presented to show that significant generalizations are captured by treating any grammatical phenomena as absolute exceptions. Since the device of absolute exceptions seems to be otherwise unmotivated, the fact that the Conjunct Movement hypothesis forces us to use absolute exceptions makes that hypothesis itself suspect. Since there are other grounds for rejecting the Conjunct Movement hypothesis, we are spared the necessity of resorting to absolute exceptions.

If we return now to the arguments which Lakoff and Peters advance in support of the Conjunct Movement hypothesis, we find that in each case they are without foundation.

Lakoff and Peters point out that in

(126) John killed a man with Bill.

Bill is understood as having killed someone, while in

(127) John was killed with Bill.

Bill is understood as having been killed. Assuming this to be a question of grammatical relations, Lakoff and Peters argue that whether a given phrase object of with in surface structure is understood as subject or object of the verb is predictable if the with-phrase is derived from a conjoined noun phrase in subject position after application of the passive transformation. (126) would therefore be derived from the structure underlying

(128) John and Bill killed a man.

while (127) would be derived from the structure underlying

(129) John and Bill were killed.

The rule of Conjunct Movement would be ordered so as to follow the passive transformation, so that the fact that Bill is understood as having killed someone in (126) and as having been killed in (127) would follow from the grammatical relations in their source sentences - (128) and (129) respectively.

This analysis seems to be incorrect in two respects. First, it assumes that the noun phrase in the with-phrase participates in grammatical relations with the verb. For example, in

(130) John left with Bill.

under the Lakoff-Peters analysis, Bill is the subject of leave in deep structure, thereby bearing the same grammatical relation to leave that John bears. But this assumption seems to be in error. Consider the sentence

(131) I ate chicken paprikas with Salvatore.

(131) does not entail that Salvatore ate chicken paprikas. He could have had boeuf bourguignon, paella valenciana, Chungking pork, chicken teriyaki, or chili dogs. Or he might have eaten nothing at all. In fact, he might have been singing arias from The Marriage of Figaro while I was gorging myself on chicken paprikas. We therefore cannot conclude that the noun phrase in a with-phrase bears any grammatical relations in deep structure.

Second, Lakoff and Peters state that the 'grammatical relations' of the with-phrase are predictable from the surface structure subject of the sentence after application of the passive transformation. (126) and (127) seem to support this assumption. However, there are other sentences which show this assumption to be false. For example, in

(132) Czechoslovakia will doubtless be invaded by the Soviets with the Poles and Hungarians.

the Poles and Hungarians are understood as invading Czechoslovakia in conjunction with the Soviets. Lakoff and Peters' claim that the 'grammatical relations' of the with-phrase are predictable from the derived subject after application of the passive transformation entails that (132) is synonymous with

(133) ?Czechoslovakia and the Poles and Hungarians will doubtless be invaded by the Soviets.

Since (132) and (133) are not synonymous, Lakoff and Peters' claim is untrue. In addition, if the with-phrase must arise as a result of Conjunct Movement, which must be constrained to apply only to subjects in sentence-initial position after the application of the passive transformation, then the with-phrase in (132) can simply not be accounted for under the Conjunct Movement hypothesis. The grammaticality of (132) therefore shows that the with-phrase does not arise through Conjunct Movement, and that the Conjunct Movement hypothesis is observationally inadequate. The chief error would seem to lie in the assumption that the with-phrase participates in grammatical relations in deep structure, with (131) shows to be incorrect.

Lakoff and Peters' second argument for Conjunct Movement attempts to account for the deviance of sentences like

(134) *John left with himself.

by deriving it from the structure underlying

(135) a. *John and John left.

b. *John and himself left.

Whatever the status of sentences like *(134) and *(135), it is clear that this argument evaporates once it is shown that the noun phrase in the with-phrase does not participate in grammatical relations in deep structure, and therefore cannot be a subject in deep structure. (131) shows this.

A third argument advanced by Lakoff and Peters for Conjunct Movement seeks to explain the ungrammaticality of sentences like

(136) *Joe is resembled by Bill.

by means of the fact that Conjunct Movement is ordered so as to follow the passive transformation (in order to account for the 'grammatical relations' of the with-phrase in (126) and (127)). The deep structure of *(136) would therefore be

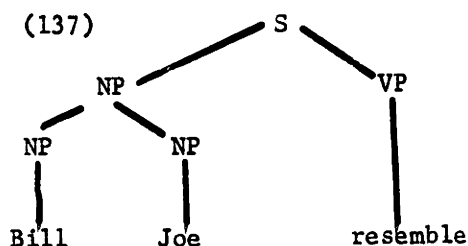

which is converted by Conjunct Movement into

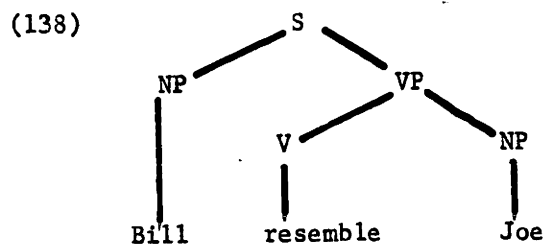

after the passive transformation has already applied. As a result, the passive cannot apply to (138), and the ungrammaticality of *(136) is accounted for. However, Dougherty (1968) cites examples of sentences which Lakoff and Peters would derive from NP* subjects by means of the Conjunct Movement transformation, to which the passive does apply.

(139) Pete's intelligence is equalled by his wisdom.

It is therefore clear that, whatever the reason for the ungrammaticality of *(136), it does not hold for all predicates which Lakoff and Peters postulate as undergoing Conjunct Movement. Dougherty's observation provides further evidence that the Conjunct Movement hypothesis is inadequate,

since if it derives the with-phrase in (127) by applying Conjunct Movement after the passive has applied, it can not account for the grammaticality of (139), while if it reverses the order to let Conjunct Movement precede the passive, it can not account for the with-phrase in (127).

Another argument advanced by Lakoff and Peters for Conjunct Movement is based on the claim that pairs of sentences like (74-77) and (83-86) are synonymous. As we have already seen, however, this claim is false.

Finally, Lakoff and Peters claim that the same selectional restrictions apply to the objects of prepositions in sentences like (83-85)¹⁰ that apply to the subjects of their respective predicates. However, we have already cited an example which shows that this claim is false. So-called 'picture nouns' can appear in the prepositional phrase, as in

(140) Rodney agreed with Clyde's estimate.

but they can not appear in subject position,

(141) a. *Rodney and Clyde's estimate agreed.

b. *Clyde's estimate agreed with Rodney.

unless the other noun phrases involved are also 'picture nouns:'

(142) a. Rodney's estimate and Clyde's estimate agreed.

b. Rodney's estimate agreed with Clyde's estimate.

It is the asymmetry between (140) and *(141) that is of interest here.

'Picture nouns' are free to occur in the prepositional phrase, but they can occur in subject position only if the other noun phrases involved are also picture nouns. Therefore it is not the case that the selectional restrictions on the prepositional phrase and the subject noun phrase are the same. As was remarked above, this holds even if the verb agree that occurs with 'picture nouns' is a different verb from the agree in

(76) and (85). The asymmetry between (140) and *(141) is sufficient to show that the selectional restrictions in deep structures like (78) are different from those in deep structures like (91) and (114).

It turns out, then, that the arguments that have been given in favor of the Conjunct Movement hypothesis do not stand up under closer scrutiny. At the same time, we have seen that there is a great deal of evidence against this hypothesis. Some of the data, particularly that in (100-117), is subject to unusual variation from one speaker to another, and any theory that does not account for this and the fact that judgments on some of these sentences are quite difficult to make is probably missing something significant. Positing the prepositional phrases of (83-85) as constituents in deep structure may be inadequate in this respect. But in the light of the evidence presented here, it is difficult to see how they could arise from Conjunct Movement. It is always conceivable, of course, that some other version of the Conjunct Movement theory might succeed where the one proposed by Lakoff and Peters (1969) fails, but until anything of the kind is shown, we must conclude that there is no Conjunct Movement transformation. As a result, the deep structure of (87) is not (90) but rather (92). In the deep structure (92), the like-subject constraint is satisfied. The grammaticality of such sentences is consequently not counterevidence to the claim that the like-subject constraint is a deep structure constraint.

2.2 The verb intend and the putative universality of the like-subject constraints

In languages such as Serbo-Croatian, in which Equi-NP Deletion is optional, and in languages like Bulgarian, which has no rule of Equi-NP Deletion at all, it is immediately apparent that the like-subject constraint

must be a deep structure constraint. In English there is no purely morphological evidence to show that the like-subject constraint is deep structural, and the existence of a number of apparent counterexamples to any such claim led linguists to assume that it was a transformational constraint. The fact that even in English deeper investigation has revealed that the constraint is deep structural makes one wonder whether similar investigation in other languages might not lead to the conclusion that the like-subject constraint is universal.

Another observation gives some substance to such speculation. This is the fact that by and large synonymous verbs in different languages manifest the like-subject constraint. Someone who is learning a totally unfamiliar language need not learn as a peculiarity of that language that the verbs which mean try, condescend, persuade, and force in that language manifest the like-subject constraint. If this is correct, the fact that certain verbs manifest the like-subject constraint need not be stated in the grammars of individual languages, but can be stated once and for all in linguistic theory. We might attempt a formulation something like:

- (143) If a given verb in one language manifests the like-subject constraint, then synonymous verbs in other languages also manifest the like-subject constraint.

(143) makes a very strong claim. This leads immediately to a far from trivial problem: how do we know when two verbs in different languages are synonymous? Unless we have some language-independent definition of synonymy, (143) is empty. The problem here is quite analogous to the kinds of problems that arose in phonology with respect to the question of how one can tell whether a /t/ in one language and a /t/ in another language are the 'same phoneme.' Such problems were resolved with the

advent of distinctive feature theory in phonology, which offered a universal definition, in terms of distinctive features, of the properties of which phonological segments are composed. Precisely the same kind of solution is needed for the analogous problem in semantics. We need a universal theory of semantic primitives and of the ways in which they are combined in lexical items. Given such a theory, the notion 'synonymous verbs in different languages' is defined and the fact that certain verbs manifest the like-subject constraint can be removed from the grammars of individual languages and stated in linguistic theory something like:

- (144) Verbs with certain bundles of semantic properties¹¹
manifest the like-subject constraint in all languages.

It would remain, of course, to give substance to the word certain in this definition by a precise statement of the semantic properties involved. If some such formulation as (144) turns out to be correct, it will constitute a case where the semantic properties of lexical items play a role in determining the types of deep structures they can appear in.¹²

It appears likely that the like-subject constraint is universal, that some statement along the lines of (144) will have to be incorporated into linguistic theory, and that this statement will predict which verbs in particular languages manifest the like-subject constraint. Such a claim can not be made with confidence at this time, however, because there are numerous apparent counterexamples to it. For example, we saw in Chapter One that the verb namjeravati 'intend' in Serbo-Croatian manifests the like-subject constraint, giving us paradigms like

- (145) a. Namjeravam da idem.
'I intend that I go.'

- b. *Namjeravam da ideš.
'I intend that you go.'
- c. *Namjeravam da Ana ide.
'I intend that Ana go.'
- (146) a. *Namjeravaš da idem.
'You intend that I go.'
- b. Namjeravaš da ideš.
'You intend that you go.'
- c. *Namjeravaš da Ana ide.
'You intend that Ana go.'

If some such formulation as (144) is correct, then verbs meaning 'intend' in all languages should manifest the like-subject constraint. English, however, is apparently a counterexample, for in English the full paradigms are grammatical.

- (147) a. I intend to go.
b. I intend for you to go.
c. I intend for Ana to go.

In view of these facts, it would appear that (144) is incorrect. One might attempt to modify it somewhat as follows:

- (148) Verbs with certain bundles of semantic properties may manifest the like-subject constraint in all languages, but whether a particular verb actually does manifest this constraint must be stated individually for each such verb in each language. Other verbs (i.e. verbs which do not have the requisite semantic properties) do not manifest the like-subject constraint in any language.

While it is considerably weaker than (144), (148) still embodies a substantive claim about language.

Instead of weakening (144) to (148), one might instead conclude that there is no such universal principle at all, and that the grammars

of individual languages must state which verbs in the language manifest the like-subject constraint and which do not as a separate fact about each verb in each language. This theory imposes no constraints at all on which verbs can manifest the like-subject constraint in any language. It claims that whether or not a particular verb in a particular language manifests the like-subject constraint is an ad hoc fact about that verb.

It is the purpose of this paragraph to show that the fact that the English verb intend occurs in full paradigms like that of (147) is not sufficient reason to abandon the principle (144) entirely, or even to weaken it to (148). It is our aim to try to preserve (144) by showing how apparent counterexamples like the verb intend in English can be dealt with. While we cannot be certain that all apparent counterexamples in all languages can be dealt with in this way, the tack taken here should at least prove suggestive.

Evidence will be presented here to show that despite the apparent counterevidence of (147), the English verb intend is a like-subject verb. If this is correct, this verb is not a counterexample to the claim that any verb in any language which has this meaning is a like-subject verb. In other words, this evidence shows that intend, at any rate, does not invalidate the principle (144). The question at issue, then is whether, despite the grammaticality of (147b) and (147c), intend is a like-subject verb, like try, or a verb which can take any subject in the embedded sentence, like want; such verbs I will call 'any-subject verbs.' If the former is the case, we will have to seek some explanation of the grammaticality of (147b) and (147c).

In paragraph 2.1.1 we saw that like-subject verbs behave differently from any-subject verbs when there is a passivized sentence embedded

beneath them, and that this difference in behavior supports the hypothesis that with like-subject verbs there is an intervening sentence with a verb like let or get between the matrix sentence and the embedded sentence in deep structure. This accounts for the fact that while

(149) I wanted to be arrested by the police.

is synonymous with

(150) I wanted the police to arrest me.

sentences like

(151) I tried to be arrested by the police.

are quite different in meaning; the meaning of (151) is best paraphrased by sentences like

(152) a. I tried to let myself be arrested by the police.

b. I tried to get myself arrested by the police.

c. I tried to get arrested by the police.

If we put intend into sentences of this kind, we find that it behaves like the like-subject verbs like try, rather than like the any-subject verbs like want. The sentence

(153) I intend to be arrested by the police.

like (151), is best paraphrased by a sentence with an intervening sentence with let or get between intend and arrest.

(154) a. I intend to let myself be arrested by the police.

b. I intend to get myself arrested by the police.

c. I intend to get arrested by the police.

If the deep structure of (153) is to represent its meaning, then, it must be something like

(155)

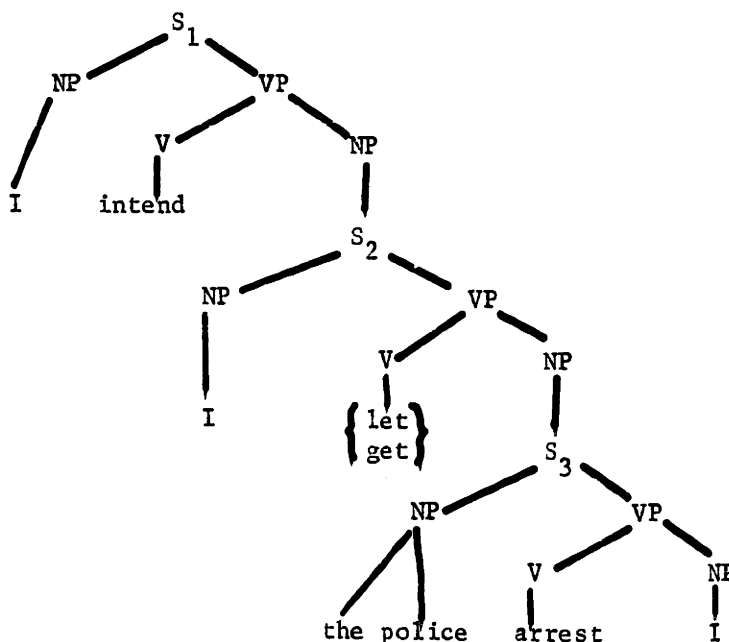

with an intervening sentence S_2 between the two sentences that show up in the surface form of (153). Because it posits this intervening sentence, the hypothesis whereby something like (155) is the deep structure of (153) will be referred to here as the 'intervening sentence hypothesis.' If this hypothesis is correct, then intend will have been shown to be behaving like a like-subject verb like try, since the deep structure of (151) is just like (155), the sole difference being that the main verb of S_1 is try rather than intend.

The intervening sentence hypothesis is easily verified, since all the arguments which support the existence of such an intervening sentence in the deep structure of sentences like (151) are equally applicable as support for something like (155) being the deep structure of (153).

First, recall that the sentence

(156) We were misunderstood.

is ambiguous. It has a stative or durative reading, as well as a reading on which a single act or incident of misunderstanding is meant. But

- (157) a. We let ourselves be misunderstood.
 b. We got (ourselves) misunderstood.

is unambiguous; only the second reading is possible. The fact that

- (158) We intend to be misunderstood.

is unambiguous in exactly the same way that (157) is follows automatically from the intervening sentence hypothesis.

Second, the same restriction that we saw earlier on what may be the deep subject of the lowest sentence shows up again when we have a passivized sentence beneath intend. Although

- (159) a. We were misunderstood by our friends.
 b. We were misunderstood by the public at large.
 c. We were misunderstood by Bill.
 d. We were misunderstood by Joe, Frank, Pete, Harry, and Mike.

are all grammatical, if we embed these sentences beneath let or get we find that

- (160) a. We let ourselves be misunderstood by our friends.
 b. We let ourselves be misunderstood by the public at large.

are perfectly grammatical, but

- (161) a. *We let ourselves be misunderstood by Bill.
 b. *We let ourselves be misunderstood by Joe, Frank, Pete, Harry, and Mike.

are somewhat strange. As the intervening sentence hypothesis predicts,

- (162) a. We intend to be misunderstood by our friends.
 b. We intend to be misunderstood by the public at large.

are all right, but

- (163) a. *We intend to be misunderstood by Bill.
 b. *We intend to be misunderstood by Joe, Frank, Peter, Harry and Mike.

are strange in the same way that *(161) is.

Third, intend does not embed a stative. This is the reason for the ungrammaticality of

(164) *We intend to know them as the Fugs.

But with a passive in the lower sentence the result is grammatical.

(165) We intend to be known as the Fugs.

This is correctly predicted by the intervening sentence hypothesis, since with deep structure like (155) the verb embedded beneath intend is not the stative know, but rather a non-stative like let or get, and so the constraint that intend may not embed a stative is not violated.

Fourth, the fact that manner adverbials which are fully grammatical with passive sentences such as

(166) a. I was cleverly examined by Dr. Cronkite.

b. I was intentionally examined by Dr. Cronkite.

cannot occur beneath let or get

(167) a. *I let myself be cleverly examined by Dr. Cronkite.

b. *I got (myself) cleverly examined by Dr. Cronkite.

(168) a. *I let myself be intentionally examined by Dr. Cronkite.

b. *I got (myself) intentionally examined by Dr. Cronkite.

with the intervening sentence hypothesis correctly predicts that such manner adverbials will be ungrammatical if (167) or (168) is embedded beneath intend.

(169) a. *I intend to be cleverly examined by Dr. Cronkite.

b. *I intend to be intentionally examined by Dr. Cronkite.

There is a variety of evidence, then, that the deep structure of sentences like (153) is something like (155), with the intervening sentence S_2 , and that intend consequently behaves like a like-subject verb

when there is a passivized sentence embedded beneath it whose derived subject has been deleted by Equi-NP Deletion. We can now extend this result by showing that there is also an intervening sentence of the postulated type in the deep structure of sentences like

(170) We intend for Lorraine to be misunderstood.

in which the derived subject of the embedded passive is not identical to the subject of the matrix sentence and therefor is not deleted by Equi-NP Deletion. Since the same arguments can be used to make this point that I have used above, the arguments will not be repeated here in full. The reader can refer back to what has preceded if he cannot reconstruct the arguments on the basis of what is given here.

First, although

(171) Lorraine was misunderstood.

is ambiguous, (170) is not. This follows from the non-ambiguity of sentences like

(172) We let Lorraine be misunderstood.

Second, the distribution of grammaticality in

- (173) a. We let Lorraine be misunderstood by our friends.
 b. We let Lorraine be misunderstood by the public at large.
 c. *We let Lorraine be misunderstood by Bill.
 d. *We let Lorraine be misunderstood by Joe, Frank, Pete, Harry, and Mike.

correctly predicts that in

- (174) a. We intend for Lorraine to be misunderstood by our friends.
 b. We intend for Lorraine to be misunderstood by the public at large.
 c. *We intend for Lorraine to be misunderstood by Bill.
 d. *We intend for Lorraine to be misunderstood by Joe, Frank, Pete, Harry, and Mike.

Third, intend cannot embed a stative. Therefore

(175) *We intend to know the group as the Fugs.

is ungrammatical. Since the intervening sentence hypothesis postulates another sentence between intend and know in sentences in which know is in the passive, it correctly predicts that

(176) We intend for the group to be known as the Fugs.

is a good sentence. In a deep structure like (155), know is not directly beneath intend, so that the constraint that intend cannot embed a stative is not violated.

Fourth, the ungrammaticality of

(177) *I let Morris be {cleverly
intentionally} examined by Dr. Cronkite.

correctly predicts that of

(178) *I intend for Morris to be {cleverly
intentionally} examined by
Dr. Cronkite.

In order to establish our point - that intend is a like-subject verb - we must now show that the presence of the intervening sentence in deep structure with intend is not a function of the presence of a passivized sentence in the complement, but rather holds whenever the embedded sentence appears to have a subject that is not identical to the subject of intend. We will now see that a wide range of syntactic facts is accounted for by a stronger version of the intervening sentence hypothesis than we have yet formulated: that the deep structures of all sentences of the form

(179) NP_i intends for NP_j to VP.

(where $NP_i \neq NP_j$) contain intervening sentences with a verb like let or get, similar to the intervening sentences we have postulated heretofore.

We can test this hypothesis most directly by determining whether the class of sentences that can occur embedded in sentences of the form

(179) is in any way restricted, and whether those restrictions are the restrictions that must in any event be imposed on the class of sentences that can be embedded beneath verbs like let and get. There is some evidence that this is in fact the case.

Sentences like

(180) There was a schism in the organization.

can be embedded beneath let and get.

(181) a. We let there be a schism in the organization.

b. We got there to be a schism in the organization.

Such sentences can also appear beneath intend in surface structure.

(182) We intended for there to be a schism in the organization.

Now, if (180) is embedded in the subject of threaten, we get a grammatical sentence.

(183) There threatened to be a schism in the organization.

But (183) can not be embedded beneath let or get.

(184) a. *We let there threaten to be a schism in the organization.

b. *We got there to threaten to be a schism in the organization.

If the intervening sentence hypothesis is correct, (183) should not be able to appear beneath intend in surface structure.

(185) *We intended for there to threaten to be a schism in the organization.

The prediction is empirically correct.

The intervening sentence hypothesis also makes correct predictions in a case involving a strange restriction on the application of the passive transformation. We have grammatical sentences like

(186) Tom prevented a tragedy.

which can be embedded beneath let and get

(187) a. We let Tom prevent a tragedy.

b. We got Tom to prevent a tragedy.

and can consequently appear beneath intend in surface structure.

(188) We intended for Tom to prevent a tragedy.

But if (186) is embedded beneath let or get, it cannot undergo the passive transformation. Although

(189) A tragedy was prevented by Tom.

is grammatical by itself,

(190) a. *We let a tragedy be prevented by Tom.

b. *We got a tragedy prevented by Tom.

is ungrammatical. As the intervening sentence hypothesis predicts, (189) can not appear beneath intend in surface structure.

(191) *We intended for a tragedy to be prevented by Tom.

As we have noted, intend does not embed statives. Although

(192) We knew them as the Fugs.

is perfectly grammatical, as a consequence of this constraint

(193) *We intended to know them as the Fugs.

is not. However, note that

(194) They intended for us to know them as the Fugs.

is grammatical. This follows automatically from the intervening sentence hypothesis, which posits an intervening sentence between the intend sentence and the know sentence, so that the know is not directly beneath intend and the constraint on intend not being able to embed a stative is not being violated.

There is a variety of evidence, then, which leads us to conclude that the intervening sentence hypothesis is correct.

It is worth noting here that the intervening sentence hypothesis brings with it at least two unsolved problems. The existence of these problems in no way undermines the intervening sentence hypothesis, however, for only another hypothesis which explains the facts that it does and in addition solves the remaining unsolved problems would do that. These unsolved problems therefore should be taken as an indication of some facts that any further research on this topic should take cognizance of.

The first problem concerns the identity of the main verb in the intervening sentence we have posited in the deep structure of those sentences where intend ostensibly embeds a sentence whose subject is not identical to its own. We have shown that if this verb has some of the syntactic properties of let and get a number of otherwise idiosyncratic facts about sentences with intend are automatically accounted for. The difficulty with postulating that the main verb of the intervening sentence is actually let or get is a semantic one. While the deep structure of sentences like

(195) I intend for Pat to go.

must, for both syntactic and semantic reasons, contain an intervening sentence of the kind we have postulated, (195) is not strictly synonymous with either

(196) I intend to let Pat go.

or

(197) I intend to get Pat to go.

If it is the deep structures of sentences that determine their semantic interpretation, as current linguistic theory postulates, then the structure underlying (195) cannot be the same as that underlying (196) or (197).

But we have seen that there must be some such intervening sentence in the deep structure of sentences like (195), and that the main verb of that sentence must have the same syntactic properties as let and get. What, then, is the main verb of the intervening sentence?

Our ability to give an answer to this question seems to depend on the kind of devices that linguistic theory makes available for use in the grammars of particular languages. In particular, one could use the notion of pro-verb, and posit that a pro-verb that has the same syntactic features as let and get but has no overt phonological shape is in fact the main verb of the intervening sentence in the deep structure of sentences like (195). If the grammars of natural languages are in fact subject to the kind of constraints on the recoverability of deletion discussed in Katz and Postal (1964) and Chomsky (1965), then the intervening verb's being a pro element would explain why it is freely deletable, resulting in the grammaticality of sentences like (195) and the others we have been discussing. However, any use of the notion of pro-verb in grammars must await compelling evidence which shows that linguistic theory must make this notion available for use in the grammars of particular languages, and to date no such compelling evidence has been forthcoming. The evidence presented here on the passive apparent counter-examples to the deep-structurehood of the like-subject constraint in paragraph 2.1.1 and the evidence for the intervening sentence hypothesis presented here in paragraph 2.2 may contribute toward this end, but at present this issue must be considered to be unresolved. If the notion of pro-verb is incorporated into linguistic theory, then the main verb of the intervening sentence in the deep structure of sentences like (195) is probably a pro-verb with the same syntactic features as let and get;

we might tentatively term this the 'causative pro-verb.' If the notion of pro-verb is not incorporated into linguistic theory, then the problem of the identity of the main verb of the intervening sentence in such cases remains as an unsolved problem.

Some recent discussion has interpreted the need to postulate a pro-verb as a *reductio ad absurdum* of any analysis which led to the need for such a device. While it is conceivable that this view is correct, it cannot be correct a priori. The question of whether or not grammars make use of pro-verbs, like all other such theoretical questions in any science, is at bottom an empirical issue. The question of whether or not the notion of pro-verb is to be incorporated into linguistic theory must be decided on the basis of empirical evidence.

One concrete criticism of the notion of pro-verb deserves specific mention. It has been claimed that if grammars can contain lexical items which never show up in the surface forms of sentences, then there is no limit on what one can postulate. If this were true it would be a valid criticism of pro-verbs, for under those circumstances linguistic theory would be failing to constrain the notion 'grammar of a human language' adequately. If, on the other hand, there exists a small universally defined set of 'possible pro-verbs' which the grammars of particular languages may make use of, then this criticism loses its sting. To determine whether this is actually the case, or indeed whether there is sufficient evidence to warrant incorporating the notion of pro-verb into linguistic theory at all, is clearly beyond the scope of this work. These points have been mentioned here only because they are tangentially relevant to the problem of determining the identity of the main verb of the intervening sentence we have postulated.

The other central problem which results from our demonstration that intend is a like-subject verb in deep structure arises when we compare the grammaticality of (195) with the ungrammaticality of

(198) *I tried for Pat to go.

If both try and intend are like-subject verbs in deep structure, to what is this difference due? We have already proposed an answer to the question of why (195) is grammatical: because its deep structure contains an intervening sentence of the kind we have discussed. The relevant question to ask, then, is one of the following:

(199) Why can intend embed an intervening sentence of the kind we have been discussing, while try can not?

or

(200) Why is the intervening sentence deletable beneath intend but not beneath try?

(199) is the appropriate question if try can not embed such an intervening sentence, while (200) is appropriate if it can. The issue is further complicated by the fact that try in fact does embed such an intervening sentence which undergoes deletion, in sentences like 'I tried to be arrested,' where the lowest sentence undergoes the passive transformation. I have made no attempt to investigate these questions either to determine which is the relevant question or to provide an answer to it. This must be left for future research.

It has been my purpose here merely to provide some evidence for the intervening sentence hypothesis and thereby to show that, despite the apparent evidence of sentences like (147b), (147c), and (195) to the contrary, intend is really a like-subject verb in deep structure. The English verb intend thus turns out to manifest the like-subject constraint, just as its Serbo-Croatian counterpart namjeravati does. Intend, ~~is~~ there-

fore not a counterexample to the principle (144), which states that whether or not a particular verb in a given language manifests the like-subject constraint is predictable on the basis of certain semantic properties of the verb. We can not be said to have demonstrated the correctness of this principle, for we have not even discussed what the relevant semantic properties are. What we have shown is that the grammaticality of sentences like (147b) and (147c) is not sufficient to overturn a principle like (144). While we cannot be sure that all apparent counterexamples to (144) in all languages can be dealt with in the same way, it should be clear that one should at least explore the possibility of some other analysis being able to account for apparent counterexamples before abandoning a principle like (144).

2.3 A deep structure constraint on imperative sentences.

The evidence that has been presented in this chapter to show that certain sentences with try and intend have sentences with a verb like let or get in their deep structures, even though these verbs do not appear in surface structure, also shows that imperative sentences require a second person subject in deep structure. Apparent counterexamples to this claim, such as

(201) Be arrested.

must have a deep structure like the ones which underlie

(202) Let yourself be arrested.

(203) Get (yourself) arrested.

That is, the deep structure of (201) must be something like

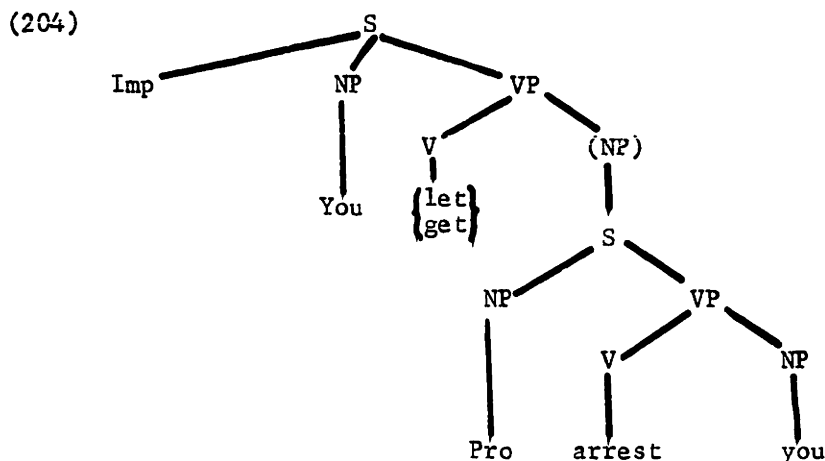

The syntactic arguments for this claim follow along the lines that have been given above.

First, note that imperatives like (201), in which you is apparently a derived rather than a deep structure subject, can not be formed with any verb. They are grammatical only with verbs which can be embedded beneath let and get. If we take a verb which can not, like rumor

(205) a. *I let myself be rumored to enjoy surfing.

b. *I got (myself) rumored to enjoy surfing.

we find that such verbs can not form passive imperatives like (201).

(206) *Be rumored to enjoy surfing.

This is an automatic consequence of passive imperatives like (201) having deep structures like (204).

Second, although

(207) You will be misunderstood.

is ambiguous, having a reading which refers to a single incident as well as a durative or stative reading.

(208) You will get (yourself) misunderstood.

has only the former reading. This is also true of

(209) Be misunderstood.

This, too, follows from the higher sentence hypothesis.

Third, stative verbs like know do not form imperatives.

(210) *Know them as the Fugs.

But if passive imperatives have a higher sentence in deep structure, with a second person subject and a verb like let or get, then statives like know should occur in passive imperatives, for let and get form imperatives without difficulty. The grammaticality of

(211) Be known as the Fugs.

therefore supports the higher sentence hypothesis.

Fourth, the inability of subject-selected manner adverbials like cleverly and intentionally to occur beneath let and get, as in

(212) *You let yourself be { cleverly
intentionally } examined by
Dr. Cronkite.

under the hypothesis that passive imperatives have deep structures like (204) correctly predicts that although

(213) Be examined by Dr. Cronkite.

is grammatical,

(214) *Be { cleverly
intentionally } examined by Dr. Cronkite.

is not.

What would otherwise be idiosyncrasies of the passive imperative are correctly predicted by the hypothesis under which passive imperatives have deep structures like (204). Passive imperatives are therefore another environment where the additional sentence with a verb like let or get must be posited in deep structure. Most important, this shows that the requirement that imperatives have a second person subject is not a transformational constraint, which would be satisfied if the subject is second person at the point in derivations at which the imperative transformation applies. Rather, imperative sentences must have a second person subject in deep structure.

Footnotes to Chapter Two

1. The NP-node dominating S_3 is parenthesized because it is not clear whether or not it is present. This does not affect the points at issue here one way or the other.
2. The distinction made here is a very subtle one. Many speakers are not sensitive to it, or the distinction is simply not made in their grammars. This fact is of course of no relevance to the theoretical points at issue, since no one can deny the theoretical relevance of data drawn from a language or dialect that he does not speak. Nonetheless, such speakers will fail to be convinced by arguments which rest on this distinction. So be it. The arguments which do not depend on this distinction are by themselves sufficient to show that (10) is the deep structure of (7).
3. For a discussion of the feature **[\pm Stative]** in English, see Lakoff (in press). The distinction between **[+ Stative]** and **[- Stative]** may actually be too gross; it seems to be necessary to make finer distinctions among different kinds of statives. The argument given here holds for those which cannot occur embedded beneath condescend.
4. We have shown that the subject of a sentence embedded beneath persuade must be identical to the object of persuade in deep structure. This constraint correctly discards as ungrammatical such sentences as

(i) *I persuaded the men for Francine to betray them.

But there are perfectly grammatical sentences like

(ii) I persuaded the men that Francine had betrayed them.

in which the subject of the embedded sentence is not identical to the object of the matrix sentence. We must therefore characterize the difference between sentences like (i), in which the like-subject constraint is operative, and sentences like (ii), in which it is not. Note first that (ii) has the that complementizer, while *(i) has the infinitival complementizer. In Chapter One we noted that in sentences in which the subject embedded beneath scream has the that complementizer the unlike-subject constraint is inoperative. Both phenomena may well be due to the same cause. Note also that the verb persuade in (ii) has a very different meaning from that of the verb persuade in *(i). It seems plausible that we are dealing with two distinct verbs here, both of which have the same phonological shape. If this is the case, it will suffice to mark one persuade in the lexicon as manifesting the like-subject constraint. However, we will not go into the question of how the difference between *(i) and (ii) is to be characterized. It suffices to have pointed out the distinction between the two kinds of sentences.

5. These facts from Dutch and their implications for deep structure constraints are pointed out by Kraak (1967).

6. This sentence is grammatical if it is understood with a deleted object, such that it would mean roughly: Joe agreed with someone (or something) and Bill agreed with someone (or something). This sentence with this reading might therefore arise as a result of object deletion of the kind discussed by Katz and Postal (1964), pp. 79-84 and Chomsky (1965), p. 87. Now, the sentence (76) seems to be ambiguous. On one reading it is synonymous to (81) in the sense just pointed out, and might arise from it by a rule of Conjunction Reduction along the lines discussed in Ross (1967). (76) has another reading, however, which seems to be the primary one. On this reading it is roughly paraphrasable by: Joe and Bill agreed with each other. It is this reading of (76) which is of interest here, and which differs in meaning from (81). (76) with this reading can not be derived from the structure underlying (81) because of this difference in meaning. It is because (81) can not have this reading of (76) - the one that is of interest here - that I have starred it.
7. Verbs like agree seem to be systematically ambiguous as between an active and a stative meaning. On the active reading, the subject in each case actually performs an act or action of agreeing. This is the reading under discussion. On the stative reading of these sentences, the subject may not have done any agreeing at all; in such cases the verb is used by the speaker to describe a state in which, for example, the statements of one person are in agreement with those of another.

8. These sentences are not synonymous to (100), which is the reason they are starred. They might be possible on the reading discussed in footnote 6, on which (102a) might be paraphrased roughly as: I agreed with Sam that I would disagree with someone (or something), but this reading is of no relevance to the point under discussion here.
9. There is also other evidence that if Conjunct Movement is a rule, it can not be a post-cyclical rule. It is the output of Conjunct Movement that must undergo successive applications of the Passive and It-Replacement transformations in the manner described in Lakoff (1966) in order to produce sentences like Sam was expected by Tom to have been believed by Sally to have agreed with Louise.
10. The same holds for the object of the verb in (86).
11. For the present discussion it is irrelevant whether semantic properties are conceived of in terms of semantic features, markers, or predicates.
12. Kiparsky and Kiparsky (1968) argue that factives constitute such a case.

CHAPTER THREE

The Two Verbs 'Begin'

In the current theory of syntax there are two ways available to represent the deep structure of sentences like

- (1) Zeke began to work.

begin might be an intransitive verb like seem and happen, which take abstract (sentential) subjects in deep structure, so that the deep structure of (1) would be something like

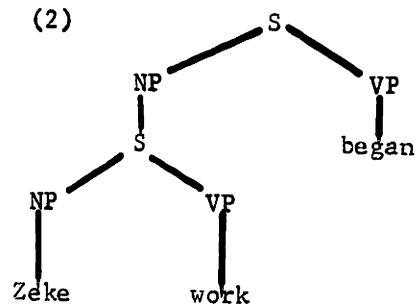

with the subject noun phrase Zeke being raised to subject position in the matrix sentence and the rest of the embedded sentence being moved to the right and brought under the domination of the matrix verb phrase,¹ yielding the correct derived constituent structure of (1).

On the other hand, begin might be a verb like try, which takes object complements. Since there are no sentences like

- (3) *Zeke began for Oscar to work.

begin, like try, condescend, and refuse, would manifest the like-subject constraint, requiring that the subject of the embedded sentence be identical to the subject of the matrix sentence in deep structure. Under this analysis the deep structure of (1) would look something like

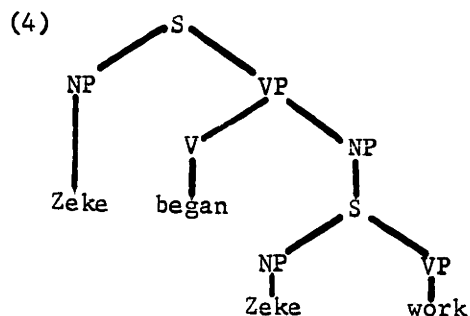

Equi-NP Deletion and other transformations which apply in the derivation of sentences with try and like verbs would apply here as well to produce the correct surface structure of sentences like (1).

In this paper evidence is presented to show that begin occurs in both types of structures in deep structure.

There is a variety of evidence that begin occurs in deep structure as an intransitive verb which takes abstract subjects, as in (2).

First, we note that it takes nominalized sentences as subject in such sentences as

(5) The doling out of emergency rations began.

begin must occur in deep structures like (2) if sentences like (5) are to be accounted for.

The second piece of evidence that begin is an intransitive verb like seem comes from consideration of sentences like

(6) There began to be a commotion.

Sentences like (6) would be impossible if begin occurred only in structures like (4), for to generate them from such structures it would be necessary for there to be the subject of begin in deep structure, but there is independent evidence that there is not present in deep structures at all, but rather is introduced by a transformation.² If, on the other hand, begin occurs in deep structures like (2), sentences like (6) are easily accounted for. The there-insertion rule applies in the embedded sentence, producing a structure like

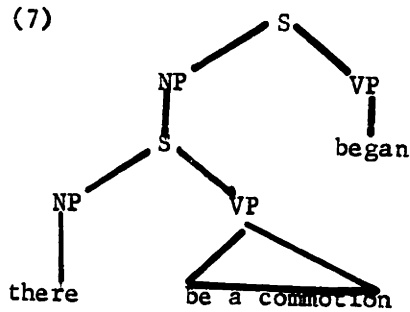

On the second cycle, there is raised to subject position in the matrix sentence, while to be a commotion is brought to the right of began and under the domination of that verb phrase.

A third piece of evidence for the existence of deep structures like (2) comes from sentences like

(8) It began to rain.

in which the dummy subject it of weather verbs like rain occurs as the surface subject of begin. If begin occurred only in deep structures like (4), we would have to postulate this dummy it as the deep subject of begin. If begin occurs in deep structure like (2), the embedded subject will be the sentence it rain and the correct surface structure will result automatically from rules that are independently motivated.

Fourth, we note the synonymy of the sentences

(9) a. The noise began to annoy Joe.

b. Joe began to be annoyed by the noise.

If these sentences were derived from deep structures like (4), we would expect them to exhibit some difference in meaning, since the deep subject of (9a) would be the noise, while that of (9b) would be Joe. With a deep structure like (2), however, (9a) and (b) have the same deep structure and differ only in that the passive transformation has applied in the embedded subject of (9b) but not in (9a). Their synonymy is thereby accounted for.

A stronger argument of this type for the existence of deep structures like (2) can be based on the distributional properties of lexical items like recourse, heed, and headway. These lexical items are not freely occurring nouns; we must exclude such sentences as

(10) a. *I like recourse.

b. *Recourse is nice.

and many others. The restriction on the occurrence of these nouns can be stated as follows: in deep structure they occur only in the fixed phrases have recourse (to), pay heed (to), and make headway.³ Note that recourse, heed, and headway must be dominated by an NP node in these fixed phrases, since the passive transformation, which refers to NP, can apply to them to produce such sentences as⁴

(11) Recourse was had to illegal methods.

(12) Heed was paid to urban problems.

(13) Headway was made toward a solution.

Now, since recourse, heed, and headway occur in deep structure only in the fixed phrases have recourse, pay heed, and make headway, they can not be the subject of begin (or of any other verb) in deep structure. This being the case, if begin occurred exclusively in deep structures like (4), there would be no way to account for the grammaticality of sentences like

(14) Recourse began to had to illegal methods.

(15) Heed began to be paid to urban problems.

(16) Headway began to be made toward a solution.

If begin occurs in deep structures like (2), however, these sentences are automatically accounted for by rules that are independently motivated. The passive transformation, which applies to produce sentences

like (11), will apply in the embedded sentence, yielding a derived structure like

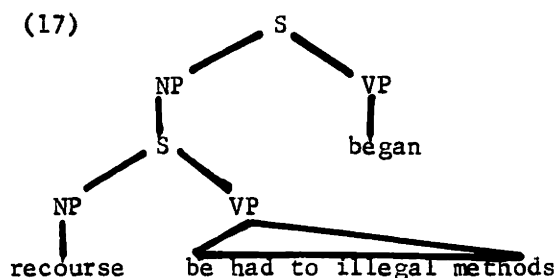

On the second cycle, the noun phrase recourse is raised to subject position in the matrix sentence, bringing the rest of the embedded sentence to the right of began and under the domination of that verb phrase. If begin occurs in deep structure like (2), the grammaticality of sentences like (14-16) is automatically accounted for.

There is abundant evidence, then, that begin occurs in deep structures like (2), in which it is an intransitive verb with an abstract (sentential) subject. We will now proceed to show that begin also occurs in deep structures like (4). The argument will proceed in several steps. First we will show that begin takes animate subjects in deep structure; this would be impossible if it occurred exclusively in deep structures like (2). Then we will see that begin occurs in sentences in whose deep structure it must have both an animate subject and a complement sentence, as it does in (4). Finally we will indicate the motivation for the NP node which dominates the complement sentence in (4).

That begin takes animate subjects in deep structure follows from the fact that it forms agentive nominalizations as in

(18) Pete is a beginner.

Verbs like seem and happen which take only abstract subjects in deep structure do not occur in such nominalizations.

- (19) a. *Pete is a seemer.
 b. *Pete is a happener.

There is also evidence that begin occurs in deep structures with both an animate subject and a complement sentence, as in (4). Recall that verbs like try, condescend, and refuse manifest the like-subject constraint, requiring that the subject of a sentence embedded directly beneath them be identical to their own subject in deep structure. For this reason the deep structure of sentences like

- (20) I tried to begin to work.

must be something like

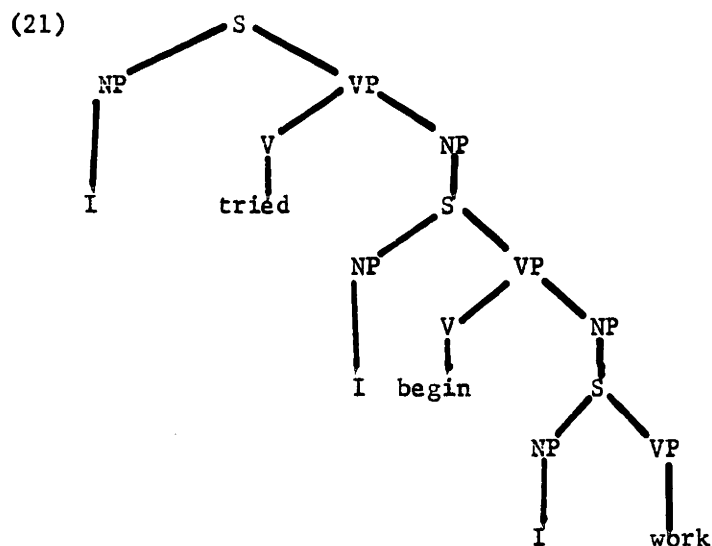

for the subject of the sentence beneath try must be identical to the subject of try in deep structure. If begin occurred exclusively in deep structures like (2), the deep structure of (20) would have to be something like

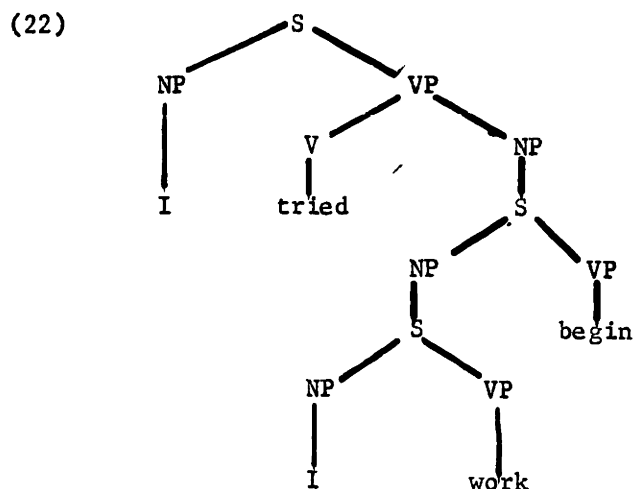

But in (22) the like-subject constraint is not satisfied, for the subject of the sentence beneath try is the entire noun phrase containing an embedded sentence and is therefore not identical to the subject of try. Since the like-subject constraint is not satisfied, an ungrammatical sentence must result. For this reason (21) rather than (22) must be the deep structure of (20). The grammaticality of (20) therefore shows that begin occurs in deep structures like (4).

A similar argument for deep structures like (4) is provided by the grammaticality of sentences like

(23) I forced Tom to begin work.

Since verbs like force require that the subject of a sentence embedded beneath them be identical to their own object in deep structure, the deep structure of (23) must be something like

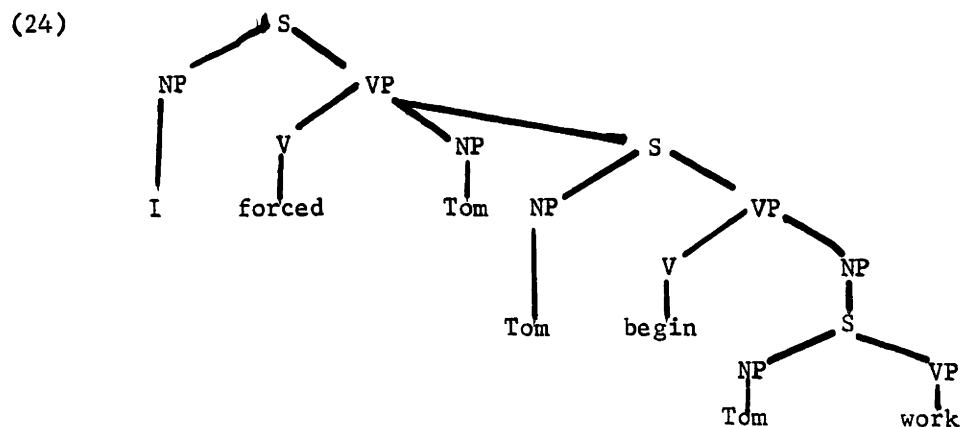

showing that begin occurs in deep structure with an animate subject and a complement sentence, as in (4).

Additional evidence for deep structures like (4) comes from imperative sentences like

(25) Begin to work.

Since imperatives require a second-person subject in deep structure, as we saw in Chapter Two, the grammaticality of sentences like (25) shows that begin takes animate subjects and complement sentences in deep structure, as in (4).

Let us now turn to the motivations for another aspect of deep structures like (4) - the NP node which dominates the embedded sentence. In this connection we notice that begin takes noun phrase objects, as in

(26) Sam began the job.

which predictably undergo the passive transformation.

(27) The job was begun by Sam.

If these sentences are to be accounted for, begin must take objects in deep structure.⁵

A slightly more intricate argument for the transitivity of begin in deep structure comes from such sentences as

(28) Mark began enthusiastically, but he got tired by noon.

Here begin occurs without an overt subject, and with a meaning like that of such verbs as eat and read when they have no overt object. If begin is a transitive verb, it can be marked for object deletion in the same way that eat and read are,⁶ and this behavior is thereby accounted for in the same way in all such cases. If we are to achieve this parallelism, however, begin must take objects in deep structure.

To summarize briefly, we have seen that on the one hand begin occurs in deep structures like (2), and that on the other it takes animate subjects and object complements, as in (4).⁷ We will call the former the intransitive begin and the latter the transitive begin. No grammar of English can be considered adequate unless it provides for the occurrence of begin in both types of deep structures.⁸

This conclusion raises several questions which we will merely mention here without giving a satisfactory answer to them.

The first question concerns what restrictions each begin imposes on its subject, the kind of complements it takes, and so on. For example, all verbs which manifest the like-subject constraint require animate subjects. Since sentences like *(3) must be ruled out as ungrammatical, the transitive begin must also manifest the like-subject constraint. We therefore expect the transitive begin to require animate subjects. This would mean that in all sentences in which the subject of begin in surface structure is inanimate we are dealing with the intransitive begin. That is, sentences like

(29) Oil began to gush from the well.

in which begin has an inanimate subject in surface structure, must derive from a deep structure like (2) rather than from one like (4). While we will not fully test this hypothesis here, there is some evidence that it is correct. Note that in sentences which we have showed to contain the transitive begin, the verb phrase beginning with begin can be replaced by do so.⁹

(30) Warren tried to begin to work and Jerry tried to do so too.

(31) I forced Warren to begin to work and Paul forced Jerry to do so.

(32) Begin to work and do so at once.

In sentences which contain the intransitive begin, however, the verb phrase beginning with begin can not be replaced by do so.

(33) *Heed began to be paid to urban problems and attention did so too.

(34) *There began to be a commotion and there did so at four o'clock.

This accords with a valid generalization about English: no verb which occurs in deep structures like (2) in which it takes abstract subjects can be replaced by do so. Now, if the transitive begin requires animate subjects and all sentences like (29) in which begin has an inanimate subject in surface structure are consequently instances of the intransitive begin, it should be the case that in such sentences the verb phrase beginning with begin can not be replaced by do so. This seems to be the case, since we do not get sentences like

(35) *Oil began to gush from the well and water did so too.¹⁰

While this is not conclusive, it can serve to illustrate the kinds of questions that need to be investigated in order to determine when we are dealing with the transitive begin and when the intransitive one.

The other major question that arises is that of the relation between the transitive and the intransitive begin. It has been the purpose of this paper to show that begin occurs in two distinct kinds of deep structures. The question of whether we are dealing with two distinct verbs, a single verb with two distinct sets of contextual features, or a single verb whose occurrence in these two kinds of deep structures is predictable in some way will be left open here.

The properties of begin that have been pointed out here are shared by such verbs as start, continue, keep, and stop, as well as

by verbs which at first glance would appear to be quite different. The verb threaten, for example, must be an intransitive verb that occurs in deep structures like (2) because the following sentences are grammatical:

(36) There threatened to be a riot.

(37) It threatened to rain.

On the other hand, it must occur in deep structures like (4) because these sentences are grammatical:¹¹

(38) I tried to threaten to resign.

(39) I forced Tom to threaten to resign.

(40) Threaten to resign.

The occurrence of threaten in both kinds of deep structure produces palpable ambiguities. For example, the sentence

(41) The students threatened to take over the administration building.

has two quite different readings. With the transitive threaten, it means that the students made threatening statements to the effect that they would take over the administration building. With the intransitive threaten in deep structure, (41) might be used to describe a scene in which a mob of students surged toward the administration building: on this reading it does not entail that anyone made any threats at all.¹²

The question of the range of verbs which are like begin in occurring as both a transitive and intransitive verb in deep structure, like the question of how the two verbs are to be related, if at all, will be left open here. It appears, however, that the phenomenon of transitive-intransitive verb doublets is quite widespread, and extends into the modal system. It has been observed by grammarians that modals like must, for example, are systematically ambiguous.¹³ A sentence like

(42) Clyde must work hard.

can express some obligation on the part of Clyde to work hard, or it can be paraphrased as: It must be the case that Clyde works hard. This suggests that must is a transitive-intransitive verb doublet like begin in deep structure, occurring in deep structures like (4) on the former reading and in deep structures like (2) on the latter. Vetter (1967) has shown that this is also the case with need. If these analyses are correct, and it turns out that there are syntactic facts in English which can be accounted for only if modals are transitive-intransitive verb doublets in deep structure, this will constitute evidence for the hypothesis argued in Ross (1967) that there is no 'Auxiliary' constituent in deep structure, and that the so-called 'auxiliary verbs' are real verbs in deep structure.

Footnotes to Chapter Three

1. For a justification of this formulation of Raising or It-
Replacement, see Lakoff (1966).

2. There behaves like a noun phrase with respect to transformational rules in that it inverts in questions (Was there a commotion?), shows up in tag questions (There was a commotion, wasn't there?), shows up with so (Joe said there would be a commotion, and so there was.), undergoes Raising (We expected there to be a commotion; There seems to be a misunderstanding.), and undergoes the passive transformation (There was expected to be a commotion.). But there cannot occur everywhere that noun phrases occur in deep structure; we must be able to rule out as ungrammatical such sentences as *I like there, *There is nice, and many others. It is difficult to see how this could be done if there occurs in deep structures. If there is introduced by a transformation, on the other hand, we can correctly rule out such deviant sentences by stating the constraints on the distribution of there on the rule that introduces it. We will now show that these constraints cannot be stated in deep structure, and must be stated by means of a transformational rule. There can occur only with a small number of intransitive verbs (such as be, in the examples already cited, and a few others, as in There ensued a controversy). There cannot occur with kill, for example, so alongside A policeman killed a demonstrator we do not get *There killed a policeman a demonstrator. Now, the passive transformation introduces be,

which can co-occur with there. And if the structure underlying A policeman killed a demonstrator has been transformed by the passive transformation into the structure underlying A demonstrator was killed by a policeman, which contains be, then the corresponding sentence with there is grammatical: There was a demonstrator killed by a policeman. Whether or not there can occur in such sentences cannot be determined on the basis of their deep structures alone, for their deep structures do not contain a verb with which there can co-occur. It is only if the passive transformation has applied, introducing be, that these sentences can contain there. In other words, the question of whether or not there can appear in certain sentences cannot be decided on the basis of their deep structures, but only after the passive transformation has applied. For this reason the constraints on the distribution of there cannot be stated in deep structure. We must conclude that there is not present in deep structure, but rather is introduced by a transformation.

3. Some speakers also allow the fixed phrase take heed (of). Note in passing that these fixed phrases can serve as indicators of environments in which particular verbs can be deleted. For example, Ray Dougherty has noted that although adverbials like by tomorrow cannot occur with verbs in the past tense (*We ordered a bicycle by tomorrow), sentences like We needed a bicycle by tomorrow are perfectly grammatical. This suggests that this sentence is derived from a deep structure with an additional verb in it: We needed to V a bicycle by tomorrow, in which by tomorrow is

not modifying needed, which is in the past tense, but rather the additional verb, which is not. On semantic grounds the appropriate verb would seem to be have, so that the sentence in question would be derived from the structure underlying We needed to have a bicycle by tomorrow by deletion of the verb have. Fixed phrases like have recourse (to) can be used to show that have is the correct choice here, since have must be able to undergo deletion in this environment anyway in order to account for the grammaticality of sentences like We needed recourse to some higher authority. This sentence must be derived from the structure underlying We needed to have recourse to some higher authority since recourse can occur only as the object of have. The two motivations for an underlying have in this environment explain the grammaticality of We needed recourse to some high authority by tomorrow.

4. This was pointed out by Chomsky to show the incorrectness of any analysis under which a passivized sentence like
- (i) The Mohawks were defeated by the Samoans.
- has a deep structure like

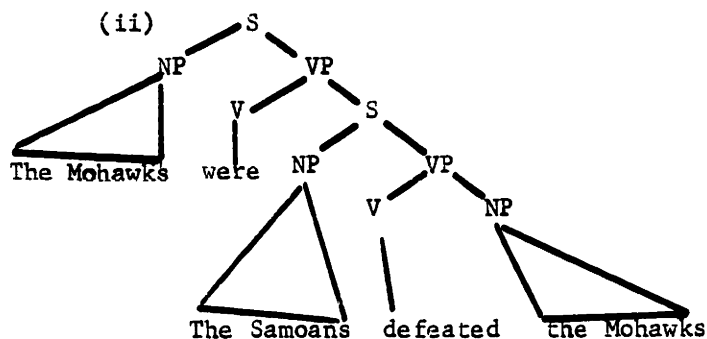

in which the surface subject of the passivized sentence (i) is the subject in deep structure of a higher sentence with the verb be. This analysis is incorrect, as (11-13) show, because re-course, heed, and headway occur in deep structure only in certain fixed phrases and therefore cannot be the subject of anything in deep structure. But the analysis of the passive under which (ii) is the deep structure of (i) would require recourse, heed, and headway to be the subject of be in the deep structures of (11-13). This analysis is therefore incorrect. (11-13) constitute extremely strong evidence that there is a passive transformation in English which takes deep structure objects and makes them into subjects in surface structure.

5. It might be argued that there are restrictions on the class of noun phrases that can be the objects of begin of a sort that make it necessary to derive these objects from more abstract underlying structures. Regardless of whether or not this is the case, they must still be dominated by an NP node, as is shown by their ability to undergo the passive transformation in sentences like (27).
6. For some discussion of object deletion of this kind and its relevance to semantic interpretation, see Katz and Postal (1964), pp. 79-84 and Chomsky (1965), p. 87.
7. We have shown that begin takes objects in deep structure, but strictly speaking, we have not shown that its complement sentences are object complements. That is, we have not shown that

a possible deep structure of (1) is not

(iii)

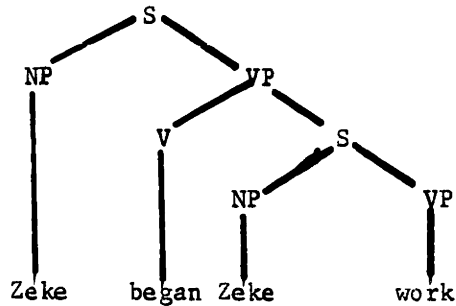

rather than (4). Since we have shown begin to appear in deep structures like

(iv)

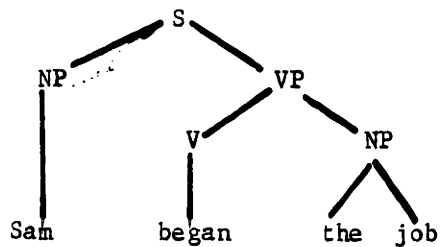

however, it is clear that phrase structure rules of the kind justified by Rosenbaum (1967) will produce deep structures like (4) anyway, since these phrase structure rules provide for noun phrase complementation by means of a rule that introduces S under NP. The question therefore is whether begin occurs in deep structures like (iii) in addition to deep structures like (4) and (2). The answer to this question may well turn out to be negative, even though sentences with begin fail to satisfy Rosenbaum's criteria for noun phrase complementation. The fact that we do not get passive sentences like *To work was begun by Zeke is irrelevant, as Robin Lakoff has pointed out, since even with verbs which normally passivize we do not get passives when the subject of the embedded sentences is identical to the subject of the matrix sentence. Thus expect, for example, takes object

complements and normally passivizes, yielding sentences like For Mike to win was expected by everybody. But if the matrix and embedded subjects are the same, no passive results *To win was expected by Mike. Since the begin that appears in structures like (4) or (iii) requires that the embedded subject be identical to the matrix subject, we will never get a passive like *To work was begun to Zeke. For this reason the lack of a grammatical passive here tells us nothing about whether begin takes object complements. George Lakoff has argued that the lack of grammatical pseudo-cleft sentences like *What Zeke began was to work is also not a valid argument against noun phrase complementation with such verbs, leading him to call into question the existence of intransitive verb phrase complementation, as in (iii). See Lakoff and Ross (in preparation) for these arguments. However this should turn out, it is only tangentially relevant to the point of this paper, which is to show that begin occurs both as a verb with abstract subjects, as in (2), and as a verb with animate subjects and complement sentences, as in (4) or (iii) or both.

8. Garcia (1967) points out that verbs like begin lack selectional restrictions on their subjects, and that sentences like (9a) and (9b) are synonymous. She concludes that on formal grounds begin should be treated as an intransitive verb that takes abstract (sentential) subjects, analogous to such verbs as seem and happen. She goes on to say that this solution does not accord with our intuitions about such sentences as John began to read the book

and offers this as a case where the formally motivated solution and the intuitively correct solution are in conflict. In this Chapter evidence has been presented to show that no grammar of English is adequate if it does not allow begin to occur in two distinct kinds of deep structures. As a result the issue raised by Garcia does not exist.

9. For discussion of do so, see Lakoff and Ross (1966). This topic is explored in considerably greater depth in Anderson (1968).
10. This sentence may be possible if did so is taken as having replaced gushed from the well, but did so can not have replaced began to gush from the well, which is the reading that is of interest here. For this reason I have starred the sentence.
11. Note that the threaten in (36-37) and the threaten in (38-40) are quite different in meaning.
12. I am indebted to Wayles Browne for pointing out (41) to me. Note in passing that there must be some additional constraints on sentences with threaten, for we do not get sentences like *Recourse threatened to be had to illegal methods.
13. Within a generative framework, the remarks of Hofmann (1966) are very suggestive.

PART TWO

CHAPTER FOUR

Evidence for Surface Structure Constraints in Syntax:

Object Pronouns in Spanish

4.0 Introduction

Standard grammars of Spanish point out that the object pronouns must come in a certain fixed order. For example, both Gili y Gaya (1961) and the Royal Spanish Academy (1931) state that when there is more than one object pronoun, the second person pronoun always precedes the first person, and either of these pronouns precedes the third person pronoun, and that the clitic pronoun se must precede them all.¹ Stockwell, Bowen, and Martin (1965) give a chart which is essentially equivalent to this statement.²

It is the purpose of this chapter to explore the implications of this well-known fact for linguistic theory.

In the theory of syntax of Chomsky (1965), deep structures generated by phrase structure rules into which lexical items have been inserted are mapped onto surface structures by grammatical transformations. The transformations perform a 'filtering function' in that the failure to apply of an obligatory transformation causes a derivation to block; such sentences are thereby characterized as ill-formed. To quote Chomsky:

Not all generalized phrase markers generated by the base will underlie actual sentences and thus qualify as deep structures. What, then, is the test that determines whether a generalized Phrase-marker is the deep structure of some sentence? The answer is very simple. The transformational rules provide exactly such a test, and there is, in general, no simpler test. A generalized Phrase-marker M_D is the deep structure underlying the sentence S , with the surface structure M_S , just in case the transformational rules generate M_S from M_D . The surface structure M_S of S is well formed just in case S contains no symbols indicating the blocking of obligatory transformations. A deep structure is a generalized Phrase-marker underlying some well-formed surface structure. Thus the basic notion defined by transformational grammar is: deep structure M_D underlies well-formed surface structure M_S . The notion 'deep structure' itself is derivative from this. The trans-

formational rules act as a 'filter' that permits only certain generalized Phrase-markers to qualify as deep structures.³

In this Chapter evidence is presented to show that in Spanish there are ungrammatical sentences which can not be characterized as such in a natural way by the blocking of obligatory transformations in the manner described above. It is necessary to strengthen grammatical theory by the addition of surface structure constraints or output conditions which the output of the transformational component must satisfy.⁴ In particular, it is shown that the fact that the object pronouns in Spanish must come in a certain fixed order must be stated by means of such a surface structure constraint. This constraint is to be interpreted as a template or filter that is applied to sentences generated by the transformational component. If the object pronouns in sentences generated by the transformations are in the correct order, the sentence is grammatical. If not, it is discarded as ungrammatical. It is shown that as a result of the surface structure constraint on object pronouns in Spanish, there are well-formed deep structures to which there correspond no grammatical surface structures.

The argument proceeds as follows. In Paragraph 4.1 we motivate the spurious se rule, which plays an important role in the evidence that follows. In Paragraph 4.2 it is shown that certain sequences of Spanish object pronouns always result in ungrammatical sentences. In order to prevent sentences with such pronoun sequences from being generated transformationally, it would be necessary to constrain more than one transformation to prevent each ungrammatical pronoun sequence from arising. In the case of one ungrammatical pronoun sequence - se se - it is shown that the kind of transformational constraint it would be

necessary to impose is unstatable in present theory, for this is in fact a surface structure constraint. It is therefore concluded that it is necessary to state an output condition that the output of the transformational component must meet. Sentences that fail to meet this output condition will be discarded as ungrammatical.

Paragraph 4.3 discusses the means by which this output condition is to be stated and proposes a notation to incorporate significant generalizations in the statement of this constraint. In Paragraph 4.4 it is shown that this constraint can not be stated transformationally, nor can the effect of this constraint be put into the phrase structure rules which generate deep structures. It is concluded that this constraint can be nothing other than a constraint on the output of the transformational component. In Paragraph 4.5 some of the theoretical implications of this result are discussed.

4.1 The spurious se rule.

In Spanish, object pronouns exist in both a 'strong' and a 'weak' or 'clitic' form. For readers who are unfamiliar with Spanish we give here a list of the object pronouns which will appear in what follows.

	<u>Strong Form</u>	<u>Weak Form Dative</u>	<u>Weak Form Acc.</u>
1st pers. sing.	mí	me	me
2nd person singular	tí	te	te
3rd person sing. masc.	él	le	lo
3rd person sing. fem.	ella	le	la
1st person plural	nosotros	nos	nos
3rd person plural masc.	ellos	les	los
3rd person plural fem.	ellas	les	las
3rd person reflexive (sg. & pl.)	sí	se	se

Only in the third person are the reflexive and non-reflexive forms of the pronouns distinguished. A handful of forms which will not be relevant to our discussion have been omitted.

The strong form of the object pronouns appears under emphasis and in positions of contrast as in

- (1) Elena no la vio a ella sino a él.⁵
 'Elena saw not her but him.'⁶

It also appears after prepositions:

- (2) Elena limpió la casa para él.
 'Elena cleaned the house for him.'

We will not be concerned here with the distribution of strong as opposed to weak forms of the object pronouns, but only with the weak or clitic forms.

As can be seen in (1), the strong forms of object pronouns (e.g., ella) follow the verb. This is also the case with non-pronominal objects.

- (3) Elena vio a Carmelina.
 'Elena saw Carmelina.'

The clitic pronouns, however, cannot stand after a finite verb, but must precede it.

- (4) a. *Elena vio (a) la.
 b. Elena la vio.
 'Elena saw her.'

The clitic pronouns may, however, follow an imperative, gerund, or infinitive, and they may move up from lower sentences. They may thus appear in any of several possible positions, as in the following example:

- (5) a. Jorge quería seguir gritándomelo.
 b. Jorge quería seguirmelo gritando.
 c. Jorge me lo quería seguir gritando.

'Jorge wanted to keep on shouting it to me.'

in which the clitics me lo ('it to me') may appear in any of three positions. Since the fact that clitics may move up from lower sentences is not directly relevant to establishing the necessity for an output condition on clitic placement in Spanish, we will not motivate it here. These matters are discussed in greater detail in Browne, Hale, and Perlmutter (in preparation).

A set of facts which are, however, crucial to motivating the necessity for an output condition on Spanish object pronouns concerns certain occurrences of the clitic pronoun se. We saw in the chart above that se is the third person reflexive pronoun and has the strong form sí. However, a number of occurrences of se cannot be accounted for as weak forms of sí. We will now proceed to determine the origin of these instances of se.

In some sentences we have a choice between using the strong or weak form of a pronoun.

- (6) a. Lo recomendé a ti.
 b. Te lo recomendé.

'I recommended it to you.'

The weak form of the third person singular Dative pronoun is le. We find it, for example, in:

- (7) Le recomendé ese hotel.

'I recommended that hotel to him.'

But in sentences analogous to (6) we find:

- (8) a. Lo recomendé a él.
 b. *Le lo recomendé.
 c. Se lo recomendé.

'I recommended it to him.'

Instead of the expected le we find se. This happens whenever we have two third person pronouns - a Dative and an Accusative - regardless of the number and gender of the pronouns. In other words, the following combinations of pronouns never occur:

- (9) *le lo *le los *le la *le las
 *les lo *les los *les la *les las

In each case we find, instead of le or les, the pronoun se, which, to distinguish it from the reflexive pronoun se, I will refer to as 'spurious se.' These facts suggest that spurious se arises through the following rule:

- (10) Spurious se rule: (obligatory)

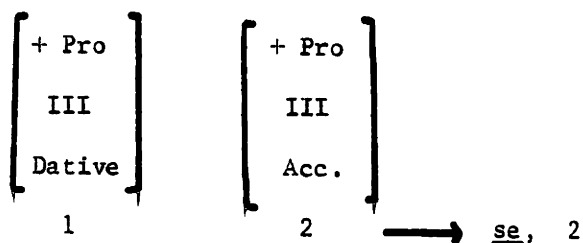

where 'III' simply means 'third person.'

This rule accounts for the fact that the pronoun sequences (9) do not occur, at the same time that it accounts for the appearance of spurious se. For what else could be the origin of this se?

Since se is the third person reflexive pronoun, we might be tempted to think that it arises through reflexivization. But note that (8c) means 'I recommend it to him.'⁸ No two noun phrases are identical, as is the

case in sentences with a reflexive pronoun. If we try to account for se in (8c) by means of reflexivization we must therefore revise the reflexivization transformation by relaxing the requirement of identity of reflexivizer and reflexivizee in just those cases where the reflexivized noun phrase is going to end up as a clitic in front of a third person Accusative pronoun. For spurious se appears only then. There is no grammatical sentence

(11) *Se recomendé ese hotel.

corresponding to (8c); we get (7) instead. To state such a condition on reflexivization, it would be necessary to refer to the presence of a third person Accusative clitic pronoun - a weird constraint to have to impose on reflexivization. Furthermore, genuinely reflexive instances of se can occur in the strong form sí accompanied by mismo for emphasis.

(12) a. Pedro se mató.

'Pedro killed himself.'

b. Pedro se mató a sí mismo.

'Pedro killed himself.'

But corresponding to (8c) there is no grammatical sentence with the strong form sí.

(13) *Se lo recomendé a sí mismo.

We must conclude that the se in sentences like (8c) does not arise through reflexivization.

There is further syntactic evidence that spurious se originates from a third person Dative pronoun, as the rule (10) would have it. We can see this in sentences in which the clitic pronouns are used redundantly - that is, we find a clitic pronoun in addition to a non-pronominal noun phrase or strong form pronoun. In such cases the clitic

pronoun must be the same person, number, and case as the full noun phrase of which it is a pronominal copy. This is the case in sentences with 'Dislocation,' in which a constituent has been preposed to the beginning of the sentence. Here the sentence must obligatorily contain a pronominal copy of a dislocated noun phrase.⁸

- (14) a. Luís se comió el pan.
 b. *El pan Luís se comió.
 c. El pan Luís se lo comió.
 'Luis ate up the bread.'⁹

Here the direct object has been dislocated, and we consequently have the Accusative pronoun lo obligatorily re-occurring in the sentence. Under Dislocation of the indirect object we find a Dative pronoun re-occurring obligatorily.

- (15) a. *A ella recomendé ese hotel.
 b. A ella le recomendé ese hotel.
 'I recommended that hotel to her.'

Now, if ese hotel has been pronominalized to lo we get:

- (16) a. Lo recomendé a ella.
 b. *A ella lo recomendé.
 c. *A ella le lo recomendé.
 d. A ella se lo recomendé.
 'I recommended it to her.'

It is clear that the redundant pronoun occasioned by Dislocation is se. Since the constituent that has been dislocated is Dative (cf. (15b)) and third person, spurious se must be derived from a third person Dative pronoun.

Looking at it from the opposite direction, we see that when we have spurious se the dislocated noun phrase may be any third person

noun phrase:

(17) A los bomberos que conocí en Nueva York se lo recomendaron.

'They recommended it to the firemen I met in New York.'

But it must be third person:

(18) a. *A ti se lo recomendaron.

b. *A mí se lo recomendaron.

c. *A nosotros se lo recomendaron.

All of these facts are automatically accounted for by the spurious se rule, which derives spurious se from a third person Dative pronoun.

Dislocation in fact strongly motivates the spurious se rule. We have noted the obligatory doubling of the pronoun in sentences with Dislocation. If spurious se had any origin other than that proposed here, sentences like (16c) and (17) with spurious se would constitute an exception to this generalization about Dislocation. One would have to account for the strange fact that whereas in general the redundant pronoun is obligatory under Dislocation, in just these cases the redundant pronoun can not appear at all, and instead this strange se obligatorily must appear. But these otherwise strange facts are automatic consequences of the spurious se rule, which is thus seen to be very heavily motivated. This is important, because this rule will play a crucial role in motivating the necessity for a surface structure constraint to account for the distribution of object pronouns in Spanish.

It now remains only to justify the formulation of the spurious se rule given in (10). We have already seen that only third person pronouns become se, and that that happens only before other third person pronouns. We have also seen that spurious se arises from a Dative pronoun. There are no grammatical sentences in which spurious se originates

from an Accusative pronoun.¹⁰ Hence the specification 'Dative' on the first term of (10). In all the cases we have seen, spurious se is followed by an Accusative pronoun. We have accordingly included the specification 'Accusative' in the second term of (10). However, since it seems that there are no possible sentences with the pronoun sequence le le on which we could test whether the first le becomes se, it might be possible to omit this specification.

4.2 Ungrammatical sequences of object pronouns in surface structure

We can now begin to examine the evidence that a surface structure constraint or output condition must be imposed on the output of transformations to block certain ungrammatical sequences of object pronouns in Spanish.

The verb escapar ('escape') can be used with two instances of the so-called 'Dative of Interest' or 'Ethical Dative' - one identical to the subject and hence reflexive, the other not - to mean roughly 'to escape from someone,' the 'someone' being the non-reflexive Dative of Interest. In this construction the reflexive pronoun must come first.

- (19) a. Te escapaste.
'You escaped.'
- b. Te le escapaste.
'You escaped from him.'
- c. Te me escapaste.
'You escaped from me.'
- d. Te nos escapaste.
'You escaped from us.'

However, if the subject is first person, the non-reflexive Dative con-

stituent cannot be te.

- (20) a. Me escapé.
'I escaped.'
- b. Me le escapé.
'I escaped from him.'
- c. *Me te escapé.
'I escaped from you.'
- (21) a. Nos escapamos.
'We escaped.'
- b. Nos le escapamos.
'We escaped from him.'
- c. *Nos te escapamos.
'We escaped from you.'

Since the reflexive pronoun must come first in this construction, *(20c) and *(21c) cannot be made grammatical by reversing the order of pronouns.

- (22) a. *Te me escapé.
b. *Te nos escapamos.

How is the grammar to characterize *(20c) and *(21c) as ungrammatical? It seems that we must impose a constraint something like:

- (23) A sentence with a second person Dative of Interest and a first person reflexive Dative of Interest is ungrammatical.

Now let us look at an entirely different construction - direct and indirect objects with verbs like recomendar ('recommend'). Pronominal indirect objects of such verbs may generally appear in either the strong form or the weak form.

- (24) a. Manuel quería recomendarte a mí.
b. Manuel quería recomendárteme.¹¹
'Manuel wanted to recommend you to me.'

But in some cases the pronoun may occur only in the strong form; putting it in the weak form results in an ungrammatical sentence.

(25) a. Manuel quería recomendarme a tí.

'Manuel wanted to recommend me to you.'

b. *Manuel quería recomendármete.

If we substitute the first person plural pronoun for the first person singular above we get analogous results.

(26) a. Manuel quería recomendarte a nosotros.

b. Manuel quería recomendártenos.

'Manuel wanted to recommend you to us.'

(27) a. Manuel quería recomendarnos a tí.

'Manuel wanted to recommend us to you.'

b. *Manuel quería recomendárnoste.

In order to rule out ungrammatical sentences like *(25b) and *(27b) it would be necessary to impose a constraint something like:

(28) The weak form of indirect object pronouns may not be used if the indirect object is second person singular and the direct object is first person.¹²

Comparing the constraints (23) and (28), we seen that the effect of both is to rule out sentences in which the pronoun sequences me te and nos te result. Furthermore, constraints (23) and (28) have no other motivation. To have to state these constraints, then, is to miss the generalization that regardless of their grammatical function, the presence of the pronoun sequences me te and nos te in surface structures causes the ungrammaticality of *(20c), *(21c), *(25b) and *(27b). It is generalizations of this kind, which cannot be stated deep structurally or transformationally, but only on the output of transformations, that we need to have some way of stating.

Continuing along similar lines, we find that while the sequence me le is fully grammatical, there are no grammatical sentences with the pronoun sequence le me.

In sentences with two non-reflexive instances of the Dative of Interest, there is no intrinsic reason why they should have to come in one order and not another. Yet we find only the order me le - never le me.

- (29) a. Mi chiquita está triste porque me le quitaron la muñeca.¹³

'My little girl is sad because they took her doll away (from her (on me)).'

- b. *Mi chiquita está triste porque le me quitaron la muñeca.

- (30) a. Me le hicieron mucho daño al auto.

'They did a lot of damage to my car.'

- b. *Le me hicieron mucho daño al auto.

- (31) a. Se me le cayó la piedra al anillo.

'The stone (la piedra) fell (se cayó) with respect to the ring (al anillo + le) on me (me) - i.e. the stone fell out of my ring.'

- b. *Se le me cayó la piedra al anillo.

We must somehow account for the fact that the sequence le me never appears in these constructions.

In the case of indirect objects of recomendar we also observe that the sequence le me never occurs, although we might well expect it to. The indirect object clitic pronoun can precede the direct object pronoun, as in:

- (32) a. Lo ocupé porque lo habían recomendado a mí.

- b. Lo ocupé porque me lo habían recomendado.

'I hired him because they had recommended him to me.'

Those informants who accepted the sequence te me in sentences with recomendar also accepted both of these sentences:

(33) a. Me ocupaste porque me habían recomendado a tí.

b. Me ocupaste porque te me habían recomendado.

'You hired me because they had recommended me to you.'

But when using the weak form of the pronoun results in the sequence le me, the sentence is ungrammatical.

(34) a. Me ocupó porque me habían recomendado a él.

'He hired me because they had recommended me to him.'

b. *Me ocupó porque le me habían recomendado.¹⁴

Here, then, where me is Accusative and le is Dative, the sequence le me is ungrammatical, just as it is in (29-31), where both me and le are Dative. We need to have some way of ruling out sentences with the pronoun sequence le me, regardless of their origin.

That it is necessary to rule out certain surface sequences of clitic pronouns can be seen in a particularly striking way in the case of the pronoun sequence se se, which has a number of opportunities of arising in Spanish. Yet it never does. We will now show that in order to block this ungrammatical pronoun sequence by constraining the transformations that would give rise to it, it would be necessary to refer to the output sequence se se itself; no other constraints on the transformations will suffice to rule out se se. Since we must refer to the output sequence se se anyway, it is clear that constraining the transformations themselves is completely beside the point. All we need to do is rule out the sequence se se in final output.

In addition to reflexive se and spurious se, there is a third source of se in Spanish. This kind of se I will call 'impersonal se,'

for it arises as the result of an underlying Pro subject, analogous to on in French and man in German.

(35) En Méx^o se trabaja mucho.

'In Mexico Pro ("one") works a lot.'

(36) Se me permiti^o dormir toda la mañ^a.

'Pro allowed (se permiti^o) me to sleep all morning,

i. e. I was allowed to sleep all morning.'

Impersonal se is the only way an underlying Pro subject can show up in surface structure. As we will see, this impersonal se behaves like a clitic pronoun in every respect.

Spanish also has a process which I will refer to as 'S-Pronominalization;' an S which is identical to a previous S in the sentence is replaced by the pronoun lo. As a result of these two phenomena we find sentences like

(37) A Sarita se le permiti^o dormir toda la mañ^a, pero a mí no se me lo ha permitido.

'Sarita was allowed to sleep all morning, but I wasn't allowed to.'

The lo here has replaced the sentence (yo) dormir toda la mañ^a (cf. (36) above). Recall that the repetition of the dislocated NPs (a Sari^a and a mí) in pronomial form (le and me, respectively) is obligatory.¹⁵

Now, to show that the pronoun sequence se se results in an ungrammatical sentence, let's try to reverse Sarita and mí in the deep structure of (37). We end up with an ungrammatical sentence.

(38) a. *A mí se me permiti^o dormir toda la mañ^a, pero a Sarita no se le lo ha permitido.

b. *A mí se me permiti^o dormir toda la mañ^a, pero a Sarita no se se lo ha permitido.

'I was allowed to sleep all morning, but Sarita wasn't allowed to.'

*(38a) is ungrammatical because the spurious se rule has not applied; we saw in Paragraph 4.2 that the sequence le lo is never grammatical. The spurious se rule has applied in *(38b) but the sentence is still ungrammatical - because we have ended up with the pronoun sequence se se. Finally, there is no low-level rule which converts the ungrammatical se se to se, since the sentence

- (39) *A me se me permitió dormir toda la mañana, pero
A Sarita no se lo ha permitido.

'I was allowed to sleep all morning, but he didn't
allow Sarita to.'

is not accepted. The second half of *(39) would be perfectly grammatical by itself, for example in

- (40) Ramón me permitió dormir toda la mañana, pero a Sarita
no se lo ha permitido.

'Ramón allowed me to sleep all morning, but he didn't
allow Sarita to.'

Since the indirect object must obligatorily be repeated in pronominal form, the se lo in the second half of *(39) and (40) is the result of le lo, due to application of the spurious se rule. This is fully grammatical in (40), since the subject is Ramón. But in *(39), where the Pro subject must be spelled out with se, the second half of the sentence cannot be interpreted as having a Pro subject, since the one se present is 'used up' in the role of spurious se derived from le.¹⁶ Thus the first half of *(39) has a Pro subject, while the second half, if it can be interpreted at all, is felt to contain a deleted non-Pro third person subject. *(39), then, has exactly the same status as

- (41) *A Sarita se le permitió dormir toda la mañana, pero
a mí no me lo ha permitido.

'Sarita was allowed to sleep all morning, but he didn't allow me to.'

The subject of the first half of the sentence is Pro, while the subject of the second half is a deleted non-Pro third person pronoun - hence 'he,' 'she,' or 'it' in English translation. This creates an imbalance which is the source of the non-acceptability of *(39) and *(41). While (37) is a fully grammatical sentence, if we interchange Sarita and mi in its deep structure we cannot obtain a grammatical sentence.

We must somehow characterize sentences like *(38b) as ungrammatical. The issue before us is how to do it. There are three possibilities:

- (a) Constrain optional transformations so that they do not apply and therefore do not produce sentences like *(38).
- (b) Cause an obligatory transformation to block, thereby characterizing the resulting sentence as ungrammatical.
- (c) Adopt a surface structure constraint which discards as ungrammatical any sentence with the pronoun sequence se se in surface structure.

The only optional transformation involved in the production of *(38b) that could conceivably be constrained in S-Pronominalization. If S-Pronominalization were prevented from applying in the derivation of this sentence, we would end up with the sentence:

- (42) A mi se me permitió dormir toda la mañana, pero a Sarita no se le ha permitido dormir toda la mañana.

'I was allowed to sleep all morning, but Sarita was not allowed to sleep all morning.'

While (42) might be clumsy or redundant, it is grammatical. So it is in principle possible to emerge with a grammatical sentence from the deep structure underlying *(38b), if S-Pronominalization is somehow

prevented from applying.

Now, how are we going to state the constraint that prevents S-Pronominalization from applying in the derivation of (42) so that *(38b) is not produced? We cannot constrain the application of S-Pronominalization in general, for it ~~has~~ applied in (37) and yielded a grammatical sentence. Since the difficulty in *(38b) seems to have been caused by the subsequent application of the spurious se rule, we might try to block S-Pronominalization in environments in which its application makes it possible for the spurious se rule to apply subsequently. However, it is useless even to consider such a constraint, for in (40) S-Pronominalization has applied, making it possible for the spurious se rule to apply subsequently, and a grammatical sentence has resulted. What causes the ungrammaticality of *(38b) is the fact that spurious se rule has applied in a sentence in which there is already a se present, resulting in the surface sequence se se. To prevent S-Pronominalization from applying in just this situation, we would have to have some way of specifying, at the point in derivations at which S-Pronominalization applies, the class of sentences that are potentially ungrammatical as the result of the application of subsequent rules and the class of sentences that are going to undergo later rules - both obligatory and optional - which produce some ungrammaticality as a result of the fact that S-Pronominalization had previously applied. This information is not available at the point at which S-Pronominalization applies. It is available only after all relevant transformations have applied. For the constraint that we must state is not a constraint on the operation of a particular transformation such as S-Pronominalization, but a constraint on the interaction of the output of S-Pronominalization with the output of other transformations. In short, it is not a transformational constraint but a constraint

on the output of the entire transformational component. The information we would need to block S-Pronominalization is available only after both S-Pronominalization and the spurious se rule have applied, at which point we can not prevent S-Pronominalization from having previously applied. It is clear, then, that we cannot prevent *(38b) from being generated by constraining the rule of S-Pronominalization.

The same kinds of arguments serve to show that we cannot characterize *(38b) as ungrammatical by causing an obligatory transformation to block. The only transformations that could possibly be relevant here are the spurious se rule, the rule that doubles the indirect object by placing a pronominal copy of it before the verb, and the rule that spells out the underlying Pro subject as the morpheme se. Picking one of these rules and saying that the derivation blocks if it applies would be perfectly arbitrary, and therefore unjustified. Furthermore, whichever of these rules we pick, we will encounter the same kind of difficulty we found in trying to constrain the rule of S-Pronominalization. If we try to make the spurious se rule block,¹⁷ for example, we will find ourselves stating the conditions under which it blocks something like this: The spurious se rule blocks a derivation if it results in the presence of the pronoun sequence se se in surface structure. This is not a constraint on a transformation, but a constraint on a resulting surface structure. To take a statement about surface structure, such as this one, and to make it a constraint on a transformation is to miss the relevant generalization completely. It is the resulting surface structure that causes the ungrammaticality.

We must conclude that constraining an optional transformation or causing an obligatory transformation to block is not the proper way of

characterizing the ungrammaticality of sentences like *(38b). Rather than constraining or blocking transformations, we will let them apply freely in sentences like *(38). We will then impose an output constraint which discards sentences with the pronoun sequence se se as ungrammatical.

There is a striking piece of additional evidence pointed out to me by George Bedell that this is, in fact, the correct solution. There is an optional rule whereby a sentence identical to a previous sentence in the relevant respects may be deleted.¹⁸ This rule applies to sentences like

- (43) A Sarita se le permitió dormir toda la mañana, pero a mí no se me lo permitió.

'Sarita was allowed to sleep all morning, but I wasn't allowed to.'

The rule in question deletes most of the second half of (43) to produce the sentence:

- (44) A Sarita se le permitió dormir toda la mañana, pero a mí no.

'Sarita was allowed to sleep all morning, but I wasn't.'

If we reverse Sarita and mí in the deep structure of (43), we get a sentence like *(38), whose ungrammaticality has been under discussion.

- (45) a. *A mí se me permitió dormir toda la mañana, pero a Sarita no se le lo permitió.
 b. *A mí se me permitió dormir toda la mañana, pero a Sarita no se se lo permitió.

'I was allowed to sleep all morning, but Sarita wasn't allowed to.'

However, if we apply the rule which deletes most of the second half of such sentences to the structure underlying *(45), a grammatical sentence results:

- (46) A mí se me peritió dormir toda la mañana, pero a Sarita no.

'I was allowed to sleep all morning, but Sarita wasn't.

This is striking confirmation of our claim that the ungrammaticality of *(38b) and *(45b) is due to the pronoun sequence se se in surface structure. When the part of the sentence containing this se se sequence has been deleted, the resulting sentence is perfectly grammatical. A surface structure constraint which discards sentences with the pronoun sequence se se as ungrammatical correctly predicts that *(38b) and *(45b) are ungrammatical and that (46) is not.

We will now proceed to show that the pronoun sequence se se in surface structure always results in ungrammaticality, regardless of how it arose:

In the sentence

- (47) Se les da los honores a los generales.

'Pro gives the honors to the generals,' ie. 'The honors are given to the generals.'

the repetition of the indirect object as les is obligatory. In sentences like this, if los honores is pronominalized to los, no matter what the reason for the pronominalization, an ungrammatical sentence will result. Thus we may say

- (48) A los generales se les da los honores, pero a los colimbas no se les da los honores.

'To the generals the honors are given, but to the draftees the honors are not given.'

but we may not follow the more natural course and pronominalize los honores.

- (49) a. *A los generales se les da los honores, pero a los colimbas no se les los da.

- b. *A los generales se les da los honores, pero a los colimbas no se se los da.

In *(49a) the spurious se rule has not been applied, while in *(49b) the pronoun sequence se se has resulted. The ungrammaticality of *(49b) is clearly due to the pronoun sequence se se, since if we delete the part of the sentence which contains it, the result is grammatical.

- (50) A los generales se les da los honores, pero a los colimbas no.

'To the general the honors are given, but to the draftees they are not.'

That the se se sequence which resulted from pronominalization of los honores to los and subsequent application of the spurious se rule is the cause of the ungrammaticality of *(49b) can also be seen in the fact that the same difficulty arises if we try to dislocate los honores in (47), thereby necessitating a repetition of los honores as the clitic pronoun los. It is then impossible to obtain a grammatical sentence.

- (51) a. *Los honores se les los da a los generales.
b. *Los honores se se los da los generales.

That this ungrammaticality is due to the resultant se se sequence is clear from the fact that if there is no impersonal al gobierno ('the government') for Pro as the subject of (45), there will be no impersonal se:

- (52) El gobierno les da los honores a los generales.

'The government gives the honors to the generals.'

Now it is possible to dislocate los honores:

- (53) Los honores el gobierno se los da a los generales.

since with no impersonal se present, the creation of spurious se does not lead to the ungrammatical pronoun sequence se se.

There are other sentences in which the pronoun sequence se se should arise, but they too are ungrammatical. For example, consider the case of verbs which must occur with a reflexive clitic pronoun. One such verb is enfermarse ('get sick').

- (54) a. *Cuando Sarita tiene frío, enferma muy pronto.
 b. Cuando Sarita tiene frío, se enferma muy pronto.

'When Sarita is cold, she gets sick pretty quick.'

*(54a) is ungrammatical because it lacks the reflexive pronoun se.

Now, suppose that the subject of (54b) is not Sarita but rather Pro.

Pro must be spelled out with impersonal se. For this reason no grammatical sentence can result.

- (55) a. *Cuando se tiene frío, se enferma muy pronto.
 b. *Cuando se tiene frío, se se enferma muy pronto.

'When "one" is cold, "one" gets sick pretty quick.'

*(55a) is ungrammatical because it feels like *(54a); the se in the main clause is 'used up' as impersonal se, to agree with the first clause, and there is no se left for enfermarse. *(55b) is ungrammatical because it contains se se.

If we attempt to characterize *(55b) as ungrammatical by causing some obligatory transformation in its derivational history to 'block,' we will have to arbitrarily pick one transformation and impose an ad hoc constraint on it to the effect that it 'blocks' under just those conditions which would lead to the occurrence of the pronoun sequence se se in surface structure. Since the conditions which lead to ungrammaticality are a property of the resulting surface structure, to attempt to characterize the ungrammaticality as a transformational violation is to miss the point. Since a surface structure constraint to rule out as

ungrammatical sentences with se se in surface structure is needed anyway, independently of *(55b), it is clear that the same constraint should be used to characterize *(55b) as ungrammatical. *(55b) is then an example of a sentence with a well-formed deep structure to which there corresponds no well-formed surface structure. Cases of this kind constitute strong evidence for surface structure constraints.

In this connection, we should note that although there are grammatical sentences which may seem extremely close to *(55b) in meaning, they are not in fact paraphrases of it and therefore could not have arisen from the same deep structure. Instead of *(55b) one might say:

(56) Cuando uno tiene frío, (uno) se enferma muy pronto.

'When one is cold, one gets sick pretty quick.'

using uno ('one') instead of Pro as the subject. However, uno is different in meaning from Pro. This difference shows up syntactically in sentences which require a plural subject.

(57) a. Se rodeó la casa.

'Pro surrounded the house,' i.e., 'The house was surrounded.'

b. *Uno rodeó la casa.

'One surrounded the house.'

(58) a. A las cinco se empezó a llegar.

'At five o'clock Pro began to arrive.'

b. *A las cinco uno empezó a llegar.

'At five o'clock one began to arrive.'

Since uno and Pro have different possibilities of occurrence, they can not be the same entity. Although (56) may seem to have the same meaning as *(55b), it can not have the same deep structure as *(55b). The fact remains that the deep structure underlying *(55b) is well-formed but

corresponds to no grammatical surface structure. A surface structure constraint is therefore necessary to discard *(55b) as ungrammatical.

Another case where we would expect the pronoun sequence se se to arise derives from sentences with a Pro subject and a Dative of Interest identical to the subject, which will then reflexivize and become reflexive se. The resulting sentence, with both impersonal se and reflexive se, will be ungrammatical. Thus alongside

(59) Cuando come, Manfredo se lava las manos antes.

'When he eats, Manfredo washes his hands beforehand.'

where the Dative of Interest shows up as reflexive se, we cannot have such a Dative of Interest with impersonal se deriving from an underlying Pro subject:

(60) a. *Cuando se come, se lava las manos antes.

b. *Cuando se come, se se lava las manos antes.

'When "one" eats, "one" washes one's hands beforehand.'¹⁹

While (60a) might be grammatical with a reading in which las manos are not "one's hands" but rather some plastic hands kept on a shelf (i. e. alienable rather than inalienable possession), it is ungrammatical as a realization of the deep structure which is identical to that underlying (59) except that Pro has been substituted for Manfredo in subject position. This is because there is only one se, while this deep structure would yield two - reflexive se stemming from the Dative of Interest and impersonal se. *(60b), on the other hand, is a correct realization of the deep structure in question, but is ungrammatical because it contains the pronoun sequence se se. It is like *(55b) in that here too a well-formed deep structure corresponds to no grammatical surface structure. Only a surface structure constraint can characterize such sentences as

ungrammatical.

There is abundant evidence, then, that the pronoun sequence se se in surface structure, no matter what its origin may be, causes the sentence to be ungrammatical. In this respect se se is like the pronoun sequences me te, nos te, and le me discussed earlier. We need to have some way of discarding as ungrammatical any sentence which contains one of these pronouns sequences in surface structure.

4.3 Developing a notation to state the constraint

We have found that a number of sequences of pronouns in surface structures always result in ungrammatical sentences, no matter which transformations had applied to produce them. We must therefore include in the grammar of Spanish a surface structure constraint to rule out certain outputs of the transformational component. The question now arises of how this constraint is to be stated in a descriptively adequate grammar of Spanish. We will then attempt to extract from the constraint what is universal and state it once and for all in linguistic theory, so that linguistic theory will correctly predict the form that surface structure constraints of this type will take in various languages. That which is particular to Spanish in this constraint will have to be stated as such in the grammar of Spanish, but the form of the constraint will be defined by universal grammar in a way that makes correct predictions about Spanish and other natural languages.

The most direct way to state the constraint would be simply to list the ungrammatical sequences of pronouns. We could then state the constraint in something like the following form:

- (61) If the output of the transformational component contains any of the following sequences of pronouns, the sentence is ungrammatical:

me te

nos te

le me

se se

This would be observationally adequate in terms of the data already considered. But this method of ruling out ungrammatical pronoun sequences

makes no predictions whatsoever about the grammaticality of further, as yet not considered, possible sequences of pronouns. It would certainly be preferable to state the constraint in such a way that it will make predictions about additional possible pronoun sequences that will reflect speakers' intuitions about them, and thereby attempt to attain a descriptively adequate statement of this surface structure constraint.

We can begin by examining the ungrammatical pronoun sequences in (61) to see if there are any generalizations that can be made about them. We note first that both me te and nos te are ungrammatical. Since both me and nos are first person pronouns, we can exclude both of these sequences by means of a single statement:

- (62) If the output of the transformational component contains a first person pronoun followed by a second person pronoun, the sentence is ungrammatical.

Continuing to examine the ungrammatical pronoun sequences in (61), we note that le may not precede me. Seeking to generalize this constraint, we find that not only le, but also its plural, les, may not precede me.

There are grammatical sentences like

- (63) *Me les escapé.*

'I escaped from them.'

- (64) *Los sorprendí cuando me les presenté.*

'I surprised them when I introduced myself to them'

but there are no grammatical sentences with the pronoun sequence les me.

These facts extend to the first person plural clitic nos, which may precede le and les but may not follow them. We can now give the constraint that rules out le me in a more general form:

- (65) If the output of the transformational component contains a third person Dative clitic pronoun followed by a first person clitic, the sentence is ungrammatical.

As they are stated above, (62) and (65) are two totally unrelated constraints, which cannot be collapsed or combined into a single constraint. The notation (or lack thereof) in (62) and (65) thus claims that there is no generalization which unites them. We could devise various notations to express these constraints. If some other notation makes it possible to state further generalizations we would have to test these generalizations against the data in Spanish to see whether or not they are correct. If the generalizations they make turn out to be correct, we will adopt a notation which makes it possible to state these generalizations over one which does not.

(62) and (65) state that certain pronoun sequences are ungrammatical. To impose such a constraint, then, is essentially to pass some kind of a template or filter over sentences generated by the transformational component - a template which characterizes the ungrammatical pronoun sequences - and to discard sentences which conform to the template of ungrammaticality. We can make this filtering nature of the output constraint explicit by stating directly the sequences of clitics that are ungrammatical, restating (62) as follows:

(66) Output condition on clitic pronouns: * I II

This has the same meaning as (62); any sentence with a first person clitic pronoun followed by a second person clitic pronoun must be discarded as ungrammatical. Similarly, (65) can be given as:

(67) Output condition on clitic pronouns: * ^{III} Dative I

(66) and (67) are notational variants of (62) and (65), but they make explicit the fact that we are using the condition as a filtering template such that anything that conforms to it is discarded as ungrammatical. What is interesting is that looking at (66) and (67) we see that

they can be combined into a single constraint:

(68) Output condition on clitic pronouns: * $\begin{matrix} \text{III} \\ \text{Dative} \end{matrix}$ I II

Stating the constraint in this form has made it possible to combine the two constraints into a single constraint. This is not necessarily an advantage in itself. The important point is that (68) can be interpreted in a way that makes further predictions that (66) and (67) as separate constraints do not make. That is, we can interpret (68) to mean that if a sentence contains any two clitic pronouns in the order given in (68), the sentence will be ungrammatical. This interpretation predicts that there will be no grammatical Spanish sentences with the pronoun sequence: $\begin{matrix} \text{III} \\ \text{Dative} \end{matrix}$ II.

This prediction is correct; there are no such grammatical sentences. At the same time, this interpretation of (68) predicts that the sequence II $\begin{matrix} \text{III} \\ \text{Dative} \end{matrix}$ will be grammatical, for if (68) is the output constraint there is no way to rule out this sequence as ungrammatical. This sequence is indeed grammatical, as can be seen in the sentences

(69) a. Te le escapaste.

'You escaped from him.'

b. Te les escapaste.

'You escaped from them.'

Since (68), with the interpretation that we have given it, makes additional correct predictions that (66) and (67) as separate constraints failed to make, we will adopt (68) with this interpretation in preference to (66) and (67).²⁰ In so doing we will be adopting a more general output constraint from which (66) and (67) follow as special cases. The notation which made the statement of this generalization possible was one which made explicit that the output constraint has the form of a template to be passed over the output of the transformational component. This constitutes

evidence in favor of this interpretation of output constraints.

Now that the constraint is viewed as a template in this fashion, another question arises: should its statement be positive or negative? That is, instead of (68), which characterizes the ungrammatical pronoun sequences, should we instead state the output condition by stating the pronoun sequences that are grammatical? That is, we could adopt

(70) Output condition on clitic pronouns: II I III
Dative

instead of (68). (70) is to be viewed as a template which characterizes the grammatical pronoun sequences, and any sentence which contains a sequence of clitic pronouns which does not conform to (70) will be discarded as ungrammatical. At issue is the nature of the output constraint. Is it a template which characterizes ungrammatical pronoun sequences or grammatical ones? This again is an empirical issue which must be decided one way or the other on the basis of empirical evidence.

In terms of the data considered so far, (68) and (70) are equivalent; either statement of the constraint will accept and reject the same sequences of clitic pronouns. However, the 'positive' notation of (70) makes it possible to rule out additional pronoun sequences which the 'negative' notation of (68) is unable to rule out. If a given pronoun P is included in only one slot in the 'positive' notation of (70), it will follow that sentences with the sequence P P will be ruled out as ungrammatical, since they will fail to conform to the filtering template. Thus, if we adopt the 'positive' notation of (70) we have only to find the proper place in the chart for the clitic se, and it will follow automatically that sentences with the pronoun sequence se se will be discarded as ungrammatical. We have already seen that se se sequences are ungrammatical, and that they cannot be blocked in a natural way by constraining transformations.

Since the 'positive' notation of (70) gives us this result automatically, while there is no way to achieve it with the 'negative' notation of (68), we adopt the notation of (70) to state the output condition. In so doing, we are maintaining that the output condition is not a statement of ungrammatical pronoun sequences, but a template which characterizes the grammatical ones, and that sentences that fail to conform to it are thereby characterized as ungrammatical.

It remains only to find the place of se in the output condition chart. Since there are sentences with the sequence se te such as

(71) Se te perdió la llave.

'The key got lost on you.'

se must precede II in the chart. The output constraint is therefore:

(72) Output condition on clitic pronouns: se II I III
Dative

(72) automatically characterizes as ungrammatical the sequence se se, as well as any of the following sequences, which consist of two clitics from the same slot of (72):

(73) *te te
*me me
*nos nos
*me nos
*nos me
*le le
*les les
*le les
*les le

In fact, none of the pronoun sequences can occur in a grammatical sentence of Spanish. This is predicted by the notation of (72).

With the notational convention that we have adopted, the output condition (72) makes still further predictions. It predicts that the pronoun sequences se me, se nos, se le, and se les are also grammatical. These predictions are borne out by the data.

- (74). a. Se me perdió la llave.
 'The key got lost on me.'
 b. Se nos perdió la llave.
 'The key got lost on us.'
 c. Se le perdió la llave.
 'The key got lost on him.'
 d. Se les perdió la llave.
 'The key got lost on them.'

At the same time, (72) predicts that no other clitic pronoun may precede se. This prediction is also correct; there are no grammatical sentences in which another clitic pronoun precedes se.

We have now incorporated into the output constraint all clitic pronouns except the third person Accusative pronouns. We have seen that they may follow first person pronouns.

- (75) a. Miguel me lo recomendó.
 'Miguel recommended it to me.'
 b. Miguel nos lo recomendó.
 'Miguel recommended it to us.'

Given our notation, they must therefore follow 'I' in (72). However, they may not precede the third person Dative pronouns. Sequences like lo le, lo les, las le, las les, etc. are ungrammatical. We have seen that the third person Dative pronouns are converted to se before third person Accusative pronouns by the spurious se rule. We might therefore think it

go well beyond the data on which we based our statement of the constraint. In this sense the constraint (77) is descriptively adequate; it makes correct predictions about speakers intuitions about novel sentences. This cannot be accidental. We therefore tentatively propose that the chart notation we have used in (77) be defined in linguistic theory as the means by which surface structure constraints on the order of clitics in natural language are to be stated. If this is correct, it will follow that in any language in which the order of clitics is subject to an output condition, the condition will be statable as a template or filter in chart form, like (77), and that this template or filter characterizes the grammatical sequences of clitics. Sentences with clitics which do not correspond to the filter will be discarded as ungrammatical.

To claim that the notation embodied in (77) is a linguistic universal on output conditions on the order of clitics is to make a very strong claim. It entails that in any language with an output condition on the order of clitics in which sentences with the clitic sequences AB and BC are grammatical, the output constraint must be expressed in the following form:²²

(78) Output Condition: A B C

Given the interpretation that we have shown this notation to have, therefore, the proposal that this notation is universal entails the claim that if sentences containing the clitic sequences AB and BC are grammatical, the following also hold:

- (79) a. BA is ungrammatical.
 b. CB is ungrammatical.
 c. AC is grammatical.
 d. CA is ungrammatical.

e. ABC is grammatical.

f. CBA is ungrammatical.

The claim that this notation is universal also entails that in all languages such constraints are to be stated 'positively' rather than 'negatively,' that is, the chart expresses the grammatical (rather than the ungrammatical) sequences of clitics, and sentences with clitics which do not conform to it are discarded as ungrammatical. If this notation is universal, it also follows that sentences containing more than one clitic from a given column of the output condition chart will be ungrammatical.

Postulating this notation as a universal for output conditions on the order of clitics is an explanatory hypothesis. If this is the only way such constraints can be expressed, it explains why the grammars of natural languages exhibit output constraints of this form. Since these constraints make predictions about particular facts in individual languages, a hypothesis which requires that such constraints be stated in this way sets constraints on what kinds of facts can be found in natural languages. It thus constrains the notion 'human language.' In so doing it explains why it is that we find these facts in natural languages, rather than others.

By postulating a universal notation for the statement of output conditions on the order of clitics we are extracting from the chart (77) what is universal and stating it once and for all in linguistic theory. This is to claim that the form of the output condition (77) is not part of the grammar of Spanish, but rather belongs to universal grammar. What is particular to Spanish in (77) involves the particular elements that are subject to the output constraint, and the order in which they must appear. The fact that it is the object pronouns in Spanish that are subject to the output constraint, the fact they are arranged by person rather than in

some other way, the particular order in which they appear in (77), and the presence of the morpheme se in (77) and its order relative to the other clitics - that is what is particular to Spanish in (77) and must be stated in the grammar of Spanish. The way that this information must be stated in the grammar of Spanish - that it takes the form of the chart (77) - this fact belongs not in the grammar of Spanish, but in universal grammar.

Since it is the form of the constraint (77) that makes predictions about novel sentences in Spanish, and since under our hypothesis the form of this constraint is part of universal grammar, our hypothesis on the universal form of such output constraints is able to explain additional facts about Spanish. We established the constraint (77) on the basis of which pairs of clitics occur in grammatical sentences of Spanish. Our hypothesis now explains why it is that certain sequences of more than two clitics are grammatical. It predicts that any otherwise grammatical sentence that it is possible to construct with more than two clitic pronouns which conform to (77) will be grammatical. It thus explains why sentences like the following are grammatical.

- (80) a. Se me le cayó la piedra al anillo.
'The stone fell from my ring (on me).'
- b. No te me lo comas.
'Don't eat it up (on me).'
- c. Te nos la robaste.
'You stole it for yourself from us.'

Such sentences with more than one Dative of Interest on a single verb might be considered somewhat awkward but they are grammatical. Their grammaticality has now been explained.

There are sentences with more than two clitic pronouns which one would expect to be generated by the transformational component, but which turn out to be ungrammatical. These cases are interesting because the form of the constraint (77), supplied by universal grammar, explains why these sentences are not grammatical in Spanish.

The sentence

(81) Te le comiste el pan a Miguel, pero a mí no te me lo comas.

'You ate up Miguel's bread (on him), but don't you eat up mine (on me).'

is fully grammatical, but if we interchange Miguel and mí in the deep structure of (81), we end up with an ungrammatical sentence.

(82) a. *Te me comiste el pan a mí, pero a Miguel no te le lo comas.

b. *Te me comiste el pan a mí, pero a Miguel no te se lo comas.

'You ate up my bread (on me), but don't you eat up Miguel's (on him).'

(82a) is ungrammatical because of the pronoun sequence le lo; the spurious se rule should apply to such sequences. But if we apply the spurious se rule, we end up with the sequence te se lo. The universal notation for the statement of such output constraints entails that in any language in which the clitic sequence AB is grammatical, the sequence BA is ungrammatical. Since, as we have seen, se te is grammatical in Spanish, as in

(83) Se te perdió la llave.

'The key got lost on you.'

our theory predicts that any sentence which contains the clitic sequence te se will be ungrammatical. It thus explains why *(82b) is ungrammatical - why it is that although (81) is a grammatical sentence of Spanish, if we interchange Miguel and mí in the deep structure of (81), we end up with an ungrammatical sentence.

The universal form for such output constraints receives further empirical support from Spanish through consideration of sentences like

(84) *Luís le cortó el pelo a mi hija, pero a mi hijo no se lo cortó.*

'Luís cut my daughter's hair, but he didn't cut my son's.'

Se lo in the second half of (84) is derived from le lo by the spurious se rule. This sentence can also occur with a first person singular Dative of Interest:

(85) *Luís me le cortó el pelo a mi hija.*

'Luís cut my daughter's hair for me.'

But if we add this Dative of Interest to (84), we end up with an ungrammatical sentence.

(86) a. **Luís me le cortó el pelo a mi hija, pero a mi hijo no me le lo cortó.*

b. **Luís me lo cortó el pelo a mi hija, pero a mi hijo no me se lo cortó.*

'Luís cut my daughter's hair for me, but he didn't cut my son's (for me).'

In *(86a) the spurious se rule has not applied, resulting in an ungrammatical sentence. *(86b) has the pronoun sequence me se lo, which we would a priori have no reason to consider ungrammatical. But the notation of (77), supplied by universal grammar, together with the actual contents of (77) in Spanish, which were motivated by entirely independent considerations, predicts that any sentence with me se lo in surface structure will be ungrammatical. Our theory thus explains why it is that adding a first person singular Dative of Interest to (84) results in an ungrammatical sentence. The correctness of these predictions lends further empirical support to the notation we propose to include in universal grammar.

If the notation of (77) is indeed part of universal grammar, we must expect it to make correct predictions about grammaticality in all

languages in which the order of clitics is subject to a surface structure constraint. It will then explain these facts in various languages, at the same time that these languages will add to the empirical support for the proposed universal notation. If, on the other hand, this notation makes incorrect predictions in other languages, we must discard it in its present form and replace it with some other principle that will account for the additional facts we find in other languages, while at the same time making correct predictions for the Spanish data we have already examined.

While we cannot say with certainty that every human language will confirm the correctness of the notation of (77), there are certainly other languages that lend it further empirical support. In literary French, for example, part of the output constraint on clitic pronouns must read as follows:²³

(87) Output constraint on clitic pronouns:

I, II	III	III
	Acc	Dative

The notation used here must have exactly the same interpretation as that of (77). As a result, if we use a verb like se rappeler ('remember'), which occurs with an obligatory reflexive pronoun, we can say

(88) Je me rappelle Jean.

'I remember Jean.'

If Jean is pronominalized, we get

(89) Je me le rappelle.

'I remember him.'

me is the obligatory reflexive pronoun with se rappeler, and le is the object pronoun. (89) conforms to (87) and is therefore grammatical. But corresponding to (89) there is no way to say "I remember you," using a clitic pronoun for the direct object.

(90) *Je me te rappelle.

(91) *Je me vous rappelle.

These sentences are ungrammatical because the first and second person pronouns are in the same column of (87). As a result, it is impossible to have both with the same verb in a grammatical sentence. In order to say 'I remember you' in literary French, it is necessary to have recourse either to the disjunctive (non-clitic or 'strong form') pronouns, as in

(92) Je me rappelle toi.

'I remember you.'

(93) Je me rappelle vous.

'I remember you.'

or else to a different verb which takes its object in a prepositional phrase.

(94) Je me souviens de toi.

'I remember you.'

The ungrammaticality of *(90) and *(91) in literary French is strong additional evidence for the notation used in (77) and (87).

We stated earlier that in any language with an output constraint on the order of clitics, if the clitic sequences AB and BC are grammatical, the output constraint must be expressed as:

(78) Output condition: A B C

But this statement is actually too strong in that it goes beyond what we have actually shown to be the case. We have given evidence in support of the notation of (77), but nothing prevents a given element or class of elements from appearing in two different columns of an output condition chart. In the hypothetical case above, for example, if AB and BC are grammatical, it does not necessarily follow that the output constraint

must be expressed as (78). The following one is also possible:

(96) Output condition: A A B C

In (96) A appears twice. As a result, given the notation we have adopted and the interpretation that we have shown it must have, the following sequences of clitics will also be grammatical:

(97) AA

AAB

AAC

AABC

The other predictions enumerated in (79) will still hold. The grammaticality of the sequences in (97) in addition to the predictions enumerated in (79) and the ensuing paragraph follow from the notation we have motivated here.

It holds equally of (96). The only difference between (96) and (78) is that in (96) A appears in two different columns. The notation and its interpretation are the same.

It is an empirical question whether output condition charts like (96), in which some element appears in more than one column, are actually to be found in natural languages. The answer to this question appears to be affirmative. It is reported by Heger (1966) that alongside the system of 'normative' literary French, for which the permissible sequences of clitic pronouns other than se, y, or en, are defined by (87), there is another system, which I will refer to as 'colloquial French.' In colloquial French, according to Heger, sentences like the following are grammatical:

(98) Je me te rappelle.

'I remember you.'

(99) Tu te me rappelles.

'You remember me.'

The existence of such a dialect provides us with a crucial test of the

notation we have proposed. This is so because our notation predicts that it is impossible for a language to be like literary French, with the sole exception that (98) and (99) are also grammatical. If our notation is correct, the grammaticality of (98) and (99) automatically entails that other sentences that are ungrammatical in literary French will be grammatical in colloquial French. For if (98) and (99) are grammatical, under the assumption that colloquial French is like literary French in other respects, then the relevant part of the output condition chart for colloquial French is not (87) but rather:

(100) Output constraint on object pronouns:

I, II	I,II	III	III
		Acc	Dative

(100) is like (87) except that the first column appears twice. This means that sentences with sequences of two pronouns drawn from the set I, II should be grammatical in this dialect. And in fact they are. In literary French, for example, in order to say 'I will show myself to you' it is necessary to use the strong form of the pronoun vous.

(101) Je me montrerai à vous.

'I will show myself to you.'

Using the clitic pronoun vous in literary French results in an ungrammatical sentence

(102) *Je vous me montrerai.

because both vous and me are in the first column of (87). But Heger reports that in colloquial French (102) is perfectly grammatical. This follows directly from (100) and the interpretation that we have shown this notation must have.

Postulating (100) as the output condition chart for colloquial French and the interpretation we have given to the notation leads to

another prediction. In colloquial French, sentences with sequences of two instances of the same first or second person clitic pronoun should be grammatical. And indeed they are. Heger cites the example

(103) *Ma mémoire ne me me montre pas mettant la lettre à la poste.*

'My memory doesn't show me to myself mailing the letter.'

(103), which is ungrammatical in literary French, is grammatical in colloquial French. This is an extremely important fact, for it confirms the notation we have used to state output constraints on clitic pronouns in a particularly striking way. If sentences like (98) and (99) are grammatical in this dialect, the output condition chart must be (100) rather than (87). The notation that we have adopted entails that (103) must be grammatical as well. The grammaticality of (103) in this dialect is striking confirmation of the notational convention we have employed.

The grammaticality of (103) in colloquial French also shows that it is not impossible for a language to allow sequences of the same clitic in grammatical sentences. The ungrammaticality of the se se sequence in Spanish, for example, can not be explained by means of some general constraint that repetitions are somehow automatically ungrammatical or 'non-euphonious.' It is a direct result of the inclusion of se in only one column of the output condition chart of Spanish. The proposed universal interpretation of this notation then predicts that se se sequences in Spanish will be ungrammatical.

Any attempt to explain the ungrammaticality of certain sequences of clitics on the basis of some such notion as 'euphony' will fail in several respects. As examples like (103) in colloquial French show, the ungrammaticality of this sequence in literary French is due not to any properties of 'euphony' but rather to the fact that literary French has the

output condition chart (87) rather than (100). More important, even in literary French, where the notation of (87) automatically excludes sequences of two or more instances of the same clitic pronoun, ungrammatical sequences of pronouns cannot be characterized in terms of phonological shape, which is what a theory of 'euphony' would require. This is because the output constraint applies to sequences of object pronouns. Subject pronouns do not come under its purview. Since some of the subject pronouns and object pronouns of French have the same phonological shape, we can show that sequences of the same sounds which are ungrammatical as object pronouns are perfectly grammatical as sequences of subject pronoun plus object pronoun. Thus, while (103) and sentences with the sequences of object pronouns me me, te te, nous nous, and vous vous are ungrammatical in literary French, the following sentences are perfectly grammatical:

(104) Nous nous rappelons qu'elle avait les yeux bleus.

'We remember that she had blue eyes.'

(105) Est-ce- que vous vous rappelez son sourire à moitié caché?

'Do you remember her half-hidden smile?'

These sentences are grammatical in literary French because the first pronoun in each case is a subject pronoun and does therefore not come under the purview of the output constraint on object pronouns. The 'sequence of object pronouns' consists of only the second nous in (104) and the second vous in (105). The output condition chart (87) allows these, and as a result (104) and (105) are grammatical. Since (104) and (105) contain the sequences nous nous and vous vous, the ungrammaticality of nous nous and vous vous sequences of object pronouns in literary French can not be explained by means of any notion of 'euphony'. The notation of (87) accounts for not only ungrammatical nous nous and vous vous sequences of object

pronouns in literary French, but for a variety of other facts as well.

The fact that the notation we have adopted in (77), (87), and (100) makes correct predictions of the kind we have noted makes it look extremely likely that it is part of universal grammar. In each case we have examined, particular data in particular languages is generalized in exactly the way this notation requires.

We will now tentatively propose that the following two principles be included in universal grammar.

(106) If there are constraints on the order of clitics, these constraints are surface structure constraints in all natural languages.

(107) Such surface structure constraints are expressed in the notation of (77), with the interpretation we have shown it to have, in all natural languages.

(106) presupposes that a definition of 'clitic' is also supplied by universal grammar.²⁵

(107) may turn out to be inadequate as it stands if a wider range of phenomena than just constraints on the order of clitics turn out to be surface structure constraints expressed in the notation of (77). If we consider the constituents of the English noun phrase, for example

(108) all the pretty little red brick houses

and if we take (108) to be a chart with the notation of (77), then if we make the noun houses obligatory, we find that all the combinations of elements predicted by our notation are grammatical, and all others are ungrammatical. Thus there are grammatical noun phrases like

- (109) a. all the red brick houses
 b. all pretty old houses
 c. the little brick houses
 d. all old houses

and many others. But if we put any of the elements in (108) in a different order, the result is ungrammatical.

- (110) a. *red the houses
 b. *red pretty houses
 c. *little all houses
 d. *all the pretty little red old houses²⁶

If the notation of (77) is indeed necessary to state the constraints on the order of constituents in the English noun phrase, then this would constitute evidence that this phenomenon is also a surface structure constraint. It would then be necessary to replace (108) by a chart in which each column indicates the full range of constituents which occupy that position in the noun phrase. It would not be surprising, for example, to find that adjectives are placed in one column or another of the chart on the basis of certain semantic properties. All adjectives indicating color, for example, would occupy the same position with respect to other constituents of the noun phrase that red occupies in (108). And it would remain to discover the full range of linguistic phenomena for which this notation expresses the correct generalizations.

It is also possible that (106) and (107) may turn out to be correct but inadequate as formulated here if the generalizations embodied in them should turn out to be predictable on the basis of other phenomena that we have not considered here. Of course, either (106) or (107) or both can be shown to be false by producing data from any natural language for which they do not hold.

If (106) and (107) are correct, however, they illustrate the subtle interplay between language-particular facts and linguistic universals of which the grammars of natural languages are made. At first glance one

might suppose that nothing could be more language-particular than the constraints on the relative order of clitic pronouns in Spanish, all the more so because the constraint must refer to such language-particular entities as the morpheme se. Yet we have seen how the attempt to state the constraint on the relative order of such language-particular morphemes in Spanish led us to construct a notation for the statement of this constraint that is a likely candidate for inclusion among the universals made available by linguistic theory for use in the grammars of particular languages. The proposed universal notation then succeeded in making correct predictions about additional data in Spanish and two different dialects of French, thereby explaining these facts on the one hand, while these facts lent further empirical support to the universal notation on the other. By proceeding in this way, extracting what is universal from the grammars of particular languages and formulating the universals from which language-particular facts follow, we will find ourselves constructing richer, more substantive theories of language.

4.4 Evidence that the constraint is statable only as a surface structure constraint

In paragraph 4.2 we provided empirical motivation for a constraint to discard as ungrammatical sentences with certain sequences of object pronouns in surface structure. In paragraph 4.3 we discussed the form that the statement of this constraint should take. However, we have not yet shown that the constraints on the relative order of clitic pronouns in Spanish can not be stated in some other way. In paragraph 4.4 we will show first that these constraints can not be stated transformationally, and second, that they can not be stated by means of the phrase structure rules of the base component.

4.4.1 Evidence that the constraint can not be stated transformationally

There are two ways conceivable of stating the constraint on the order of clitic pronouns transformationally. The first would be to regard the chart (77) as the structural change of a clitic-reordering transformation. Under this proposal, there would be a rule which takes all the clitic pronouns in the sentence and rearranges them into the order dictated by (77). Another conceivable way of getting the clitics into the correct order by means of transformations would be to postulate a series of transformations whose effect would be to arrange the clitics in the order specified by (77). We will deal with the former alternative first.

If (77) is not a surface structure constraint, but rather the structural change of a clitic-reordering transformation, then clitic-reordering, being a rule in the grammar of Spanish, must be ordered with respect to other rules. In particular, it must be ordered with respect to the spurious se rule. But ordering clitic-reordering either before or after the spurious se rule results in an inadequate grammar.

If (77) as the structural change of a clitic-reordering transformation precedes the spurious se rule, we must change it slightly and restate it as:

(111) S.C. of clitic-reordering transformation:

<u>se</u>	II	I	III	III
			Dative	Acc

This change is necessary because le and les must be allowed to precede the third person Accusative pronouns in order to derive sentences like

(112) Se lo di a Miguel.

'I gave it to Miguel.

where the se comes from le by means of the spurious se rule. Following

the application of the clitic-reordering transformation (77), the spurious se rule will apply and yield sentences like (112). However, we now have no way to discard as ungrammatical sentences like *(38b) and *(49b), which must be ruled out because they contain se se sequences which came into being as a result of the application of the spurious se rule. We must conclude that if (77) is the structural change of a clitic-reordering transformation (restated as (111)), it can not precede the spurious se rule.

If (77) is the structural change of a clitic-reordering rule which follows the spurious se rule we fare no better. Such a clitic-reordering rule would take an ungrammatical sentence like *(82b) and put the clitics in the 'correct' order embodied in (77). A grammatical sentence should result, but the resulting sentence is ungrammatical:

(113) *Te me comiste el pan a mí, pero a Miguel no se te lo comas.

By the same token, if (77) is the structural change of a clitic-reordering transformation, it should operate on *(86b) to produce a grammatical sentence. But the result

(114) *Luís me le cortó el pelo a mi hija, pero a mi hijo
no se me lo cortó.

is ungrammatical. We must conclude that if (77) is the structural change of a clitic-reordering transformation, it can not follow the spurious se rule.

For exactly the same reasons, (77) can not be the structural change of a clitic-reordering transformation of the type that Lakoff and Ross have called 'anywhere rules,' which can apply at any point in derivations at which their structural description is met. For if this were the case, *(113) and *(114) would be grammatical, and they are not.

If (77) is the structural change of a clitic-reordering transformation, the transformation in question can neither precede nor follow the

spurious se rule, not can it be an 'anywhere rule.' We must conclude that it is not a rule at all.

If we try to state the constraint on the order of clitic pronouns by means of a series of transformations of some kind whose effect would be to rearrange the clitics into the order specified by (77), we run into exactly the same difficulties. If these transformations precede the spurious se rule, we can not rule out the se se sequences produced by the spurious se rule, nor can we characterize as ungrammatical sentences like *(82b) and *(86b), which have the pronoun sequences te se lo and me se lo produced by the spurious se rule. If, on the other hand, the reordering transformations we try to formulate follow the spurious se rule, we can not account for the ungrammaticality of sentences like *(113) and *(114). If we try to order some clitic-reordering transformations before the spurious se rule and others after it, we will still encounter the same difficulties. Sentences like *(82b) and *(86b) will be ungrammatical no matter what order the clitic pronouns come in, as the rearrangement to *(113) and *(114) shows. Similarly, sentences with the clitic sequence se se have to be characterized as ungrammatical, and no amount of rearrangement of the clitics can make them into grammatical sentences.

That no transformation or series of transformations can account for the data in Spanish can be seen quite strikingly with those constructions which, as we have noted, have their own constraints on the order of clitic pronouns which are independent of those embodied in the output constraint (77). In order for a grammatical sentence to result, both constraints must be satisfied. For example, in the construction (115) the reflexive pronoun must precede the non-reflexive. When the reflexive pronoun precedes the other pronoun in the chart (77) as well, we get a grammatical sentence.

- (115) a. Se nos escapó.
'He escaped from us.'
- b. Te me escapaste.
'You escaped from me.'
- c. Me les escapé.
'I escaped from them.'

When (77) is violated, an ungrammatical sentence results.

- (116) a. *Me te escapé.
'I escaped from you.'
- b. *Nos te escapamos.
'We escaped from you.'

Now, if (77) were the structural change of a clitic-reordering transformation, or if there were a series of transformations which had this effect, we would expect such transformational devices to reverse the order of the pronouns in *(116) and thereby yield grammatical sentences. But the resulting sentences are ungrammatical.

- (117) a. *Te me escapé.
b. *Te nos escapamos.

We conclude that (77) is not the structural change of a transformation, or series of transformations, but rather a surface structure constraint which rejects sentences with certain sequences of pronouns as ungrammatical.

The attempt to state the constraint on the order of clitic pronouns in Spanish transformationally is based on the assumption that all that needs to be done to get a grammatical sentence is to arrange the clitics into the correct order. But this assumption is false. *(82b) and *(86b) show this, since their arrangement into the correct order produces the ungrammatical sentences *(113) and *(114). Sentences with the se se

sequence - whether it arises through the application of the spurious se rule, as in *(38b) and *(49b), or by other means, as in *(55b) and *(60b) - also show this, since these sentences are ungrammatical and there is simply no way to make them grammatical. Finally, the sentences in *(116) and *(117) also illustrate the point that rearrangement of the clitic pronouns by some transformational device or other is simply unable to account for all of the data. The data can be accounted for by a surface structure constraint, however, since the function of such a constraint is to filter out ungrammatical sentences. If our surface structure constraint is applied after the application of the spurious se rule, all of the ill-formed sentences discussed here will correctly be filtered out as ungrammatical.

In the course of this discussion we have discovered that there are well-formed deep structures to which there correspond no grammatical surface structures. *(55b) and *(60b), as well as the sentences in *(116), illustrate this nicely, since there are no grounds whatever for ruling out their deep structures as ill-formed, and yet there is no way to actualize these deep structures as grammatical sentences. In the case of the sentences in *(116) we can show this in a particularly striking way. Since 'You escaped from me' and 'You escaped from us' are well-formed deep structures, there are no grounds for characterizing deep structures like 'I escaped from you' and 'We escaped from you' as ill-formed in Spanish. In fact, we can show that these deep structures are well-formed, for they underlie certain grammatical sentences. Spanish has grammatical sentences like

(118) Te le escapaste a Jorge, pero a mí no te me escapaste.

'You escaped from Jorge, but you didn't escape from me.'

from which most of the second half of the sentence can be deleted, pro-

ducing sentences like

(119) Te le escapaste a Jorge, pero a mí no.

'You escaped from Jorge, but not from me.'

Corresponding to (119), the sentence

(120) Me le escapé a Jorge, pero a ti no.

'I escaped from Jorge, but not from you.'

is fully grammatical. The deep structure underlying (120) must be 'I escaped from Jorge, but I didn't escape from you' appropriately expressed in Spanish. In other words, the deep structure 'I escaped from you' in Spanish must be well-formed, for it underlies part of the grammatical sentence (120). But this deep structure by itself can never be actualized as a grammatical sentence of Spanish, because the output runs afoul of the surface structure constraint (77). In just those cases where the part of the sentence containing the clitic pronouns has been deleted does this deep structure emerge as a grammatical sentence. This is the case in (120). This shows that the deep structure of *(116a) is well-formed, and it is only the order of the clitic pronouns in surface structure that causes it to be ungrammatical. The same is true of *(116b), since the sentence

(121) Nos le escapamos a Jorge, pero a ti no.

'We escaped from Jorge, but not from you.'

is fully grammatical. Like (120), (121) can not be continued in the way that (119) can be continued as (118), for if the clitics have not been deleted there is no way to say 'We escaped from you' grammatically.²⁷ But the deep structure of this sentence underlies the second half of (121), and therefore must be well-formed. The existence of sentences like 'I escaped from you' and 'We escaped from you,' which have well-formed deep structures but can not be actualized as grammatical sentences, is therefore

the strongest kind of evidence for a surface structure constraint on the order of clitic pronouns in Spanish. These sentences show that the only kind of grammatical device that can account for the order of clitic pronouns in Spanish is not one that arranges the clitics in a certain order, but rather one that filters out sentences with certain pronoun sequences as ungrammatical.

In paragraph 4.4.1, then, we have shown that in an adequate grammar of Spanish, the constraints on the order of clitic pronouns can not be stated by means of a clitic re-ordering transformation or a series of such transformations. There are sentences with well-formed deep structures which have no corresponding well-formed surface structures. What is needed is a device to filter out certain sentences as ungrammatical. The surface structure constraint (77) performs this function.

4.4.2 Evidence that the constraint can not be stated by phrase structure rules in the base

Since the surface structure constraint (77) is of a form which is generable by a phrase structure rule, it might occur to someone to try to account for the order of clitics in Spanish by generating them in the order of (77) by means of a phrase structure rule in the base component, thereby dispensing with the need to postulate (77) as a surface structure constraint. Any such attempt would immediately encounter insuperable difficulties. We will limit ourselves here to pointing out only two of them; the reader can easily think of others himself.

First, the clitics that occur with a given verb in surface structure are not necessarily generated in the same sentence with that verb in deep structure. This is so because clitics from lower sentences can move

up to higher sentences. For example, the sentence which means 'He wants to promise me to do it' has three grammatical actualizations in surface structure:

- (122) a. Quiere prometerme hacerlo.
 b. Quiere prometérmelo hacer.
 c. Me lo quiere prometer hacer.

'He wants to promise me to do it.'

In (122a), the clitics me and lo are in the sentences in which they originate in deep structure; me ('me') is the object of prometer ('promise') and lo ('it') is the object of hacer ('do'). In (122b), the clitic lo has moved up from S_3 to S_2 , while in (122c), both me and lo have moved up to S_1 . Strict subcategorizational and selectional facts about particular verbs must be stated in deep structure. In the course of a derivation, the objects of verbs may move up to higher sentences. As a result, the clitics that appear in a given sentence in surface structure may have originated either in that sentence or in any of various embedded sentences in deep structure. Generating the clitics in the sentence in which they appear in surface structure by means of a phrase structure rule would make it impossible to state strict subcategorizational and selectional facts about particular verbs. It would also make it impossible to account for the distribution of the clitic pronouns, since they may occur in surface structure in the sentence in which they originate in deep structure, or they may move up to higher sentences in the tree. But they can not occur in both places at one. For example, we must generate the three sentences in (122) while ruling out as ungrammatical such non-sentences as

- (123) a. *Quiere prometérmelo hacerlo.
 b. *Me lo quiere prometérmelo hacer.

This sentence is ungrammatical, and we need a surface structure constraint to rule it out. In similar fashion, since we must generate

(130) No te me lo comas.

'Don't eat it up on me.'

we will also find ourselves generating

(131) *No te le lo comas.

'Don't eat it up on him.'

which the spurious se rule will convert into

(132) *No te se lo comas.

which must be ruled out by an output constraint. Similarly, since we have grammatical sentences like

(133) No me le cortes el pelo a mi chiquita.

'Don't cut my little girl's hair for/on me.'

If we use the pronoun lo instead of el pelo we get an ungrammatical sentence;

(134) *No me le lo cortes.

which the spurious se rule will convert into

(135) *No me se lo cortes.

which must be ruled out by an output condition. If we attempt to generate the clitics in their surface structure order in deep structure, we end up having to postulate (77) as an output constraint anyway, in order to rule out sentences like *(128), *(132), and *(135). There is then no need to try to generate them in their surface structure order in deep structure. The attempt to do this was based on the same false assumption that motivated the attempt to state the constraints on the order of clitics transformationally - the assumption that all that is needed is to get the clitics into the correct order. We have seen that this assumption is false

because it overlooks the essential aspect of the constraint; it acts as a filter which rejects certain sentences as ungrammatical. This filtering function remains the strongest motivation for the surface structure constraint we have postulated.

4.5 Theoretical points.

We have taken pains to show that the surface structure constraint (77) is part of the grammar of Spanish, and that the effect of this constraint can not be obtained by means of transformations. As a result, we have not discussed the means by which the clitics get into the correct order so that the sentence in question can successfully negotiate the output constraint. Ignoring the problem of clitics moving up from lower sentences by restricting ourselves to simple sentences without embedding, it seems that we can give the following rule:²⁸

(136) Clitics move to the verb in their S.

It must somehow be stated that the clitics come before a finite verb, after an infinitive or present participle, and that with past participles they must move up to the 'auxiliary verb.' The question of how these conditions are to be stated does not concern us here. The important point is that the rule need not specify anything whatever about the relative order of the clitic pronouns. The clitics can tumble onto the verb helter-skelter, in any order whatsoever. Those sentences in which they happen to land in an order which conforms to (77) will qualify as grammatical. The constraint (77) will reject all other sentences as ungrammatical. If the rule that moves clitics to the verb precedes the spurious se rule, sentences like *(38b) and *(49b), *(82b), and *(86b) will be rejected by (77), and all of the data discussed here will be accounted for.

We usually expect the statement of transformations to specify the kind of adjunction they use; this is necessary in order to make explicit the derived constituent structure that they produce. The transformation (136) does not specify any kind of adjunction or derived constituent structure, so the question naturally arises of what kind of derived constituent structure we have when clitic pronouns have been moved to the verb. Is there some kind of node that indicates we have a sequence of clitic pronouns in derived structure? The answer to this question seems to be negative. First, there is no way a transformation like (136) could produce such a node. Second, there is simply no reason to have such a node in derived structure; the group of clitics does not behave as a single constituent with respect to any rules in the grammar. Furthermore, to have a surface structure node dominating the clitic pronouns would yield highly unintuitive surface structures. Consider, for example, the sentence

(137) *Se me lo permitió.*

'I was allowed (to do) it.'

Here we have the impersonal se, the indirect object pronoun me, and the direct object pronoun lo, which could be replacing a deleted sentence. A node dominating the sequence se me lo in surface structure would be highly unintuitive, and it is not at all clear what such a node should be labelled. The clue to the appropriate generalization here is the fact that the only stress in this sentence is on permitió, so that the entire sentence is a single phonological word. The relevant generalization concerning the status of the clitics in surface structure has nothing to do with derived constituent structure, but rather involves the fact that they form a single phonological word with the verb that they latch on to.

Viewed in this light, the positioning of clitic pronouns in a fixed order adjacent to the verb in Spanish seems quite similar to the situation in highly inflected and agglutinative languages, in which strings of morphemes which must come in a certain fixed order are attached to the verb. Parallels of this sort call into question the traditional division between morphology and syntax and suggest that some of the same grammatical devices may be necessary to account for both syntactic and morphological phenomena.

We must also address ourselves to the question of the level of derivations at which the surface structure constraint (77) applies. We have seen that it must apply after the spurious se rule, which is a very late low-level rule. Furthermore, there do not seem to be any syntactic rules in Spanish which must apply after the constraint (77). For these reasons it seems that (77) applies to the final output of the syntactic component. This accords well with two facts about the constraint. First is the fact that the relevant generalization about the role of the clitics in surface structure is that they form a single phonological word with the verb. Second, in the application of (77) morphemes must already be spelled out in their phonological shape for, as we have seen, the morpheme se behaves the same with respect to (77), regardless of whether it is reflexive se, impersonal se, or spurious se. The amount of phonological information to which (77) is sensitive is extremely restricted; it seems to be confined to the phonological shape of morphemes, and certainly does not extend to phonological features of segments. It is an interesting question how just the kind of phonological information to which surface structure constraints are sensitive can be characterized and, more important, predicted by linguistic theory, but we will not go into these problems here. The fact that the constraint (77) seems to be somewhere

on the border line between syntax, morphology, and phonology accords with its applying to the final output of the transformational component.

The device that we have proposed to account for the constraints on the order of object pronouns in Spanish is reminiscent of the 'morpheme order charts' to be found in the linguistic literature. These charts usually list morphemes in columnar charts similar to (77) and they are usually accompanied by a statement to the effect that only one item from each column may be chosen, and that they must come in the order in which the columns are represented in the chart. In this respect morpheme order charts resemble our constraint (77), and the reader may be wondering whether we are not advocating a return to morpheme order charts in linguistic theory.

In paragraph 4.3 we took pains to justify the notation used in the constraint (77), thereby motivating the claim that this notation expresses linguistically significant generalizations. To the extent that morpheme order charts employ the same notation, it follows that they, too, express significant generalizations. But a viable notation does not by itself make a grammatical device able to account for linguistic phenomena. What makes the constraint (77) different from the morpheme order charts that have appeared in the literature is the fact that it is integrated into a linguistic theory which postulates transformational rules which convert deep structures into surface structures. Within this framework, we showed that (77) can not be stated other than as a surface structure constraint, and that it performs a filtering function that other grammatical devices can not perform. The morpheme order charts that have appeared in the literature have not been shown to have this filtering function, and as such they are inadequate. The usual interpretation of

such charts is that the morphemes in question must appear in the order indicated in the chart; one would take this as an instruction to arrange the morphemes in this order. But it simply is not true that if one takes the clitics in any sentence and arranges them in the order of (77) the result will be a grammatical sentence. This is what has been shown in paragraph 4.4. If rearranging the clitics into the order of (77) were all that is needed, then sentences like *(113), *(114), and *(117) would be grammatical, and they are not. The chart (77) becomes an adequate grammatical device only if it is used to perform a filtering function, filtering out sentences with sequences of clitics that do not conform to it. And the notion 'filtering function' simply has no meaning outside of a generative theory, since without such a theory there is nothing to filter. Although the notation employed by morpheme order charts captures significant generalizations, as we have attempted to show, morpheme order charts can not, by themselves, account for grammaticality and ungrammaticality in Spanish, but must be integrated into a theory with transformational rules, being used to filter out certain sentences generated by the transformational component. It seems reasonable to expect that if morpheme order charts have any validity at all, it is in the role of surface structure filters that we have shown (77) to have. This generalization is in fact captured by a linguistic theory which postulates surface structure constraints which use the notation of (77), as has been proposed here.

The output constraint chart (77) also bears a certain superficial resemblance to the kinds of devices posited in tagmemic theory. To the extent that tagmemics, like morpheme order charts, represents a technique for field work and organizing data, it makes no claims to truth and no

facts can confirm or refute it. But to the extent that tagmemics is a substantive theory of language, it claims that sentences of human languages can be represented in terms of "tagmemes," which Elson and Pickett (1965) define as follows:

The tagmeme, as a grammatical unit, is the correlation of a grammatical function or slot with a class of mutually substitutable items occurring in that slot. This slot-class correlation has a distribution within the grammatical hierarchy of a language.

The term slot refers to the grammatical function of the tagmeme. The terms 'subject', 'object,' 'predicate,' 'modifier,' and the like indicate such grammatical functions.

A common misunderstanding of the term tagmeme is that the term slot is taken to refer exclusively or primarily to the linear position in which morphemes and morpheme sequences are found. This is not the case. Slot refers primarily to ²⁹ grammatical function and only secondarily to linear position.

Although the 'tagmemic formulas' used in the literature on tagmemics produce models of sentences which bear some resemblance to the chart (77) for Spanish clitic pronouns, we see that the basic claim of tagmemics is that these slots represent grammatical function. It turns out, then, that our findings on object pronouns in Spanish refute the basic claim of tagmemics. For the 'slots' into which the mutually substitutable classes of Spanish clitic pronouns must go do not represent function at all. In fact, we saw that the object pronouns must be arranged according to person as in (77), regardless of their grammatical function, and that se, which can have the most diverse sources, goes into the same slot regardless of its grammatical function. We have discovered, then, an aspect of surface structure in which morphemes must be arranged in a particular order that has nothing to do with grammatical function. Since tagmemics claims that the surface structure of sentences can be classified into tagmemes as defined above on the basis of function, the claim

is shown to be false.³⁰

The consequences of this research on clitic pronouns in Spanish for transformational-generative grammar are two in number. First, we have attempted to show that the notation of (77), the notation used in 'morpheme order charts,' captures significant generalizations and therefore has a place in linguistic theory. Second, we have attempted to show that constraints expressed in this notation perform a filtering function by discarding as ungrammatical any sentences generated by the transformational component which do not conform to them. Such filtering devices are an extension to another kind of grammatical device of the notion of filtering in grammar proposed by Chomsky.

Footnotes to Chapter Four

1. The relevant quotations are on page 237 of Gili y Gaya and page 199 of the Academy grammar.
2. Stockwell, Bowen, and Martin (1965), p. 194.
3. Chomsky (1965), pp. 138-139.
4. The addition of output conditions to linguistic theory was first proposed within the framework of generative grammar by Ross (1967), Chapter Three.
5. In some sentences, as in this one, the strong form of the pronoun (ella) is repeated in the weak or clitic form (la). The preposition a appears before non-clitic Animate direct objects.
6. The English translations of Spanish sentences are intended to convey the general meaning; attention has not been paid to nuances and shades of meaning.
7. I am translating third person pronouns as masculine singular when the Spanish sentence contains no further specification. (8c) might also be translated as 'I recommended it to her' or 'I recommended it to them.' The Spanish sentence could be rendered unambiguous in this respect by adding the strong form of the pronoun, forming sentences like Se lo recomendé a ella and Se lo recomendé a ellos. None of this, however, affects the points being made here.
8. There are evidently some dialects (e.g. in Ecuador) in which Dislocation does not entail this reduplicated pronoun. This argument and others based on this feature of standard Spanish would therefore not hold for such dialects.

9. In these sentences we have the verb comer ('eat') together with a Dative of Interest that is identical to the subject and consequently undergoes reflexivization, resulting in reflexive se. A somewhat more literal translation might be 'Luís ate the bread for himself' or 'Luís ate the bread with respect to himself.' I have chosen to translate instances of comer with a reflexive Dative of Interest as 'eat up,' as opposed to comer without this Dative of Interest, which I translate simply as 'eat.'
10. Spurious se likewise never arises from a Nominative third person pronoun.
11. Some informants did not accept (24b) and (26b). For such speakers the argument presented here is not valid in its present form. The point of this argument, however, is that there are grammatical sentences with the pronoun sequence te me and te nos, but none with me te or nos te. This, the crucial fact, also holds for the speakers who did not accept (24b) and (26b). They accepted sentences like Quieren arrebatárteme ('They want to steal you away from me.') and Quieren arrebatártenos ('They want to steal you away from us.'), which are quite analogous to (24b) and (26b). But these informants rejected as ungrammatical *Quieren arrebatármate and *Quieren arrebatárnoste, for there are no grammatical sentences with the pronoun sequences *me te and *nos te. One is therefore led to suspect that their non-acceptance of (24b) and (26b) may be due to some idiosyncratic properties of certain verbs like recomendar, but I have no explanation for this puzzling fact.

12. Any attempt to make (28) or a modification of it actually work would encounter serious difficulties, for when the object pronouns have been preposed to before the finite verb there are grammatical sentences in which the indirect object is second person singular and the direct object is first person.

(i) *Me ocupaste porque to me habían recomendado.*

'You hired me because they had recommended me to you.'

The facts are the same in sentences like

(ii) *Te me presenté.*

'I introduced myself to you.'

The grammaticality of (i) is subject to the caveat discussed in footnote 11. Actually, the sentence *Te me habían recomendado* seems to be ambiguous, the interpretation varying with the context with which it is supplied. It seems to be able to mean either "They recommended me to you" or "They recommended you to me." Since these facts are rather slippery, and since we aim to reject (28) in favor of a surface structure constraint on the order of object pronouns in Spanish, we will leave these facts here without further comment.

13. I am indebted to Guillermo Segreda for these examples.
-
14. This is actually the weakest point in the argument being presented here. I have shown sentences with *recomendar* in which the indirect object clitic pronoun precedes the direct object clitic, but I have not shown that we would really expect a sentence like *(34b) to be grammatical. There are additional puzzling facts in connection with sentences like these. One concerns the fact that the pronoun

sequence me le with recomendar is ungrammatical.

(iii) *Me le recomendó.

'He recommended me to him.'

(iv) *Ramón quería recomendámele.

'Ramón wanted to recommend me to him.'

I have no idea why these sentences are ungrammatical. This is one example of the fact that the output constraint that I propose in this chapter is unable to account for all ungrammatical sentences involving the clitic pronouns in Spanish. Of course, it is not at all clear that the ungrammaticality of *(iii) and *(iv) is due to the arrangement of the clitic pronouns in surface structure. Determination of the source of the ungrammaticality of these sentences must be left to future research. Still, the major point that I am making here is true: the clitic sequence me le occurs in grammatical Spanish sentences (although not everywhere we might expect it), but there are no grammatical sentences with the pronoun sequence le me.

15. In fact, the doubling of indirect objects of this type as clitic pronouns is obligatory regardless of whether or not they have been dislocated. This fact is relevant, since it means that it will not be possible to produce a grammatical sentence from the structure underlying *(38) by attempting to block the preposing of the indirect object.
16. It should be clear that I am not using the term 'Pro' to refer to any pronoun. Rather, by 'Pro' I mean the entity that is realized as on in French and as man in German. Since this entity has no

phonological shape in English, 'Pro' seems as good a name as any.

17. The question should be raised of whether linguistic theory should allow any transformation to cause derivations to block. A low-level rule like the spurious se rule hardly seem like the kind of rule that should cause an entire derivation to block. Another point should also be raised in this connection. The 'filtering function of transformations' seems best motivated in those cases where a metaconstraint of some kind can account for the 'blocking' of a particular transformation. The examples discussed in Chomsky (1965), where it is proposed to give transformations this filtering function, concerned phrase markers with relative clause structure where there is no noun phrase in the relative clause that is identical to the antecedent in the matrix sentence. Chomsky proposes that the identity constraint that these structures fail to satisfy is but a special case of a more general principle, which requires that deletion not take place unless the deleted constituent is recoverable in a sense that is made precise elsewhere in the book. Ross (1967) shows many cases in which metaconstraints on transformations make it possible to move a constituent out of a certain kind of structure. In cases where the movement rule is obligatory, the rule blocks and the sentence is there-
by characterized as ungrammatical. In both Chomsky's and Ross' examples, some metacondition on transformations prevents a particular rule from applying, thereby characterizing the resulting sentence as ungrammatical. The question should therefore be raised of whether all cases of the 'filtering function of transformations' should not involve the blocking of particular transformations by

metaconstraints of one kind or another. That is, linguistic theory should not allow us to impose ad hoc constraints on particular transformations which cause them to 'block' in particular instances, such as would be necessary to characterize the sentences under discussion here as ungrammatical by a blocking of some transformation in their derivational history. These issues are taken up in the Epilogue.

18. It is clear from the examples given here that what is deleted is not in all respects identical to the preceding sentence. For example, in the derivation of (44) from (43), se me permitió dormir toda la mañana is deleted under 'identity' to se le permitió dormir toda la mañana, even though the Dative pronouns are different. However, the nature of the conditions under which such deletion can take place need not concern us here.
19. Note that, strictly speaking, 'one' is an incorrect translation of Pro, since in English one cannot serve as the subject of sentences that require plural subjects. Thus we cannot say, for example, *One surrounded the house.
20. (68) also predicts that the sequence $\text{III}_{\text{Dative}} \text{ I II}$ will be ungrammatical. In fact, there are no grammatical sentences in Spanish with this sequence of clitics. (68) makes a further prediction that the sequence $\text{II I III}_{\text{Dative}}$ is grammatical. I have not been able to find any examples generated by the transformational component which have this sequence of pronouns. (68) predicts that if there are any such examples, they will be grammatical. (68) can therefore be shown to be incorrect by providing an example

with a well-formed deep structure which would emerge from the transformational component with this sequence of clitics and which is ungrammatical.

21. It is now no longer necessary for the spurious se rule to be obligatory, since sentences in which it has failed to apply will be discarded as ungrammatical by the output constraint.
 22. It is necessary to add a minor qualification to this statement. This will be done in what follows, when examples from French are discussed.
 23. This is only part of the output condition chart for clitic pronouns in French. I am ignoring the third person reflexive pronoun se, y, and en, as well as the fact that the first and second person clitic pronouns come after the third person ones in imperatives. It is an interesting question how these additional facts of French should be accounted for, but they do not concern us here. Our purpose here is to show that the notation that we are proposing as a universal for the statement of such constraints is also used in the grammar of French. This point about the notation can be made with reference to only part of the French output condition chart.
-
24. If (77) is the correct form of the output constraint, it will automatically rule out the sequence le lo as ungrammatical. This ungrammaticality could also be characterized by failure of the spurious se rule to apply.

25. It seems that the inventory of elements which can behave as clitics in natural languages is extremely limited. Linguistic theory must account for this fact by incorporating a universal definition of what the possible clitics in natural languages are. In particular languages, the elements which fit the definition may or may not behave as clitics, but in no language can elements which do not fit this definition behave as clitics. For further discussion of this question, see Browne, Hale, and Perlmutter (in preparation).

26. A few combinations that should be ungrammatical are not as bad as others, e.g. ?old pretty houses, ?little pretty houses.

27. There is no way to say 'I escaped from you' and 'We escaped from you' with the Dative of Interest, that is, using the same construction that we find in

(v) Te me escapaste.

'You escaped from me.'

There is another sentence of Spanish that would also be translated into English as 'You escaped from me,' but which uses a directional de-phrase instead of the Dative of Interest. With this construction we get

(vi) Te escapaste de mí.

'You escaped from me.'

And, alongside (vi), we can say

(vii) Me escapé de tí.

'I escaped from you.'

(viii) Nos escapamos de tí.

'We escaped from you.'

These sentences are possible because they do not violate the output constraint (77). But they are very different in meaning from the construction with the Dative of Interest, just as (vi) and (v) differ markedly in meaning. This difference in meaning can perhaps be brought out by contrasting

(ix) El ex-presidente le había sacado mucho dinero a la República.

'The ex-president had taken a lot of money from the Republic.'

(x) El ex-presidente había sacado mucho dinero de la República.

'The ex-president had taken a lot of money out of the Republic.'

(ix) indicates that the former president had stolen money from the Republic, although he had not necessarily taken it outside its borders. (x), on the other hand, conveys the idea of his having taken money outside the country, but there is no intimation of his having gotten it at the expense of the Republic. (vi), like (x), indicates a physical action. (v), on the other hand, like (ix), indicates an action with respect to, or, in this case, at the expense of, the other party, although not necessarily a physical action.

28. This is actually not much different from the rule that would be needed to account for complex sentences as well. For a discussion of these problems, see Browne, Hale, and Perlmutter (in preparation).

29. Elson and Pickett (1965), p. 57.

30. The inability of tagmemics to account for Spanish object pronouns in terms of tagmemes is but a particular consequence of its failure to distinguish between deep and surface structure. In a theory which makes this distinction, information about the grammatical relations and functions of constituents is represented at the level of deep structure. If it then turns out, as it has in Spanish, that the arrangement of certain constituents in surface structures carries no information about their grammatical relations and functions, this information has still been represented at some level. But a theory which does not distinguish between deep and surface levels of representation has no way to represent this information in a case such as that of the Spanish clitic pronouns where the arrangement of constituents in surface structure in no way reflects grammatical relations or grammatical function. For this reason, tagmemics is not alone in its inability to account for both grammatical relations and the positioning of object pronouns in Spanish. This failure it shares with all theories of language which make no distinction between deep and surface levels of representation.

CHAPTER FIVE

A Typological Difference Among Languages

In French one may question any object or adverbial constituent of a subordinate clause introduced by que.

- (1) a. Qui a-t-il dit que Martin avait envie de mordre?
'Who did he say that Martin felt like biting?'
- b. À qui a-t-il dit que Nicole a donné le grisbi?
'Who did he say that Nicole gave the loot to?'
- c. Où a-t-il dit que les copains avaient caché la cuillère?
'Where did he say that the guys had hidden the spoon?'
- d. Quand a-t-il dit que les flics viendraient?
'When did he say that the cops would come?'

However, it is impossible to question the subject of such a subordinate clause.

- (2) *Qui a-t-il dit que s'est évanoui?
'Who did he say (that) fainted?'
- (3) *Qu'a-t-il dit que s'est passé?
'What did he say (that) happened?'

The same thing happens under relativization. We may relativize any object or adverbial constituent in such subordinate clauses, but we may not relativize the subject.

- (4) a. la speakerine qu'il a dit que Martin avait envie de mordre
'the announcer that he said that Martin felt like biting!'
- b. le salaud à qui il a dit que Nicole a donné le grisbi
'the bastard that he said that Nicole gave the loot to'
- c. le pays où il a dit que les copains avaient caché la cuillère
'the country where he said that the guys had hidden the spoon'

d. 1'heure qu'il a dit que les flics viendraient
'the time that he said that the cops would come'

(5) *la speakerine qu'il a dit que s'est évanouie
'the announcer that he said (that) fainted'

(6) *les événements qu'il a dit que se sont déroulés
'the events which he said (that) took place'

It would appear at first glance that we must impose a special constraint on movement transformations such as Question Formation and Relativization in French which prevents them from moving the subject, and only the subject, out of subordinate clauses introduced by que. We will here propose a different solution - that the grammar of French contains the following surface structure constraint:

(7) Any sentence other than an Imperative in which there is an S that does not contain a subject in surface structure is ungrammatical.

This constraint applies to examples like (5) in the following way. Before the application of the relativization transformation, the structure underlying (5) looks something like this:

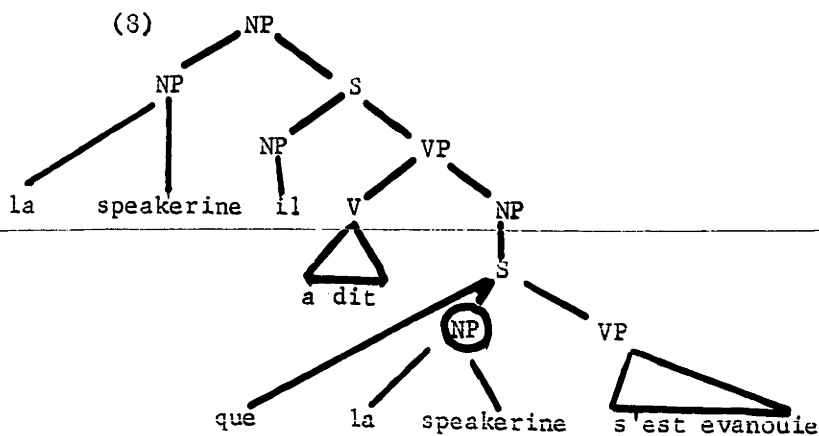

The relativization rule pronominalizes la speakerine, the circled NP in (8), and moves it to the front of the relative clause,¹ producing a

derived structure like:

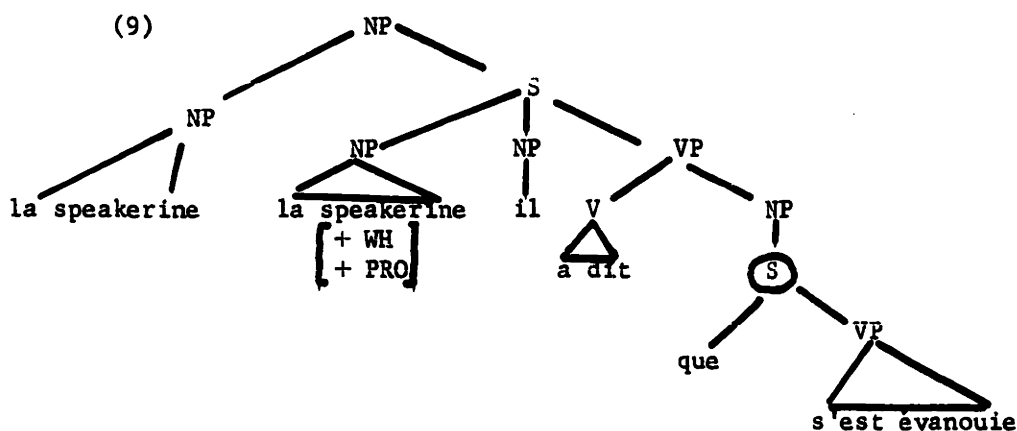

When the surface structure constraint (7) applies, the embedded (circled) sentence in the relative clause has no subject, and the sentence is discarded as ungrammatical. In examples like those in (4), on the other hand, it is not the subject of an embedded sentence that is moved to the front of the relative clause. When the constraint (7) is applied, there is a subject in each S in the tree. These examples therefore qualify as grammatical. The surface structure constraint (7) therefore accounts for the fact that sentences like *(2-3) and *(5-6), in which an embedded subject has been relativized or questioned, are ungrammatical, while sentences like (1) and (4), in which some constituent other than the subject has been relativized or questioned, are fully grammatical. It does this without making it necessary to place ad hoc constraints on the Relativization and Question Formation transformations in order to prevent the subject - and only the subject - of a subordinate clause from undergoing these rules.

The surface structure constraint (7) also accounts for another fact of French which, without (7), would be a completely unrelated phenomenon. This is the fact that subject pronouns in French can not be deleted. It is often said that those languages which allow deletion of subject pronouns allow it because they have sufficient inflection to make

the deleted subject recoverable. This is often true in French, yet the resulting sentences are ungrammatical.

- (10) a. *Avons travaillé toute la journée.
'(We) worked all day long.'
- b. *Êtes parti trop tôt, it paraît.
'(You) left too early, it seems.'
- c. *Ont mangé la soupe sans cuillère.
'(They) ate the soup without a spoon.'

And other languages allow deletion of subject pronouns even where ambiguity results. In Italian, for example, we find

- (11) Sono qui.
'I am here; They are here.'

The fact that subject pronouns in French can not be deleted can not be explained by a theory which claims that this happens only where there is sufficient inflection to prevent ambiguity. This fact can be explained, however, by the constraint (7).

Our hypothesis entails the claim that the ungrammaticality of sentences like *(2-3) and *(5-6), on the one hand, and the ungrammaticality of sentences like those in *(10), on the other, are different aspects of the same phenomenon; it is claimed that all of these sentences are rejected as ungrammatical by the surface structure constraint (7). Now let us put this theory to the crucial test. If it is correct, it should be the case that in languages which allow deletion of subject pronouns - languages in which sentences like *(10) are grammatical - sentences like *(2-3) and *(5-6) will be grammatical as well.² We will use Spanish as an example of such a language, since in Spanish sentences like *(10) without subject pronouns are grammatical:

(12) Hemos trabajado todo el día.

'(We) have worked all day.'

And our prediction is borne out: in Spanish it is possible to question or relativize the subject of an embedded sentence.

(13) ¿Quién dijiste que salió temprano?

'Who did you say (that) left early?

(14) ¿Qué dijiste que pasó?

'What did you say (that) happened?'

(15) el tipo que dijiste que salió temprano

'the guy that you said (that) left early'

(16) las cosas que dijiste que pasaron

'the things that you said (that) happened'

We now have a hypothesis according to which French differs from Spanish in that the grammar of French has the surface structure constraint (7), while the grammar of Spanish has no such constraint. This constraint simultaneously accounts for two otherwise separate facts - the deletability of subject pronouns and the ability to question or relativize the subject of an embedded sentence - by means of a single constraint.

This surface structure constraint not only accounts for the correlation between the ability to question or relativize the subject of an embedded sentence and the deletability of subject pronouns, it also accounts for a wide range of other phenomena which represent systematic differences between French and Spanish. The constraint (7) makes the claim that no sentence of French is grammatical unless it has a subject in surface structure. It therefore explains why it is that French has an expletive subject in a wide range of different constructions. Spanish, on the other hand, has no surface structure constraint that requires

the presence of a subject in surface structure, and it does not have expletive subjects.

The expletive il in French appears in a wide range of different constructions. In each case, there is no corresponding surface structure subject in Spanish. We list below some of the constructions in which this systematic difference between the two languages can be seen.

In sentences with weather verbs, we find il as surface structure subject in French.

(17) Il pleut.

'It's raining.'

(18) Il fait beau temps.

'It's nice weather out.'

In Spanish, the verb appears without any surface structure subject.

(19) Llueve.

'It's raining.'

(20) Hace buen tiempo.

'It's nice weather out.'

No surface structure subject is possible with these expressions in Spanish.

(21) a. *Él llueve.

b. *Ello llueve.

In French, expletive il appears in sentences which have an extra-posed sentential subject.

(22) Il est évident que l'impérialisme suédois est à bout de souffle.

'It is clear that Swedish imperialism is on its last legs.'

In Spanish, such sentences have no subject in surface structure.

(23) Es evidente que no pasarán.

'It is clear that they won't get through.'

We find the same thing in expressions of time, in which French again uses expletive il as a dummy subject in surface structure.

(24) Il est tard.

'It's late.'

The corresponding Spanish sentence has no surface structure subject at all.

(25) Es tarde.

'It's late.'

(24) would be ungrammatical without a surface structure subject, while

(25) would be ungrammatical if a dummy pronoun were put in.

It might be argued that these facts can be accounted for simply by postulating a transformation in French that introduces the dummy subject il in sentences which lack a subject late in derivations. This is inadequate, however, for two reasons. First, the dummy subject in French is not always il, but is sometimes ce.

(26) C'est beau les montagnes.

'Mountains are beautiful.'

(27) C'est étonnant le nombre de gens qui mangent à l'américaine.

'It's amazing the number of people who eat American style.'

Assuming that the distribution of il and ce can be stated transformationally, it would require at least two transformations to insert the appropriate dummy subjects. Second, and much more important, transformations which introduce dummy subjects into sentences which lack a subject in surface structure can not also account for the fact that subject pronouns can not be deleted in French, or the fact that the subject of a subordinate clause can not be questioned or relativized. It is the correla-

tion of these three sets of facts that is explained by the surface structure constraint (7).

The question of whether the dummy subjects il and ce in French are transformationally introduced or present in deep structure will be left open here, since it is not directly relevant to our hypothesis. Let us consider each of these two possibilities in turn, and determine the status of our hypothesis in each case.

If the dummy subjects are present in deep structure, our hypothesis explains why they can not be deleted in French, in exactly the same way that it explains why subject pronouns can not be deleted in French.

If, on the other hand, the dummy subjects are not present in deep structure but rather are transformationally introduced, our hypothesis explains why French has transformations which introduce such dummy subjects into surface structures. It does this in the following way. There are sentences - (17), (18), and (24), for example - for which there is no evidence for the presence of any subject at all in deep structure. In languages like Spanish, which lack the constraint (7), there is no evidence for such sentences' having a subject at any stage of derivations. There are other sentences, such as (22), which have no subject once the Extraposition transformation has applied. This is so because, since we are now assuming that the dummy subjects are not present in deep structure, the deep structure of (22) looks like

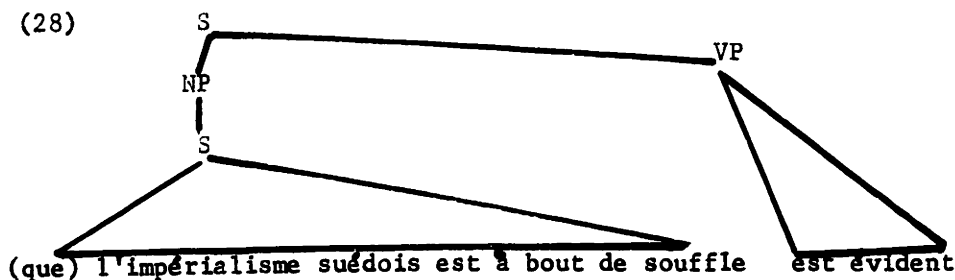

Since the Extraposition transformation moves a subject S to the end of the sentence, the application of Extraposition produces a derived constituent structure like

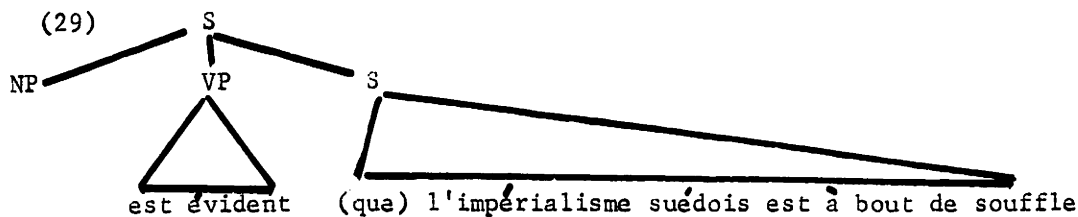

in which there is no subject. Now, if the grammar of French includes the surface structure constraint (7), sentences like (17), (18), (24), and (22) will be ruled out as ungrammatical, unless the grammar also contains transformations which insert dummy subjects into these sentences prior to the application of the constraint (7). The presence of (7) in the grammar of French does not require that the grammar contain rules to provide sentences like (17), (18), (24), and (22) with dummy subjects. It does entail, however, that if the grammar does not have any such rules, there will be no way to actualize the deep structures of any of these sentences grammatically. Our hypothesis does not predict that this situation can not arise. It predicts only that if sentences of this type are grammatical in a language for which the surface structure constraint (7) is motivated on independent grounds, then such sentences will have dummy subjects in surface structure.

The form of explanation here is somewhat different from that which we generally find in the literature on generative grammar. Our hypothesis does not explain why certain sentences are grammatical, but rather why grammatical sentences contain subjects in surface structure in French - that is, why grammatical sentences have the form that they do. The surface structure constraint (7) is an explanatory hypothesis which explains why it is that in French there are sentences with dummy subjects, subject pronouns can not be deleted, and the subjects of subordinate clauses can not be questioned or relativized. It explains why we find these facts rather than others by means of the requirement that in French each S must have a subject in surface structure.

As a result, the explanatory power of our hypothesis extends beyond the domain of expletive subjects like il and ce in French. It also explains why an underlying Pro subject⁴ is spelled out as a subject in surface structure in French. We are referring to the formative on, which is a subject in surface structure. It occurs in subject position in sentences like

(30) On veut que la Nouvelle Angleterre soit libre et indépendante.

'Pro wants New England to be free and independent.'

and it behaves like a subject in that it inverts with the verb in question.

(31) Veut-on que la Nouvelle Angleterre soit libre et indépendante?

'Does Pro want New England to be free and independent?'

In Spanish, on the other hand, an underlying Pro subject is spelled out as impersonal se. As we saw in Chapter Four, impersonal se behaves like an object pronoun in surface structure, positioning itself next to the verb with the other object pronouns.

(32) Se quiere que la Nueva Inglaterra sea libre y independiente.

'Pro wants New England to be free and independent.'

(33) se te permitio' dormir toda la mañana.

'Pro allowed you to sleep all morning; i.e., 'You were allowed to sleep all morning.'

As a result, Spanish sentences like (32) and (33) which have a Pro subject in deep structure have no subject at all in surface structure. The fact that sentences like (31) have a surface structure subject in French, while the Spanish counterpart (32) lacks a surface structure subject, is another manifestation of the systematic difference between French and Spanish that is under discussion here. This difference is explained by our hypothesis, according to which the grammar of French has the surface structure constraint (7), while the grammar of Spanish does not.

It follows from the nature of our hypothesis that it makes claims about French but not about Spanish. Since it postulates the constraint (7) in the grammar of French, the existence of grammatical sentences in French other than imperatives which lack a surface structure subject would force us to modify or abandon (7). By the same token, it is only for French that our hypothesis has any explanatory power, since nothing whatsoever is being said about a language like Spanish which does not have the constraint (7) in its grammar. A language which has no such surface structure constraint could, for example, have a transformation which introduces expletive subjects in various sentences, but, lacking the constraint (7), there is no reason for it to have such a rule. The fact is that most languages which have no such surface structure constraint also have no expletive subjects in surface structure.

It seems that a large number of languages are like Spanish in that they have no constraint like (7) in their grammars. They therefore

allow questioning and relativization of the subject of a subordinate clause,⁵ they allow deletion of subject pronouns,⁶ and they generally lack expletive subjects in surface structure. The languages in this category include Italian, Serbo-Croatian, Arabic, Hebrew, Hausa, Walbiri, and Basque.⁷

It is more difficult to find languages which, like French, have the constraint (7) in their grammars. In some cases it is more difficult to establish whether there is motivation for (7) in a particular language. In English, for example, we find the same restriction that we found in French on relativization or questioning of the subject of a subordinate clause introduced by that. We may question any constituent of such subordinate clauses except the subject.

- (34) a. What did he say that Laura hid?
 b. Where did he say that Laura hid the rutabaga?
 c. When did he say that Laura hid the rutabaga?
- (35) *Who did he say that hid the rutabaga?
- (36) *What did he say that happened?

It is the same with relativization.

- (37) a. the rutabaga that he said that Laura hid
 b. the place where he said that Laura hid the rutabaga
 c. the day that he said that Laura hid the rutabaga
- ~~(38) *the woman that he said that hid the rutabaga~~
- (39) *the events that he said that happened

But whereas there is no way to make sentences like *(35), *(36), *(38), and *(39) grammatical in French, they are grammatical in English if the complementizer that is deleted.

- (40) Who did he say hid the rutabaga?
 (41) What did he say happened?
 (42) the woman that he said hid the rutabaga
 (43) the events that he said happened

The question before us is how these facts in English are to be accounted for. Does the grammar of English include the surface structure constraint (7), or can these facts be explained in some other way?

One alternative would be to order the that-deletion rule to follow Relativization and Question Formation and to place a condition on it such that although it is an optional rule, it is obligatory if that is immediately followed by a VP. The that-deletion transformation would then relate pairs of sentences like

- (44) a. He said that no one would ever find him
 b. He said no one would ever find him.

by means of its optionality. But if the subject of an embedded sentence had been removed by Relativization or Question Formation, that-deletion would be obligatory, and *(35), *(36), *(38), and *(39) would be converted into the grammatical (40), (41), (42), and (43) respectively.

Another possibility would be to say that there are two rules which delete the complementizer that. One would be an optional rule, and would relate pairs of sentences like (44a) and (44b). The other rule would apply not only to that, but to all complementizers in English, and would obligatorily delete any complementizer that is immediately followed by a VP. This rule would purport to express a generalization to the effect that complementizers do not occur before a VP in English. As a result, *(35), *(36), *(38) and *(39) would, by this means as well, emerge as the grammatical sentences (40), (41), (42), and (43) respectively.

What these two proposals have in common is that they find some way of getting grammatical sentences out of *(35), *(36), *(38), and *(39). We can show that they are both wrong by finding examples where the that simply can not be deleted. This is the case with the verb allow, as can be seen in:

- (45) a. Clyde allowed that Henrietta likes spumoni.
 b. *Clyde allowed Henrietta likes spumoni.

With allow, as in the example we have already considered, we get a grammatical sentence if we question any constituent of the subordinate clause except the subject.

- (46) What did Clyde allow that Henrietta likes?
 (47) *Who did Clyde allow that likes spumoni?

If the counter-proposals outlined above were correct, the following sentence would be grammatical.

- (48) *Who did Clyde allow likes spumoni?

It is the same with relative clauses. We may relativize anything but the subject of the subordinate clause.

- (49) the kind of spumoni that Clyde allowed that Henrietta likes
 (50) *the girl that Clyde allowed that likes spumoni

If the counter-proposals above were correct, the following example would be grammatical.

- (51) *the girl that Clyde allowed likes spumoni

Since neither *(48) nor *(51) are grammatical, the counter-proposals above are incorrect. It is not the case that the complementizer that is obligatorily deleted before a VP. We must now be able to rule out as ungrammatical not only *(35), *(36), *(38), and *(39), but also *(47) and *(50). The surface structure constraint (7) does just that. We conclude that

this surface structure constraint is part of the grammar of English.

A similar example which shows that this constraint is needed in the grammar of English is provided by sentences like

(52) a. It must be the case that Clarita robs churches.

b. *It must be the case Clarita robs churches.

Since that can not be deleted after the case, we can construct a similar argument for (7) based on sentences with the case. We find that we can question or relativize any constituent of the embedded sentence except the subject.

(53) What must it be the case that Clarita robs?

(54) *Who must it be the case that robs churches?

If that-deletion were obligatory, as the two counter-proposals above would have it, the following sentence would be grammatical:

(55) *Who must it be the case robs churches?

Since it is not, the counter-proposals above are incorrect, and the surface structure constraint (7) must be included in the grammar of English.

There may be some variation from one speaker to another with regard to the deletability of that with allow and the case. All that is needed to motivate (7) for a given dialect is to find a verb or expression which allows questioning and relativization from subordinate clauses embedded beneath it, and which does not allow deletion of that after it.

~~The argument is then as given above for allow and the case.~~

Now that we have included the surface structure constraint (7) in the grammar of English, we find that it automatically accounts for what would otherwise be a mysterious limitation on movement of constituents out of in order for clauses. For example, consider a sentence like

- (56) Sarah worked for six months in order ~~for~~ that man to be able to buy a car.

We can question or relativize a noun phrase in object position in the in order for clause, as in

- (57) the car that Sarah worked for six months in order for that man to be able to buy

But we may not relativize or question a noun phrase in subject position.

- (58) *the man that Sarah worked for six months in order for to buy a car

Since the in order for clause contains a full sentence (although the verb is in infinitival form), there is no reason for it not to be dominated by an S-node. In the case of *(58), then, we have moved the subject out of the clause, leaving an S in surface structure which does not contain a subject. The constraint (7) therefore rejects it as ungrammatical. In the case of (57), on the other hand, it is the object that is moved, (7) is not violated, and the result is grammatical. The constraint (7) thus accounts for the difference in grammaticality between (57) and *(58). Note also that if the counter-proposal discussed above were correct, and complementizers were obligatorily deleted before a VP in English, thereby accounting for the grammaticality of (40-43), then the complementizer for in *(58) should be deleted, and the result should be grammatical. But it is not:

- (59) *the man that Sarah worked for six months in order to buy a car

This counter-proposal can not account for examples like these, while the surface structure constraint (7) does.

With the surface structure constraint (7) in the grammar of English, ungrammatical sentences like *(35), *(36), *(38), *(39), *(47), *(50), and *(58) are correctly rejected as ungrammatical. However, the sentences

(40-43) must not be ruled out by (7) as ungrammatical, since they are perfectly grammatical. In order to account for these examples, we must assume that when that is deleted, the S-node above the embedded sentence is pruned away.⁸ Then, when the surface structure constraint checks each S in the tree to make sure that it has a subject, there will be no S-node above the embedded sentence, and it will consequently not be rejected as ungrammatical. The derived constituent structure of *(38), then, would look something like this:

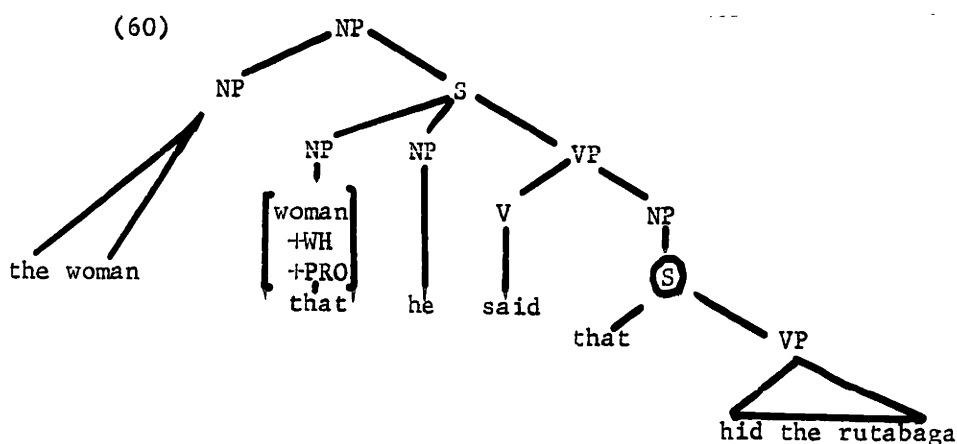

that has not been deleted, and the S-node that is circled consequently remains above the embedded sentence. The surface structure constraint (7) finds that this tree contains an S which lacks a subject in surface structure, and consequently rejects it as ungrammatical. If that has been deleted, on the other hand, this S-node is pruned away, and the derived constituent structure looks something like this:⁹

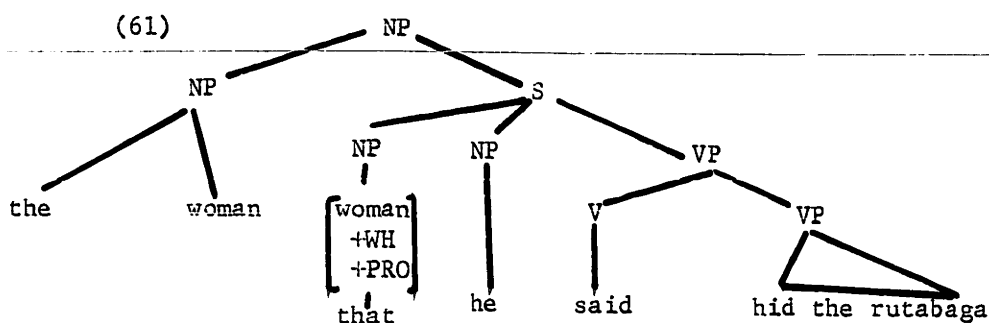

The tree contains no S's which lack a subject, and it is consequently not rejected as ungrammatical by (7). Aside from the necessity of accounting for the difference in grammaticality between sentences like *(38) and those like (42), we have no other evidence that deletion of that causes pruning.

Ross (1967) proposes a general condition according to which pruning of S-nodes occurs whenever an S-node does not branch, that is, whenever it dominates only one constituent. The examples given in support of this are cases where an S-node is pruned due to the deletion of the subject of an embedded sentence by Equi-NP Deletion, and cases where what begins as an entire embedded sentence in deep structure ends up as just a single constituent in surface structure. This is the case when a relative clause is reduced to just an adjective, and when a full sentence is reduced to just a noun phrase by Comparative Reduction, to produce sentences like

(62) Joe is faster than Pete.

We are proposing here that that-deletion causes pruning, converting (60) to (61). Ross has pointed out to me that it is possible to preserve the generalization that only S-nodes which do not branch are pruned. In a structure like (60), it is because of the presence of that that the S-node continues to branch. As soon as that is deleted, the circled S-node no longer branches, and is consequently pruned away. If this is correct, that-deletion does not cause pruning by itself; it is only when the deletion of that results in an S-node that does not branch that pruning takes place. This hypothesis accounts for the grammaticality of (40-43). It also entails that in sentences like

(63) It is obvious the electorate is gullible.

(64) The candidates know the electorate is gullible.

there is an S-node above the electorate is gullible in surface structure.

This seems correct, although we have no direct evidence to support it.¹⁰ However, if that-deletion by itself causes pruning whenever it applies, we need a new and ad hoc condition on the theory of pruning, while if that-deletion causes pruning only when it results in an S-node that does not branch, the theory of pruning does not need to be modified for these cases. For this reason, we will tentatively assume that that-deletion causes pruning only when it results in an S-node that does not branch. At any rate, it is clear that deletion of the that complementizer in sentences like (40-43) must cause pruning of the S-node above the embedded sentence prior to the application of the surface structure constraint (7).

Having incorporated (7) into the grammar of English, we find that it automatically accounts for an entirely different set of facts. Note that in French noun phrases with a relativized subject are grammatical.

- (65) l'homme qui est venu hier soir
'the man who came last night'

The derived structure of (65) looks something like

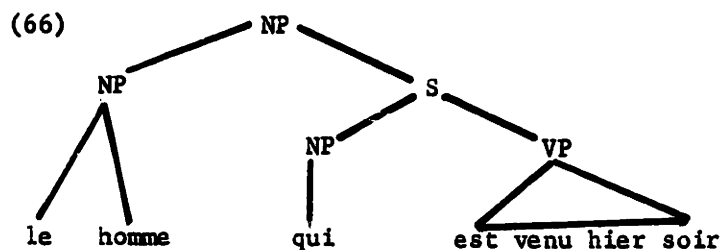

The point that is of importance here is the fact that the relative pronoun qui is a subject pronoun, dominated by an NP-node in (66). The embedded sentence in (66) therefore has a subject, the constraint (7) is satisfied, and (65) is grammatical. Recall that the morpheme que in (9) was not a subject pronoun dominated by NP, but rather a complementizer dominated directly by S. The embedded S in (9) therefore lacked a subject, and was rejected by (7) as ungrammatical.¹¹

In English, noun phrases with relative clauses in which the subject has been relativized are also grammatical.

(67) the man who loves Marie

The derived structure of (67) is something like

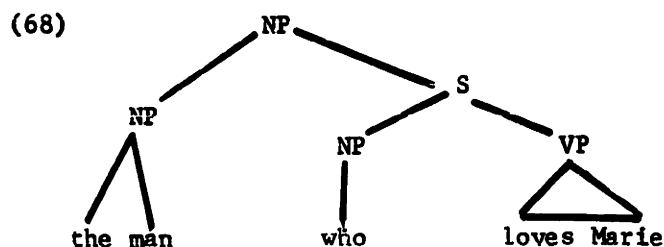

and, as is the case with qui in French, the relative pronoun who is a subject dominated by an NP-node, the constraint (7) is satisfied, and (67) is therefore grammatical. If it is the object of a relative clause that is relativized, as in

(69) the man who Marie loves

we have a derived structure like

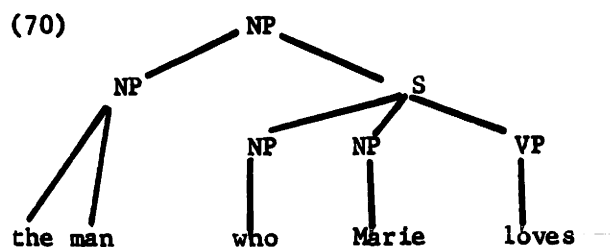

Now, the grammar of English includes a transformation, discussed in Smith (1961), (1964), which optionally deletes the relative pronoun.¹² Thus the noun phrase in (70) can appear in sentences like

(71) I met the man Marie loves.

in which who has been deleted. But if we do the same thing to the noun phrase in (68), we get an ungrammatical sentence.

(72) *I met the man loves Marie.

What is of interest here is the fact that the surface structure constraint

(7), motivated on independent grounds, automatically predicts that *(72) will be ungrammatical. For if we delete the relative pronoun who in (68), we end up with an S which lacks a subject:

(73)

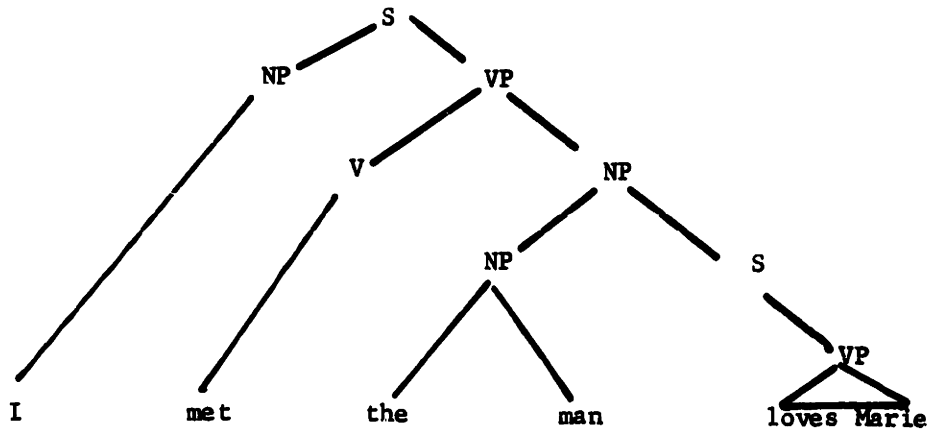

The surface structure constraint (7) will reject (73) as ungrammatical. In order for this to happen, however, the embedded S-node in (73) must not be pruned, even though it does not branch. This is therefore evidence that the failure to branch of an S-node is a necessary but not sufficient condition for pruning. No S-nodes which do branch are pruned, but some which do not, as in (73), are not pruned. The main point of interest here, however, is that the inclusion of (7) in the grammar of English correctly predicts that *(72) will be ungrammatical. In the case of (70), on the other hand, the deletion of the relative pronoun who yields the derived structure

(74)

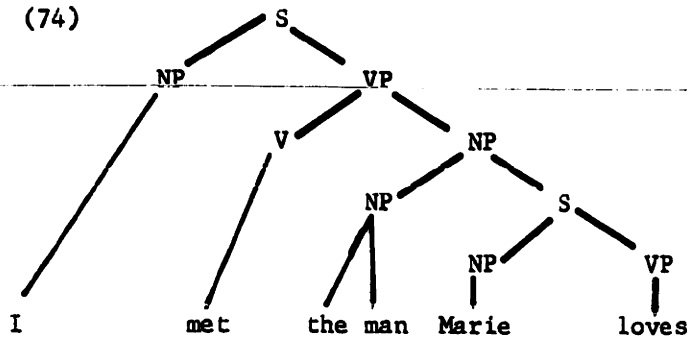

in which the embedded sentence contains a subject. (74) therefore satisfies the constraint (7) and qualifies as grammatical.

What is of interest here is the fact that once we had motivated the surface structure constraint (7) on independent grounds - principally the ungrammaticality of *(47), *(54), and *(58) - we find that it automatically accounts for the ungrammaticality of sentences like *(72). This means that it is not necessary to put a special condition on the transformation which deletes the relative pronoun, as was proposed in Smith (1964), to prevent it from applying if the relative pronoun is followed by a verb or by be followed by a noun phrase. The relative reduction transformation can now operate freely, but in those cases where it produces a derived structure which contains an S which lacks a subject, the sentence will be rejected as ungrammatical by the surface structure constraint (7).¹³

Now that we have motivated (7) for English, we have an explanation for other phenomena in English, as we did in French. We now explain why it is that subject pronouns can not be deleted in English, although there are many instances in which the verb is sufficiently inflected to make the result completely unambiguous.¹⁴

(75) *Am making good progress.

(76) *Is spending the summer in Vermont.

(77) *Tries to please his mother-in-law.

We also have an explanation for the various dummy subjects we find in grammatical English sentences.

(78) It is raining.

(79) It is conceivable that electoral politics could be a vehicle for effecting social change.

(80) It is five o'clock.

(81) It's me.

(82) There is a daffodil under the pillow.

Leaving open the question of whether these dummy subjects are present in deep structure or transformationally introduced,¹⁵ the surface structure constraint (7) is an explanatory hypothesis which explains why all grammatical English sentences have some kind of subject in surface structure - that is, why they have the form that they do.

We will refer to languages such as French and English, which have the surface structure constraint (7) in their grammars, as Type A languages. Languages which do not have this surface structure constraint we will call Type B languages. These include Spanish, Italian, Serbo-Croatian, Arabic, Hebrew, Hausa, Walbiri, and Basque. Given our definition of Type A and Type B languages, every language must be either of one type or the other.

We have been careful to characterize languages as Type A only if the surface structure constraint (7) is needed in their grammars to reject as ungrammatical any sentences in which the subject of a subordinate clause has been relativized or questioned. Since our hypothesis makes no claims about Type B languages, which do not have the constraint (7), it would not contradict our hypothesis if we found a Type B language in which subject pronouns can not be deleted and which has expletive subjects like French il and English it and there. Under our hypothesis, these facts would be accidental in a Type B language, whereas they are necessary and therefore explained in a Type A language. It seems that Dutch is just such a language. In Dutch, sentences like

(83) Wie vertelde je, dat gekomen was?

'Who did you say (that) had come?'

in which the subject of a subordinate clause introduced by dat ('that')

has been moved away by Question Formation, are perfectly grammatical. On the basis of the grammaticality of (83), we must classify Dutch as a Type B language. Now, it happens that in Dutch subject pronouns can not be deleted, and the language has the expletive subjects het and er which function much like it and there do in English. Under our hypothesis, these facts of Dutch are accidental. It is of course possible that these facts of Dutch are not accidental, and could be captured by a theory superior to the one proposed here, just as it is also possible that they are accidental and therefore predictable by no general theory. For the present, since we have no theory which predicts that Dutch must exhibit these facts, they remain accidental facts, and therefore are fundamentally different from the analogous facts in French and English, for which our hypothesis predicts that, given the ungrammaticality of sentences in which the subject of a subordinate clause has been removed, the language must have expletive subjects and can not have deletion of subject pronouns. Whereas these facts in French and English are explained by our hypothesis, the same facts in Dutch are not.

If our hypothesis is correct, it gives us a way to determine where there are S-nodes in derived constituent structure in Type A languages. When we find that any constituent can be moved out of an embedded sentence, we will assume that that embedded sentence is no longer dominated by an S-node in surface structure. When we find that any constituent of an embedded sentence except the subject can be moved out, we will assume that that embedded sentence is still dominated by an S-node in surface structure, and that those sentences in which the subject has been moved out owe their ungrammaticality to the surface structure constraint (7). The grammaticality or ungrammaticality of sentences with an embedded sentence

from which the subject has been removed by Question Formation or Relativization thus tells us in which constructions the S-node above an embedded sentence remains in surface structure, and in which constructions it does not. In other words, it supplies us with some empirical facts which an adequate theory of tree-pruning must be able to account for.

Consider a dialect of English which, like my own, exhibits the following paradigms:

- (84) a. I hate it for Lucille to sing Dixie.
 b. I hate for Lucille to sing Dixie.
 c. *I hate Lucille to sing Dixie.
- (85) a. *I expect it for Lucille to sing Dixie.
 b. *I expect for Lucille to sing Dixie.
 c. I expect Lucille to sing Dixie.

Assuming a deep structure for these sentences like the one proposed by Rosenbaum (1967), we have:

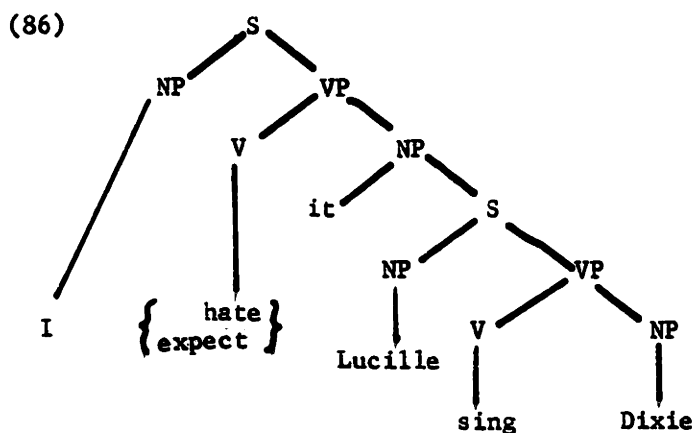

With the verb expect the subject of the embedded sentence undergoes It- Replacement, being substituted for the it dominated by the NP which immediately dominates the embedded S, while the embedded S itself is brought under the domination of the matrix VP. This results in a derived structure like

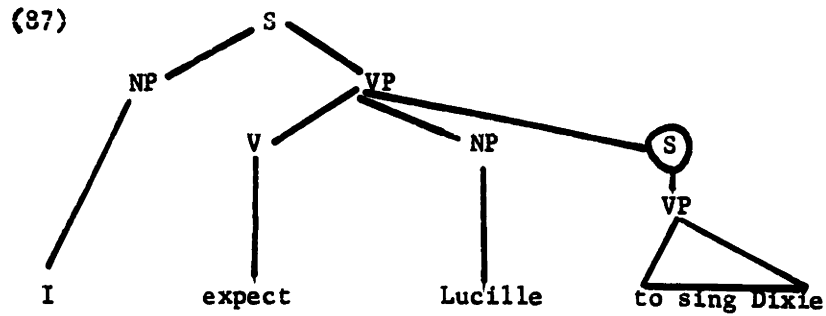

At this point we must make use of Ross' condition for pruning - that the embedded (circled) S-node in (87), which dominates only one constituent, must be pruned. This gives us the derived structure

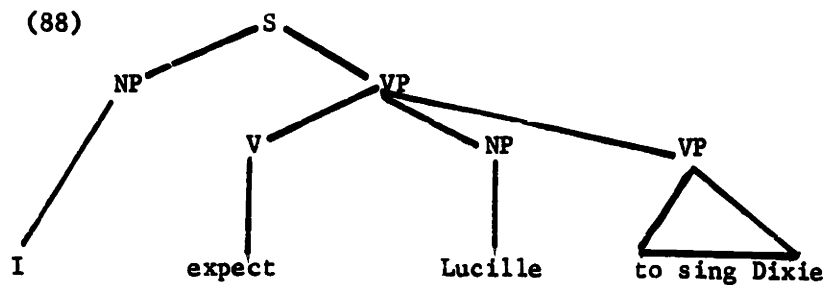

The crucial aspect of this derived structure is that Lucille is now the object of expect in the matrix sentence. With hate, on the other hand, It-Replacement does not apply, with the result that Lucille remains in the embedded sentence in a derived structure which is essentially the same as the deep structure (86).

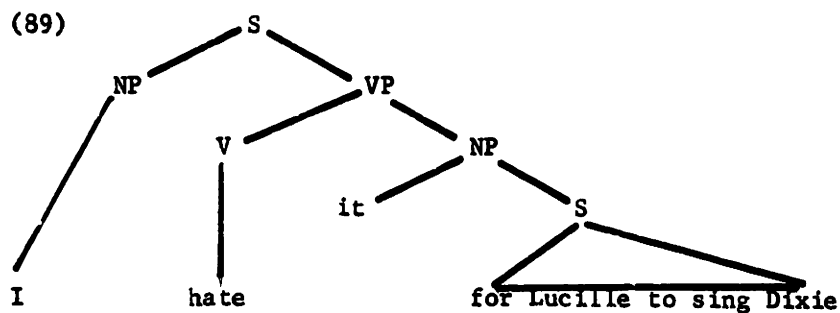

An optional rule can then delete the it in sentences with hate, thereby producing (84b) from the structure underlying (84a).

This analysis accounts for the inability of it to occur in object position with expect and a complement sentence by means of a rule which substitutes the subject of the embedded sentence for this it. With hate the it can occur, hence the subject of the embedded sentence can not be substituted for it. Since under this hypothesis the subject of the embedded sentence ends up in the matrix sentence with expect but not with hate, we can test this hypothesis by seeing whether it accords with the facts of reflexivization. As Lees and Klima (1963) have shown, the reflexivization transformation applies only within a single S. If the hypothesis sketched above is correct, then, reflexive pronouns should be grammatical in the position of Lucille in (85c), but not in (84a) or (84b). And this is the case. The sentence

(90) Fred expects himself to be nominated.

is perfectly grammatical. But sentences like

(91) a. *Fred hates it for himself to be nominated.

b. *Fred hates for himself to be nominated.

are ungrammatical. The differential ability of reflexive pronouns to occur in (90) and *(91) confirms that with expect the embedded subject is raised into the matrix sentence, as shown in (88), but with hate it remains in the lower sentence, as in (89).

Having established that (88) and (89) show the correct derived constituent structure for (85) and (84) respectively,¹⁶ we can now observe how these sentences behave under Question Formation and Relativization. In both cases we can question an object of sing.

(92) What do you expect Lucille to sing?

(93) a. What do you hate it for Lucille to sing?

b. What do you hate for Lucille to sing?

But if we try to question a noun phrase in the position of Lucille in these sentences, the resulting sentence is grammatical in the case of expect, but not in the case of hate.

(94) Who do you expect to sing Dixie?

(95) a. *Who do you hate it for to sing Dixie?

b. *Who do you hate for to sing Dixie?

Since in the dialect under discussion for never deletes with hate, the sentence

(96) *Who do you hate to sing Dixie?

is also ungrammatical. The ungrammaticality of *(95), which would otherwise be a strange aberration, is explained by the surface structure constraint (7). By moving a noun phrase in the position of Lucille in (89) out of the embedded sentence, we are leaving an S which does not contain a subject. The constraint (7) will therefore reject the sentence as ungrammatical. In the case of (94), however, the noun phrase that is questioned is in the matrix sentence, as shown in (88). Moving this noun phrase out does not leave an S without a subject, and the sentence is grammatical. The derived constituent structures (88) and (89), which were motivated on independent grounds, combined with the surface structure constraint (7), automatically predict the difference in grammaticality between (94) and *(95).

In this discussion we have made use of Ross' condition that an S-node is pruned if it does not branch. The notable exception to this is the case of reduced relative clauses, for which it is crucial that the embedded S-node which does not branch not be pruned, if we are to use the surface structure constraint (7) to characterize the ungrammaticality of sentences like *(72). I have no explanation of why pruning does not occur in such cases. What has been said here affects the theory of pruning insofar as examples like *(72) indicate that for an S-node not to

branch is a necessary but not sufficient condition for pruning. We have also tried to show that in Type A languages the surface structure constraint (7) can be used as a means of discovering where S-nodes in fact do and do not remain in surface structure. The constraint (7) thus provides us with facts which a general theory of pruning must be able to account for.

We have said nothing about the level of derivations at which the surface structure constraint (7) applies. Since it may be difficult to identify the subject of a sentence after certain late transformations such as subject-verb inversion in questions and various stylistic reordering transformations have applied, the constraint (7) may have to apply at some level prior to final output. The interesting question of whether there is some such level as 'shallow structure' at which certain constraints must be stated will be left open here.¹⁷

It has been our purpose in this chapter to show that there are languages which have the surface structure constraint (7) in their grammars, and that the presence or absence of this constraint in the grammars of particular languages forms the basis for a typological division among languages. The examples used have been confined to languages with which I am more or less familiar, but languages of Type B, at least, seem to be very common and widespread. I know of no other languages which are clearly of Type A, but I hope that any readers of this thesis who are familiar with such languages will inform me of them.

Since languages can differ typologically according to whether or not they have the constraint (7) in their grammars, it follows that the addition of this constraint to the grammar, or the loss of it, is a conceivable form of linguistic change. The case of French shows clearly that the addition of the constraint (7) to the grammar of a language actually

is possible as a form of linguistic change. Latin was a Type B language, as are the other Romance languages with which I am familiar. At some point in the history of French, then, the constraint (7) must have been added to the grammar. According to our hypothesis, ~~once~~ this constraint was added to the grammar, it was impossible to move the subject out of a subordinate clause, subject pronouns could not be deleted, and the various constructions that we examined required expletive subjects, as is the case in modern French.

It is not at all clear just how such a process of linguistic change takes place, and for this reason the case of French would make an interesting historical study. Under our hypothesis, it is possible for a Type B language to have expletive subjects and to lack a rule which deletes subject pronouns. As we have seen, this is the case in contemporary Dutch. It is possible that French was at some stage like contemporary Dutch in this respect, and that the constraint (7) was then added to the grammar.

This brings us to the interesting question of what it is in the primary linguistic data that leads the language-learning child to put the surface structure constraint (7) in his grammar. Otherwise put, what conditions must be fulfilled in order for the most highly valued grammar of a language to include the constraint (7)? What was there in the data of French at the relevant stage of its history that caused the constraint (7) to be added to the grammar? Whatever the answer to this question is, parallel data must be lacking in contemporary Dutch, which lacks this constraint. An explanatory theory of language must be able to answer questions of this kind.

The constraint (7) is also interesting because it shows that surface structure constraints are not confined to essentially word-level

phenomena such as the order of clitic pronouns discussed in Chapter Four. Only further research can reveal the full range of phenomena that are to be accounted for by means of surface structure constraints.

One should also ask the question of why languages should have a surface structure constraint like (7). The attempt to answer this question should lead us to inquire about why languages have surface structure constraints at all. It has been a defect of the theory of transformational grammar that in order to account for certain empirical facts it must allow transformations to perform a number of operations that make transformations an exceedingly powerful device. Transformations have so much power to add, delete, move, and permute constituents that they are powerful enough to distort deep structures far more than they actually do. Given transformations which have this kind of power, it is a very surprising fact that surface structures do not differ from deep structures more than they actually do. This fact has been unexplained in the theory of transformational grammar. The existence of the surface structure constraint (7) may be able to give us some insight into this matter. It may well be that the output of the transformational component of the grammars of natural languages is subject to certain surface structure constraints which reject as ungrammatical any surface structure that does not 'look like' deep structures in certain respects. If this is so, transformations may in fact produce all kinds of highly distorted surface structures which do not resemble deep structures at all, but these structures are discarded by surface structure constraints and therefore do not qualify as grammatical sentences. Only those surface structures which resemble deep structures in the relevant respects would emerge as grammatical sentences. If this is correct, it remains to discover and to define precisely what the 'relevant respects'

are. The surface structure constraint (7) would then be a special case of a much more general phenomenon. Whereas Type B languages do not care whether each S has a subject in surface structure, Type A languages do and discard as ungrammatical any sentence in which this is not so. It would therefore not be surprising to discover that there are other surface structure constraints in the grammars of some languages but not others, which require that surface structures resemble deep structures in some other way. If this is the case, such surface structure constraints may be able to explain why surface structures do not differ from deep structures more than they actually do.

Footnotes to Chapter Five

1. The precise details of relativization are not relevant here. The important point is that the noun phrase in the relative clause that is identical to the antecedent is taken out of its position in the relative clause and is moved to the front of the relative clause, where it ends up as a relative pronoun - qui or que.
2. I expect this to be the case if it is possible to question or relativize noun phrases in subordinate clauses in the first place. In Russian, for example, it is impossible to question or relativize — anything at all in subordinate clauses of the type under discussion, so we cannot expect the subjects of such subordinate clauses to be questionable or relativizable.
3. The question of whether dummy subjects like French il are present in deep structure or introduced by transformations is not directly relevant to our hypothesis. This matter is discussed briefly in what follows.
4. By 'Pro' we do not mean any pronoun, but rather the entity which is the underlying subject of the Spanish sentences with 'impersonal se' discussed in Chapter Four, and which is spelled out as on in French and man in German.
5. If they allow anything to be moved out of subordinate clauses, as we noted in footnote 2.
6. The conditions under which subject pronouns can be deleted vary within certain limits in different languages, but that is not of

concern to us here. We are speaking here of languages in which subject pronouns can be deleted, regardless of the conditions under which this takes place.

7. I am indebted to Wayles Brown for this information on Serbo-Croatian, Michael Brame on Arabic, John Ritter on Hausa, Kenneth Hale on Walbiri, and Rudolph De Rijk on Basque.
8. A theory of tree-pruning is proposed and discussed by Ross (1967), Chapter Three. The entire issue of pruning is discussed in greater detail in what follows.
9. I have also pruned away the NP-node that dominates the circled S-node in (60), as seems correct. However, I know of no general principle which predicts that this NP-node must be pruned.
10. The fact that Extrapolation has applied in (63) is not evidence that there is an S-node above the electorate is gullible in surface structure. This is because that can not be deleted when the sentence has not been extraposed. Thus we have That Claude came late annoyed me, but not *Claude came late annoyed me. This means that that-deletion does not occur until after Extrapolation has applied. If that-deletion causes pruning of the dominating S-node, then, this will not occur until after Extrapolation has applied. The fact that Extrapolation has applied therefore tells us nothing about whether we have an embedded S-node in surface structure.

Reflexivization also fails to provide us with evidence as to where pruning takes place. Ross (1967) proposes that Equi-NP Deletion causes pruning of the embedded S-node in sentences like Dan

forced Carol to photograph him. If this is correct, pruning of the embedded S-node must take place after Reflexivization has applied for the last time, in order to prevent the ungrammatical *Dan forced Carol to photograph himself. Similarly, the fact that we get Dan thinks Carol photographed him rather than *Dan thinks Carol photographed himself fails to provide us with any evidence as to whether the embedded clause in such sentences is dominated by an S-node in surface structure, since pruning could occur after Reflexivization has applied for the last time, as in the sentences with force above.

11. In this connection, it is interesting to note that for some speakers of French, examples like la speakerine qu'il a dit qui s'est évanouie and Qui a-t-il dit qui s'est évanoui? are grammatical. It is a mystery how the relative pronoun qui gets into the position after dit in these sentences, but given that it is there, it follows from what has been said that these examples will not be rejected by the constraint (7) and will therefore qualify as grammatical sentences.
12. In Smith's analysis, there are rules both to delete the relative pronoun and to delete the verb be as well, whereby relative clauses containing be and an adjective are reduced to just an adjective. The latter phenomena, involving deletion of be, do not concern us here; only the deletion of the relative pronoun is relevant to the present discussion.
13. As Morris Halle has pointed out to me, we observe the same phenomenon in cleft sentences.
 - (i) a. ~~It's Zbigniew that Marie loves.~~

b. It's Zbigniew Marie loves.

(ii) a. It's Zbigniew that loves Marie.

b. *It's Zbigniew loves Marie .

Noam Chomsky points out that factors other than the presence of a subject must be involved in the phenomenon of Relative Reduction because of examples like

(iii) a. the man who at last John succeeded in meeting

b. *the man at last John succeeded in meeting

14. Sentences of this sort are acceptable as telegraphic or headline style, which suggests that in this style the constraint (7) is not operative.
15. In the case of there, there are strong arguments that it is transformationally introduced, as we saw in footnote 2 in Chapter Three. It is also clear that not all instances of expletive it can originate from the phrase structure rule NP---> (Det) N (S) posited by Rosenbaum (1967). Under Rosenbaum's analysis, the it is introduced as the N in the above structure, and shows up when the subject S is extraposed, as in It is obvious that time is short. Rosenbaum's analysis therefore cannot account for cases in which we have expletive it but no extraposed sentence. But there are such cases, for example: It's amazing the number of people who eat American style; It's neat the way that works. These examples suggest that English has a transformation which inserts expletive it into sentences which lack a subject at some late stage of derivations.
16. Note that the appearance of the infinitive in the embedded

sentence in (84) can not be accounted for by means of the Kiparskys' proposal discussed in Chapter One, according to which the infinitive appears when the subject has been removed from an embedded sentence. In (84), as we have taken pains to show, the subject has not been removed, and we still have an infinitive. This is also the case in sentences like (56). If the Kiparskys' proposal is correct for English, then, there must be more than one source of the infinitive.

17. This idea has been suggested by Postal (1968).

EPILOGUE

EPILOGUE

Filtering in Generative Grammar

The problem of filtering in generative grammar arises as a result of the fact that the base component generates structures which underlie no well-formed sentences. Grammars consequently need devices which filter out ill-formed sentences. To include such filtering devices in grammars is essentially to preserve Chomsky's idea that a well-formed sentence is one which passes through the syntactic component without any violations having taken place. In order to preserve this idea in this way, it is necessary to include deep and surface structure constraints as well as transformations in the syntactic component.

Because linguistic theory must allow grammars to make use of deep and surface structure constraints as well as the filtering power of transformations, it makes grammars exceedingly powerful. There is too wide a range of possibilities for dealing with particular cases in natural languages. It is therefore necessary to incorporate into linguistic theory some general principles which will restrict the range of possibilities available to grammars in particular cases.¹

Let us consider first the role of the transformational component in filtering out ill-formed sentences. In most recent work in generative grammar, a principle of the following kind has been implicit, although it has not to my knowledge been explicitly formulated:

(1) The blocking principle:

The transformational component blocks a derivation just in case an obligatory transformation is unable to apply because of a metaconstraint on grammars.

(1) makes it impossible to state conditions on transformations under which they would cause a derivation to block. Without a principle like (1) in linguistic theory, it would be possible to cause a derivation to block in any of a number of ways. For example, in the examples discussed

in Chapter Four in which the pronoun sequence se se arises as a result of the application of the spurious se rule, without a principle like (1) in linguistic theory it would be possible to give a blocking condition like:

- (2) The derivation blocks if the spurious se rule applies to a pronoun sequence which both commands and is commanded by another se.²

Allowing blocking conditions like (2) would make possible many incorrect solutions in particular cases. Most important, there are no cases known where such blocking conditions are needed. In order to exclude blocking conditions like (2), the blocking principle (1) must be included in linguistic theory.

The blocking principle is in fact implicit in most work that has been done within the framework of Chomsky (1965), since in the two cases in the literature where the filtering function of transformations is actually used, this principle is in fact adhered to. In the first set of such cases, discussed in Chomsky (1965), in which there are sentences with relative clauses which do not contain a noun phrase identical to the antecedent, Chomsky proposes that what causes the derivation to block is not a particular condition on the relativization transformation, but rather a metaconstraint on grammars which requires that all deletions be recoverable. In the other case of transformational blocking in the literature, the examples discussed in Ross (1967), an obligatory movement transformation can not apply because the constituent that must be moved is in a structure which nothing can move out of due to a universal constraint. As a result, derivations block and sentences are characterized as ungrammatical. Both sets of examples in the literature in which transformations are used as filters, then, conform to the blocking principle (1).

It correctly excludes blocking conditions like (2), according to which the application of a transformation causes a derivation to block, and reserves blocking for cases where the inability of a transformation to apply because of a metaconstraint on grammars causes a derivation to block.

The only attempt that has been made to use the transformational component to block derivations in a particularistic way that does not follow from metaconstraints on grammars was Lakoff's proposal that 'absolute exceptions' be included in linguistic theory. But no evidence has ever been presented to show that they succeed in capturing significant generalizations, and we have seen that the two strongest cases of absolute exceptions - the like-subject and unlike-subject constraints - can simply not be treated as absolute exceptions for reasons of empirical inadequacy. It is significant that this filtering device which violates the blocking principle is empirically inadequate. The fact that this principle rules out the use of absolute exceptions is therefore another reason to include the blocking principle (1) in linguistic theory.

In the course of our discussion in Chapters Four and Five, at several points we found ourselves faced with a choice between handling certain phenomena transformationally or adopting a surface structure constraint. In each case we found evidence to indicate that the surface structure constraint was the correct solution. A stronger theory of language would in many cases dictate the choice of solution. It is our task to build such a theory by providing general principles which dictate the choice of some solutions over others and by showing that the choices dictated by these principles are in fact the correct ones. The correctness of the solutions dictated by these principles is the

empirical evidence that supports the principles.

At the same time, we must redress an imbalance in present linguistic theory. Most syntactic phenomena have been handled transformationally within the framework of generative grammar, since generative grammatical theory provided little in the way of alternative solutions to specific problems.³ The addition of surface structure constraints to linguistic theory makes possible another set of solutions to many problems, and in many cases we will be faced with a choice between a transformational solution and a surface structure constraint. The existence of such choices is closely related to another problem - the fact that transformations are far too powerful and need to be constrained. In what follows we will attempt to take a tentative first step toward suggesting the means by which these two problems can be attacked simultaneously.

The literature on transformational grammar contains a number of transformations whose application is governed by certain conditions.

We see, for example, conditions of the following kinds:

(3) Conditions on transformations:

- (a) An optional transformation is obligatory under certain circumstances.
- (b) An obligatory transformation is optional under certain circumstances.
- (c) There are circumstances under which a given transformation can not apply, even though its structural description is met.

In Chapter Five, we were faced with the question of deciding whether to place a condition of type (3a) on the that-deletion transformation in English. This transformation is optional and relates pairs of sentences like

- (4) a. He thinks that no one will ever find him.
 b. He thinks no one will ever find him.

But we noted that if the subject of a subordinate clause introduced by that is relativized or questioned, we find paradigms like

- (5) a. *Who do you think that robs churches?
 b. Who do you think robs churches?

One transformational solution to the problem would be to order the that-deletion transformation after Relativization and Question Formation, and to make this optional transformation obligatory just in case that is immediately followed by a VP. This would be a condition of type (3a) on the that-deletion transformation. In Chapter Five evidence was produced to show that this solution is inadequate. But it would be preferable if linguistic theory ruled solutions like this one out of consideration without at the same time excluding correct solutions.

We will here tentatively propose that the following principle be incorporated in linguistic theory,

(6) The condition principle:

When faced with a choice between two adequate solutions, one of which imposes conditions of type (3) on transformations and the other of which does not, the solution that does not impose such conditions on transformations is correct.

This principle correctly leads us to choose a surface structure constraint over a transformational solution to the problem posed by the data of (5). It also dictates the choice of the correct solution in the case of the Spanish object pronouns discussed in Chapter Four. In Spanish we had the option of imposing a number of conditions of type (3c) on transformations. The constraint (28) of Chapter Four, which stated that the weak form of an indirect object pronoun may not be used if the

indirect object is second person singular and the direct object is first person is a transformational constraint of type (3c). In our discussion of the various ways that the clitic sequence se se could arise in Spanish and the various rules that could be constrained in order to prevent such se se sequences from arising, we considered constraining Pronominalization, Dislocation, Indirect Object Doubling, the spellout of an underlying Pro subject as impersonal se, and the spurious se rule in order to prevent se se sequences from arising. All of these transformational constraints we considered are conditions on transformations of type (3c). With the condition principle (6) in linguistic theory, we would not have to find evidence against these alternatives, for the condition principle would correctly force us to adopt a surface structure constraint in preference to placing conditions of type (3) on transformations.

The condition principle is to be interpreted as part of the evaluation measure for syntax.⁴ In the cases we have considered, it would lead us to adopt the correct solutions. At the same time, it reduces the power of transformations. It remains to see whether it also leads to the choice of correct solutions in other cases that we have not considered here. It is on these grounds that its inclusion in linguistic theory must rest. The evidence presented here for the condition principle is not sufficient for its adoption. Since progress in linguistics depends on extracting as much as possible from the grammars of particular languages and formulating general principles from which the facts of particular languages will follow as automatic consequences, it is only by proposing such general principles and testing them against linguistic data that the field can advance.

Conditions of type (3) do not exhaust the range of conditions that it is possible to place on transformations. Specifying the range of such conditions is made difficult by the inexplicitness of the notion 'condition' itself. The key phrase in the conditions given in (3) would appear to be 'under certain circumstances.' The intuitive notion of 'condition on a transformation' seems to involve a statement to the effect that whereas in the general case a transformation does one thing, 'under certain circumstances' it does something else. (3) involves cases where the applicability, obligatoriness, or optionality of a transformation is variable, depending on 'certain circumstances.' The notion of 'condition on a transformation' should also include cases where the change which a transformation effects in phrase markers is variable, depending on 'certain circumstances.' If conditions on transformations of this sort are allowed by linguistic theory, then a number of incorrect solutions become possible. Consider, for example, the kinds of facts that are captured by the ordering of transformations. The reflexivization transformation is said to precede the transformation which deletes the underlying second person subject of imperatives in order to account for the reflexive pronoun in sentences like

(7) Kick yourself.

Reflexivization applies when the underlying you subject is still present, accounting for the reflexive pronoun yourself. But as Robert Wall has pointed out, we could let the rules apply in the opposite order and still account for sentences like (7) by complicating the reflexivization transformation. The reflexivization transformation would reflexivize any noun phrase that is identical to a preceding noun phrase in the same simplex sentence, and it would also reflexivize second person noun phrases, and

second person noun phrases only, if the sentence has no subject. To do this is essentially to place a condition on the reflexivization transformation that under 'certain circumstances' - namely, if the sentence has no subject - it acts differently than it does in the general case. As Wall pointed out, facts accounted for by the ordering of transformations can also be stated in this way. Since this device fails to capture significant generalizations, it is necessary for linguistic theory to exclude such incorrect solutions in principle.

One way to do this would be to extend the condition principle (6) to include these cases. Assuming that it is possible to specify what is meant by the notion 'condition on a transformation' along the lines that have been suggested here, we can restate the condition principle as follows:

(8) The condition principle:

When faced with a choice between two adequate solutions, one of which imposes conditions on transformations and the other of which does not, the solution that does not impose such conditions on transformations is correct.

In addition to handling the cases dealt with by (6), the condition principle (8) also forces us to order the reflexivization transformation before the imperative transformation rather than place a condition on the reflexivization rule.

It is quite likely, however, that the condition principle (8) is still not strong enough. The condition on the reflexivization transformation mentioned above, as well as other such devices, should probably be excluded in principle. We can therefore formulate an even stronger principle

(9) The no-condition principle:

In the grammars of natural languages there are no conditions on transformations.

Assuming a specification of the notion 'condition on a transformation' along the lines suggested above, the no-condition principle (9) would rule out conditions of type (3) as well as conditions like the one on the reflexivization transformation and thereby make the condition principle (8) unnecessary. Since the literature on generative grammar contains many examples of conditions of type (3), if the analyses on which they are based are correct, the no-condition principle (9) is false. If the no-condition principle is correct, on the other hand, much in past theory and practice is incorrect. For this reason, the no-condition principle (9) is rather speculative at this time. It is worth mentioning, however, because it may well be correct. If it is, it would constrain the power of grammars to a considerable extent. But to the extent that it would constrain grammars and thereby enrich linguistic theory, it stands in need of empirical support.

There is, incidentally, a non-trivial problem concerning the formulation of any principles such as (6), (8), or (9). In order to formulate any such principles, we must be able to distinguish conditions on transformations from the structural descriptions of transformations. Even if the structural descriptions of transformations are restricted to Boolean conditions on analyzability, as proposed in Chomsky (1965), the existence of syntactic features in linguistic theory and the fact that the structural descriptions of transformations can refer to syntactic features makes it difficult to define the notion 'conditions on transformations' in a way that will prevent such conditions from being smuggled into transformations through their structural descriptions, without

at the same time constraining structural descriptions in too severe a way. This situation arises as a result of the fact that syntactic features, as Chomsky (1969) has pointed out, are an extremely powerful device. If the inventory of syntactic features that can be used in grammars is not sufficiently constrained, what are essentially conditions on transformations could be stated in the form of syntactic features which the structural descriptions of transformations could refer to. The solution to this problem obviously lies in constraining the inventory of available syntactic features in an appropriate way. If we assume that this can be done, and if the notion 'condition on a transformation' can be made precise, the scope of the condition principle (8) and the no-condition principle (9) is clear, and these principles can be tested empirically. If either of these principles proves to be correct, it will not only exclude incorrect solutions like the one which would order the imperative transformation before the reflexivization transformation, but by reducing or eliminating the role of conditions on transformations, it would have the effect of reducing the load of transformations in grammars. In this connection it is worth noting that if the no-condition principle is correct it would redress an imbalance in current theory. The blocking principle (1), which has in practice been followed in most recent work, prevents conditions on transformations from playing any role in the filtering function of transformations. The no-condition principle would prevent conditions on transformations from playing a role in the other functions of transformations as well.

Returning now to the problem of developing general principles which will automatically rule out incorrect solutions, we observe that the ordering of transformations can be used to 'account for' certain

correlations without explaining them. This is to some extent linked with the practice of placing conditions on transformations. For example, in the case of paradigms like (5) in English, we note that there is a correlation between the deletion of that and the ability to move the subject of a subordinate clause out of that clause. The question before us is how this correlation is to be accounted for. We could attempt to solve the problem transformationally by placing a condition on Relativization and Question Formation to the effect that they can not apply to the subject of a subordinate clause if that has not been deleted. This solution requires us to order Relativization and Question Formation after that-deletion. Another way to handle paradigms like (5) transformationally would be to make that-deletion obligatory in cases where the subject of the subordinate clause has been relativized or questioned. This solution requires us to order Relativization and Question Formation before that-deletion. Each of these transformational solutions, then, requires a particular order between the that-deletion transformation on the one hand and the Relativization and Question Formation transformations on the other. With a surface structure constraint, however, as we saw in Chapter Five, that-deletion is not crucially ordered with respect to Relativization and Question Formation.

It is true that the condition principle (8) would lead us to reject these transformational solutions in favor of a surface structure constraint. But it still seems reasonably likely that some other principle is needed to rule out the kind of excessive use of the ordering of transformations which must be resorted to by the transformational solutions to the problem of (5) that are sketched above. On the other hand, it is clear that there are many cases for which ordering of transformations

captures significant generalizations. In the case of the reflexivization and imperative transformations, for example, ordering reflexivization before the imperative rule embodies the claim that it is not accidental that the only reflexive pronouns that we find as the object of simple imperatives like (7) are second person. It is necessary to rule out the kind of excessive use of ordering that we see in the transformational solutions to the problem of (5) that we sketched above, while at the same time permitting ordering of transformations in those cases in which it succeeds in capturing valid generalizations. In order to do this we will attempt to develop a notion of ordering strain. The amount of ordering strain in a given proposed solution is defined as the number of pairs of transformations that are crucially ordered.⁵ We can then state a general principle as follows:

(10) The ordering strain principle:

When we are faced with a choice between two adequate solutions, the one with less ordering strain is correct.

The ordering strain principle, like the condition principle (8), is a candidate for inclusion in the evaluation measure for grammars. In the case we have been considering, that of accounting for paradigms like (5) in English, it correctly leads us to reject the two transformational solutions sketched above, which merely 'account for' the observed correlation, in favor of a surface structure constraint, which explains it. Note that the ordering strain principle could not even be seriously considered if we did not already have a principle which rules out the use of conditions on transformations, since without such a principle the ordering strain principle would incorrectly lead us to choose a solution in which we place a condition on the reflexivization transformation over one which orders reflexivization before the imperative rule. This

suggests that it may not be possible to discover universal principles individually, since they may be crucially interdependent.

The ordering strain principle (10) also serves to prevent us from picking the wrong solution to deal with Spanish sentences like

(11) Se les da los honores a los generales.

'Pro gives the honors to the generals,' i.e., 'The honors are given to the generals.'

discussed in Chapter Four. We must prevent los honores from undergoing Pronominalization to los, for that would produce

(12) *Se les los da a los generales.

which is ungrammatical, and the application of the spurious se rule would convert it to

(13) *Se se los da a los generales.

which is also ungrammatical. One transformational solution would be to somehow prevent Pronominalization from applying to (11). It is then necessary to prevent Dislocation from applying as well, for with Dislocation, pronominalization of the dislocated noun phrase is obligatory, and that would result in ungrammatical sentences.

(14) a. *Los honores se les los da a los generales.

b. *Los honores se se los da a los generales.

A transformational solution here would have to prevent Dislocation and Pronominalization from applying to sentences like (11) - that is, to sentences which already contain a se and a third person indirect object clitic pronoun. Under this solution, then, Dislocation and Pronominalization must be ordered after the rule which spells out an underlying Pro subject as impersonal se.

and after the rule which doubles the indirect object (a los generales) as a pronoun (les). With a surface structure constraint,

as was proposed in Chapter Four, Dislocation and Pronominalization are not crucially ordered with respect to these two transformations. The transformational solution, then, evinces greater ordering strain. The ordering strain principle (10) tells us to adopt a surface structure constraint on the order of clitic pronouns rather than the transformational solution. As we have seen in Chapter Four, this is the correct solution. The fact that it is supports the ordering strain principle.

The evidence given here is not sufficient to demonstrate that the ordering strain principle (10) is part of linguistic theory, but it is at least highly suggestive. More important, I do not know of any cases where the ordering strain principle would cause us to adopt an incorrect solution.

As was remarked above, the condition principle (8) and the ordering strain principle (10) are to some extent interdependent. This is so because in many cases we are trying to handle transformationally a correlation which is to be explained in some other way. As in the case of the correlation between that-deletion and the ability to move the subject out of a subordinate clause in English, if we attempt to account for the correlation transformationally we must place a condition on one rule which makes it work differently, depending on whether or not another rule has already applied. For this reason, the rule which we place the condition on must necessarily follow the other one. The attempt to account for such correlations transformationally therefore necessarily leads to greater ordering strain. For this reason, the ordering strain principle succeeds in ruling out solutions under which ordering of transformations can be used to 'account for' certain correlations without explaining them. The surface structure constraints

proposed in Chapters Four and Five succeed in explaining the correlations which the ordering of transformations does not.

Since the condition principle (8) and the ordering strain principle (10) are to some extent interdependent, in order to establish each of them it would of course be necessary to show cases where each is necessary and the incorrect solution would not be ruled out by the other. Since my aim here is suggestive rather than definitive, I will not do that here. The ordering strain principle, in particular, stands in need of empirical support. It is important to note, however, that if either or both of these principles is correct, the power of the transformational component is to that extent constrained and linguistic theory is correspondingly enriched.

The power of linguistic theory is the greater, the more it constrains the grammars of natural languages. Conversely, the more powerful the grammars that the theory allows are, the less strong is the theory that allows them. Within this context, let us consider the implications of the inclusion of surface structure constraints in linguistic theory for the power of individual grammars and therefore for the strength of linguistic theory itself. Let us contrast two linguistic theories.

Theory A: Sentences have a deep structure which is semantically interpreted and contains information about grammatical relations. Transformations map deep structures onto surface structures. Surface structures are what result automatically from the application of transformations to deep structures. There is consequently no independent theory of surface structure.

Theory B: Sentences have a deep structure which is semantically interpreted and contains information about grammatical relations. Transformations map deep structures onto surface structures. There are also constraints on surface structures which well-formed sentences must satisfy.⁶

It is clear that Theory B puts a wider range of grammatical devices at the disposal of individual grammars, for it allows them to use surface

structure constraints in addition to the other devices available to grammars, while Theory A does not. For this reason, the addition of surface structure constraints to linguistic theory, by itself, allows grammars to be more powerful than they were under the theory without surface structure constraints. As a result, if we do not use the availability of surface structure constraints to restrict the power of grammars in other ways, a linguistic theory with surface structure constraints is weaker than one without them.

The task before us, then, is to use the availability of surface structure constraints to constrain the power of grammars in other ways. This is what we have been attempting to do in formulating the condition principle (8), the no-condition principle (9), and the ordering strain principle (10). These principles would be totally impossible in a linguistic theory without surface structure constraints, since their effect is to constrain the power of the transformational component by putting some additional load on surface structure constraints. If we can discover the range of phenomena that are to be handled by means of surface structure constraints and place appropriate constraints on the notion 'surface structure constraint' itself, then we will have succeeded in placing considerable constraints on the notion 'human language.'

But the significance of principles like the condition principle and the ordering strain principle goes beyond the fact that they shift a certain amount of the work load of grammars from the transformational component to surface structure constraints. Their true importance, if they are correct, lies in the fact that they contribute to the development of an evaluation measure which will enable us to choose between competing grammars. Without the availability of surface structure

constraints, this step toward the development of this indispensable part of a substantive theory of language could not be taken.

We have seen, then, that although it appears at first that the addition of surface structure constraints to linguistic theory results in more powerful grammars and therefore a weaker theory, the availability of surface structure constraints can be used toward the development of universal principles which constrain grammars and enrich linguistic theory to a considerable extent. Another possibility also appears promising. Since most syntactic phenomena have been handled transformationally in generative grammar, it has been generally assumed that the way to constrain grammars is to constrain the power of transformations. But it has proved exceedingly difficult to do this and still account for the linguistic data. The addition of surface structure constraints to linguistic theory makes it possible to constrain grammars in another way. It is entirely conceivable that transformations are exceedingly powerful devices, but that the output of transformations is subject to surface structure constraints which drastically reduce the number of sentences that qualify as grammatical. As was observed in Chapter Five, transformations have the power to distort deep structures far more than they actually do in converting them to surface structures. We speculated that the reason that Type A languages have the surface structure constraint (7) of Chapter Five in their grammars might be connected with some requirement that surface structures resemble deep structures in certain respects; while Type B languages would require that surface structures resemble deep structures in some respects, Type A languages also require that sentences contain a subject in surface structure. If anything along these lines is correct, it is quite

possible that transformations actually do produce a much larger variety of surface structures than are grammatical, and it falls to surface structure constraints to actually constrain the output of grammars, keeping it within the more narrow limits that we find in language. If this is the case, this is another way that surface structure constraints serve to constrain grammars and thereby enrich linguistic theory.

It has been the aim of this Epilogue to point out that the availability of three different kinds of filtering devices in grammars makes possible too wide a range of solutions in particular cases and thereby makes grammars much too powerful. It is therefore necessary to develop universal principles which dictate the choice of solution in particular cases. We have attempted to formulate several such principles in order to show that the availability of several different kinds of filtering makes it possible to develop universal principles which would have been unformulable without them. The particular principles proposed here will most likely turn out to be incorrect. But if their formulation here serves to focus interest on the problem of developing such universal principles and makes linguists aware that the range of filtering devices available to grammars makes the formulation of such universal principles possible, then this Epilogue will have served its purpose well.

Footnotes to Epilogue

1. We address ourselves here to the problem of the availability of too wide a range of possible solutions caused by the availability of three different kinds of filtering in linguistic theory. An analogous situation, the availability of too wide a range of possible solutions due to the fact that both transformations and syntactic features are very powerful devices, is discussed by Chomsky (1969). Chomsky there attempts to develop general principles which will decide between the use of transformations and the use of syntactic features in particular cases. While Chomsky's proposals and the suggestions sketched here are totally independent of each other, they both have the effect of reducing the role of transformations in grammars.
2. As Ross (1967) has shown, the notion 'both commands and is commanded by' characterizes the notion 'in the same simplex sentence as.'
3. The introduction of syntactic features into linguistic theory in Chomsky (1965) makes possible non-transformational solutions of another kind. For discussion of the problem of choosing between transformational and feature solutions, see Chomsky (1969). This problem will not concern us here.
4. For discussion of evaluation measures in linguistic theory, see Halle (1961), Chomsky and Halle (1965), and Chomsky and Halle (1968).

5. Further problems arise in the attempt to make this definition reflect what is intuitively meant by the term 'strain.' For example, if Rule A must precede Rule B, and Rule B must precede Rule C, we have two crucially ordered pairs of rules, hence an ordering strain of two. Now, if there is also evidence that Rule A must precede Rule C, this should not increase the ordering strain to three. Some way would have to be found to incorporate such intuitively correct modifications of our simplistic definition into the definition of 'ordering strain.'

6. Chomsky (1955) raised the question of whether surface structure phrase structure rules are needed independently of the phrase structure rules of the base and concluded that they are not, since derived structure can be determined solely by base rules and rules of derived constituent structure. In other words, he considered both of these theories and, on the basis of the evidence then available, concluded that Theory A is correct. Although the precise nature of surface structure constraints remains an open question, we have attempted to show in Chapters Four and Five that Theory B is in fact correct.

BIBLIOGRAPHY

- Anderson, S.
 (1968) "Pro-sentential forms and their implications for sentence structure," in Report No. NSF-20 (The Computation Laboratory of Harvard University).
- Bierwisch, M. and K. Heidolph
 (1968) Recent Developments in Linguistics (The Hague: Mouton and Co.).
- Browne, W., K. Hale, and D. Perlmutter
 (in preparation) "Clitic placement in universal grammar."
- Chomsky, N.
 (1955) The Logical Structure of Linguistic Theory (Microfilm, the M.I.T. Library).
 (1957) Syntactic Structures (The Hague: Mouton and Co.).
 (1965) Aspects of the Theory of Syntax (Cambridge: The M.I.T. Press).
 (1969) "Remarks on nominalization," in Jacobs and Rosenbaum (1969).
- Chomsky, N. and M. Halle
 (1965) "Some Controversial Questions in Phonological Theory," Journal of Linguistics, 1.97-133.
 (1968) The Sound Pattern of English (New York: Harper and Row).
- Dougherty, R.
 (1968) A Transformational Grammar of Coordinate Cojoined Structures (Unpublished doctoral dissertation, M.I.T.).
- Garcia, E.
 (1967) "Auxiliaries and the criterion of simplicity," Language 43.853-70.
- Gili y Gaya, S.
 (1961) Curso Superior de Sintaxis Española⁸ (Barcelona: Publicaciones y Ediciones Spes).
- Halle, M.
 (1961) "On the role of simplicity in linguistic descriptions," in R. Jakobson (Ed.), Proceedings of the Twelfth Symposium on Applied Mathematics (Providence: American Mathematical Society).
- Heger, K.
 (1966) "La Conjugaison objective en français et en espagnol," Langages 3.19-39.

- Hofmann, T. R.
 (1966) "Past tense replacement and the modal system," in Report No. NSF-17 (The Computation Laboratory of Harvard University).
- Jacobs, R. and P. Rosenbaum
 (1969) Readings in English Transformational Grammar (New York: Sinn and Co.).
- Katz, J. and P. Postal
 (1964) An Integrated Theory of Linguistic Descriptions (Cambridge: The M.I.T. Press).
- Kiparsky, P. and C. Kiparsky
 (1968) "Fact," in Bierwisch and Heidolph (1968).
- Kraak, A.
 (1967) "A search for missing agents" (Unpublished paper, M.I.T.).
- Lakoff, G.
 (1965) On the Nature of Syntactic Irregularity (Report No. NSF-16, The Computation Laboratory of Harvard University).
 (1966) "Deep and Surface Grammar" (unpublished manuscript, Harvard University).
 (in press) "Stative verbs and adjectives in English," in T. Bever and W. Weksel (Eds.), Readings in Psycholinguistics.
- Lakoff, G. and S. Peters
 (1969) "Phrasal conjunction and symmetric predicates," in Reibel and Schane (1969).
- Lakoff, G. and J. Ross
 (1966) "A Criterion for verb-phrase constituency," in Report No. NSF-17 (The Computation Laboratory of Harvard University).
 (in preparation) The Transformational Component.
- Lees, R.
 (1960) The Grammar of English Nominalizations (Publications of the Indiana University Research Center in Anthropology, Folklore, and Linguistics).
- Lees, R. and E. Klima
 (1963) "Rules for English Pronominalization," Language 39.17-28.
- Postal, P.
 (1967) "Linguistic Anarchy Notes: Horrors of Identity" (Unpublished communication).
 (1968) "The method of universal grammar," in P. Garvin (Ed.), Proceedings of the 1966 Conference on Linguistic Method.

- Real Academia Española
 (1931) Gramática de la Lengua Española (Madrid: Espasa-Calpe).
- Reibel, D. and S. Schane
 (1969) Modern Studies in English (Englewood Cliffs: Prentice-Hall).
- Rosenbaum, P.
 (1967) The Grammar of English Predicate Complement Constructions (Cambridge: The M.I.T. Press).
- Ross, J.
 (1967a) "Auxiliaries as verbs" (Unpublished ditto, M.I.T.).
 (1967b) Constraints on Variables in Syntax (Unpublished doctoral dissertation, M.I.T.).
- Smith, C.
 (1961) "A class of complex modifiers in English," Language 37.342-65.
 (1964) "Determiners and relative clauses in a generative grammar of English," Language, 40.37-52.
- Stockwell, R., J. D. Bowen, and J. Martin
 (1965) The Grammatical Structures of English and Spanish (Chicago: The University of Chicago Press).
- Vetter, D.
 (1967) Need (Unpublished honors thesis, Dept. of Humanities, M.I.T.).
- Warszawsky Harris, F.
 (1965a) "Reflexivization I" (Unpublished paper, M.I.T.).
 (1965b) "Reflexivization II" (Unpublished paper, M.I.T.).

Biographical Note

The author was born in New York, New York on October 28, 1938. He attended the public schools in Salt Lake City (Utah), Philadelphia (Pennsylvania), Anniston (Alabama), Arlington (Virginia), and Chicago, Chicago Heights, and Park Forest (Illinois), and the American Community School of Paris (France). He was graduated from Rich Township High School in Park Forest, Illinois in June 1955. He attended Harvard College, where he majored in Social Relations and was graduated Magna Cum Laude in June 1959, and was elected to Phi Beta Kappa.

The author enrolled in the Graduate School of Arts and Sciences of Harvard University, where he studied Sociology and Far Eastern Languages during the academic year 1959-1960 and Economics in 1961-62. He enrolled at M.I.T. as a graduate student in Linguistics in September 1964. He studied at M.I.T. through September 1967, when he withdrew, and was subsequently readmitted for the summer term in 1968.

He was an instructor in the Department of Modern Languages at M.I.T. from September 1960 to June 1965. He was a research associate with the Committee on Programmed Instruction of Harvard University from September 1962 to June 1965. Since September 1967 he has been an assistant professor in the Department of English at Brandeis University.

Two papers by the author will appear in the near future. "On the Article in English" will appear in M. Bierwisch and K. Heidolph (Eds.), Recent Developments in Linguistics (The Hague: Mouton and Co., 1968), and "The Two Verbs 'Begin'" in P. Rosenbaum and R. Jacobs (Eds.), Readings in English Transformational Grammar (New York: Ginn and Co., 1969).

