

ORGANISED BY THE  
COMMISSION OF THE  
EUROPEAN  
COMMUNITIES

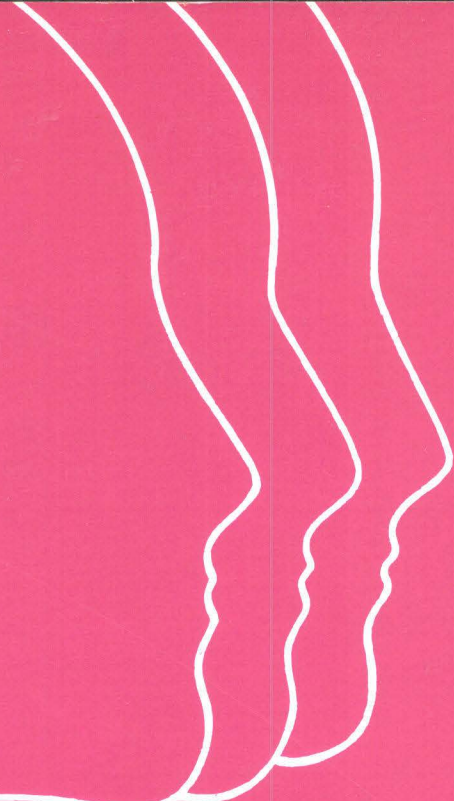

# **Videotex in Europe Conference Proceedings**

**Edited by  
Carlo Vernimbo and William Skyvington  
With a preface by  
Georges Anderla**



**Learned Information  
Oxford and New York**





---

# Videotex in Europe

---





6. 8/1/79  
1. 4. 1. 2.

5  
5

Proceedings of the  
**Videotex in Europe**  
Conference  
Luxembourg 19–20 July 1979

Organised by the  
COMMISSION OF THE  
EUROPEAN  
COMMUNITIES

Edited by  
Çarlo Vernimb and William Skyvington  
With a preface by  
Georges Anderla



[ Learned Information 1980 Oxford and New York

5/11/79

2.1.

2.1. 2.11/79

Videotex in Europe

© ECSC, EEC, EAEC, Brussels and Luxembourg, 1980

All rights reserved

ISBN 0 904933 22 9

**Published by**

Learned Information (Europe) Ltd.  
Besselsleigh Road  
Abingdon  
Oxford OX13 6EF  
England

Learned Information  
The Anderson House  
Stokes Road  
Medford, N.J. 08055  
U.S.A.

(609) - 654-6366  
\$50.00

# Contents

	<i>Page</i>
<b>PREFACE</b>	
Mr. G. Anderla, Director — Information Management (CEC Directorate General XIII)	vii
<b>EDITORS' NOTE</b>	ix
<b>OPENING OF THE CONFERENCE</b>	
Mr. R.K. Appleyard, Director General — Scientific and Technical Information and Information Management (CEC Directorate General XIII)	1
<b>INTRODUCTION TO THE STUDIES</b>	
Mr. C. Vernimb, Co-ordinator — New Information Technologies (CEC Directorate General XIII)	3
<b>TERMINOLOGY</b>	5
<b>LECTURE: "Videotex Development in the Community"</b>	
Mr. M. Kohn, (Télésystèmes, Paris)	7
<b>TEXT: "Videotex/Euronet Compatibility"</b>	
[summarized extracts from the study report] (Télésystèmes, Paris)	22
<b>LECTURE: "Videotex Development outside the Community"</b>	
Mr. R. Woolfe (Butler, Cox & Partners, London)	44
<b>DISCUSSION — Session No. 1</b>	51
<b>LECTURE: "Videotex Market in the Community"</b>	
Mr. H.D. Scholz (Pactel, Frankfurt)	63
<b>TEXT: "Videotex Market and Display Study"</b>	
[summarized extracts from the study report] (PA Management Consultants, Frankfurt)	75
<b>LECTURE: "Market for Videotex Business Terminals"</b>	
Mr. R. Barnes (MWS Services, London)	89
<b>LECTURE: "Standards for Text Communication"</b>	
Mr. H. McGregor Ross (Data Systems Consultants, London)	105
<b>TEXT: "Character Sets for Communication of Text"</b>	
[summarized extracts from the study report] (Data Systems Consultants, London)	111

<b>LECTURE: "Technological Environment"</b> Mr. M. Roetter (A.D. Little, Paris)	126
<b>TEXT: "Videotex — Competitive and Complementary Technologies"</b> [summarized extracts from the study report] (A.D. Little, Paris)	135
<b>LECTURE: "Videotex Display and Information Access"</b> Mr. I. McLaren (PA Design Unit, London)	178
<b>DISCUSSION — Session No. 2</b>	188
<b>SECOND DAY OF THE CONFERENCE</b> Mr. G. Anderla, Director — Information Management (CEC Directorate General XIII)	201
<b>RECAPITULATION</b> Mr. T. Sommerlatte (A.D. Little, Wiesbaden)	204
<b>FRAMEWORK FOR FUTURE DISCUSSION</b> Mr. K.M. Simpson (PA International, London)	206
<b>DISCUSSION — Session No. 3</b>	208
<b>CONFERENCE CONCLUSIONS</b> Mr. G. Anderla	235
<b>LIST OF PARTICIPANTS</b>	239

## PREFACE

*Mr. G. Anderla, Director, Information Management, CEC Directorate General XIII*

On the 13th February 1980, in Strasbourg, Europe launched her data-transmission network called Euronet Diane. And Madame Simone Veil, President of the European Parliament, described this first Community effort in the telematics domain as a major step towards the creation of a "Common Market of Information".

The existence of the present book proves that the Commission of the European Communities is interested in the related field of domestic telematics referred to as videotex... which is in fact a European-invented technology.

The proceedings of the Luxembourg conference on videotex, last summer, are presented here in a most readable form. I should simply like to add a few words concerning the circumstances in which the Commission might be prepared to become involved, concretely, in videotex development. In pragmatic terms, the Commission would be interested in examining the possibilities of collaborating in telematics pilot projects that satisfy the following eight criteria:

- 1 - Pilot projects should be directed towards selective applications of new technologies which meet the requirements of new groups of users in the fields of scientific, technical, economic and social information. Alternatively, pilot projects might aim at supplying new higher-quality services to existing user groups.
2. They should show a positive cost/efficiency balance as regards specific market segments.
3. They should relate to a Community-wide field of application beyond the scope of any single nation.
4. They should involve a contractual agreement between the nine PTT administrations, and ensure the gradual adoption (as and when they arise) of standards... which will in turn constitute a strong factor in the promotion of European industry, permitting the creation of a tangible market.
5. They should facilitate the blending of two or more technologies of European origin, and preferably combine at least a new telematics technology with an advanced information processing technology.



6. They should be sufficiently small-scale to be undertaken with limited resources (budget, staff), whilst being so important as to serve as a model for promoters of larger-scale self-financing projects.
7. They should, at the outset, involve only a few partners, so that they can come to voluntary agreements... but they should nevertheless involve a sufficiently broad cross-section of the parties concerned.
8. They should fit into a completion schedule of two to five years' duration, compatible with the budget of the third Action Plan.

I am convinced that this book will be a rich source of ideas and inspiration for everybody in Europe concerned with telematics in general, and videotex in particular.

## EDITORS' NOTE

Several different kinds of source material have been juxtaposed in this book, which is primarily a transcription of practically everything that was said at the two-day conference on the subject of videotex organized in Luxembourg on 19-20 June 1979 by the Commission of the European Communities.

Certain sections of these proceedings are labeled LECTURE or TEXT... and we would like to explain to the reader the sense of these headings. Many months before the scheduled date of the conference, the Commission asked a number of consulting firms to carry out studies on various specific aspects of videotex. This meant that the Commission was able to offer each of the seventy or so participants at the conference an impressive pile of printed documents weighing several kilogrammes: namely, the six study reports produced by these firms. Members of the consulting firms came to the Luxembourg conference in order to present their reports, and each of their verbal presentations has been included in our book under the heading of LECTURE. As far as the printed study reports themselves are concerned, it was out of the question to reproduce their entire contents in the present book, so we have adopted the solution of extracts and summaries, each of which appears here under the heading of TEXT, straight after the corresponding LECTURE.

As editors of these proceedings, our intention has been to reproduce as faithfully and completely as possible the essential aspects of this important encounter between European experts and authorities concerned by videotex. We hope that possible distortions due to language translation, tape recording and summarization are not excessive.

We might add that the book, of course, can hardly re-create what was perhaps the most interesting encounter of all at the conference: a simultaneous demonstration - for the first time in the world - of four of the most widely known videotex systems, namely, Britain's Viewdata (Prestel), France's Antiope (Télétel), Germany's Bildschirmtext and Canada's Telidon.

Carlo Vernimb and William Skyvington  
Luxembourg, November 1979



## OPENING OF THE CONFERENCE

*Mr. R.K. Appleyard, Director General,  
Scientific and Technical Information and  
Information Management, CEC Directorate  
General XIII*

Ladies and gentlemen, you would perhaps like some explanations of why the EEC is interested in videotex. Well, today, all of us here are increasingly part of one economic entity based on a common market. It's an entity which is poor in energy and raw materials, but rich in brains and inventiveness. Within this economic entity, the specific commodity of information seems certain to play a greater and greater rôle in the coming years and decades. And indeed information is a very fortunate commodity in which to deal, because it's unique - I think - in that its value is increased by trade in it and by its use, whereas for most of the hardware commodities the value diminishes. So we feel, those of us who work in the EEC, that we have a duty to look at the information market and industry of the nine countries, and to look in particular to the openness and transparency of this market which - let's be quite clear about it - also represents an advantage worth gaining for all of you. Indeed, in the long run, it's probably both an economic and a political necessity. So we're concerned with all the problems of trans-border, trans-language, trans-system movement of information, and especially with the practical obstacles to these, as well as with the bigger principles of openness and non-selective access to these big new instruments which must be forged, in the first instance, by the public authorities. And we can by no means divorce an open common market for information from the question of a common market for the technology and the instruments which carry it. Those of us who have had to buy TV sets in Belgium and Luxembourg, and pay the current prices, certainly do not want a repetition of the Pal/Secam affair. The stakes are certainly important. If I was to try to summarize the significance of what we are talking about in one phrase, I would cite what an American contributor said in a conference a couple of weeks ago. The advance towards the information society has been astronomical, he said. In 1969 there were 14,000 terminals; today there are two million, and estimates give ten million in 1989. But there are already 130 million television sets in the US which are potentially part of the interactive information network of the future. That's the quantum jump: the factor of ten, the change of scale, the industrial and employment potential. The EEC - as many of our old friends already know - has, in effect, three forms of action or activity. First, by projects, finance or other forms of active co-operation and intervention. Second, by regulation or by the harmonization and supervision of regulations. And

third, of course, by political persuasion. We are, whether we like it or not, a machine that has to talk with ministers and (let's call them) "other political entities". We do try always - not always with success, perhaps, but we do try - to adopt a severely practical approach to our work, and that goes for our information work. And this led us, as our first venture in the information area, to construct - with the help of our post office friends - a modern cheap data-transmission network for scientific, technical and allied information, known under the name of Euronet. This project will, we trust, open commercial operations in the autumn and, from the beginning, will give the single terminal user access to 80 or 90 data bases strung across the Community in a series of host computers. Our market here is really the innovative industrialist, but the videotex market may well be, to a large part, the domestic one. But it is natural to ask what interaction there may be between the two. Can our network serve your purposes, or your operations help with ours? And this, perhaps, explains some of the studies we have put before you, and their approach. But the videotex future is in your hands, not ours. Do you want each country to go it alone in small protected markets, to be gobbled up later by the external colossi that are waiting in the wings? Do you want or need common principles, norms, interfaces? And do you want them enough to make the necessary hard decisions, and to abide by the give-and-take involved? Can we or should we, together, try to plot an orderly evolution with a minimum of regulatory restraints, neither holding back the leaders, nor frustrating the further developers as they advance and leap-frog each other technically? And allowing an orderly evolution of the scope of the systems, for example, towards increasing interaction and even message transmission? We've tried, in putting before you some basic facts, figures and ideas, to provide a background for looking at these questions together. To fill in this background and to answer the questions will require hard work and perhaps, along the road, hard decisions. But, at least, we now make a start by discussing our common problems in common.



## INTRODUCTION TO THE STUDIES

*Mr. C. Vernimb, Co-ordinator, New  
Information Technologies, CEC Directorate  
General XIII*

As you know, videotex is a pretty complex system, and there are many aspects to that system. One single study couldn't have done justice to all the different aspects. That is why we asked for various studies to be made, and they were co-ordinated by the Directorate-General 3 (Internal Market), responsible for industrial policy, and the Directorate-General 13 (Research, Technical Information and Information Management). The latter is in fact the D-G that has invited you to this conference. Our reason for dealing with such technology is to be found in our involvement with Euronet. That is why the first of the studies that we asked to be done deals with the following question: What links are there between Euronet and videotex? The study was done by Télésystèmes in Paris, and Mr KOHN will report on this after I have spoken. His presentation is really an introduction to the videotex system in the Community as a whole. He is not really going to speak so much about the specific Euronet aspects in detail. I should like to take this opportunity to draw your attention to two things which concern all study reports. First of all, we didn't distribute the reports before the meeting because we don't have sufficient time anyway to discuss all the technical details. What we want to do, today and tomorrow, is to have a much more general discussion. Of course, we are not going to deprive you of the reports, and that's why we have made them available on the tables here. Secondly, the study reports express the opinions of the consultants, and not necessarily the opinion of the Commission itself. The second study, on which Mr WOOLFE will report, was carried out by Butler Cox and Partners, London, in liaison with Link, New York. This was a study which was financed by many clients, so the Commission is unfortunately unable to make this report available to you, at any rate not the original report. I'm sure that Mr WOOLFE will be perfectly prepared to meet applications at a certain price, but as regards today's and tomorrow's meetings, he has made available an extract from this report, which will be distributed to you. The study from Butler Cox and Partners describes the development of videotex technology and similar technologies in the United Kingdom and in the United States. A further volume on the rest of Europe will appear shortly. Mr WOOLFE will supplement what Mr KOHN has said, and talk about videotex systems outside the Community. I should like to take this opportunity of drawing your attention to the terminology used. One of the tasks of the Commission was to co-ordinate the various studies, and part of this was to try

to ensure that terminology was used, if at all possible, in a uniform way. And that is why, after consulting experts, we decided on definitions for the different systems and services. We collected definitions, and these definitions are available in the file for today's meeting. A study financed by many clients meant that we were unable to influence the terminology actually used, so I would like to apologize for the fact that Mr WOOLFE and, later, Mr BARNES will probably use terminology that is slightly different to the general one that we have collected. After these first two presentations, there will be a discussion session. After lunch, Mr LAYTON, of the Directorate-General 3, will chair the meeting. Mr SCHOLZ from Pactel, Frankfurt, will report on the videotex market in the Community. This study, which was implemented in connexion with a more technical study, which will be reported on at the final presentation, is to make an estimate as to the future of videotex, and to see whether videotex is feasible in the economic sense. There are many examples of economic failures which were totally unexpected. After that, Mr BARNES will supplement this by a market study on videotex business terminals carried out by MWS Services in London, financed by several clients, among which we can count the Commission. It's interesting to see how, on several points, they have come to similar conclusions to the Pactel study. And it's equally interesting to see, of course, where there are differences. We think that this is so important, by way of a supplement to the other, that we undertook the additional costs of acquiring copies, for you, of the report by MWS Services. And then Mr McGREGOR ROSS from Data Systems Consultants, London, will introduce his study entitled "Character Sets for the Communication of Text". The title of this study is slightly different from the title of his paper. This study is not restricted to videotex, but also covers other forms of text communication. We already said that videotex should not be seen in total isolation. The technological environment should also be taken into consideration, and that is why we asked the firm Arthur D. Little, from Wiesbaden, to carry out the study entitled "Videotex - Competitive and Complementary Technologies". Mr ROETTER will speak on that. The title of that paper will be "Technological Environment". And then today's presentation will be completed by Mr McLAREN speaking about "Videotex Display and Information Access". Now this deals with more technical aspects of the Pactel study. As you know, we have representatives of the telecommunications industry, of the media (in other words, publishers and television networks), of the users, and also of the postal administrations and the ministries concerned. In addition, we have representatives of the CIDST: the Committee for Information and Documentation on Science and Technology. Mr CREMER is the chairman of CIDST, and this committee advises the Commission on questions dealing with Euronet. Mr FRENCH represents ISO here. The representative of CCITT was unfortunately unable to come, but he wished us the best of luck for our conference.

# TERMINOLOGY

## GENERAL DEFINITIONS

Videotex A communication system in which digitally-encoded frames are transmitted for reception by a modified TV set capable of storing and displaying a limited number of frames. Most systems have a colour capability employing the fundamentals: red, green, blue (on or off) in any combination, thereby producing eight colours: black, white, red, green, yellow, blue, magenta and cyan.

Broadcast videotex The generic name for videotex systems employing one-way communication. The entire set of frames is transmitted repeatedly, the viewer specifies what he wants, and the TV receiver selects, stores and displays the requested information. Most systems, at present, are inserting the information in the inter-frame blanking of the TV signal transmitted over the air.

Interactive videotex The generic name for videotex systems employing two-way communication. The user is able to communicate with the system to specify his requirements. Single frames are transmitted to the TV receiver, where they are stored and displayed. Most systems at present are using the public telephone network with a modulator/demodulator (modem) operating at a rate of 1200 bps from the videotex centre to the subscriber, and 75 bps from the subscriber to the centre.

Note: These definitions are not the ones being currently used within the CCITT (Comité Consultatif International Télégraphique et Téléphonique), but it is likely that this committee will adopt these definitions in the future.

## EXISTING VIDEOTEX SYSTEMS

Teletext The British system for broadcast videotex, as defined by the BBC (British Broadcasting Corporation), IBA (Independent Broadcasting Authority) and BREMA (British Radio Equipment Manufacturers' Association).

Viewdata The British system developed by the Post Office for interactive videotex.

Antiope The French videotex system, both for broadcast and interactive usage, developed primarily at the CCETT (a joint centre for TV/telecom studies in Brittany).

Telidon Canadian proposal for an interactive videotex system.

#### VIDEOTEX SERVICES (OPERATIONAL OR PLANNED)

Ceefax Broadcast videotex service offered in the UK by the BBC, based upon the Teletext system.

Oracle Broadcast videotex service offered in the UK by the IBA, based upon the Teletext system.

Prestel Public interactive videotex service offered by the British Post Office, based upon the Viewdata system.

Télétext Experimental French interactive videotex service to be offered by the French PTT in a field trial in Vélizy (Paris suburbs), based upon the Antiope system.

Bildschirmtext Experimental German service of interactive videotex, currently based upon the Viewdata system. The Bildschirmtext character generator will be specially adapted for German requirements such as the umlaut. A field trial will take place in Dusseldorf.

## LECTURE: Videotex Development in the Community

*Mr. M. Kohn, Télésystèmes, Paris*

Our presentation will summarize the results of the first part of the study that Télésystèmes has carried out for the CEC relevant to the compatibility of the various European videotex systems. Following a brief background statement about the development of videotex in Europe, we shall introduce the two major existing systems and we shall indicate the present stage of international standardization. Subsequently, we shall describe the three components of the videotex system: the terminals, the services offered (the data bases in particular) and the means of transmission.

Videotex terminology is still in a state of flux. We shall mention our ideas on this question, but other speakers may prefer to use different terminology. The word "videotex" is only a term used on a provisional basis by one of the standardization organizations, the CCITT, in order to be able to describe methods and means of retrieving information from video terminals such as TV receivers. Like the CEC, we shall use the word "videotex" for the two variants: broadcast and interactive. This introduction is based on the second variant... and we will sometimes leave out the adjective "interactive", because that's what we are mainly talking about.

Videotex standards concern the technical specifications of the various systems, such as Britain's Teletext and Viewdata, and France's Antiope. Videotex services are the experimental or commercial installations such as those that we shall now be looking at.

This chart (fig. 1) shows the major stages in the development of videotex in four EEC countries on which we have been able to obtain information. The initial ideas on videotex emerged in 1969 in the UK. This was broadcast videotex, called Teletext, and it was put out by the two broadcasting corporations, BBC and IBA, together with the radio and TV manufacturers in Britain. This led to the introduction of Ceefax in 1973, and Oracle in 1974. The Post Office studies on an interactive system, called Viewdata, started in 1972. The aim was to define a standard compatible with Teletext. These efforts, along with those of the British TV industry and of a number of information providers, made it possible to open the Prestel service in April 1979: the very first public interactive videotex service in the world.



Fig. 1 Historical background of videotex

	72	73	74	75	76	77	78	79	80	81
U. K.	VIEWDATA PROJECT (BPO)	CEEFAX (BBC)	ORACLE (IBA)				PRESTEL PUBLIC-SERVICE			
FRANCE	TIC-TAC SCT (CNET)		DIDON (CCETT)		BROADCAST ANTIOPE		ANTIOPE - METEO ANTIOPE - BOURSE		TELETEL PILOT TRIAL	
GERMANY					PURCHASE OF "VIEWDATA" (FTZ)				BILDSCHIRMTEX PILOT TRIAL	
NETHERLANDS						PURCHASE OF "VIEWDATA" (PTT)			PILOT TRIAL	

In France, the studies related to videotex also began very early. A prototype of the Tictac terminal was built in 1972 by the CNET (French National Centre for Telecom Studies). But it was in the area of broadcast videotex that results were first achieved, within the framework of the CCETT (Joint Centre for Telecom TV Studies). The multi-disciplinary nature of this research has made it possible to have a network approach for broadcast videotex, along with a common standard for the two French variants of videotex. January 1979 saw the official opening of two public services of data distribution, concerning meteorology and stock-exchange quotations. The French administration for telecommunications is now stepping up work in this area, and a pilot test of the so-called Télétel service will start at the end of 1980. An experiment involving a quarter-of-a-million telephone subscribers is planned for 1983, namely the use of an electronic videotex-based telephone directory.

Germany has adopted British standards for experiments and tests. The Bundespost is preparing a pilot trial of interactive videotex for 1980. In 1977, Germany purchased the software developed for Prestel, along with the necessary hardware, and adapted the system to the requirements of the German language. The Bundespost has nevertheless started to develop its own means for the future public service called Bildschirmtext.

In the Netherlands, the PTT acted rather similarly. In 1978 they purchased the Prestel software in order to carry out a pilot trial planned for mid 1980.

We shall now compare (fig. 2) the two interactive videotex standards resulting from parallel developments in the UK and France. This comparison must be carried out at three technical levels: first the information is coded, then it is transmitted, and finally it is displayed.

The formats of the data, on the screen, differ only by an additional row in the case of Antiope, and the maximum number of characters per row is limited to 40 in both standards. Display features are defined by means of attributes, which state the character set, the dimensions of characters, their colour and the background colour of the screen, along with various display effects. Antiope allows for several more possibilities than Viewdata. The major difference resides in the definition of these attributes and in their processing, which depend to a certain extent on the structure of the terminal. In Viewdata, all the attributes are defined at the level of character strings, which are separated by unused characters. In Antiope, most attributes are defined at the level of the character, and they are stored in the terminal in a memory that is different to that of the screen, and this makes it possible to change the display attributes quite frequently, without introducing "black holes".

Fig. 2 Interactive videotex: current standards

		VIEWDATA	ANTIOPE
DISPLAY SPECIFICATIONS	SCREEN SIZE	24 ROWS x 40 CHARS	25 ROWS x 40 CHARS
	ATTRIBUTES	ALL STRING DEFINED (BLACK HOLES)	MOST CHARACTER DEFINED EXTRA ATTRIBUTES
CODING TECHNIQUES	BASIC CHAR SET	ISO 646 (IRV IA5) - 7 BITS	
	EXTENSION SCHEME	NON - STANDARD	ISO 2022
	ACCENTED LETTERS	(PROPOSED) DIRECT METHOD	COMPOSITION METHOD
TRANSMISSION	ASYNCHRONOUS V23 1200/75 BPS		

When it comes to coding techniques, Viewdata and Antiope use the same basic character set: ISO 646. This is a 7-bit code, which doesn't allow the direct representation of all characters used in videotex, in particular semi-graphic characters and accented letters. The two standards differ in the way they extend the basic character set. Antiope respects ISO 2022, whereas Viewdata does not. The coding of accented letters is not yet standardized. Because of the presence of accents in French, Antiope had to take this matter into consideration right from the beginning, using the so-called composition method. We shall refer to this topic when speaking of standardization, and shall mention the so-called direct method proposed by the British Post Office for handling accented letters in the Viewdata system.

At the third level, that of transmission, Viewdata and Antiope are entirely compatible. They both use the public switched telephone network, in asynchronous mode, at 1200/75 bits per second.

Let us now turn to the question of the international standardization of videotex, first mentioning the main organizations concerned. This chart (fig. 3) classifies them depending on their areas of interest: text transmission, telecommunications or broadcasting. And it also divides them out according to their level of influence: national, European or international.

The international standardization organization called ISO has established, within the sub-committee in charge of character sets and coding, a work group to handle "text transmission". There are equivalent groups in the national organizations belonging to ISO. ECMA, the European Computer Manufacturers Association, is also concerned with this matter. The standardization of interactive videotex is being taken care of, at a European level, by the CEPT: Conférence Européenne des Postes et Télécommunications. And, at an international level, by the CCITT: Comité Consultatif International Télégraphique et Téléphonique. The equivalent organizations dealing with broadcast videotex are the EBU (European Broadcasting Union) and the CCIR (Comité Consultatif International des Radiocommunications). One should also note the rôle of national organizations representing radio/TV manufacturers. We have already referred to the part played by BREMA in defining Britain's Teletext standards. In France, the SCART (Syndicat des Constructeurs d'Appareils de Radio et Télévision) has defined, for future TV sets, a socket to be used for such things as videotex decoders, videotape recorders and video games.

We have already noted the compatibility of the two European standards of interactive videotex as far as transmission is concerned. As for broadcast videotex, an agreement has been reached within the EBU for the coexistence of the data structures being currently used. But efforts must be pursued

TEXT COMMUNICATIONS	ISO TC97/SC2/WG4	ECMA	BSI, DIN, AFNOR
TELECOMMUNICATIONS	CCITT SG I SG 8	CEPT	
BROADCASTING	CCIR SG II	UER/EBU	(BREMA, SCART)

Fig. 3

Standardization organizations concerned with videotex



at the display and coding levels. Progress made in relation to display characteristics is not identical for the two variants of videotex, and the EBU is currently preparing a standard that will be compatible with British Teletext and Antiope. On this point, no agreement has been defined for interactive videotex, neither at the CEPT nor at the CCITT. In the field of character sets and coding, discussions are taking place at the CCITT and at ISO on the various methods envisaged. The direct method, proposed by the British Post Office, means that every accented letter must be included in the character set, which is extended by supplementary repertoires. The composition method, proposed by six CEPT nations, including France, means that you code and transmit separately the letter and its accent. The composition, in order to create a single displayable character, is carried out by the terminal. A third method, described as multi-page, should be mentioned here for historical reasons. It was presented by Germany as a compromise solution, but has since moved towards the composition method.

We shall now describe the choices made by the various Community countries for the elements making up their interactive videotex systems, and we shall mention the terminals, the services offered, and the transmission networks.

Four types of terminals have been designed for users, while a fifth model is intended for information providers. Videotex-adapted TV sets are receivers that have either been modified by the manufacturer or plugged into an external adapter. Business videotex terminals must be small in volume, and designed as fully-integrated units. Public access terminals, located in public places, would be activated by coins. These three kinds of terminals are already being marketed for Prestel. The domestic videotex terminal is an integrated compact apparatus, designed for individual users. An example is the small terminal to be distributed free to telephone subscribers in France, replacing the printed directories. Among the various kinds of editing terminals, the simplest is an adapted TV set that has a special keyboard making it possible to directly code display attributes during the composition of information pages.

In order to transform a TV set into a videotex terminal, three main pieces of equipment have to be added. A decoder takes care of information encoding and decoding, and controls display. Then a modem converts the analogue signals of the telephone into digital data, and vice versa. Finally, a compact keyboard makes it possible to dialogue with the videotex service. The choices of three European PTTs are summarized in fig. 4. For Prestel, most terminals are TV sets containing a decoder and a modem, and equipped with a small numeric keypad. In the future German Bildschirmtext service, the terminal will house the decoder, but the modem will remain outside. The French terminal for Télétel will be a

	DECODER	MODEM	BASIC KEYPAD
PRESTEL	INTERNAL	INTERNAL	NUMERIC
BILDSCHIRMTEXT	INTERNAL	EXTERNAL	NUMERIC
TELETEL	EXTERNAL	EXTERNAL	ALPHANUMERIC

Fig. 4 Converting a TV set into a Videotex terminal

normal TV set, with external adaptations. The keyboard, of a reduced size, will enable users to key in alphabetic characters as well as numbers.

We refer you to our study report for a discussion of the advantages of microprocessor technology in the manufacture of videotex decoders. (See fig. 5.) Here we shall mention only the flexibility that can be obtained through programming. This makes it possible to use the same equipment for different standards... or to develop bi-standard decoders for Viewdata and Antiope (which has already been done).

Let's now look at the services that can be provided: in particular, data bases. Information retrieval is in fact the main purpose of videotex systems. However one should not forget the conversational nature of interactive videotex, capable of being used for transactional applications in each of the European services.

There is a common feature in the organization of data bases, namely, the tree structure that guides the user from a general description of the contents right up to the exact page of information he wishes to find. With Télétel, retrieval possibilities will be particularly powerful, because of the use of alphanumeric keyboards.

At present there is no common access language for the various European videotex services. In the French service the number of commands is greater, because special characters are used along with the conventional asterisk and lozenge of the numeric keypad.

The third technical aspect of interactive videotex is data transmission. The public switched telephone network is used in each European service to connect terminals to videotex centres. But major differences concern the private or public nature of these centres, and their interlinks.

In the UK (fig. 6), Prestel incorporates regional centres managed by the Post Office, which will eventually be interconnected. These public centres contain the data bases prepared by information providers. The extension and development of these data bases are carried out by an updating centre.

The German telecom administration also envisages a network of regional centres (fig. 7), to constitute the Bildschirmtext service. These public centres will contain several data bases, but most data will be located in private centres linked to the public ones. In other words, the public centres might be thought of as intermediaries between the terminals and the private centres.

The future Télétel service planned by the French telecom (fig. 8) includes, above all, private videotex centres. Local

Fig. 5 Microprocessor-based Videotex decoder

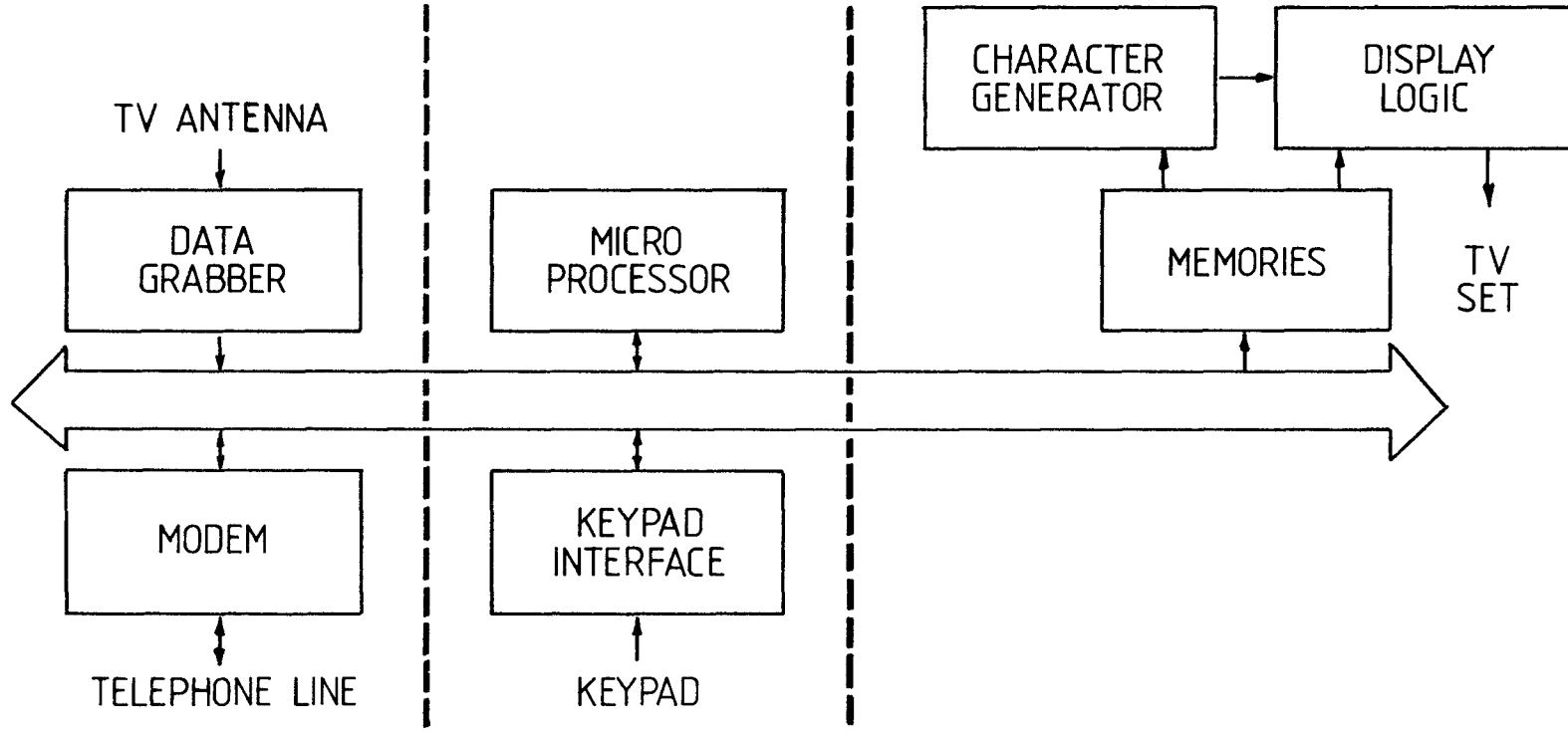

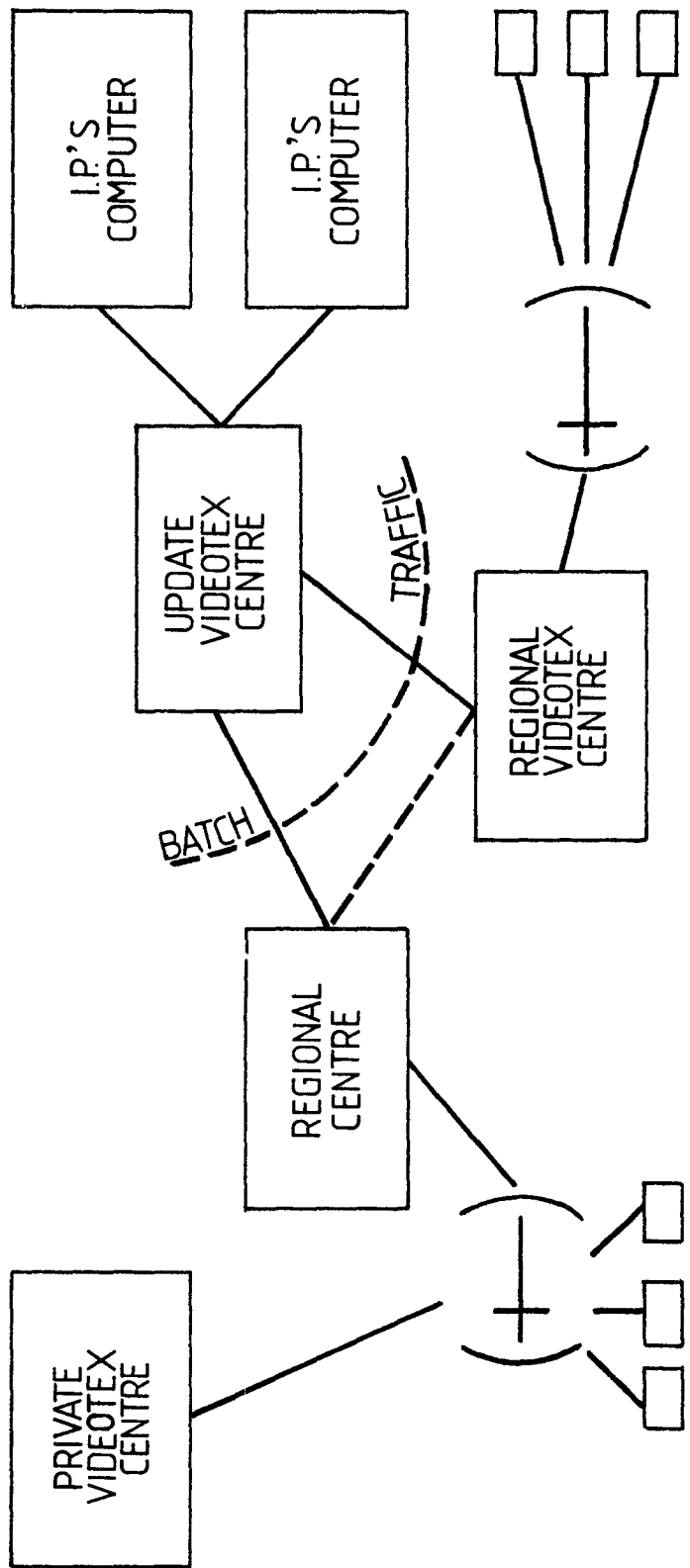

Fig. 6 British network architecture

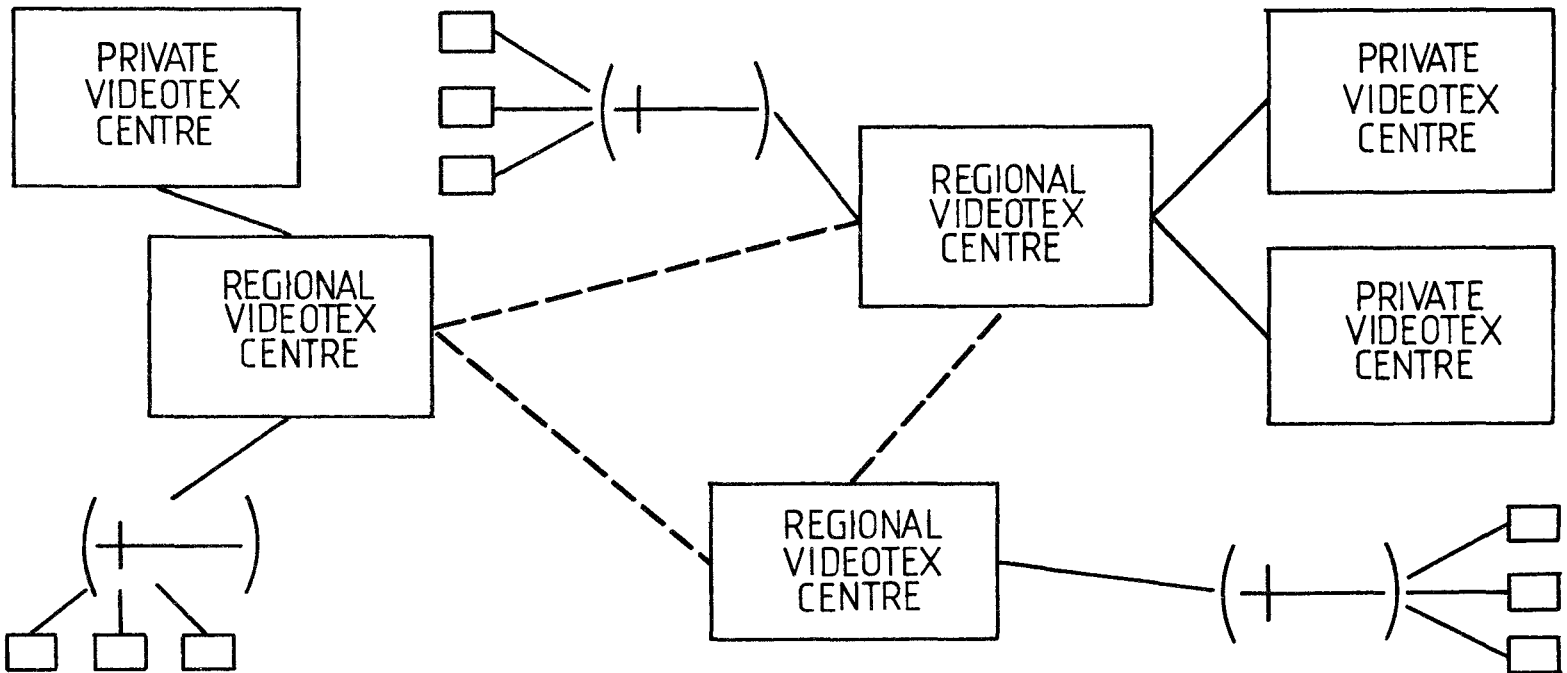

Fig. 7 German network architecture

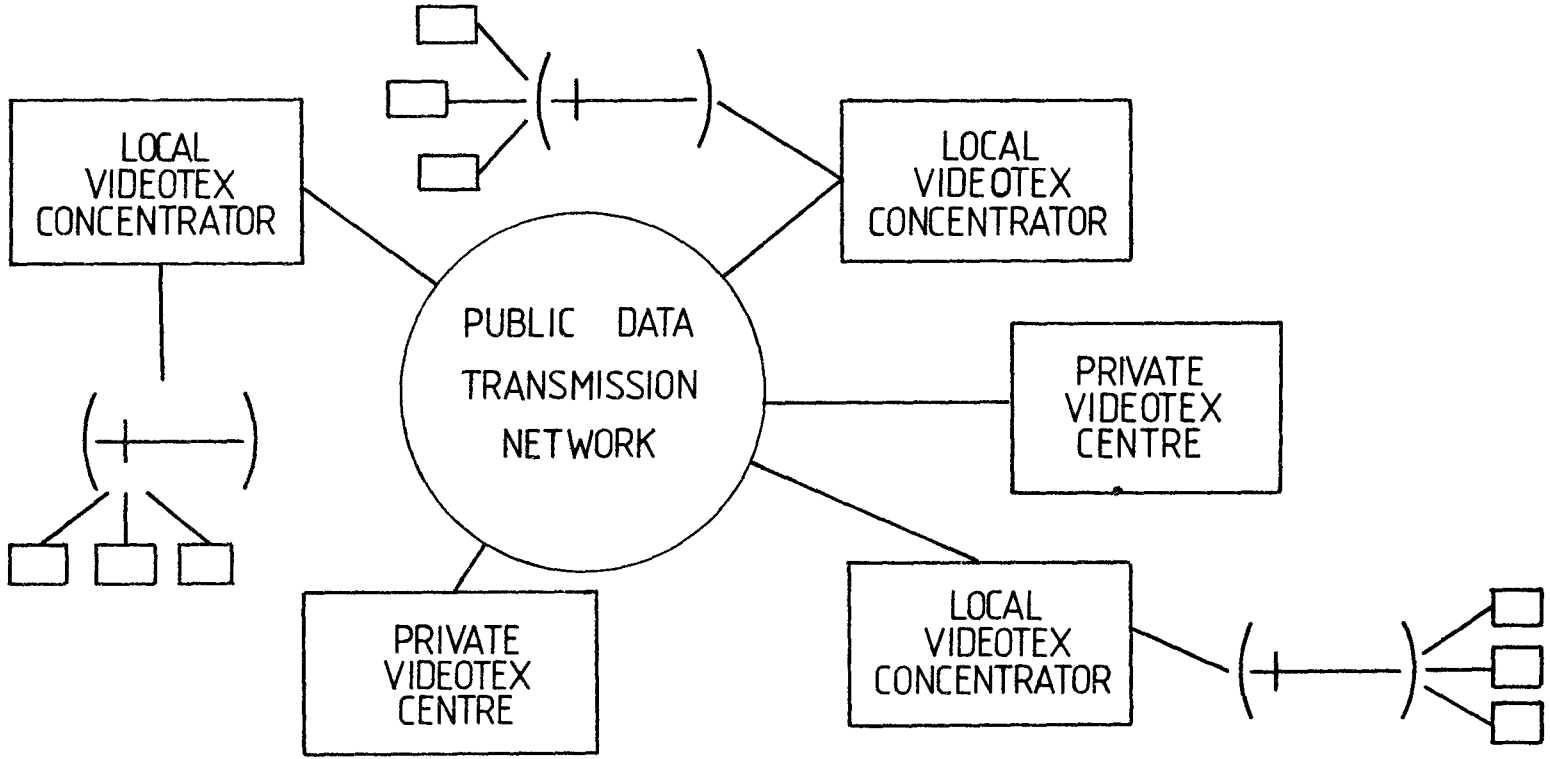

Fig. 8 French network architecture

concentrators will enable terminals to access these private centres through a public data-transmission network such as Transpac. However, for the pilot trial of Télétel, the terminals will directly access equipment making it possible to get switched towards local data bases and services or towards remote private centres.

To sum up, the history of videotex shows that this is a technique that was born in Europe, then developed both in the UK and France. And this technique is coming to interest more and more Community nations. The British have acted as pioneers in this field, by creating the first commercial applications. As for the French, they have attempted to tackle the problem of the compatibility between videotex and other existing and planned means of data transmission, as well as with text transmission systems.

It's obvious that common standards would facilitate the development of videotex within the Community. The standardization must be based on the developments that have been undertaken so far, but it must also take into account the rapid development of technology. Furthermore, it must allow for extensions such as those proposed by newcomers to the videotex field: Canada, the USA and Japan.

The latter part of our study demonstrates the possible use of the Euronet network in the context of interactive videotex services. (See fig. 9.) You will find, in our study report, different technical solutions that might be envisaged for establishing liaisons between European videotex services.

Finally, I should add that our study report expresses solely the opinions of Télésystèmes. We carried out this study in an independent manner, nevertheless taking into account various comments put forward by the Commission. Thank you.



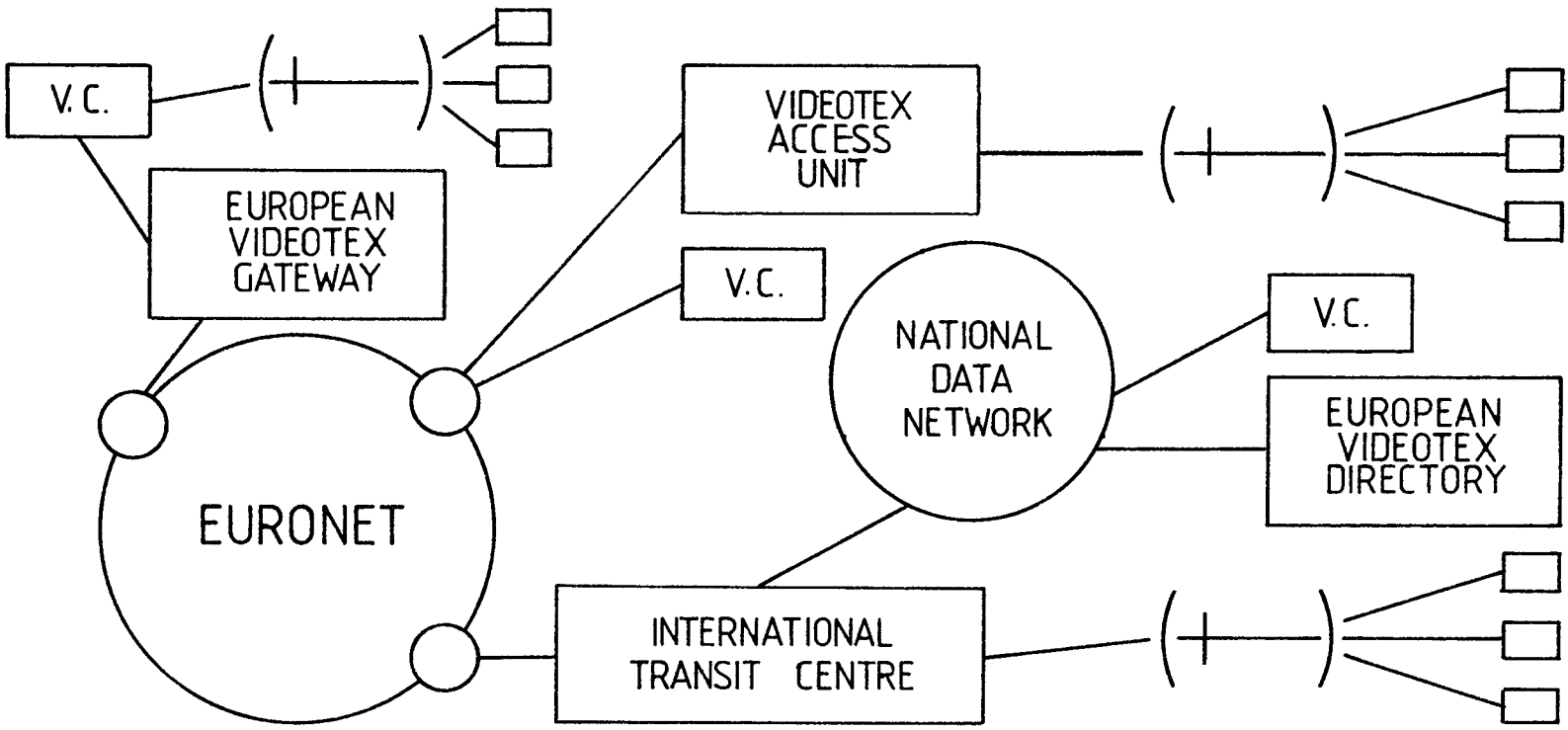

Fig. 9 European videotex/Euronet interfaces

## TEXT: Videotex/Euronet Compatibility

Summarized extracts from the study report:

### *Télésystemes, Paris*

#### VIDEOTECH IN THE UNITED KINGDOM

##### History

Four organizations have been active in the specifications of the British videotex standards and in the development of related services:

- the two broadcasting organizations, BBC and IBA, for the broadcast standard Teletext;
- the British Post Office, for the interactive standard Viewdata;
- the BREMA, representing the TV industry.

Information providers, who recently formed an independent association (the AVIP), have also been involved in the definition of the Prestel service.

The following list presents a chronology of major events for both types of services:

- October 1969 : First proposal for Viewdata, agreed to in May 1971 after a preliminary design study.
- December 1970 : First BBC memorandum on the possibility of displaying data on the screens of domestic TV sets.
- February 1971 : Work schedule, drawn up by the BBC, for a new broadcasting service called at that time Teledata (first published brochure in May 1972).
- January 1972 : Initiation of a formal Viewdata project, and beginning of the work two months later.
- September 1972 : First paper by the IBA on "a system of data transmission in the vertical field interval of the television signal".
- October 1972 : Announcement of Ceefax (renamed Teledata service) by the BBC.

- January 1973 : Issue of draft Viewdata standard specifications.
- April 1973 : Release of details on the specifications for the experimental Ceefax service by the BBC, and of the Oracle service by the IBA (same principles but several technical differences).
- July 1973 : Opening of the experimental Ceefax service, with the first transmission of a magazine in September 1973.
- May 1974 : Formal launching of Oracle by the IBA.
- September 1974 : Joint publication of a unified standard by the BBC, IBA and BREMA, following agreement in March 1974 by the committee of representatives of the three organizations, which had been set up around the middle of 1973.
- May 1975 : Agreement on coding amendments to accord with ISO 646 "7-bit coded character set for information processing interchange", to make the specifications more acceptable internationally. The BBC and IBA switched to the new code table in April 1976.
- September 1975 : Formal announcement of Viewdata.
- January 1976 : Publishing of the final "broadcast Teletext" specifications" including new control characters (graphics hold, double height, background, separated graphics) by BBC, IBA and BREMA.
- September 1978 : Opening of the Viewdata test service, replacing the planned market trial, under the name of Prestel.
- Spring 1979 : Start of the regular Prestel public service by the UK Post Office.

From an early date, both Teletext and Viewdata systems have been demonstrated abroad. Field trials of UK Teletext were carried out in Munich (Germany) and in Stockholm (Sweden) in April 1975. Both the Swedish Broadcasting Corporation (since 1975) and the Danish television network (since autumn 1975) have been conducting such trials. In January 1979, tests were performed in the Netherlands. Viewdata has been successfully demonstrated in Brussels (January 1976), in Darmstadt (February 1976), in Paris (April 1976), in Geneva for the CCIR (May 1976), in Copenhagen (September 1976), in Florence for the CEPT (November 1976), and in Berne (November 1976).

Three countries have subsequently decided to acquire the UK's Prestel software and expertise. The Bundespost bought it in January 1977. The Netherlands Postal and Telecommunications Authority announced the signing of a contract with the UK Post Office in June 1978. In addition, the Danish and Swedish PTTs have been experimenting with Viewdata via international telephone line connexions to the Prestel service. The Hong Kong Telephone Company, which has also acted in this manner, is planning to launch a Prestel-like service in the near future. Prestel has also been demonstrated in the USA, since March 1978, by INSAC, a USA-based company created by the UK's National Enterprise Board in order to market British computer systems and software overseas. This firm has been aiming to sell the Prestel software and know-how in the USA.

The history of British videotex developments reveals:

- an early search for compatibility between various standards, developed by the different broadcasting and telecommunications organizations;
- the major involvement of the TV and electronics industry.

Although they were based on the same principles, Ceefax and Oracle had different technical implementation characteristics in 1973. The BBC, IBA and BREMA subsequently agreed upon a common standard, allowing a higher bit rate. When the Post Office joined the working group, it required that the Viewdata standard be compatible with the unified standards.

The manufacturers of TV sets have been playing an important rôle in the definition of this standard. To simplify receiver design, the manufacturers were anxious to devise a standard in which the data for rows of 40 characters could be transmitted on a single television line.

The pioneering developments of the BBC, the IBA, the UK Post Office, and the British radio and electronics industry have led to the world's first regular public videotex services: Ceefax and Oracle in 1974, and Prestel in 1979.

## Present status

### (a) Ceefax and Oracle

Ceefax is in operational service, and is broadcast by the BBC on the first two British television channels. Oracle is IBA's service, on the third channel. Each channel provides about 100 pages of information. The number of installed Teletext TV sets is about 10,000.

### (b) Prestel

The public service is due to start in the spring of 1979 with the opening of two new centres, in addition to the centres in London and Birmingham that are used for the test service. There are multiplexors connected to the nearest computer centre in three other cities. Present commitments are for about ten computer centres by the end of 1979. Each computer centre is equipped with a dual configuration of GEC 4000 series medium-scale processors, with software developed by the Post Office.

Customers and on-line editors use 1200/75 bps lines of the public switched networks. "Bulk updates" can be received on 2400 asynchronous lines or on magnetic tapes. Figures 1 and 2 show the dual configuration of a computer centre and the initial locations of Prestel centres.

About 170 information providers have booked nearly 200,000 pages. The whole British TV industry is involved in the production of Viewdata/Teletext sets, and a dozen TV manufacturers had started production of sets by the end of 1978. LSI circuits for the decoders are produced by three manufacturers: GEC, Mullard and Texas Instruments UK.

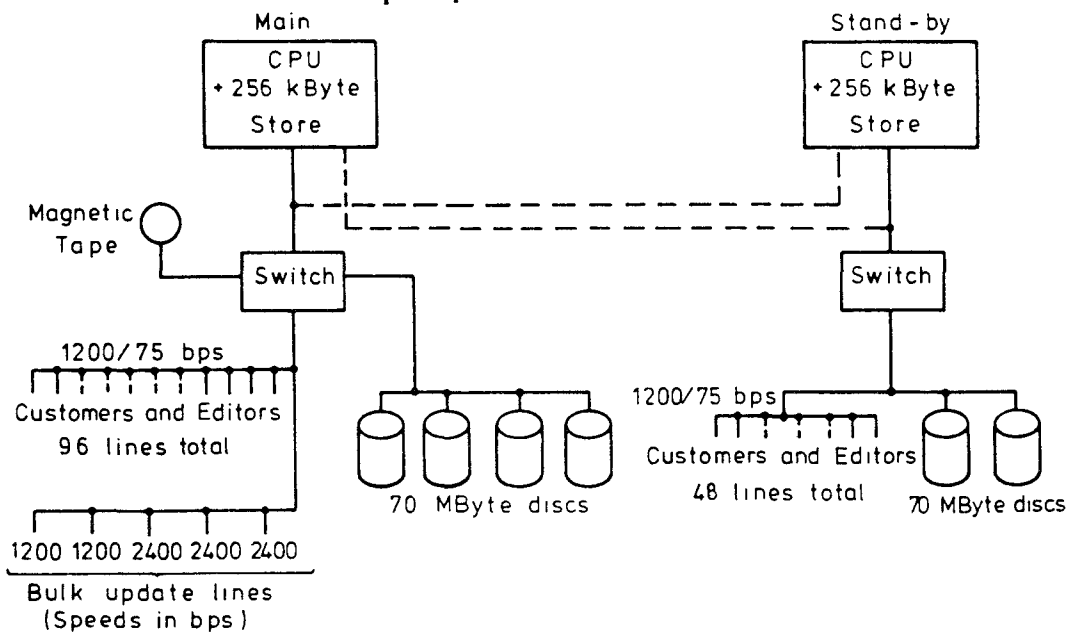

Fig. 1 Dual configuration of a Prestel computer centre

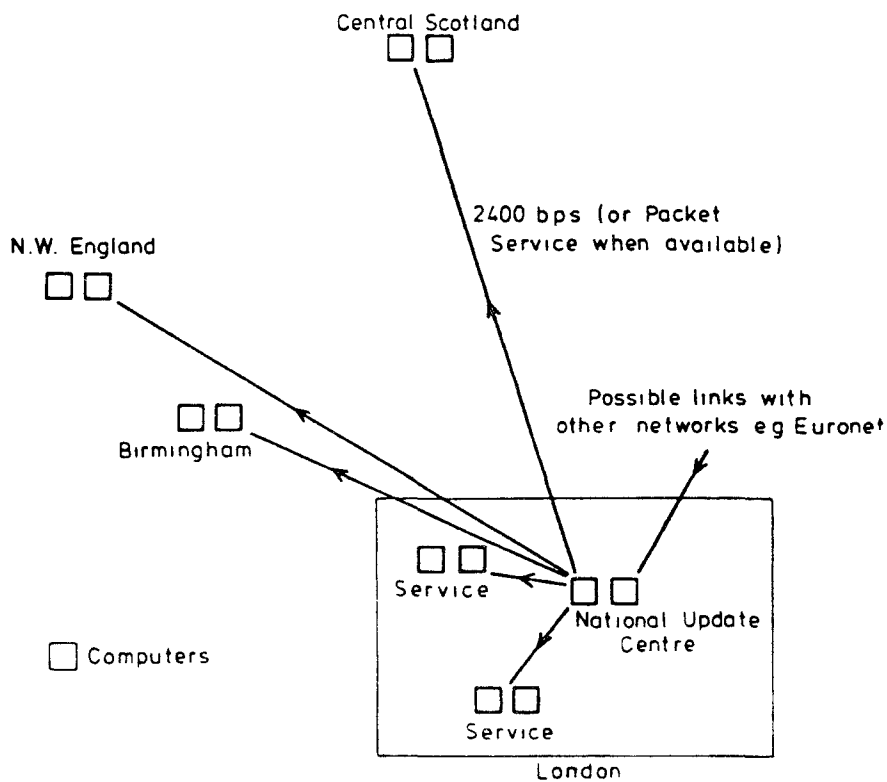

Fig. 2 Initial locations of Prestel centres

## VIDEOTECH IN FRANCE

### History

Development has been carried out by the authorities in charge of telecommunications and broadcasting. The French PTT has its own research centre, the CNET (Centre National d'Etudes des Télécommunications). TV broadcasting responsibilities are split between three companies: TF1 (Télévision Française 1), A2 (Antenne 2) and FR3 (France Régions 3). Broadcasting facilities are provided by a company called TDF (Télédiffusion de France). These organizations, along with two others, have been created from the former broadcasting authority called the ORTF. In 1972, the PTT Administration and the ORTF formed a common research centre for telecommunications and television (CCETT: Centre Commun d'Etudes de Télévision et de Télécommunications), located in Rennes in Brittany.

We shall use the common term "French Administration" for the various authorities in charge of the development of videotex services in France. Major events can be summarized as follows:

- December 1971 : Start of preliminary studies on low-cost home terminals (message display, speech, synthesis...) at the CNET.
- December 1972 : Completion of prototypes of Tic-Tac terminals, using a standard TV set and a touch-tone telephone receiver. A modem allowed them to be connected through the public telephone network to the experimental service called SCT (Service de Calcul par Téléphone = telephone-based computing service). Terminals of this sort manufactured in 1973 have been used internally by the French PTT Administration.
- September 1973 : Start of studies on data broadcasting at the CCETT, under the name of "Télépresse", leading to the creation of a first receiver prototype by mid-1975.
- Spring 1975 : New orientation of the studies at the CCETT under the name of "Télétexte", leading to the Didon concept.
- January 1976 : Convergence of work carried out by the CNET and the CCETT. The Tic-Tac terminal adopted a full keyboard instead of the telephone keypad, and evolved to the existing specifications of Antiope.
- March 1976 : Broadcast Antiope equipment available for the first time.

- September 1976 : First public demonstration of broadcast Antiope at the "Sport 76" exhibition in Moscow, where the 1980 Olympic Games were being prepared. One complete day of the Games' announcements and results was simulated in French, English, German and Russian. Another demonstration took place at the VIDCOM exhibition in Cannes.
- February 1977 : Start of the development of the interactive version of Antiope at the CCETT.
- May 1977 : Experimental opening of the broadcast Antiope-Bourse service (stock exchange data).
- June 1977 : Demonstration of the Antiope version adapted to the North American 525-line TV standard at the TV biennial exhibition of Montreux.
- September 1977 : First public demonstration of the interactive Antiope standard, together with the broadcast system and the audiographic videotex standard (see below) at the "Funkausstellung" (International Radio and Television Exhibition) in Berlin.
- February 1978 : Decision made for the pilot trial of an interactive videotex service by the French PTT Administration.
- March 1978 : PTT makes a decision for the "Electronic Telephone Directory" project, using low-cost mass-produced videotex terminals.
- Mid 1978 : CNET starts new studies on videotex terminals comprising standard TV sets with decoders connected to the aerial socket, and allowing pseudo-coloured displays. Other studies are concerned with an enlarged SCT service (now meaning Service de Consultation par Téléphone = consulting service by telephone) based on the SEMS T1600 and Solar 16 mini-computers.
- October 1978 : The SCART (French radio and television equipment manufacturers' association) issues the specifications of the interface between so-called "peri-television" devices and mass-market TV sets.
- November 1978 : Start of the experimental broadcast service called Antiope-Météo (weather reports).
- January 1979 : Antiope-Bourse and Antiope-Météo become public services.



France has been active on the international scene, in standardization organizations and, more recently, in negotiations aimed at exporting their standard. The subject of Teletext standards was introduced in May 1976 to the International Broadcasting Consultative Committee (CCIR) by French representatives, who then took an active rôle in each of the standardization organizations involved.

Efforts have been made to export Antiope to North America and to other European countries :

- In spring 1978, a large-scale demonstration of both versions of Antiope took place in the USA (New Orleans) and Canada (the interactive system in Montreal, and the broadcast system in Ottawa). Since then, agreements have been made with Canada for co-operating in the videotex field. There is also an agreement with CBS, the American TV company, for an experimental service. CBS will operate a test service in Saint Louis (Missouri) using the Antiope standard, which it will sponsor on submission to the Federal Communications Commission (FCC).
- In Europe, tests of Antiope and comparisons with UK Teletext standards were performed in January 1979 in the Netherlands by the NOS Broadcasting Authority, and in Switzerland by the PTT Administration.

French developments in the field of videotex standards have been influenced by an interdisciplinary environment and by the need to handle an extended alphabetic.

- The CCETT is a research centre developing techniques for new transmission services, using telecommunications or broadcasting means (numerical television, large bandwidth delivery, new audiovisual services, data communications networks). The specifications of the Transpac network were defined by the CCETT on the basis of its experimental network called RCP. The choice of a network approach, ever since the design phase of the broadcast Antiope standard, can be explained by the fact that telecommunications and broadcasting engineers work together at the CCETT.
- The French language - like other European languages, but unlike English - uses diacritical marks and special characters. The specifications of the French videotex standards therefore took account of these linguistic aspects at an early stage.

## Present status

### (a) Broadcast Antiope

No public broadcast videotex service is available in France. TV programme companies are however studying and planning such services. French broadcasting authorities have preferred to start with two dedicated services which are now fully operational:

#### - Antiope-Bourse

The broadcast Antiope-Bourse magazine offers pages of stock exchange information, which are updated in real time when transactions are occurring. Two dedicated broadcasting stations transmit to the Paris and Lyons areas, over telephone lines, the pages stored in the computers of the Stock Exchange Brokers' Association.

#### - Antiope-Météo

The broadcast Antiope-Météo magazine provides weather reports and forecasts, using coloured maps, to selected subscribers from such fields as the building trade, transport, agriculture, energy...

#### - A third dedicated system is being set up for the OREP (Office Régional d'Education Permanente), a regional education authority. Its objective is to provide relevant information on the social and economic development of the south-west Aquitaine region of France.

#### - Another variant of the broadcast standard that should be mentioned is audiographic videotex. This has mainly been used to demonstrate Antiope capabilities, but it could be used for educational programmes. Using a radio channel, this standard allows synchronized broadcasting of videotex pages and of a related audio programme. This technique, which uses a bandwidth 50 times narrower than for television, could lead to less costly transmissions in appropriate applications.

(b) Interactive Antiope

Two experimental services have been developed:

- Titan at the CCETT (see fig. 3 for its configuration).
- SCT at the CNET.

Work is under way on the preparation of the pilot trial of an interactive public service, which will take place in the Paris suburb of Vélizy in late 1980. This trial aims to study the design and production of videotex decoders, and will provide an opportunity for developing special applications. Several actions are being carried out by the French PTT before starting the pilot trial: search for information suppliers and the setting up of a provisional testing standard, technical developments and talks with terminal manufacturers. LSI circuits are being manufactured for decoders by three electronics companies: Texas Instruments France, Thomson/EFCIS and Philips/RTC. As explained above, the CNET is also developing its own videotex add-on device with the aim of using existing television sets without the new SCART socket.

Another project already under way could have a large impact on videotex services. The French PTT intends to supply phone subscribers, free of charge, with small videotex terminals instead of printed directories. The test trial is due to start in 1981. The project has begun with a call for tenders concerning the construction of compact monochrome terminals. Certain manufacturers claim to be able to descend to the mass-production target cost of around 300 French Francs (the equivalent of about 35 or 130 DM).

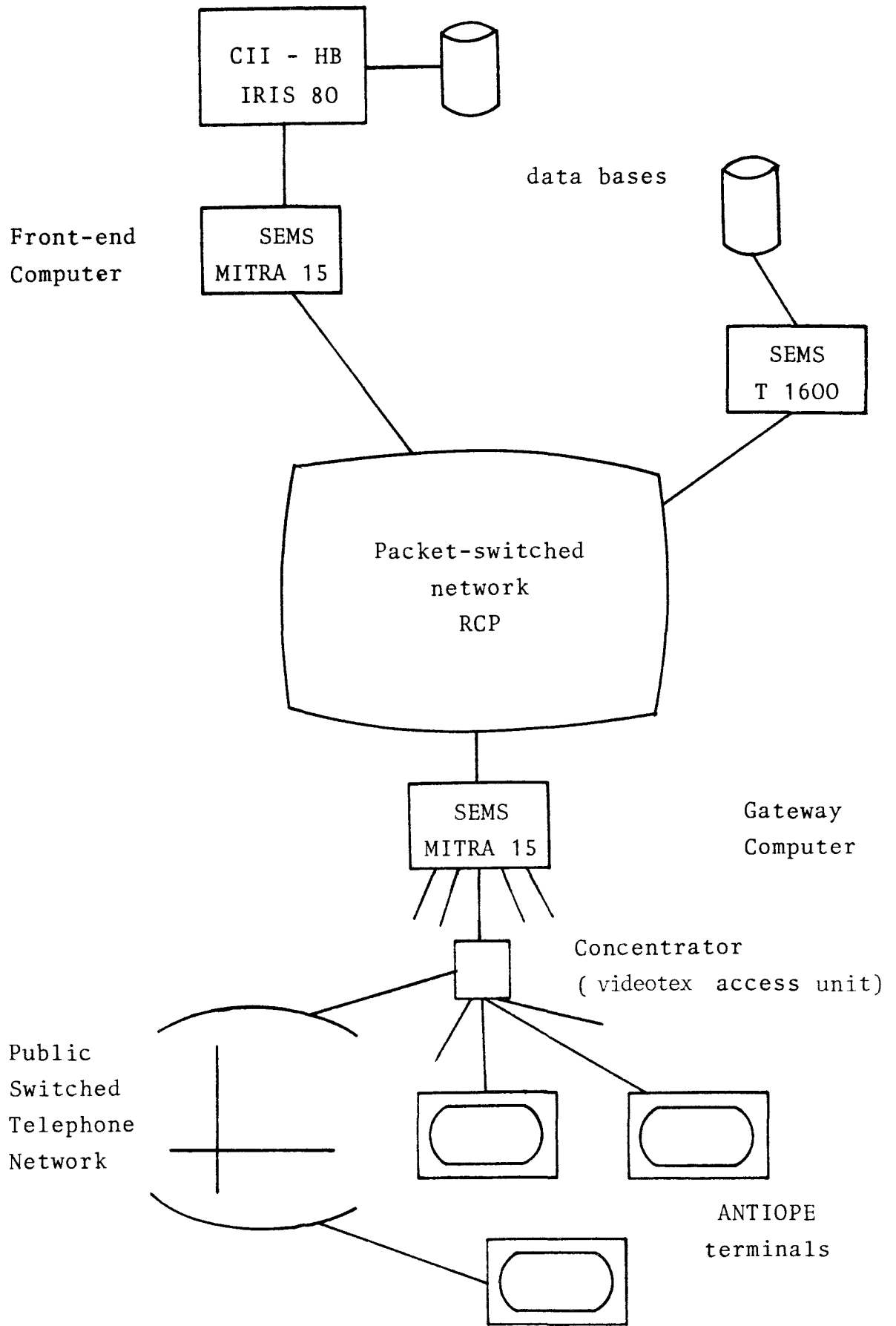

Fig. 3 Configuration of the experimental Titan service

## VIDEOTECH IN THE FEDERAL REPUBLIC OF GERMANY

Experiments for developing videotex services have been carried out by the telecommunications and broadcasting authorities. In Germany, telecommunications operations are managed by the Deutsche Bundespost (the German PTT). Its telecommunications engineering centre - Fernmeldetechnisches Zentralamt (FTZ) - is located in Darmstadt.

Among the TV broadcasting organizations interested in videotex, there are the two major television companies - the ARD and the ZDF - and the broadcasting engineering centre in Munich: the Institut für Rundfunktechnik (IRT).

Main events in the adaptation of British Teletext and Viewdata standards in Germany are summarized as follows:

- April 1975 : Tests with the Teletext system, carried out by a joint BBC/IBA/IRT team in Bavaria.
- February 1976 : Demonstration of Viewdata at the FTZ.
- January 1977 : Purchase by the Bundespost of the Prestel software and expertise from the British Post Office, and of a GEC 4080 computer.
- September 1977 : First public demonstration at the International Radio and Television Exhibition (Funkaustellung) in Berlin of the experimental broadcast videotex service called Videotext, and of the interactive videotex service, called Bildschirmtext, being developed by the Bundespost.

Today, experiments and measurements on the broadcast Videotext service are being carried out. A pilot trial of the Bildschirmtext service is being prepared for 1980, with the following objectives:

- Demonstration for interested parties from business and industry: information providers and TV set manufacturers.
- Market research.
- Technical developments for adapting the system to the German language, and for connecting private computers.

A version of the Viewdata decoders has been designed to accept special German alphabetic characters (within the national space of the IRV of International Alphabet n° 5). The Bildschirmtext service will allow access not only to data bases stored on computers run by the Bundespost, but also to data bases stored on private computers that are linked to the former machines. Work is initially being carried out to implement such connexions to IBM computers.

## OVERVIEW OF POSSIBLE SOLUTIONS FOR EURONET/VIDEOTECH INTERFACES

We shall examine, one after the other, various solutions that might be envisaged for the different cases of use of the Euronet network in European videotex services, and finally we shall summarize requirements in interface equipment.

### Interfaces for Interchange Between Videotex and Euronet Services

Progress in various European countries, based upon certain specific architectural choices concerning their future videotex services, forces us to envisage three major types of interconnexion with Euronet:

- access via a national videotex service,
- access via a national data-transmission network, and
- direct access to Euronet.

#### Access Via a National Videotex Service

This type of interface, making use of a gateway, is suited to the case of Germany's Bildschirmtex service, as explained in section 5.1, and it could also be used in Britain's Prestel service and in the future videotex service of the Netherlands.

It can be said, in general terms, that this type of interface concerns all the countries that allow terminals to call only the nearest videotex centre or to access the videotex service via a national data-transmission network which is not connected to Euronet.

The principal function of the European Videotex Gateway would be the interface with Euronet for the management of access to foreign services. This gateway would include the European Videotex Directory, and would be able to carry out conversions and play a rôle in billing.

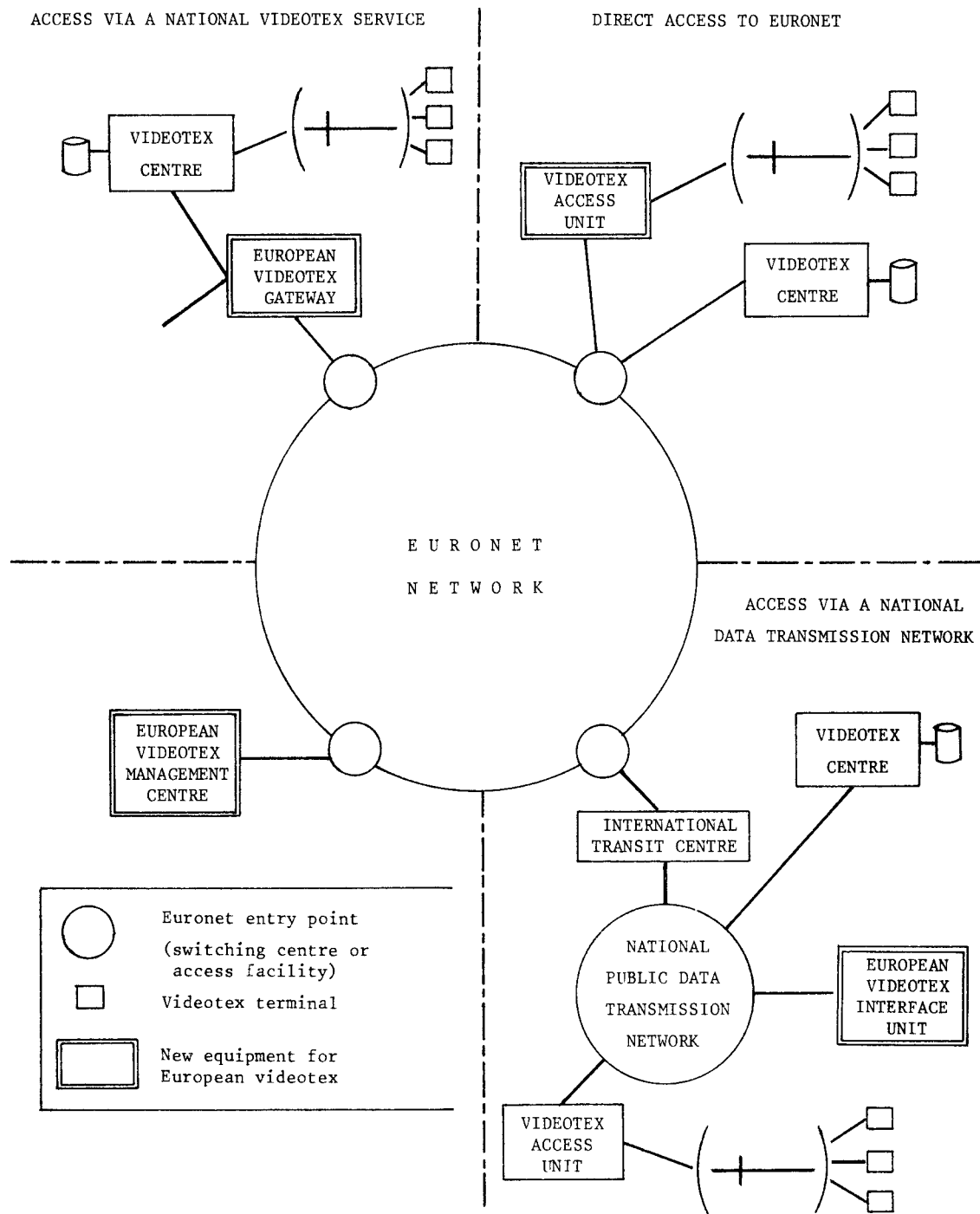

Fig. 4 European videotex/Euronet interfaces

### Access Via a National Data-Transmission Network

This type of interface would be most suitable for the Teletel service, if current plans are carried out for a wide distribution of access equipment, the functions of which would be quite separate from the functions of the videotex centres.

The use of the Transpac packet-switching national public network, with its mode of connexion to Euronet through an international transit centre, is typical of this solution.

The only new equipment required for accessing foreign videotex services would be the European Videotex Interface Unit, which includes the European Videotex Directory. The conversion function could be centralized in this equipment, unless it had already been incorporated in all of the videotex access units (which would be the better solution from a performance point of view).

Besides the time taken for conversions, this solution would extend the response time insofar as all communications outside the country must pass through this interface equipment.

### Direct Access to Euronet

This solution applies to any European countries that:

- are not in the process of developing a German-type national videotex service, and
- are not equipped with a national public packet switching data transmission network.

The terminals, although capable of accessing the videotex centres through the PSTN, can use the latter to be connected to Euronet. The videotex centres, that might already be Euronet Diane hosts, can be connected directly to Euronet.

As we mentioned earlier, the PAD function of Euronet entry points, for the interface with asynchronous TTY-compatible terminals, is not sufficient for access by videotex terminals. This makes it necessary to use a Videotex Access Unit, which takes into account all the management functions of access to videotex services and of interfacing with Euronet, along with the possibility of the conversion function. If this equipment is unique, it should include the European Videotex Directory, otherwise this and the conversion function could be centralized, as in the previous case, in a European Videotex Interface Unit.



## Feasibility of a Unique Solution for the Different Types of Interfaces

We have used different names to designate the equipment necessary for the various types of interface between the videotex services and Euronet. However, the description of the functions of each one shows, as is indicated in figure 5, that they share many common features.

Functionally, the European Videotex Interface Unit (for access via a national data-transmission network) can be considered as a subset of the European Videotex Gateway (for access via a national videotex service), and the latter is itself included in the European Videotex Access Unit, which carries out all the functions mentioned (except the interface with a national videotex centre).

The adaptation function for TTY-compatible terminals and videotex centres can be carried out by each of them. Only the adaptor unit for linking videotex terminals to Euronet Diane hosts has a basic function that differs from the others, in that it is closer to the host's particular characteristics.

Although their dimensions will be different, because of constraints concerning the traffic, it would be possible to build all this equipment starting with the same modular elements, using software that would be partly common.

However, some priorities have to be allocated when starting such a development project. Moreover, although the three solutions are the outcome of different choices in the design of European videotex services, one might like to select the technically best approach. Thinking in terms of the current trend towards distributed systems, one might prefer the "access unit" rather than the "gateway" for modularity and security reasons. This solution is suited both to the direct access of videotex terminals to Euronet, and to their connexion via a national data-transmission network. It also implies a smaller quantity of equipment between the terminal and the foreign videotex centre, which could result in better response times.

Functions \ Equipment	European videotex interface unit	European videotex gateway	European videotex access unit
User identification			x
Dialogue for selection of a specific service			x
Linking to the desired service		x	x
Generation of service data and remote control of the terminal			x
Billing		x	x
Interface with the Euronet network		x	x
European videotex directory	x	x	x
Videotex standards conversions	(x)	(x)	(x)
Teletype / videotex conversions	(x)	(x)	(x)

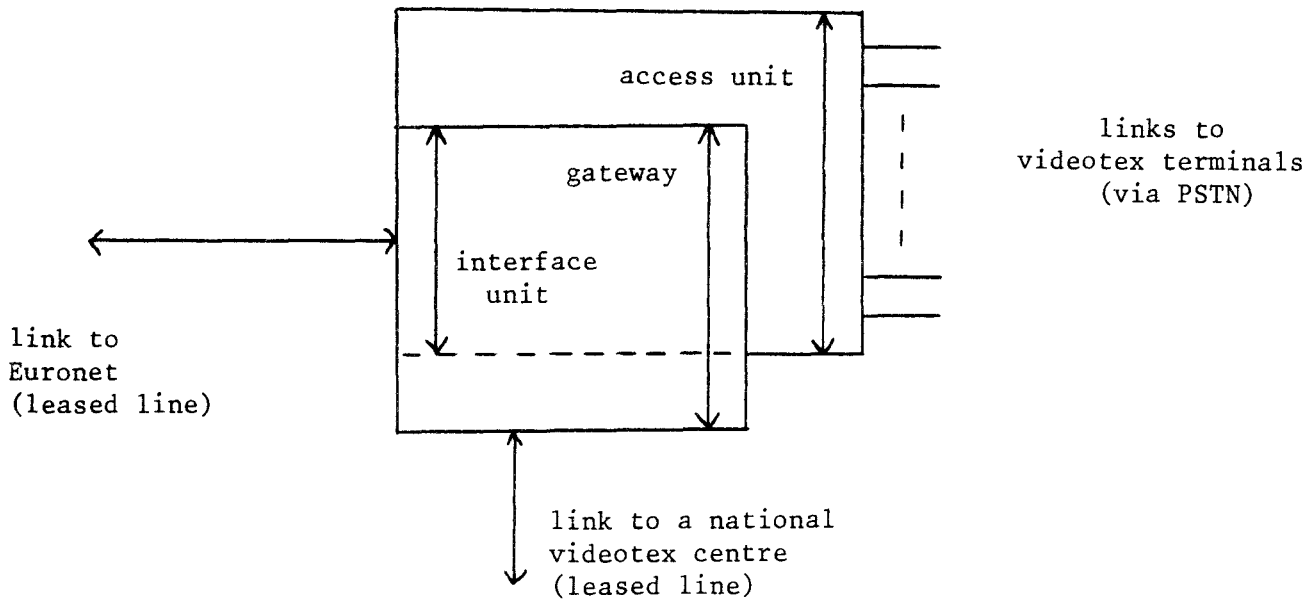

**Fig. 5** Functions of different types of Euronet/videotex interface equipment

## SYNTHESIS AND RECOMMENDATIONS

### PRINCIPAL RESULTS OF THE STUDY

The present study has shown that the interworking of videotex and Euronet is both desirable and feasible.

Just as each country's data transmission network might play a rôle in interactive videotex at a national level, the Euro-net telecommunications network might be a very useful tool at a European level. Moreover, insofar as Euronet Diane services are not competitive with respect to videotex, they could well be used to provide videotex-type information.

Although there are still different national policies in Europe for the architecture of videotex services and for the design and manufacture of videotex terminals, their inter-connexion through Euronet is technically feasible.

Euronet and videotex services might be made to work together in an easy and not-too-costly manner... but this will depend to a large extent on the success of standardization efforts. In other words, the Commission of the European Communities is faced with a double task:

- Carry out effective actions, immediately, to ensure that Europe agrees upon a common videotex standard; and
- start the development of necessary interface equipment, as soon as possible.

The convergence on display characteristics that has occurred in broadcast videotex could probably be extended to cover interactive systems, but agreement on coding standards and character sets will be more difficult to achieve. On the one hand, there are those who want compatibility with the synchronous fixed-format British Teletext system... and this attitude is based, to a large extent, on the desire not to waste the investments already made in this field. On the other hand, there is the possibility of using the flexibility of an asynchronous free-format mode of transmission of interactive videotex combined with information-coding characteristics which would both respect international standards and also allow interworking with other text communication services.

Before a common standard is obtained, immediate developments for the interconnexion of European videotex services will have to admit the existence of two standards: Viewdata and Antiope. The required conversions between a videotex terminal and a videotex centre that do not use the same standard can be carried out either at the terminal end or at the centre... or even during the network transmission phase. Current technology makes it possible to create videotex decoders that could take care, simultaneously, of several different stand-

ards and many different character sets... which would in fact allow us to adopt the solution of a double-standard terminal, not requiring conversions.

Teletype-compatible terminals (the most common variety of I/O device used for accessing Euronet Diane hosts) could be used, together with an appropriate interface, to access videotex data bases, but many of the natural advantages of this new information retrieval medium - such as colour and block graphics, for example - would be lost in such cases.

If interface devices can be produced that respect the limited dimensions and the special format of videotex screens, then videotex terminals should be able to access STI data bases. Obviously, this technique would become interesting only if specific videotex data bases could be created using the data stored by Euronet Diane hosts.

Direct connexion of videotex terminals to the PAD facility of the Euronet network is only possible when a full keyboard is available. Videotex requires supplementary access functions that might be taken care of by Videotex Access Units, which could be accessed more easily than the PAD. Network interfaces of this kind would therefore be more suitable for most domestic users.

It is not always possible - for reasons related to the fundamental choices made by videotex authorities - to connect videotex terminals, via the PSTN, to such units, for accessing Euronet or the national packet-switching network (as in France). In such cases (for example, in Germany), videotex terminals can be linked to videotex centres only, and connexions with foreign videotex services could only be made through a gateway.

The existence, at the videotex terminal level, of a complete alphanumeric keyboard, is vital for accessing today's STI data bases. It will be possible, thanks to such a keyboard, to carry out information retrieval on data bases that are not necessarily tree-structured, and to benefit from many types of transactional services. In such a case, videotex use will be slightly more complex than with a numeric keypad, but there is no doubt whatsoever that tomorrow's citizens will be accustomed to such tools.

#### RECOMMENDATIONS FOR FURTHER ACTION

European telecom administrations, having decided to look into the advantages of public videotex services, have already carried out various pilot trials involving this new medium. We feel that the CEC should adopt this same strategy concerning the question of the interconnexion of these services, and the possibility of a European interactive videotex service.

This would make it possible, within a limited but quite real environment, to find solutions to most of the technical, political and administrative problems posed by European videotex. The rest of this chapter provides a list of the six major activities involved in such a pilot trial.

### Standardization of European Videotex

The Commission of the European Communities is not represented as such in the international standardization organizations. Although it cannot intervene directly in the discussions on coding and videotex display standards, the Commission can no doubt play a significant rôle in this domain. Standardization is urgently needed so that videotex centres might be able to communicate with one another, and to be accessed by any videotex terminal in any European country. The Commission should therefore carry out whatever actions it can in order to rapidly reach an agreement on standards.

### Definition and Development of European Videotex Terminals

A European videotex terminal should have the following features:

- It should be designed in conformity with a common European videotex standard. (In the meantime, the CEC might find it worthwhile to make use of multi-standard terminals for test purposes.)
- It must incorporate a character generator capable of displaying correct versions of all the national languages of the nine members of the EEC.
- A complete alphanumeric keyboard should be attached to the terminal.

An editing terminal should be defined and developed together with the user terminal.

### Conversion of Diane Data Bases into Videotex Form

We recommend that two different kinds of actions be carried out, one leading to the immediate creation of videotex data bases, and the other preparing tools for future conversions.

### Creation of Videotex Data Bases on Diane Hosts

In the near future, videotex data bases might be created on some Euronet Diane hosts from the information contained in existing STI files. This could be performed manually using editing terminals. Among the various data bases that could be treated in this manner, the CEC might decide to include one of its own, e.g., Chronos.

## Development of the Means to Convert STI Data Bases into Videotex Form

Looking ahead, the Commission should launch feasibility studies in order to specify the sort of tools suitable for converting the documentary data bases of Euronet Diane into videotex data bases. These could be located either in the host computers themselves or in videotex centres, both private and public:

### - General conversion package

We recommend that the feasibility of portable software be examined. This could be adapted to the different videotex standards and to the various characteristics of the hosts. This software would be designed primarily to handle bulk updates, with as little human intervention as possible.

### - Semi-automatic conversational editing system

Demonstrations have already been provided of the feasibility of an intelligent terminal connected to a Euronet Diane host and then to a videotex centre. A dialogue would take place with the editor concerning the preparation of pages and the inclusion of display attributes. We think it would be a good idea to start to study the specifications and the development problems of such a videotex editing system, based upon European hardware. This system would be most suitable for the creation of small data bases requiring a lot of human intervention for the introduction of display features.

## Creation of a European Videotex Centre

The best way for the CEC to bring videotex problems to the surface, and to search for appropriate solutions, would be to actually set up its own videotex centre on one of the Commission's computers. This centre could concentrate on data that is of particular interest to EEC members. For example, the very first experiment could be based on a directory that describes all the information offered by Euronet Diane hosts.

## Development of a Family of Interface Equipments

The Euronet network might well be used to access videotex services and to interconnect videotex centres. Several types of interface equipment, between the videotex services and Euronet, have been defined. The pilot trial could start out by testing the Videotex Access Unit, and then the European Videotex Gateway.

We feel that the specifications and development of these two pieces of equipment should be started as soon as possible, on common bases. The hardware could be of limited proportions compared to the equipment required for a generalized European videotex system, but the functions would remain the same.

Specifications and standards are required for three sorts of interchange protocols:

- access protocols to videotex services (common command set),
- protocols between interface equipments, and
- protocols between these equipments and videotex centres.

We feel that the study of these protocols should start as soon as possible. The feasibility of the development of the interface function between videotex terminals and the Euronet Diane host data bases should be studied.

A study should be carried out in order to evaluate the interest of access to videotex services by means of Teletype-compatible terminals. If the results were positive, then the specifications of the equipment required for the adaptation of such terminals should be prepared.

A feasibility study might also be carried out concerning the conversion of simple commands, keyable by means of a numeric keypad, into the more complicated commands needed for the retrieval of data that is not organized in a tree structure.

#### Development of Terminals that Can Access Both Videotex and Euronet Diane Services

Euronet Diane users may prefer to employ the same terminal for retrieving information from STI data bases and from videotex services. Small firms and professional people such as doctors and lawyers might also be interested in the approach of adapting a standard TV set for this purpose. A microprocessor used as a videotex decoder might also handle the functions of driving the PAD facility (setting the related parameters and automatically identifying the user). A simple TV add-on device could be designed containing a keyboard, a processor and a modem. It is probably worthwhile looking into the possibility of compact packaging including all the equipment in the keyboard. One standard TV socket must be defined on a European basis in order to connect TV peripheral equipment of this type.

In other words, this final chapter of the VIDEOTEX/EURONET COMPATIBILITY STUDY is intended to demonstrate that the CEC, if it so desired, could certainly carry out a number of specific operations that might very well play a most important rôle in the development of this new European branch of communications technology. The recommendations concern primarily the standardization, then the implementation, of the three kinds of entities involved: terminals, data bases and transmission facilities. All activities, therefore, are to be performed in parallel. Standardization efforts, above all, must be intensified immediately. On the other hand, the development of conversion tools and interface equipment - which cannot be carried out on a very short time-scale - should start as soon as possible.

## **LECTURE: Videotex Development outside the Community**

*Mr. R. Woolfe, Butler, Cox & Partners,  
London*

For the next twenty minutes, I am going to talk about videotex development outside the Community. I am a partner with Butler Cox and Partners, an independent management consultancy specializing in information technology. Our involvement with interactive videotex began when, with help from the British Post Office, we arranged the first public conferences on Prestel. During 1978 we conducted a multi-client study in the US on videotex's potential there, and in the next few weeks we will complete a similar study on videotex and its potential impact in Europe. Already, over seventy major companies sponsor these studies. We also undertake assignments for individual clients in this area. I am in charge of our videotex activities, so I have been responsible for these projects. Because we take great care to preserve our independence, we owe allegiance to no one. Over videotex we can be entirely objective and unprejudiced.

There is a great deal of videotex activity outside the EEC. I'll talk first about non-EEC European countries, then the USA, then Canada, then Japan and finally developments in some other countries. My focus will be on two-way videotex services, primarily using the telephone, though two-way cable is an alternative delivery medium.

There are three main categories of videotex service. First: public services, which - because of their potential scale - are of most interest to PTTs in Europe. Second: closed user group services, available to private subscribers either as part of a public service or through an independent private operator. And third: in-house services established by businesses for their own private use. Although my main focus will be on the development of public services, I shall also allude to the two other categories.

A review, then, of the status of videotex developments... first in non-EEC European countries.

In Austria, little activity so far. But recently, ITT Austria has been considering arranging the installation of several test terminals - one for the University of Graz and others to be located elsewhere for demonstrations. The plan is for them to be connected both to Prestel in London, and to Bildschirmtext in Darmstadt.

Next, Finland. This country is experimenting with its own



videotex service called Telset, which started a year's trial in 1978. It has been developed by Sanoma (Finland's largest newspaper publishing group) in conjunction with Nokia (manufacturer of terminals) and the Helsinki Telephone Company, which has 600,000 telephones in the Helsinki area. Telset is based on the Prestel standard, though the software has been specially written for the computer, a DEC PDP 11/34. The aim is to develop a Telset centre able to support 200 simultaneous users. A nationwide service is expected to require a network of regional and local centres. Conceivably, a public service along these lines could begin in the early 1980s.

Next, Norway. Here the videotex climate is neutral. The PTT sent out invitations to industry to tender for a trial service about the end of 1978. The plan was for the trial to begin in the summer of 1979, but the likelihood is that it will be delayed probably by several months. About 10,000 information frames will be made available to information providers, with about 100 user terminals distributed amongst a representative selection of users. A state committee, set up during 1978 to report on the media, has been embroiled with satellites and copyright issues arising from videograms... and, before the spring of 1979, it had shown little interest in videotex. The PTT expects that, when a public service finally gets started, it will provide switching centres and some of the data bases.

In Sweden, low profile videotex experiments are continuing. As a government commission continues to debate the ramifications of videotex, the PTT is keeping a low profile and using the breathing space to develop its DataVision software. DataVision runs on a Data General Nova computer, and includes alphanumeric keyword searching in its protocols - regarded as essential for business users. At this time the PTT is only concerned with the business market, both for political reasons and because it sees this market as most promising. A field trial with about fifteen participating information providers is just getting started. Depending on its success, and the findings of the government commission, the next step could be to install another system to carry out a public market trial... conceivably in 1980/81, with up to a thousand users. The PTT feels that a full public service developed from this could be a possibility by 1983, though it remains sceptical about the residential market prospects.

Next, Switzerland. After protracted negotiations with the British Post Office, the Swiss PTT announced this spring that it had concluded an agreement to purchase the Prestel software and know-how to run on a GEC computer. This will be installed in Berne at the end of September. (That's the plan, anyway.) A private pilot trial will start before the end of the year, and the plan is to follow it with a public market trial in 1980. The PTT's tentative name for its service is "telephone Bildschirmtext". By the end of May 1979, there

were 21 members forming an IP's association representing the following industry sectors: computing, travel, mail order, pharmaceutical, publishing, manufacturing and financial. The Swiss PTT's intention is to follow the trial with a public service in 1982 or 1983.

Finally, Spain. At the end of 1978, Fundesco (a non-profit making communication research organization, 50% government owned and 50% privately held, but controlled by the PTT) was negotiating the purchase of Prestel. An agreement was expected about now.

So much for the non-EEC European countries. What about the USA? Here there is a great deal of interest amongst private sector industry.

First on this list is Insac/GTE. Insac was formed in 1977 by Britain's National Enterprise Board to market British computer systems and software overseas. Since early 1978, its US subsidiary has been out to sell Prestel in the US. It announced a successful agreement with GTE, the ten billion dollar n° 2 telecommunications company in the US, earlier this month. GTE is expected to start a limited service this summer, concentrating on the business market initially and expanding later into the residential market.

The Dow Jones/Apple system permits users of Apple 2 personal computers to connect to the Dow Jones news retrieval service via Tymnet, providing users with relatively cheap access to the quotation portion of DJS's extensive data base of financial information. Apple 2 computers now cost \$1000 and upwards, depending on the peripheral equipment. Many Apple users plug into their home TVs as their display device.

Green Thumb is a telephone videotex system proposed by the National Weather Service and the US Department of Agriculture. Its purpose is to provide highly specific information at low cost to farmers. The plan is to start a small test with about 200 farmers this year in two Kentucky counties, expanding later to around 200 counties and then to a full national service. Altogether there are some 3000 counties in the US, and perhaps two million farmers who should be able to afford the system. Green Thumb is interesting because, unlike Prestel and unlike Antiope, it relies on a "dump and disconnect" mode of operation - receiving a burst of information and disconnecting for subsequent retrieval from local memory. For well-defined applications, this is very suitable. It minimizes the number of ports needed at the data base and the time-metered connexion. But a disadvantage is that the amount of information which can be held in local memory is limited. Information currently planned includes weather, agricultural recommendations, market prices and home economics.

Next, Knight-Ridder Viewtron. Knight-Ridder is a major

newspaper and TV station group based in Miami, Florida. It publishes 34 daily newspapers. In April it announced a commitment of \$1.3 million in the next two years to develop a service aimed primarily at the residential market. Information will include local and national news, weather, sports results, local information, education courses, product ratings, local movie and restaurant and theatre schedules. A pilot trial is planned to start in early 1980 with up to 200 families participating in the Miami area.

Alpex 900 is the name of another telephone videotex system announced in May by the Alpex computer corporation of Danbury. It is aimed primarily at publishers of newsletters and other time-sensitive periodicals, for whom the regular mails and even delivery by special air couriers may be too slow. Alpex claims to be developing a large-scale data base containing publishers' information.

Other telephone systems include "The Source" information utility offered by TCA, the Telecomputing Corporation of America: a subsidiary of the Digital Broadcasting Corporation of Maclean, Virginia... which, as some of you know, has been experimenting with an interesting one-way sideband radio system. TCA's plan is to offer over 2000 programs to personal computer users, including text editing, income tax preparation packages, and several hundred games. An airline ticketing service, UPI news wire service, and electronic mail services are also on the agenda. TCA will employ a new off-peak rate which Telenet plans for high night-time and weekend usage. The plan is for "The Source" to be priced at \$2.75 per connect hour. The service is aimed at users of popular personal computers, either with their own CRT terminals, or able to be plugged in to a regular TV. To operate "The Source", each user needs an acoustic coupler to receive and transmit signals through the telephone network.

Apart from these telephone videotex systems, there is a great deal of interest in two-way cable systems. Several cable companies are planning to introduce limited services in the near future. One expects to launch a service this year to demonstrate and develop banking services including bill paying and shopping from home.

This list is not by any means complete. During the next several months, there is no doubt at all that new systems and services will be added to it.

Canada, too, is very active. The development which has attracted most interest to date has been the Department of Communications Telidon system designed for use with either the telephone or two-way cable. A field trial is expected to begin before the end of the year. Unlike Prestel and Antiope, which are character generator systems, Telidon is a frame-store system. Data is not stored in the computer data base in a form ready for mapping directly on to terminal

displays, but as a set of descriptive language statements. Consequently, any terminal able to decode the language can present a display. The display resolution becomes a function of the terminal's resolution capability, and not of the data. So it opens the door to any future changes in TV set resolution, without jeopardizing the data base. Telidon's superior image capability has been well demonstrated. But, for a full comparison to be made with character generator systems, an analysis of the costs involved is needed - not only terminal costs, but also the costs of data base maintenance and transmission.

Next on the list is Bell Canada's Vista. The hardware for Vista has been developed by Bell Northern Research under contract to Bell Canada, using a modified Prestel specification. The plan is for a pilot project in 1979 to lead to a larger market study in 1980. Two other companies are involved: Southam Press, a Toronto-based newspaper chain and publishing house; and Torstar, also based in Toronto, which publishes the "Toronto Star" and has other communication interests. Both companies will provide information for use in the project.

Next, what about Japan? Japan has her own videotex experiments under way. Not surprisingly, she is also closely watching the events in Europe and North America. Naturally, Japanese companies are sponsors of our studies. Let us look at four Japanese experiments.

The first is Captains, which stands for Character and Pattern Telephone Access Information Network System. Demonstrated in 1978, Captains is being developed by the Ministry of Posts and Telecommunications in conjunction with Nippon Telegraph and Telephone (NTT). The present trials are planned to enlarge into a full-scale market experiment in the Tokyo metropolitan area beginning next year. Like Prestel and Antiope, Captains requires adapted TVs with keypads to be attached to the regular telephone network. But Captains uses a frame-store display, like Telidon, in order to handle Kanji, Hiragana and Katakana characters. Characters are generated at the Captains centre, and the full array of pattern bits representing the display - all the picture element bits - are transmitted down the line. Here it differs from Prestel and Antiope, which transmit coded data to be formed into characters and graphics by a character generator in each TV terminal. Captains needs more bits to be transmitted per frame - 64 kilobits compared with around 10 - and a correspondingly larger, so more expensive, memory in each TV. But it can construct images with correspondingly finer resolution.

Next is VRS: the video response system also developed by NTT. VRS has been under development since 1973, and NTT has been using it internally for over two years. It has announced plans to sell it to individual companies and to establish a

public service before 1983. Conceptually, it is different to Captains. VRS provides still and moving video quality pictures, as well as audio. It requires users to have a special high capacity one-way telephone line in addition to a regular two-way line. The special line is fitted with repeaters to permit an abnormally high bandwidth around 4.5 megahertz. It is plugged into the antenna socket of an unmodified TV. Users can select still videotex information frames by entering codes on their regular telephone push-button dials. The data for each frame is transmitted back as a video picture, repeating at a frequency of thirty times per second.

Next is CCIS, which is an experimental two-way cable service in a Tokyo suburb called Tama New Town. CCIS, which stands for Coaxial Cable Information Service, has been under trial since early 1976 with a representative residential population. In the first phase, now completed, 500 householders tested ten different cable services. One of these, the "still picture request service", was an interactive videotex-like service. Information was stored in 6000 microfilms at the head end. Viewers requesting access through their keypads were able to receive a frame of their choice in about four seconds. The type of information ranged from notices of community activities to recipes. In the current phase, the number of services has been reduced from ten to six. The "still picture service" is one of the six... though the least popular of those selected for continuation.

Finally, Hi-OVIS. This is another two-way cable experiment, characterized by the use of optical fibres. Started about a year ago, Hi-OVIS is being tested by around 170 households in the new town of Higashi-Ikoma. Like CCIS, Hi-OVIS offers a number of services, one of which is a still picture videotex-like service, with information such as regional news, traffic information, railway timetables, local events and a guide to shopping bargains.

I have talked briefly about videotex developments in the non-EEC European countries, the USA, Canada and Japan. But world interest does not stop there. Hong Kong has agreed to start an experiment using the British Post Office's Prestel system. Singapore is very interested. So are Australia and Russia, and I have no doubt that other countries will join them.

In Europe, the emphasis so far is on public videotex services operated by the PTTs, with the ultimate prospects of large-scale markets. Elsewhere, different systems are being developed by the private sector aimed initially at special-interest business groups, defined geographical areas and cable subscribing communities. The time has come when both public and private sector business interests believe that videotex can be an economic proposition. So we have a scene with different markets being targetted, together with a

lack of standardization resulting from differences in technology and timing in this nascent industry. And underlying that, a lack of certainty about the real nature and extent of the market-place, particularly in the residential area.

But the potential of the videotex concept remains a strong one. So it is no wonder that a variety of trials and implementation plans are emerging all over the world. It is clear that the Community has no monopoly on videotex, and that future policies must be framed against an understanding of worldwide developments.

## DISCUSSION – Session No. 1

Mr C. de JONG (Netherlands): I would like to describe the network architecture adopted by the Netherlands. First, I would like to point out that our videotex system will be using our packet-switched data-transmission network, with the X25 protocol. Second, we are also developing - not only for videotex users - a switched system with special numbers... and one of these numbers provides the possibility of getting connected to videotex.

Mr R. MALIK (United Kingdom): I'm a journalist, and I seem to be the only genuine user here! I first wish to make some comments on the Japanese situation. I've recently been in Japan looking at this. I understand from Mr Robin SCOTT that the name "Teletext" is still in use in England. "Videotex" is a new name, and I will stick to "Teletext"... because I gather that the Oxford English Dictionary has in fact accepted the term! We are in danger of getting ourselves into considering a situation which is concerned with information retrieval. This arises from the past of the computer history, as opposed to looking at the systems in a much broader context. The Japanese have not made that approach. Listening to Roger WOOLFE, one had the impression that here was a specific set of systems developed one after the other. They weren't! There is some historical train of technological development following technological development, but the Japanese developments begin with these initial documents: the study on the information society, of the late '60s... in the great euphoric days when everybody thought that there was no recession coming, and that all this was going to fly! We've all seen these studies. I have piles of them in my office... all done in the States, as well. The Japanese have been struggling with this problem for ten years. But they haven't just been struggling with Teletext or videotex. They've been looking at that as just a narrow subset of what it is they want to do. The Japanese situation, one must remember, is not a situation that is steered by one authority, in one particular direction. There has been intense competition in Japan between the multi-sponsored organizations on one side and the PTT-sponsored on the other. Anything one can do, the other tries to do better. That's part of the history. It's interesting that they are now reconciled in the success of Captains. Now, I have in fact played with Captains on the experimental set. They say to me, very cynically, that the Japanese, like Frenchmen, will never accept Captains because the minimum delay time is about 15 seconds. We are now

talking about broadcast Teletext, and this is of course a great problem. People in Japan are talking about 30 seconds, when playing with Captains... but they do have a successor. The trials of the successor started in Fujitsu in January. They are developing a thing called Davins: data and video information network services. And this is very much a Viewdata-like system. It will have character generators in the sets. They are talking in terms of 256 K to start, because of course they have Japanese characters to take care of. I believe we are talking of 1 K bits to cope with... I'm never sure which character is which... but anyway the most complex of the Japanese characters. It's interesting that Davins is going to be run by the same people who are running Captains. It will have the same information providers. There are about 120 IPs already working with Captains. If you look at the history of the transmission media that the Japanese have been using, they have first of all tried normal television, then cable television, then optical fibre transmission. They are looking at optical fibre transmission very seriously. They think there's a lot of rebuilding to be done in Japan: optical fibres can go in everywhere. But now you look at the services. They include all sorts of video services ranging from closed-circuit television through to film services (this is one aspect of it: the entertainment aspect). There are the communication services and there are the Viewdata-like services. It is the communications services which interest me. I think if we tend to look at this in terms of information retrieval, we are making a very bad mistake. I have just written a book with Sam Fedida, the so-called inventor of Viewdata in England, which comes out in autumn. We are saying effectively that information retrieval... yes, it's well understood by people in the computer business... yes, it's well understood by people in publishing... Information retrieval may be a planet-sized market, but communications is going to be a galaxy-wide market!

Mr J. KANZOW (Germany): I would like to add some information to the first paper presented. It was said that a very important point was the approval of a European standard. Well, I think this standard has been achieved for the CEPT countries. There was a meeting last week in London at which a common proposal was worked out, and this proposal is to form the basis of the future work of the CEPT countries within the CCITT. The second piece of information I wish to add is the concept being adopted by the German Bildschirmtext. It didn't emerge very clearly that the transmission paths which are used between the central body for Bildschirmtext and externally, as in France, is a public data-transmission network... and that is on the basis of packet switching. We are going to implement this on the X25 basis in our field study next year.

Mrs C. SCHWARTZ (France): I would like to mention another point on which agreement was reached, not just at a European



level, but at a world level. It concerns the procedure of access to videotex. This was mentioned as being lacking. Very recently, an initial list of procedures to be used by subscribers was drawn up within the CCITT, and it is now the basis for further work done for all countries. Now, of course, it has to be completed and extended because, at the present time, it basically applies to the tree structure, and this isn't the only structure used. But there is a sound working basis in this area, that we should respect.

Mr H. DRUECK (Germany): I want to very briefly add some information to the reports concerning the situation in the Federal Republic of Germany, concerning radio. At the radio exhibition in Berlin in 1977, as will be the case in autumn 1979, the German radio systems ARD and ZDF presented to the public an experiment with what we call "Videotext". And that is the German system based on the Teletext system from the United Kingdom. This system will be implemented in the whole of the Federal Republic as of 1980, and will continue to be presented for public experiments. This is a Teletext broadcast system. It will be limited to a small amount of information during the initial stages, but the German radio networks consider that it could be a considerable complement to the general network services. And that is why we are going to be using it, legally speaking. I wanted to add this information to what has been said because, on the basis of the available documentation, you simply mentioned the experiment on Bildschirmtext, which will be taking place around Düsseldorf as of 1980. But, as I said, the German radio networks are also going to start with an experiment, as of 1980, throughout the whole of the Federal Republic of Germany.

Mr O. TCHERNIAK (France): I would just like to make a couple of points on the first statement when it comes to the experience with 250 thousand subscribers in a French region. This is planned for 1983, but it will actually begin in 1981. So it will immediately follow the initial pilot trials, aimed at testing the service, which will cover three thousand subscribers. The second point is a clarification concerning the systems used for Télétel when it comes to the integration or otherwise of decoders and modems. The version described here employed an external attachment. But this is not a final choice from the French Administration. It's the one used at the present time, but it's probably not the final choice. As for the broadcast system, these things will certainly be integrated into the terminal.

Mr M. ROETTER (A.D. Little, Paris): I would like to say that, certainly, the point that Mr MALIK has made, regarding the fact that videotex must be viewed within a very broad context, seems to be shared by the Commission. Both PA and ourselves have made precisely this point, that videotex is merely one development amongst many others in terms of technology and services which need to be taken account of.

What is interesting is that it is one of the few developments in which, up to now, the Europeans appear to have taken somewhat of a lead. Now it is likely that this lead will be lost unless there are some quite firm policy decisions and actions taken, particularly in the realm of regulations which were designed to conform to a technological situation which was valid in the 1930s but is no longer true! And I hope that we shall be able to discuss these in more detail in the future. In regard to the situation in Japan, it is - as Mr MALIK has said - very important to recognize the long-term commitment which the Japanese have to developing various kinds of telecommunications-based services: social services, medical information services, and so forth... as well as what is traditionally understood by information retrieval. It is also interesting to note that, up to now, the Japanese have been relatively backward in the development of such services. One of the principal reasons, I think (this is a personal judgment, not an official one), has been the very cautious and conservative rôle of NTT which, for example, for a long time, delayed the introduction of time-sharing services, and has attempted as far as possible to keep such services for itself, to the detriment of more entrepreneur-oriented companies. I think that in this respect, too, we have something to learn from the Japanese. When we attempt to see where they may be going, instead of looking at them (as Mr MALIK has pointed out quite correctly) as a single monolith moving clearly in one direction, we realize that there's a very complex interplay of social and political, as well as technological, forces.

Mr M. CREMER (CIDST): I'm here in my capacity as the chairman of the CIDST - the Committee for Information and Documentation on Science and Technology, mentioned by Mr VERNIMB this morning - and that's why I would like to make a few general comments on the relationship between Euronet and videotex. In the Télésystèmes document, they speak a lot about Euronet, and they talk a lot about the links between Euronet and videotex. Now Euronet, first and foremost, was invented and developed for the very specific purposes of scientific and technical information. Now we saw very soon that Euronet would also be very useful for so-called "third traffic"... in other words, for the transfer of data and facts and news outside the restricted area of scientific and technical information. The document from Télésystèmes contains some proposals, including the idea that data bases created for the Euronet system might be connected to videotex services. Now, I honestly don't know whether scientific and technical information really has a primary rôle to play with the implementation of videotex... because, if I look at the second document here, they talk about all kinds of things, but they don't really talk about scientific and technical information as such. And sometimes I have the impression that we, on the scientific and technical information side, create the illusion that we - and we only - are the main users of this technology along with other

communications technologies. In the Télésystèmes document I was, of course, extremely interested to see that certain proposals were made, namely, that data bases linked up to a host computer in the Euronet context might be put into liaison with videotex. But what exactly does that mean? Will these data bases simply include titles and bibliographical information, summaries of original publications and similar data? How can the users of such secondary information have access to the primary documents? Another proposal might be that, in the future, instead of simply storing the secondary data in the host computers, we store the full texts themselves. That would put us into contact with the major problems that we already have today with publishers. It's not just a question of an increasing need for copies of original documents, but all of a sudden we find ourselves in a totally different situation, i.e., instead of books, instead of printed magazines, etc., we want the full texts... And this would mean a very big change in the nature of publishing as such. Are such matters being considered at present? And, if so, what sort of timetable exists? In our discussions with publishers concerning Euronet, we have been saying that what is involved is simply a speeding-up of the ordering of documents via libraries. We never thought that publications could be replaced by other technologies. We are certainly very interested in this question... but we are also rather concerned when we look at the economic, scientific and technical implications.

Mr R.K. APPLEYARD: I would like to add one comment about your difficulty of principle about scientific and technical information. This is a class of information which no longer interests very many people. I prefer to go the other way and to say that any information which is systematically stocked in an orderly manner, by definition, is scientific and technical information. Copyright and such matters will certainly be one of our major problems in this whole area.

Mr H.J. BREIDENSTEIN (Germany): I am a publisher from Frankfurt, and I am extremely grateful to Dr CREMER for drawing attention to the links between Euronet and videotex. And I am grateful, too, for his touching on the implications for the publisher or the information provider. In the near future, though, we do not consider the situation to be so acute. The immediate problem of photocopies would appear to be more urgent, because here you have a printed copy that costs less. We see a shift between cheap reproduction of printed matter along with expensive distribution, as at present, and a future situation of cheap distribution but expensive storage of information. This shift will come, but not all that soon. We have a breathing space, but we don't deny that there's a long-term problem which must be tackled, and that's why I would like to ask you the following question: Would it be possible, during this conference, to look into the legal sphere in which these different systems must be incorporated? Publishers, of course, are interested

in having a system such as Bildschirmtext. But we would like this to be covered properly at a legal level, because we think that publishers will actually provide a large part of the edited information.

Mr R.K. APPLEYARD: I do agree with you very much. We will have to come to grips with the legal side of the problem, both at the copyright and at the post-office regulatory levels, and I hope we'll have time to discuss these matters. As for your other remarks, it seems to me that storage is becoming cheaper because computer memory is becoming cheaper. But, I must say that, if I could only devise a really good, simple, cheap printout, then I would leave my job at the Commission and go into business! It seems to me that that's what is missing. For example, in the French PTT, it will be fine when they take away the directories and replace them by a little gadget... but you won't be able to throw it into the car and take it with you when you go shopping. So, it will have some disadvantages unless there's a little printout.

Mr J.F. PEDERSEN (Denmark): As far as the legal questions mentioned by Mr BREIDENSTEIN are concerned, I would like to point out that in Denmark, a year and a half ago, the prime minister appointed a special committee to look into this subject, in the case of both the broadcast and interactive versions of videotex. And this committee also studied the social and financial and general impact on society of these new systems. The committee includes representatives from the PTT, from the private telephone companies, from the publishers and the press, and from various industries as well as union representatives. I think it's important to define what legal actions are to be taken before embarking on large-scale changes in these fields.

Mr J.M. HARPER (United Kingdom): There's one general point I would like to make, which might affect the logic of the discussion both today and tomorrow. I would like to go back to what Mr MALIK said originally when he put emphasis on the communications side of this general family of services which we are discussing, as distinct from the information retrieval side. I was just a little worried by the implication that the post offices were not perhaps sufficiently aware of the communications possibilities of these services. And I thought it might be helpful if I just said that my own analysis is that there are two major categories in this field. The first is information retrieval... and I was very interested to hear mention of program retrieval services as well as information retrieval, because it seems to me that program borrowing is an important part of the whole situation. But I think, on the one hand, there are what I would generally call information retrieval services. And on the other hand, there are communication services: in other words, a terminal communicating with another terminal, as distinct from a terminal communicating with a central computer. The problems of these two fields overlap to some extent, but these

problems are considerable in both cases, and very complicated. I would hope that, during this conference, the focus will be primarily on the information retrieval side... because we are "in a different ballpark" (if you'll forgive me for using that American expression) as soon as we start talking about communication services.

Mr R.K. APPLEYARD: Thank you very much. I think that, before we go on, I would like to disagree with you a little bit. It seems to me that, in your own country, anyone who has talked with the Prestel group can see that they are getting moved into a more and more interactive state. The pressure is increasing towards the interactive, towards the transactional... Now, when do you stop calling it that, and call it a message? After all, if a piece of data is put in by somebody, through no matter what chain of intermediate computers, and then taken out by somebody else at a terminal, it's a message, it's a communication. I don't believe there's a finite line separating the two phenomena, and I don't believe the rest of us will be happy if the post offices tried to draw such a finite line, no matter where they draw it. I'm sticking my neck out and exaggerating... but for the purpose of discussion anyway.

Mr J.M. HARPER: I understand exactly what you are getting at. All I want to say as an answer, at the moment, is that the British Post Office is involved, of course, both in the information retrieval and in the communication categories. My remarks concerned, above all, the logic of handling the subject here and now in Luxembourg. My own analysis is that the problems in the two categories are rather different. I'm not blowing the trumpet of the PTTs when I say that they probably understand much better the problems of the communication services. I don't intend to take up your time describing all the work being done in this field. I merely think that, if you are to get maximum value out of the next twenty-four hours, your focus should be on the information retrieval side.

Mr A.C. NICHOLAS (CIDST): Euronet, as Dr CREMER has pointed out, will be going into operation this autumn. It is a PTT innovation for Europe. Moreover, Euronet has been so successful that the PTTs have actually taken over our name, and we have been obliged to call upon the name "Diane" for the Community part of the activity. I would now like to reply both to Mr HARPER and to Dr CREMER. I see no clash between the use of high-speed networks like Euronet, on the one hand, and videotex on the other. As far as Euronet is concerned, one is talking about high-speed retrieval of data stored in very large and complex data bases, composed of thousands of megabytes... and you need intermediaries who understand the structure of these data bases in great depth. As for videotex, I suggest we really ought to focus our attention on information for the end user, i.e., for direct applications. That is a vast area which should be of interest to us all. I

came to this meeting, on the plane from London, with a colleague who is in our ministry of agriculture in England. He was concerned with advice to farmers. And I found, to my delight, that they are thinking very hard about the question: How do you advise farmers on what sprays to use on their crops, right now, immediately? That's the sort of factual information which is needed on a very large scale... together with social information, taxation information, etc... and I suggest that we should be looking at the types of information that might be stored, along with the problem of making certain that the information does in fact flow as it should. I would also like to reply to our publisher colleague from Germany, Mr BREIDENSTEIN, because I think the situation is becoming clearer. It's beginning to look as if the medium will be provided by the PTTs, and the publishers will provide the information and will own the copyright, meaning that revenue will be able to reach the copyright owners. This looks good, and right. But I agree that we ought to discuss this topic.

Mr R.K. APPLEYARD: If there are no further comments at this point of the discussion, I would like to go back to one subject that intrigued me in the second presentation. It looked as though there is quite a lot of emphasis in the United States on services where the transmission part limits itself very strictly in the services given to classes of people who have personal computers. Things may be different in the States from in Europe, but I suppose that it's the extreme end of the situation already mentioned: first you put everything inside the TV set, then you put the modem outside, or you put the modem and the decoder outside... and the extreme end of that spectrum is where you simply provide very little in the transmission net, and most of the on-the-spot work is done by a personal computer. Is this kind of a market likely to develop in Europe, a little behind the States? Are personal computers coming along so quickly that they will turn out to be a real competitor with respect to "classical" videotex?

Mr H.D. SCHOLZ (Pactel, Frankfurt): Personal computers are a very big subject, and I believe that they should be included in the same domain as the TV sets, keyboards and computers encountered in videotex.

Mr R. BARNES (MWS Services, London): This afternoon, I shall be speaking on this very same subject, regarding the use of personal computers in a European context, not in an American context. It seems to me that you have already, in a personal computer, all the elements that you would find, or need to find, in any sophisticated interactive videotex terminal. That would include, obviously, an alphanumeric keyboard along with memory and display capabilities. We already have as evidence, in Europe, people such as Luxor in Sweden who have developed personal computers with the idea of the output formatting being Viewdata-compatible. I don't feel that this

is a competitive element, but more an element of expansion offered to the small user, small businessman or individual who wants to multi-functionalize his product directly.

Mrs C. SCHWARTZ: The range of possibilities for the processing of information at the terminal level is perhaps one of the things that will be clarified by current experiments dealing with transactional, rather than pure information retrieval, systems.

Mr J. KANZOW: I think that the questions which have been discussed so far, including the question of the actual use of the personal or domestic computer, are basically marginal questions which spring from the tremendous breakthrough brought about by videotex. In the Federal Republic of Germany, we are more and more interested in what I would call the semi-professional applications of videotex. Insurance firms and their agents, for example, have never been able to access large data bases directly, simply because the networks necessary for that were too expensive. Via videotex, on the other hand, we can imagine inexpensive data communications systems that might be used by many groups of people for whom the high costs of data communications used to be prohibitive. In addition, videotex systems and their standards will surely influence many general standardization questions that have arisen in the field of data communications. And this should put an end to some of the typical problems we have encountered. For example, the problem of one computer not being able to talk to another computer because they don't use the same language standards. I think that the question of access to Euronet and to scientific data bases is merely one aspect of an overall problem. Today we can achieve something that was impossible up until now, in that scientists can access data bases by means of a low-cost terminal located right in their offices and laboratories. As for Mr HARPER's question, I would say that we are talking essentially about communications systems. The questions of information retrieval are important at a development and structural level, for "filling in holes" in our informational frameworks. But the basic problem is to invent a system which would enable us to have access, in a very simple manner, to ALL human knowledge. We are currently performing the spade-work for developments of which the final objectives are not yet visible. Data bases and personal computers can both, of course, be used in this domain. Future developments will, I believe, be fascinating... but it's unlikely that any single observer can grasp everything that is likely to take place.

Mr R. SCOTT (United Kingdom): My comments arise partly from Rex MALIK's intervention, and also from personal thoughts and from our own broadcasting experience at the BBC in the use of Teletext... as we continue to call it. Ceefax, which was the pioneer in the United Kingdom, followed by Oracle, has now had some four years of experience with the public. It is

perhaps interesting that less than twenty thousand actual Teletext sets are in use in the United Kingdom, which is of course considerably less than the original market forecast. I have no doubt that that will grow. I remember early discussions with our friends at the Post Office, when it seemed to us that the developments of Viewdata - as it was then called - would depend to some extent on the success of broadcast Teletext... or broadcast videotex as it is now being called. This, curiously enough, may not happen... and I would suggest that what we are seeing is the gradual emergence of two types of information transmitted in this very abbreviated form. One must remember that the actual transmission of information on to a television screen, whether it is a domestic screen (with its attention divided between programmes and text, which, in the context of a family, is quite a problem for a start) or whether it is received on a separate special monitor of a different kind (which, I suggest, may be the future of developments like Prestel), provides a very summary kind of information. You are receiving less than one hundred words per page. To actually look at video displays in the form of text is also quite a tiring process. It does not in fact provide you with anything like the same amount of information, or the same ease of reading and assimilation, as does the printed page. This is not to seek to diminish the value of broadcast Teletext, or indeed the other Post Office associated systems... or indeed of the information system which you are setting up in Europe: Euronet. But I want to try (for my own purposes, in a sense, speaking and thinking aloud) to separate information retrieval in a pure scientific form, which is really a guide to publications, from the situation in which you obtain the actual publications themselves. I suggest that Euronet will probably function in the first manner. It will indicate where you can find the information in the full form in which you require it... but it will not provide you with the full information. One might consider that broadcast Teletext is "printed radio", and it is printed radio in a very summarized form. It is the headlines, the guide-lines, the signposts towards the fuller information you require. And because of the time taken to retrieve information, unlike the Prestel system (where, of course, you have to dial the number and so forth... so quite a lot is involved in that), even on a hundred pages, where you might have anything up to twenty-five seconds in retrieval time delay, all this adds up to a system which is actually quite basic, very useful to a wide public, with enormous general information possibilities, whether it's the weather, the stock market, etc. But, as was pointed out recently, even the idea of providing a complete list of all the films that can be seen in the cinemas of a major capital is more than what most Teletext or Prestel systems can cope with. So, do not let us be dazzled by the prospects of a universal information provider. What we are concerned with is a series of signposts and a series of abbreviated information guides. And eventually I would hope that we would be talking, not only of



simply looking at monitors, but about very cheap systems of hard-copy printing. This possibility already exists (for we use systems of hard-copy printing of Ceefax information within the BBC), and there is no doubt at all that this can be developed in a quite simple form using a cheap paper base to do it. We are looking towards a system which would provide the farmer, for example, at breakfast time, with a series of copies - hard copies, very cheaply produced - of all the information that concerns him... so that he has it, he can put it in his wallet, he can take it to the market, he can read it while he's having a beer... That is the future of the system, to my mind, the real future, together with much more extended facsimile systems which provide the equivalent of newspapers to people who really want the full information and not just the signposts. Now, I don't wish to pour cold water on the system... but I would simply like to say that we should not be dazzled by it in any way. And let us remember that, because of the very restricted information contained on that screen, you will never get a complete service.

Mr R.K. APPLEYARD: If I understand correctly then, Mr SCOTT, you are a potential customer for the machine I would like to invent: a cheap hard-copier using toilet paper!

Mr J.M. HARPER: May I just make one further remark which, again, concerns the logic of our discussions. It seems to me that what I'm listening to, today, is to some extent a discussion among my potential customers. At the bottom, we PTTs are interested in traffic on our networks. And we don't really mind where it comes from... to be quite blunt about it. Our concern is to encourage the use of all these services in one form or another. Now, it seems to me, Mr Chairman, that your problem is not so much one of network layouts (and I don't think the technical discussion of network layouts should enter into our preoccupations here), it is not perhaps a problem of standards, but much more a question of the identification of the markets, and of the organization of the markets and of the legal questions that come up in the organization of those markets. The point which is coming through over and over again in this discussion is that we have these technical possibilities, and, certainly, from the point of view of transmitting these kinds of data, we have the possibility to do it, and we also have the systems to do it... What all of you seem to be debating, in one form or another, is the problem of organizing how you exploit these technological facilities. I would suggest, Mr Chairman, that this is the theme we should return to. Regarding this as a marketing discussion, may I make one final point? I think there are three basic market segments. First, there is the market segment of the simple use of these systems, which is exactly what my colleague Robin SCOTT just described: the simple domestic situation, the simple farming situation... Secondly, there's the market segment of the business use of these systems, which is familiar to many of us, and which certainly involves large amounts of information retrieval:

probably computing, probably distributed processing... And thirdly, there are scientific applications, which certainly lead into the problems of displaying full text, described earlier. But it seems to me, again, that unless you make that basic market sectorization, you stand in the risk of continuous confusion in these discussions.

Mr R.K. APPLEBYARD: May I ask a question? The interactive deal corresponding to buying at a distance, or negotiating with one's stockbroker at a distance... Is this a separate market, or is this under one of your headings already?

Mr J.M. HARPER: This is my personal conception, and not necessarily a British Post Office conception. I would say that the simple interactive transaction - e.g., buying a car over Prestel or Viewdata using a credit card number - seems to me clearly directed to the residential market, to the public market. There is obviously a more complex kind of business transaction, which would be typically a large firm discussing its share-holding portfolio with its stockbroker, which must belong naturally to my middle market sector, where the marketing considerations would be different, and quite possibly the technical and standards considerations would also be different.

Mr H.J. BREIDENSTEIN: I would like to find a middle-of-the-road position between what Mr HARPER and Mr SCOTT have been saying, and indeed develop the points made by Mr KANZOW. Of course there are different markets here which are in fact simply different areas of application. In the final analysis, and I think Mr HARPER said this very clearly at the end of his statement, this is a form of telecommunications... as Mr KANZOW also said. And the screen is merely one apparatus among other possible machines. The use of such a telecom device will be divided among various markets, but, to our mind, it doesn't vary technically in any basic way. The interests of users vary from one application area to another, but not the basic technical considerations.

Mr R. MALIK: Our colleague from the British Post Office referred to the interactive market. Now, all I want to point out (at the risk of turning this into an intra-country dispute) is that, as soon as you allow interactive processes into the discussion here, you are henceforth talking about communications.

Mr R.K. APPLEBYARD: Before closing the discussion for lunch, I would like to underline the importance of European standards with the following story. <Mr APPLEBYARD tells a story about a baby who concludes that he must be a boy because he is wearing blue shoes.> Now, the point of my story is that, for Belgian rather than British listeners, it would have to be the other way round, i.e., pink shoes... because the "coding" is reversed. So, we really do need European standards.

## LECTURE: Videotex Market in the Community

*Mr. H.D. Scholz, Pactel, Frankfurt*

This morning we have heard about the current developments of videotex inside and outside the European Community. The question, then, is: What are going to be the likely consequences of these developments for the Community? We have been asked to assess the potential market of videotex systems, and I want to summarize this study, and place particular emphasis on the results we have come up with within the context of those issues that can be influenced by policy, i.e., things that are going to influence the potential itself.

The market for videotex sets and services in the Community is potentially huge, and should be comparable at the end of the forecast period - i.e., in about 1995 - with the combined present-day revenues of the telecommunications carriers and the publishing sectors. Paradoxically, by the end of this forecast period, videotex in its present form - as it is presently conceived, and discussed here today - will have disappeared. However, it will have left behind a number of important innovations, and these will relate in general to information systems development, and they will encompass developments in the residential market, opening up a mass market of electronic systems and services there, accelerating electronic publishing, and accelerating the very essential standardization and regulatory development that has already been mentioned briefly in the discussions this morning.

Videotex is therefore important, in our view, not so much as a system that - as I just said - will have a rather limited life in its present form, but rather as an organizing concept. And this organizing concept lies at the junction of telecommunications, of broadcasting, of computing and of publishing. There is going to be a catalytic significance to these systems which is quite distinct from the particular videotex projects that are currently under way. These projects have been briefly mentioned here this morning. One of the things we see is that the paper specifications that go hand in hand with this development work are constantly being upgraded. The reason for the limited lifetime of videotex as a system, we see in the present rather confused multiplicity of participants: PTTs, manufacturers and information providers, all trying to come in from a different angle and participate in this systems development.

PTTs favour integration of videotex with the telephone

network, and they try to exploit their current network capacity. The manufacturers see videotex as a replacement for colour television, and favour its integration with broadcast television and Teletext. They would like to see lots of sets sold, and look to the domestic sector for this. The difference between the PTTs and the television manufacturers can be seen in fig. 1. Information providers and publishers see videotex as a means of reaching large markets, and they tend to favour as much integration with existing systems as possible. Publishers - and particularly newspaper publishers - tend to have a more negative attitude towards videotex, but it is likely that they too will want to have their products integrated with videotex, rather than seeing them replaced or eroded by videotex developing as a separate product. Trade unions will, by and large, try to resist the replacement of existing products and services. Broadcasting organizations, in turn, see videotex as complementary, and they will see it as something that is not all that competitive to what they are doing. This is true even in Germany, where the legal position may require an artificial division between them, with the effect that videotex would be regarded as press, and subject to federal legislation, while Teletext would be regarded as broadcasting, and subject to Länder regulation.

In view of these differing attitudes and goals, there will be inevitable competitive evolution. Since videotex offers no compelling centralizing concept, videotex projects will tend to diffuse into the broad stream of ongoing information systems development. Even if we consider the market only in terms of the present basic systems, there are still major uncertainties about future development. These relate to assumptions about a range of factors that are shown in fig. 2. These include the questions of set price and set penetration, the usage price and the volume, the functions available, the technical standards, the suppliers of hardware, the suppliers of services, and regulations. We have developed three scenarios based on assumptions about these factors. Essentially, the scenarios can be thought of as ranging from high set cost and low usage cost, with slow development, to low set cost and low usage cost (high usage), with fast development. The most likely, or reference, scenario lies in between these two extremes.

The forecasts based on these scenarios, for the numbers of installed sets, are shown in fig. 3. For the reference scenario, we forecast for the Community, in 1995, over thirty million sets installed. As can be seen in fig. 4(a), we predict that videotex will give rise, in 1995, to PTT revenues of 2,000 million European Units of Account (EUAs) in 1979 values. Usage revenues accruing to information providers and service operators would amount to approximately 2,500 million EUAs a year. Set supplier revenues would be 4,000 million EUAs/year. And - see fig. 4(b) - there would be something like 35,000 million transactions annually.

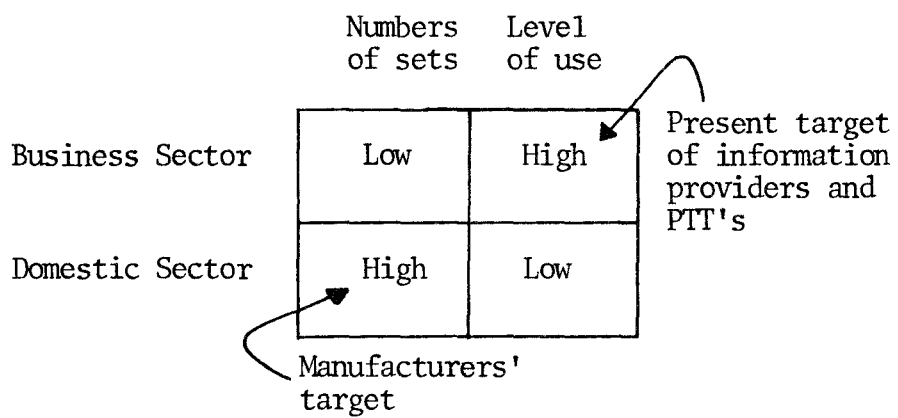

Fig. 1 Potential conflict among the three major parties to videotex

	MINUS	REFERENCE	PLUS
Set price	high	medium	low
Set penetration	low, partial	50%	tending to 100%
Usage price	low	low	low-high
Usage volume	low	medium	high
Eurochip standard	no	yes	yes
Set suppliers	some TV manufacturers, some sets	all TV manufacturers, all sets	all TV manufacturers plus newcomers
Information, service suppliers	defensive publishers	major publishers, service suppliers, few newcomers	mass entry publishers, service suppliers, plus new suppliers
Functions	information retrieval	information retrieval plus some new	information retrieval plus many new functions
Regulations	not applicable or restraining	neutral	enabling, facilitating

Fig. 2 Assumptions for each of the three scenarios

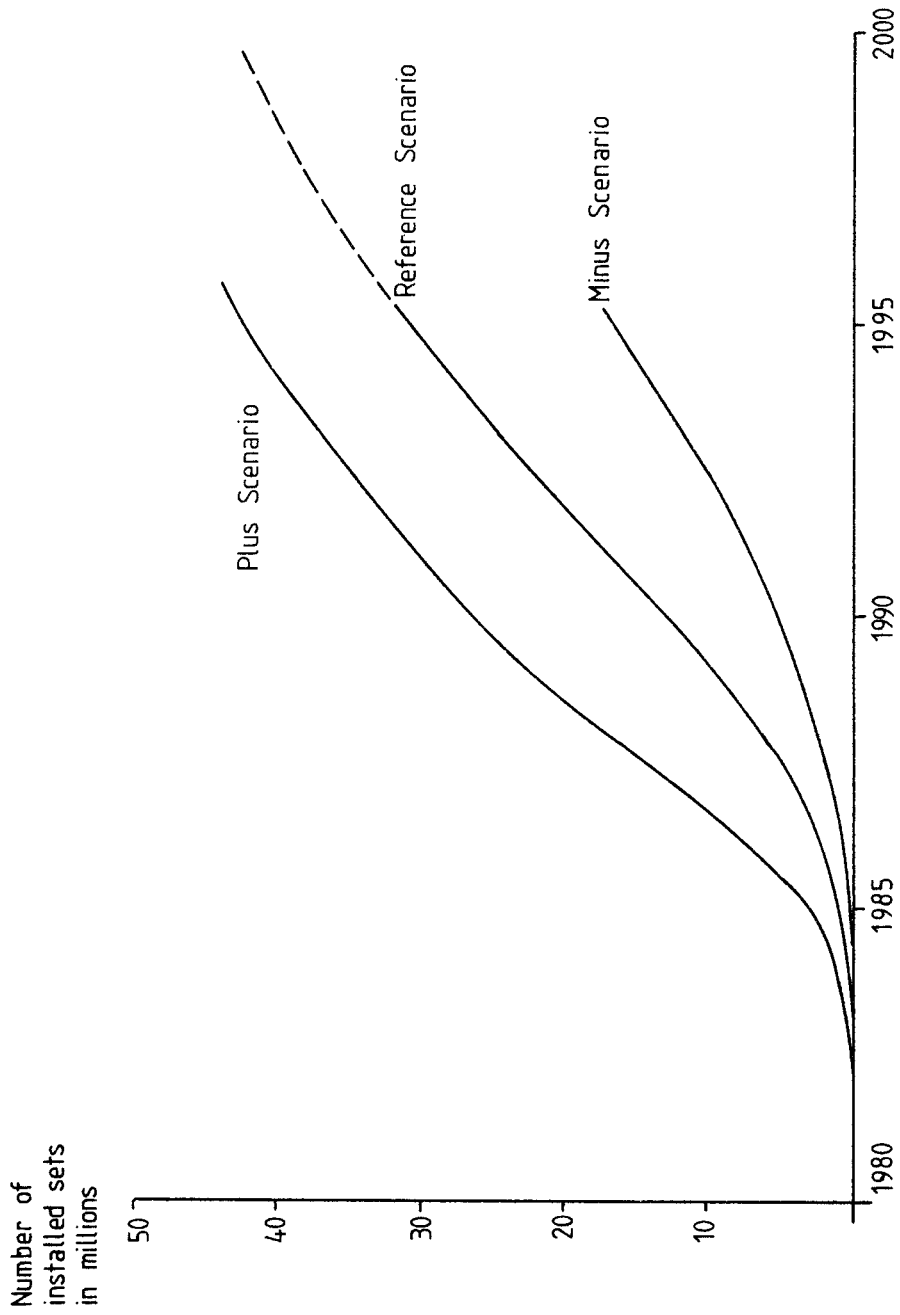

Fig. 3 Videotex sets installed in the EEC

<b>(a)</b>	<u>Scenario</u>	<u>Sets</u> *	<u>Line Costs</u> *	<u>Transaction Costs</u> *	<u>Total</u> *
	Minus	3,600	650	450	4,700
	Reference	4,000	2,000	2,500	8,500
	Plus	1,000	5,500	10,000	16,500

\* in millions of European Units of Account (EUAs) a year

<b>(b)</b>	<u>Scenario</u>	<u>Sets</u>	<u>Transactions</u>
	Minus	18 million	8,400 million
	Reference	32 million	35,000 million
	Plus	43 million	120,000 million

<b>(c)</b>	<u>Scenario</u>	<u>Usage revenue per set installed in 1995</u>
	Minus	61 EUA/year
	Reference	140 EUA/year
	Plus	360 EUA/year

Fig. 4 Forecast figures for 1995



The development of the usage of such systems is shown in fig. 5. It should be noted - see fig. 4(c) - that, in the plus scenario, usage revenues become very large, actually exceeding those for set suppliers quite considerably.

The three scenarios - especially the reference scenario - seem entirely plausible when compared with the current reference data shown in fig. 6. For instance, in 1977, the revenue total for Community PTTs is seventeen thousand million EUAs. This is for a total of about sixty thousand million calls, with an installed base of eighty-five million main stations. The average revenue per station is two hundred EUAs per year, at an average transaction rate - i.e., the number of calls - of two per day. Then, for the information suppliers and the set suppliers, television sales for 1977 were of the order of four thousand five hundred EUAs, and the average time spent in watching TV per day was one and a half hours. Book, newspaper and magazine sales in the Community amounted, in that year, to something like nine and a half million EUAs, and computer sales to three thousand five hundred EUAs.

It is worth remarking that the information supply requirements and opportunities arising from videotex appear, on the basis of the figures we have just discussed, to be several orders of magnitude greater than, for example, those to be expected from the operation of Euronet-Diane.

I should now like to consider the distribution of the market for videotex in the Community. We see the market distribution between countries as very much a function of the states of national videotex development, and a function of the penetration of telephone and colour television. This puts the UK, the Netherlands, Germany and France ahead of the rest, and finds Italy lagging the field. The greatest differences between countries appear to lie on the supply side. We can speak of a relatively uniform Community market being serviced by a number of different national supply strategies, especially with regard to overall systems architecture. This could create difficulties at a Community level with regard to compatibility and interworking of different systems.

Within countries, we expect videotex developments in the home and in the office to diverge to some extent. The main reason for this is that videotex is likely to represent the first major penetration into the home of "digital intelligence"... whereas, in the office, such "intelligence" already exists in the form of word processors, data terminals, small business computers and so on.

We see, in fig. 7, a summary of the domestic and business market sectors. In percentage terms - i.e., the percent of households, or the percent of white-collar workers -, our research indicates a relatively high penetration in the business sector. However, in terms of the number of sets

Fig. 5 Videotex usage in the EEC

Annual transactions  
on public videotex  
systems  $\times 10^9$

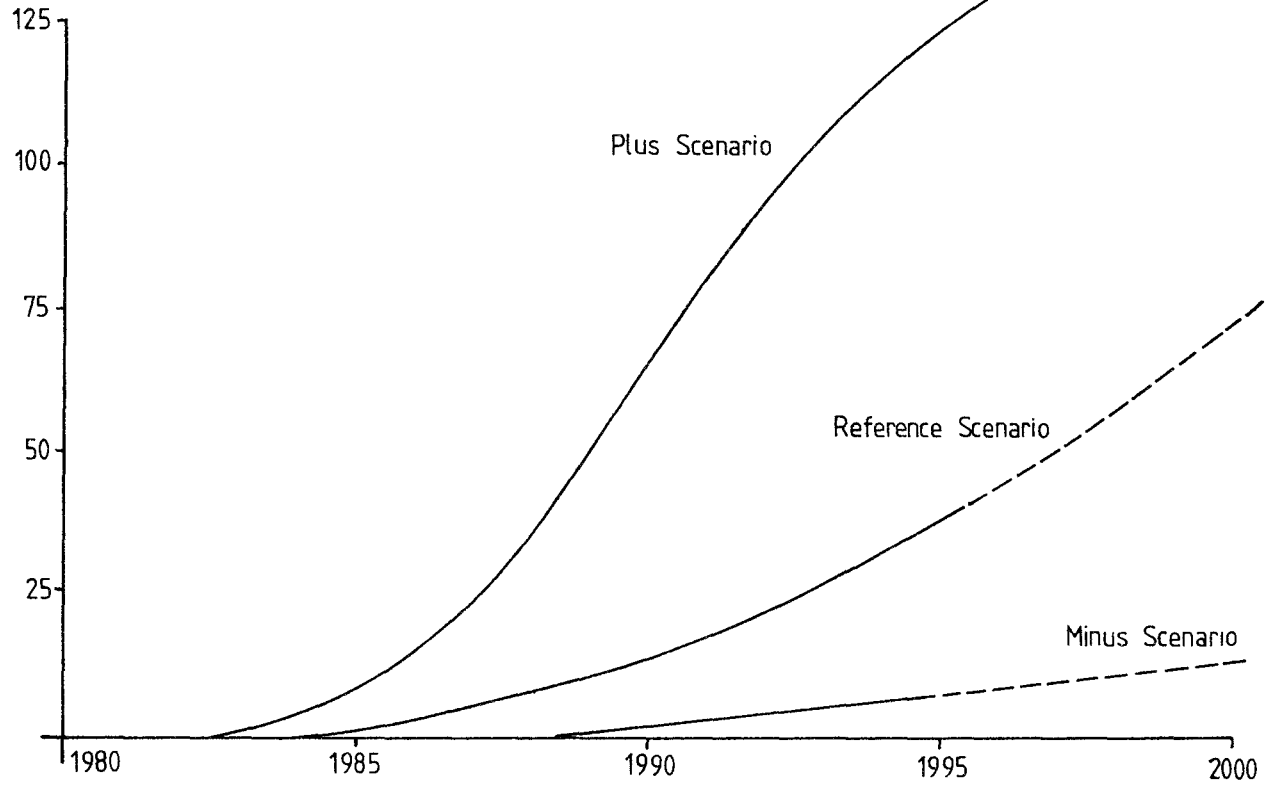

Community PTT revenues from telecommunications (1977)	17,000 million EUA
Number of telephone calls (1977)	60,000 million
Number of telephone stations (1977)	85 million
Average revenue per station (1977)	200 EUA
Average calls per station/day (1977)	2
Community TV sales (1977)	4,500 million EUA
Average time watching TV/day (1977)	90 minutes
Community book sales (1977)	3,500 million EUA
Community newspaper and magazine sales (1977)	6,000 million EUA
Community computer sales (1977)	3,500 million EUA

Fig. 6 Current reference data

	1985		1995	
	% Penetration	Number of sets (millions)	% Penetration	Number of sets (millions)
Domestic	5 +	4.25	30 +	25.5
Business	9 +	0.3	40 +	1.4

Fig. 7 Expected penetration and number of sets in the domestic and business sectors (from personal interviews)

installed, the domestic sector is likely to be very much more important. You will now appreciate why the set manufacturers are so interested in the domestic market.

A point I made earlier related to the differing objectives of the parties involved in videotex. The business sector is likely to have relatively few sets, but will generate a lot of usage.

I should now like to turn to what we believe are four very important factors influencing the success, or otherwise, of videotex in the Community. First of all, we believe that there should be what we call, for brevity, a Eurochip decoder standard. We further believe that effective innovation is very important for achieving what we have called the "plus scenario". Then there are the ratios between capital and operating costs. And finally there is what we call "regulatory facilitation"...

Given a Community-wide standard, we expect a mixed market for videotex to develop; without such a standard, we will be left with what we call the "minus scenario": a limited national market, high prices for sets, low usage, low revenues and depressed market entry. Under the term "effective innovation", we should mention, above all, both the supply of sets and the services that go with these systems. The large and powerful existing market forces, especially TV manufacturers and publishers, will seek to control developments in this new market to fit in with their existing financial and product planning. Innovation, of course, is more than invention. It includes everything from initial development, product design, engineering to production standards, and full-scale production, to marketing and product support. Europe has invented videotex, but, unless it takes the lead in these other aspects of innovation as well, it will come under heavy competition from more economically aggressive countries such as the United States and Japan. If this happens, Europe will not reap the main benefits of videotex, even though it is a European invention. This, of course, would not be the first time something like this has happened...

The capital to operating costs ratio is determined partly by the factors we have already discussed, and it will help to shape the character of videotex. Our minus and our reference scenarios assume relatively large capital outlay to acquire a videotex set, with relatively low-cost services. The plus scenario is based on the assumption of a very low-priced set.

Finally, there is the question of regulatory facilitation. If a mass market for videotex is to develop, our research strongly suggests that it must not be restricted artificially by legal, political or regulatory factors.

In conclusion, we see a large market for videotex in the

Community, given the intelligent harmonization of efforts of the member countries and the various parties involved, especially the PTTs, television manufacturers and publishers. The Commission's previous experience with Euronet suggests that we can be optimistic about this. The challenge may be greater in the case of videotex, but so are the benefits. These benefits can be quantified by the differences between the three scenarios I have mentioned. This means, by the end of the forecast period, between the minus scenario and the reference scenario, an annual value of four thousand million EUAs, and between the minus scenario and the plus scenario, a difference of twelve thousand million units of account, per year. This represents at least five hundred thousand direct jobs, neglecting any multiplier effects. What are the actions, then, required at a Community level to reap these potential benefits? To facilitate the development and the exploitation of the possibilities offered by videotex in the Community, we make the following recommendations to the Community on this subject.

First of all, one must promote standards activity towards a Community-wide Eurochip decoder. Secondly, there must be innovation in both the hardware and information supply industries, in order to secure the benefits of the most favourable (plus) scenario. Thirdly: the question of establishing a Community centre for the study of regulatory policies and practices. And, in fact, Mr McGREGOR ROSS is going to talk a little bit more about the more technical aspects of that innovation question.

In summary, then, we say that there is potentially a very large market for videotex. If Europe cannot satisfy this market, then other countries will... Videotex will be absorbed into a more general trend by the end of the forecast period. And, if videotex is to be a success for Europe, it is essential that all the various parties involved work together... despite - or, I should say, because of - their differences in immediate objectives. The Commission is in a unique position, in Europe, to assist in the intelligent harmonization of efforts, and has an important rôle to play in this regard. We have indicated some of the ways, we believe, the Commission can execute that rôle effectively.

## TEXT: Videotex Market and Display Study

Summarized extracts from the study report:

*PA Management Consultants, Frankfurt*

### GENERAL RESULTS OF THE PA STUDY

General results arising from the study as a whole are presented below under the headings:

- videotex
- videotex and technology
- videotex and systems
- videotex and applications
- three scenarios for development
- mass market
- home/business
- internal/external adaptation
- country differences in supply/demand.

### Videotex

By the end of the forecast period, videotex - as presently conceived - will have disappeared, leaving behind a number of important contributions to general information systems development. These include:

- opening up the mass residential market to electronic systems and services;
- acceleration of mass electronic publishing; and
- acceleration of essential standards and regulatory development.

These contributions are of such potential significance to the social and economic life of the Community that the Commission should be closely involved with videotex in this formative period.

The reason for the importance of videotex lies in its catalytic rôle as an organising concept at the junction of telecommunications, computing, broadcasting and publishing. This catalytic significance is quite distinct from the actual videotex developments under way in a number of Community, and other, countries.

There will be inevitable and competitive evolution, and since videotex offers no compelling centralising concept, videotex projects will tend to diffuse into the broad stream of on-going information systems development, e.g., including online information retrieval, word processing, database management

systems, message switching, small business systems, computer conferencing.

Demand for the services that videotex projects are designed to offer will persist, although it will increasingly be met in other ways. Consequently, as time passes, it is likely that systems will look less and less like today's projects.

The major alternative to this view of the future is the possibility that the PTTs will seek to enlarge their monopoly to cover videotex as a new tarified service. This is presently unlikely, but cannot be entirely ruled out.

The multi-sectoral implications of videotex throw into relief the fact that there is virtually no present Commission machinery appropriate for representing, coordinating or directing the whole range of activities that videotex is now bringing together.

### Videotex and Technology

The technology employed by current videotex projects is not the only one available. This is true particularly for both the public switched telephone network, and the terminal. In considering future videotex development, it is therefore important not to lose sight of complementary or competing technologies.

Information can be distributed to the terminal by discrete means (e.g., magnetic cards or floppy disks) in those cases where frequent updating is not required. Very high information densities are possible. Loadable games are a step in this direction. The telephone network is then only necessary for very current material, or for updating the discrete medium.

Broadcast media have already developed Teletext. With the possibility of dedicated TV channels, hard copy, and packet radio developments, sets can be removed from the telephone network and carried freely around. Broadcast media are particularly competitive for the most popular current items (e.g., sports results, news headlines) where simultaneous access via the public switched telephone network would pose severe network loading problems.

Broadband switched distribution may become possible with coaxial cables or optical fibres, in the mid-1980s. This will have immediate effects on the volume of information flow, the resolution of graphics displays, local storage requirements, etc., although first applications will be for trunk rather than local transmission.

The data processing industry, with its entry into office systems, has created systems of much greater power than videotex, backed by very capable industrial organizations. They will



not sit by while videotex takes over their potential market. Videotex may spur a competitive step on their part which will completely change the future situation.

At the terminal level, falling costs of processing and storage will lead to increased local intelligence, and flat screens will change the ground-rules on graphics through digital addressing.

At the media level, electronic digital technology is leading to the compatible management and manipulation of information of all types, whether voice, data, text, graphics or video. Videotex will be rapidly obsoleted if it remains with its limited text and crude graphics.

### Videotex and Systems

Function and capability in a videotex system must be distributed in some way between the host computer, the communications network and the terminal. This is the question of systems architecture, solutions to which will strongly influence longer-term developments.

The main architectural components in videotex are:

- the terminal operated by the user;
- a communications network linking the user to the videotex host computer(s) via local concentrators or network access points;
- videotex host computers serving terminals with interactive videotex transactions from stored data bases; and
- other computers (third party service suppliers), accessible from videotex terminals, e.g., offering message switching, mail order purchases, remote data processing, medical diagnosis, computer assisted instruction, and other interactive services.

At the present moment, there is no Community consensus on systems architecture, which may make inter-working between countries difficult at a network level. In the UK, the Post Office sees the rôle of the network as an access medium to its own network of computers. The French will give the network a more important rôle in switching the user to the appropriate host. In Germany, access will be to a network of Bildschirmtext computers, with the user possibly being passed through to third party service suppliers for part of the on-line dialogue.

It is important to understand the consequences of different systems architectures before there is large-scale Community investment in incompatible videotex implementations.

Of particular interest at the present stage of development is the distribution of intelligence in the system. Increases in microprocessor power, with corresponding decreases in size and cost, offer a range of systems strategies. Thus, instead of the basic Prestel or Antiope systems with hard-wired character sets and no intelligence, we have the possibility of:

- downloading character sets to the terminal (soft alphabets);
- downloading programs to the terminal (tele-software); and
- downloading coded pictures to the terminal, as in the Telidon alpha-geometric approach.

At the same time, additional functions can be implemented on the retrieval computer, e.g., more complex frame selection, computations, frame generation (such as graphs from tabulated data), etc.

### Videotex and Applications

The main application foreseen in the short term is information retrieval. In the long term, the mail-order type of remote shopping becomes important. Messages are not considered to represent an important application, because videotex is not seen as a competitive medium for their use.

### Three Scenarios for Development

(The editors have not included the two pages of the PA text on this subject, because Mr SCHOLZ has already described these scenarios in his lecture.)

### Mass Market

We expect that a mass market will develop, given a Community wide standard. In the reference scenario, this will be a "tidy" market as TV manufacturers eventually convert totally to videotex sets in the later part of the forecast period. The minus scenario will lead to a large but inactive market, whereas the plus scenario will lead to a faster, less tidy, more dynamic mass market than the reference scenario.

### Home/Business

In the home, videotex will become the potential nucleus of a home information or systems centre, just as we have the present home audio entertainment centre structured around the hi-fi amplifier and controls.

In the office, videotex will be assimilated into emerging office systems structures as a peripheral item, representing both a cheap colour display for in-company uses, as well as a

means of access to external public information media in the technical, financial, news and general business areas.

Despite these differences, the two areas of development are linked by the fact that economies of scale in the home market will have important consequences for costs in the business sector (although not necessarily for prices charged to the user).

#### Internal/External Adaptation

As long as present TV manufacturers control the market, there will be a strong tendency for most sets to be supplied as built-in, internally adapted, fully packaged units. External adaptors will open the market to newcomers, with a base in intelligent systems technology, and whether or not this happens depends on the extent of innovation that can be encouraged, i.e., the extent to which the plus scenario can be realized.

#### Country Differences in Supply/Demand

On the evidence available to us, the greatest country differences lie in supply, not in demand. One can speak, therefore, of a relatively uniform Community market being serviced by a number of different national supply strategies. There are some time differentials as a result of the timing of national projects, but the greatest differences lie in approaches to overall systems architecture. While it is not necessary that national supply strategies be the same, this is clearly a potential problem area in relation to compatibility and inter-connexion or interworking at a Community level.

#### SPECIFIC RESULTS OF THE PA STUDY

In addition to the general results above, each separate area of research and analysis has produced its own specific results. These are summarized below under the these headings:

- graphics and display
- user perceptions
- development of supply
- market forecast
- policy analysis.

#### Graphics and Display

- (a) First generation videotex text and graphics are limited, graphics much more so than text. For this reason, the next major improvement may well be an improvement in graphics. In graphics, Antiope is somewhat more powerful than Prestel, but non-Community developments in Canada and Japan are more powerful than either.

- (b) Much of the experience of print technology is unsuited to screen-based displays because of the difference in respect of light, being absorbed in the former and emitted in the latter.
- (c) Colour is of very great importance, more so than graphic quality.
- (d) Initial information providers have a strong print bias in the layout and logical organization of their material, although there is some innovation.
- (e) Information access of videotex is simple in principle, but primitive, and can be frustrating and ineffective.
- (f) Research in the scientific and technical information field has focussed on combinatorial access to information elements, e.g., through Boolean keyword approaches. Videotex is organized on linear, sequential access lines, and is utterly different.
- (g) Printed indexes and directories appear important in augmenting the system-based indexes.

#### User Perceptions

- (a) Videotex is seen primarily as an information retrieval system particularly suitable for the home but with some applications in other areas, including business, government and education. There is relatively little enthusiasm for other facilities that videotex might offer, such as messages or computation.
- (b) Videotex seems likely to have a fairly high priority in homes over the next few years, but only if it is available in the form of colour sets. Black and white have fairly low priority, about the same as that of TV games. It is likely to have a fairly low priority, compared with the acquisition of other items, in business, government and education.
- (c) Potential government and business users see more opportunity for their organizations as information providers to home users, than as users of other providers' information.
- (d) Motives for becoming an information provider are generally conservative to defensive, e.g., to promote a good image, to avoid falling behind competitors, rather than financially aggressive, i.e., to make money.
- (e) Potential business and government users see little advantage in setting up in-house systems rather than the types of computer systems already in use, although there might be some advantages in cheap terminals.

- (f) Home users are interested in the system, but actual experience with Prestel was often frustrating when information could not be found, or did not even exist, in spite of indications given at higher levels in the tree that it was available. Success and failure in searching videotex are more extreme than in the case of STI, and users are consequently less tolerant.
- (g) Videotex is felt to be suitable for educational applications both in the home and in school, especially for 12-year olds and above, including adults. However, fundamental problems in education are not technological, and so it will not provide instant benefits without a period of exploration and learning on the part of the educational community.
- (h) Competition in the home for the television set between television watching and videotex, and for the telephone between telephone conversation and videotex may be a problem.

#### Development of Supply

These results differ in some details from those of the previous section, since most of the respondents here are associated with videotex on the supply side, rather than as potential users. The differences may reflect their greater knowledge, or simply a partisan optimism.

- (a) Information retrieval is seen as the most important videotex application.
- (b) In addition, by the mid-1980s, most respondents believe that other functions such as response recording, remote shopping, computer assisted instruction, messages, tele-software and computing services will be commonplace as videotex functions.
- (c) International standardization is seen as very important in order to permit a Community mass market.
- (d) The most important parties in videotex development today are the PTTs, television set manufacturers and information providers. By 1990, information providers and users will be the most important, together with advertisers.
- (e) Videotex is seen as most like on-line information retrieval services today (from a number of candidates for similarity). By 1990, it will still be quite like on-line retrieval, and more like newspapers and magazines, but above all it will be most like:
  - electronic mail (thought of as more extensive than simple messages);
  - personal computing; and
  - mail order catalogues... in that order.

- (f) Set penetration in business is expected to be higher than in homes on a percentage basis, although the difference diminishes throughout the forecast period. In numbers, however, the home market is 10-20 times the business market.
- (g) Videotex is not seen as very competitive for a number of applications/purposes studied, nor against a number of alternative media/services.
- (h) While cooperation among the major parties to videotex is essential, a potential conflict of interests is already evident. Set manufacturers would prefer to go for the domestic market, since they get their money from sets without any concern as to whether or not they are used. PTTs and information providers obtain revenue on an as-used basis, and consequently favour the business market, where they believe usage will be higher.

### Market Forecast

Public videotex activity is likely to become large in the course of the period covered by the study, i.e., 1980 to 1995.

(Forecast figures are contained Mr SCHOLZ's lecture.)

Most of the sets will be installed in homes. Usage will be distributed between work, home and education in the approximate ratio of 1:2:1.

These figures change dramatically in the plus scenario, with set-related revenues dropping and usage-related revenues increasing by a factor of almost ten.

If these figures are in fact realized, then videotex will clearly be of the greatest economic, social and industrial significance to Europe.

### Policy Analysis

- (a) Videotex is one of the systems to be supported by the new generation of PTT special-purpose networks, along with other network-supported services. Differing national solutions may lead to network interconnect problems at a Community level.
- (b) Standards are of the greatest importance in realizing a mass market.
- (c) PTT certification procedures are an obstacle to a Community-wide market for set suppliers.
- (d) Information access harmonization and standards are of comparable importance to standards activities in hardware.

- (e) The information supply requirements and opportunities arising from videotex are several orders of magnitude greater than those generated by Euronet.
- (f) In addition to hardware and information suppliers, a new type of organization is becoming important, which spans a number of information-technology sectors.
- (g) Innovation in videotex development is of the very greatest importance, and will determine the whole character and health of Community activities in this field. The major parties presently involved will oppose true innovation in order to protect their more basic interests.
- (h) Videotex will affect employment in the Community, with the opportunity of employment gains from 25,000 jobs in 1995, in the most likely scenario, to over 1.000.000 jobs in the plus, or innovative, scenario.
- (i) Regulatory issues related to videotex will be among the most complex and intricate ever faced by the parties concerned. However, this is only going to be a problem for achieving the plus scenario, since regulation will probably have little effect on the reference scenario.
- (j) Videotex is well suited to major applications projects, to act as a stimulus for development at the Community level.
- (k) Videotex pricing is dominated by exploratory investment-oriented activity at the present moment, and it will be years before anything like a true market develops. Tariff structures are not yet defined.
- (l) Videotex will probably serve language groups pretty much as they have been served up till now by printed materials, i.e., it should not increase language discrimination.

#### RECOMMENDATIONS OF THE PA STUDY

Recommendations arising from our study are presented below, roughly in descending order of importance:

- standards
- innovation
- regulation
- industry strength
- graphics and display
- information access and organization
- applications projects
- multilingualism
- miscellaneous.

Under each heading, policy-level recommendations (if any) are stated first, followed by major Commission actions, and finally studies.

### Standards

The Commission should support and encourage all activities that might lead to a Community-wide standard character set, and consequently a "Eurochip" decoder. The proposals made by Data Systems Consultants appear to offer an opportunity of success on this point.

The Commission should explore with Community PTTs the setting up of a network of certification centres for videotex network connect devices, so that in each country, products could be certified for use in all other Community countries. If a network of such centres is too expensive, then a single Community standards laboratory should be set up under Commission auspices to do the same work.

Videotex also requires information-related standards, and the Commission should launch studies to explore the harmonization of information access and organization on videotex.

### Innovation

The Commission should promote innovation in videotex, in both hardware and information supply, as a policy objective of the highest priority.

This can be implemented by a variety of approaches, which include:

- financing through Community sources, e.g., the European Investment Bank, or by working with member state financial institutions;
- major "trigger" projects, designed to exert strong innovative pressures on the supply industries, e.g., by launching a large number of cheap television set adaptors, or by putting up major Commission databases for public videotex access over Euronet;
- studies to inform policy makers and financial planners in the videotex area, covering the hardware and service supply industries, market forecasts, typical rates of return, stability, etc.

### Regulation

The Commission should press for major Community-wide advances in the development of a consistent regulatory framework for the whole area of which videotex is perhaps the most striking example.



We recommend that the Commission establish an institute for the study and development of regulatory frameworks for the information-telecommunications-media field at the Community level. Isolated, single-purpose studies will have no significant effect on a problem area of such complexity.

### Industry Strength

We recommend that the Commission continue its activities in the support of hardware and information supply industries, as well as considering the emergence of multi-sectoral companies such as is happening in the USA, and means to strengthen them.

Policy-making on industrial strategies in the videotex area should be supported by a fact-finding study on the structure of the industry concerned, companies, countries, ownership, technology, profitability, growth, etc.

### Graphics and Display

The Commission should encourage the development of videotex as a Community medium, and not allow the Prestel lead to set de facto standards where they are not in the best interests of the Community as a whole.

The Commission should mount a major programme to outline graphics and display developments over the next five years, linked to technology, setting out a framework of successive generations, with a view to promoting some product release discipline on the part of system developers.

The Commission should launch studies to draw up editorial/graphics guidelines suitable for Community-wide use of videotex, and to study the whole question of screen size and the number and size of characters as between videotex and word processing.

### Information Access and Organization

The Commission should seek to give leadership on a Community-wide basis to information providers, in order to promote effective and harmonized information access and organization on videotex.

A series of studies should be carried out to research information access techniques appropriate to the sequential, linear nature of videotex routing, and more powerful methods if possible, and to show how these may be applied to the different types of information provided on videotex, as well as explaining how the information can be structured most effectively in order to be accessed by these techniques.

Guidelines for information providers and videotex hosts should be drawn up on a Community basis, modelled after the ICSU AB guidelines for Euronet. However, this is only worth a

preliminary study until more national systems become operational.

### Applications Projects

The Commission should launch at least one major applications project, e.g., in the field of education, designed to make a Community-wide impact. This would entail a detailed feasibility study followed by a two year (or more) programme of implementation and evaluation.

### Multilingualism

The Commission should carry out studies on language access and translation in videotex as a new medium, coordinated with the present Action Plan on multilingualism.

### Miscellaneous

The Commission should consider repeating for the Community a number of types of study that have been influential in both the USA and Japan. These include:

- studies on information supply and use indicators, as in the King studies on STI indicators for the NSF;
- studies on employment statistics, as in the Porat studies for the NSF; and
- studies on information flow, as in the Tomita studies in Japan.

These all lead to important policy support information which would go some way towards providing a common statistical basis for policy formulation throughout the Community.

## ISSUES IN SEARCHING (technical section inside the PA study)

Searching videotex, as it stands, is quite unlike the other automated information services that are widespread today, e.g., commercial enquiry systems linked to business data bases, or the scientific and technical information (STI) data bases to be available on Euronet. Three major differences are:

1. The database structure is inherently more varied, and consists of smaller units, or files, than STI data bases. Chemistry and physics abstracts are much more similar than news items and railway timetables. The average size of an IP file is about a million bytes on Prestel at the moment, with a range of a factor of ten larger and smaller. Many STI files are 100 or 1000 times larger than this. There are more files today on the Prestel test service than the number scheduled for Euronet, or available on SDC or Lockheed after many years of operation.
2. The searching system assumes an almost passive host, i.e., selection is made repetitively from a fixed, a priori menu. It is not possible to combine requirements as in Boolean keyword systems (e.g., marketing jobs in the south of France), nor is it possible to qualify the output arithmetically (e.g., the first train after six o'clock).
3. The tree structure is a closed, linked structure. All new additions must be explicitly linked to the tree with absolute page numbers. There is no symbolic cross-referencing, nor is there any provision for the user to search other than in the serial manner presently available.

Although videotex search procedures are much simpler than STI approaches, it has turned out that STI information access research has produced virtually no results of any significance to videotex. This reflects STI obsession with keywords, precision and recall, appropriate to parallel, combinatorial search strategies, as opposed to videotex requirements for sequential, linear access. (There is nothing, actually, to prevent an automatic indexing system from transforming videotex pages into a traditional searchable database, accessible on an active host by keywords, in which case the pages meeting the criteria would be queued for user viewing. Such an approach is used in some computer-controlled microfiche and microfilm systems, although the keywords are separately assigned.)

What this does mean is that there is a whole new research field opened up by videotex, which might be called "serial access systems". The Commission has already begun to develop user aids for Euronet - such as the Common Command language and the standardized descriptions of databases - and is considering more powerful and general access mechanisms such as the Database Selector resulting from research being carried out by Martha Williams in Illinois.

User access to, and satisfaction with, videotex information depends upon the ease and power of access methods. They are presently very limited, in some cases cripplingly so. The Commission should initiate a research and development programme in this area immediately, with due attention being paid to the interests and experience of the whole Community, i.e., not limited to Prestel. Such research might include studies tackling the following questions:

- What natural information structures are identifiable in material being considered for videotex?
- How can these structures be searched by the decimal tree, as described above?
- Is there a case for extending videotex search methods?
- What additional methods can be identified, and what are the indicators enabling us to evaluate their cost and performance?
- What are the human behavioural factors that enter into the various information access strategies?

## LECTURE: Market for Videotex Business Terminals

*Mr. R. Barnes, MWS Services, London*

Let me first introduce myself. I am the European Managing Director for MWS: the Middle West Service Company of Chicago... which is in fact the world's oldest management consulting company, though not very well known in Europe. Our activities are primarily concerned with market studies and economic research in the areas of information processing and consumer electronics. Our origination into this particular study was a result of a previous study we did on computerized products and applications in the home, for the Western European market. This was also a multi-client study purchased by several manufacturers - most of them European, Japanese and American - involved in looking at various applications, products and technologies. One of the largest aspects of that particular study was the work done on Teletext and Viewdata systems - as they were then called -, and, as a result of that study, MWS Services was commissioned to do a subsequent follow-on study on the business market for interactive videotex terminals. At that time, because of the previous work we had done on the domestic market, our feeling was that the business market held a much greater immediate potential, and therefore, if the entire service was to be successful, it needed to be promoted in every possible way, and so the interest of the domestic market would have to be kept at bay until it became feasible.

We looked at the individual technical and economic influences that affect the business videotex market. (See fig. 1.) And we found that several things affect this market both in a positive and in a negative way. Here we have a list of the positive influences, as we see them, in the market. Remember, by the way, that in every aspect of what we are researching here, we are referring only to the business market... although - for obvious reasons - one cannot ignore the domestic market. Electronic-based PABX systems have a very large rôle to play in any business application, if for no other reason than the integration of the four different planes of information processing, that is to say: voice, text, data and image. The next element we see of great importance is the computer services side, bringing lower costs to small information providers who could not otherwise participate in the service. Computer service companies have a very large rôle to play throughout Europe in this aspect, and indeed are taking initiatives in this way. A third area - which is probably not an area very well understood in Europe - is the aspect of facilities management. By this, we really

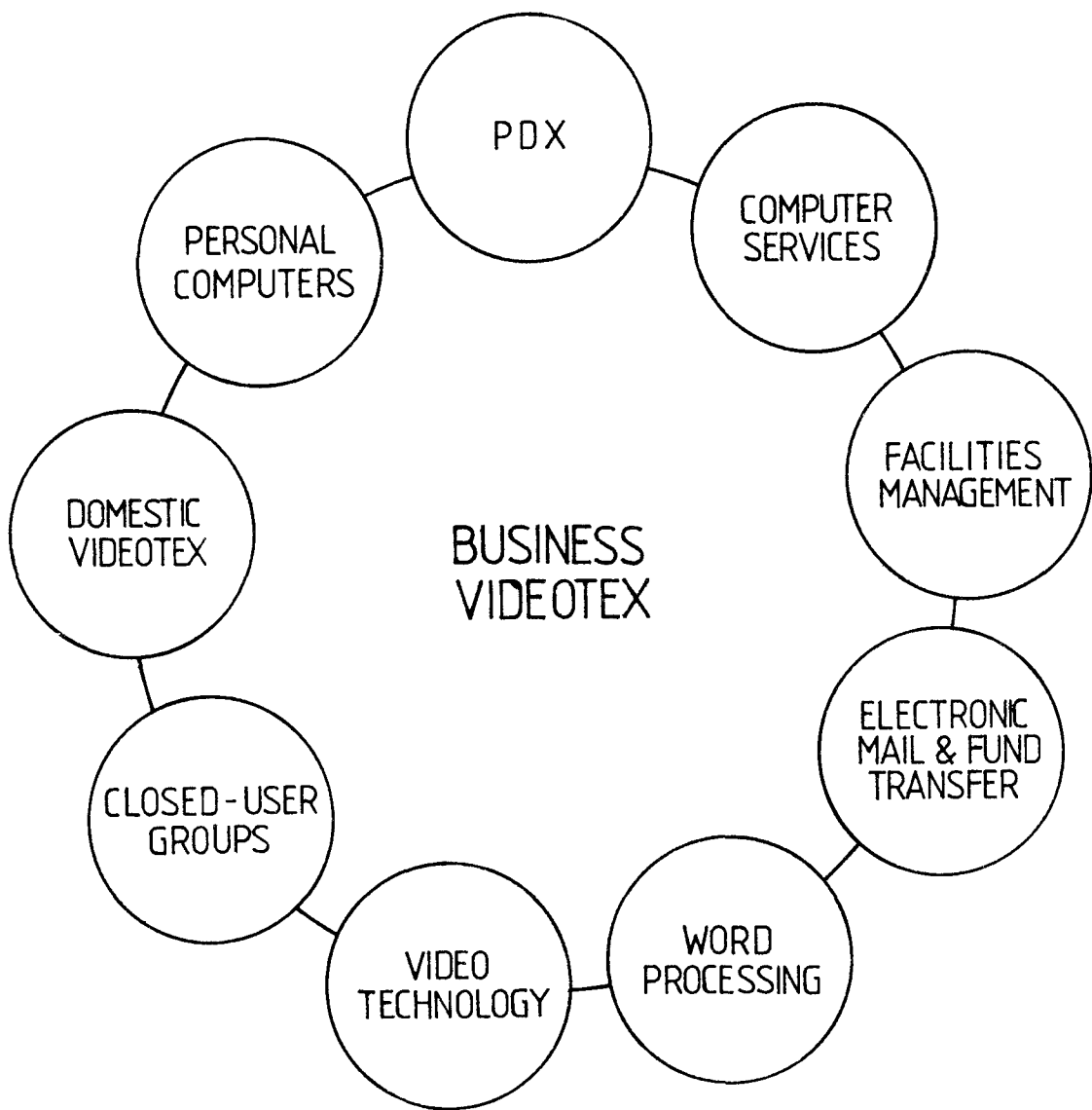

Fig. 1 Positive influences on interactive videotex business markets

mean running systems for given industries, especially fragmented industries as far as the interactive videotex market is concerned. We feel that, in order to have information made accessible to very fragmented industries, firms of one sort or another must organize systems to approach that market in a proper way. The next aspect really deals with the transaction side, i.e., in electronic mail and fund transfer systems... obviously referring to earlier statements about message capability. We see this also as a positive influence on the market. In the case of word processing or text processing, it has a very positive influence in the case of large organizations, but it becomes rather inoperant when taken out of the context of larger companies. Another area which we feel to be very important, and probably of great interest to publishing companies, is the whole concept of video technology. I might just mention that we did a recent investigation of an application combining videotex with a videodisk player in order to reduplicate a large amount of information very cheaply, without having to make it available on a PTT or a private computer system, in which case there is a great scope for certain types of applications. In this way, we also see video technology to be very important. Another aspect, of course, is the influence of closed user groups. We do not differentiate closed user groups as being two separate elements, although everyone knows that they are made up of both internal systems, on the one hand, which we also call closed user groups, and users who have access to certain types of information that others do not, which is in effect a closed user group as well, but are not within the confines of an organization. Another aspect influencing the market is, of course, domestic videotex. Now, one may ask how does that become a positive influence. Well, it becomes a positive influence from the point of component manufacturing, and the fact that, if items are standardized, then the market can spread and become much larger. That is bound to reduce costs as far as the business user is concerned. The next aspect that I touched upon earlier - this morning, in a comment - is personal computers. Our own firm is very heavily involved in this market both as a distributor and research firm, and from technical design and market research points of view. Our feeling is that, if this market is going to become large, it must be accessible to the smallest individual user possible. In a business context, that is probably a one-man professional person, and the cost of buying a terminal or using it as a stand-alone device at today's prices is not particularly feasible to that particular user. However, that said, it is likely that personal computers will become the focus of many field upgrades to include interactive videotex systems. And indeed, in the UK, GEC is currently producing plug-compatible boards just for this particular purpose. I might also add that, in Europe, by the end of 1983 - which is our forecast period -, there should be well in excess of a million installed personal computers in a cost range between \$500 and \$10,000 as a systems price. These markets will

always - at least up until 1990 - run ahead of the installed business interactive videotex terminal base.

Let us turn now to the sad aspect of the situation, namely the negative influences on the market. (See fig. 2.) We can start with what might be considered the purpose of today's conference: the lack of standards. We put this at the top of the list, if for no other reason than the fact that many manufacturers, because of the limiting aspects of this topic, have not invested in a lot of research and development, or specifically involved themselves in a project to develop products. They are taking a wait-and-see attitude, and I suppose that, if you were standing in a manufacturer's shoes, and waiting on the sidelines, then you would obviously wait to see how this conference and other similar conferences turned out, to determine what you should end up doing. If we follow the logic of that over to the next aspect, manufacturer apathy, I feel that today's conference is very poignant in the sense that many manufacturers who should otherwise be here are not... and that's no reflexion on the organizers, but a reflexion that we ourselves have found long before in the market, even in terms of marketing the study. There doesn't seem to be a very keen interest in Europe anywhere to the extent that there should be. Concerning the next aspects, private and public data networks, obviously business users have a choice between various networks by means of which they can obtain data, and various services that conflict with videotex systems. There's a competitive element here. As for low-cost data terminals, this again is part of the competitive aspect of public and private data networks. These data terminals are becoming cheaper day by day. Obviously, given the choice between a pure data network system or the use of a data terminal with one's own internal computer system, then, from a functional point of order, if a user has access to his computer system via a cheap data terminal, he has by far a much greater chance to access more information than through an analogue system. Unions were mentioned earlier. They will be a restrictive element right throughout the whole history - past, present and future - of videotex elements... and I do not see this changing for some time. PTT monopolies - believe it or not - I see as a negative influence, if for no other reason than the fact that certain PTT policies are based on a technology that is now outdated, and those policies do not follow the technology that exists today, but in fact go against the manufacturers' wishes to take the technology they currently possess and use it on the applications that are now being developed. By far and away, these technologies are much more advanced than the applications technologies currently being utilized. Therein lies the conflict. There are numerous methods by which one can gain information very cheaply: newspapers, radio, television, etc. However most of these media elements are financed by some form of advertising, and, to that extent, the market is influenced by what advertisers intend to promote, and the method by which they intend to do it. The



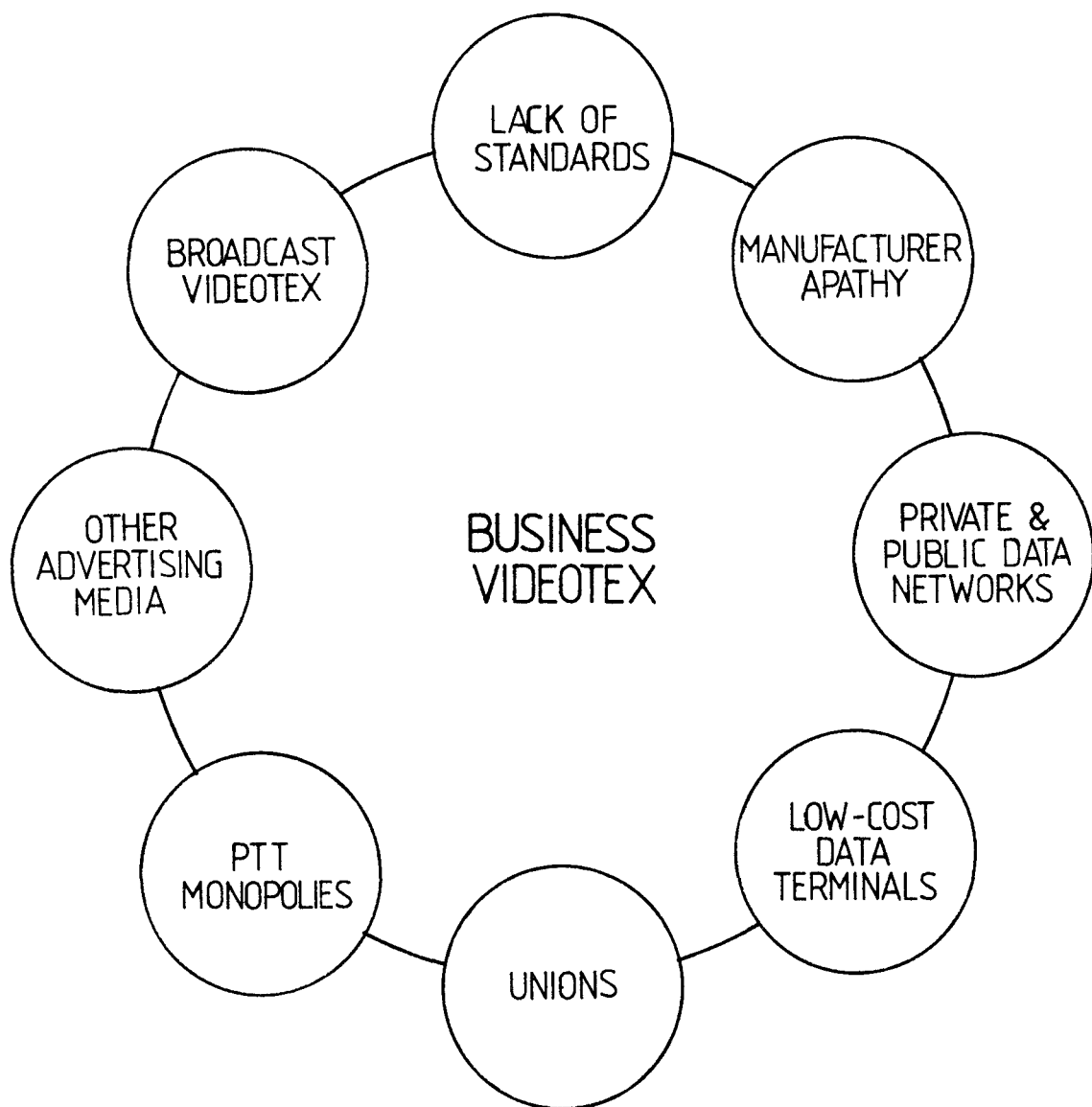

Fig. 2 Negative influences on interactive videotex business markets

last aspect which is negative is broadcast videotex... although we mentioned interactive videotex on the domestic side. The user, if he has a normal television set receiver, can receive a considerable amount of information from a broadcaster. In the case of the United Kingdom, to take a good example, they will soon be going to four different channels of broadcasting. If each broadcast channel were to provide different information frames from each other, and specialize in that way, then the domestic user, or the business user, would have access to four to five hundred frames of information. Now, given that that cannot compete in the same way as a Prestel or interactive videotex system in terms of just sheer volumes of information and choice, it is nonetheless free.

Now, it was said earlier that we weren't talking about markets. But our study has nothing to do with standards, and it has everything to do with markets! In fact we looked at the business market and forecast up to the end of 1983 an installed base of just over six hundred thousand units. And you can see (fig. 3) that the United Kingdom is projected to have the biggest market, obviously by starting earlier and being a very large market to start with. Do not be discouraged by the fact that other countries - such as Belgium, Norway and Spain - have small amounts. This is relevant to the times that these countries are likely to introduce their services. However I might point out that even now, from the original point at which we did this interview work with PTTs and other parties about when they would introduce the service, even these dates are beginning to slip... so one can take a look at these figures and say, somewhat optimistically, that if everyone "gets their act together" (to use a euphemism) then the market should be sure, anywhere in that short period of time, up to that figure.

Now, some markets are very interesting, for example: the Netherlands are thought to be bigger than Italy, bigger than Sweden and Switzerland, yet only slightly smaller than France. We find this to be a very good market indeed. Now, by the way, these figures include both public and private systems: in other words, systems of any sort that a business user would utilize, and includes interactive or closed internal systems. (This is not "public network" per se.) Breaking these figures down, and looking at the distribution by sector by year (fig. 4), we see that the sectors are not static, and indeed many of them change quite a bit. For example, manufacturing sectors of the market are very slow to take off - because there is a high penetration of computer equipment in the manufacturing sectors throughout Europe -, and we project a very steady growth of the percentage of the base... which, by 1983, will go up to 8.6%. The retail and wholesale sector - which is not a particularly good application sector for this particular market - and the utilities sector are projected to be very steady. The

<u>COUNTRY</u>	<u>UNITS</u>
BELGIUM	6,537
DENMARK	22,681
FED. REP. OF GERMANY	161,718
FRANCE	63,976
ITALY	38,465
NETHERLANDS	48,834
NORWAY	2,166
SPAIN	8,717
SWEDEN	30,169
SWITZERLAND	27,694
UNITED KINGDOM	202,735
<hr/>	<hr/>
TOTAL	613,692

Fig. 3 Total European terminal market  
1983 installed base (business videotex)

TERMINAL DISTRIBUTION BY SECTOR BY YEAR

SECTOR	YEAR				
	1979	1980	1981	1982	1983
MANUFACTURING	6.0	6.4	6.8	8.0	8.6
RET./WHLSE.	2.4	2.5	2.5	2.5	2.5
UTILITIES	1.6	1.9	1.9	1.9	1.9
TRANSPORT	24.4	21.9	20.4	20.1	18.9
EDUC./RES.	.4	.5	.5	.5	.5
FINANCE	15.2	12.9	12.0	11.7	10.9
HEALTH	1.4	1.4	1.3	1.3	1.3
GOVERNMENT	2.5	9.5	11.2	11.0	11.8
OTHERS	46.1	43.0	43.4	43.0	43.6

Fig. 4 Terminal distribution by sector by year

transport sector - which, at the moment, tends to take a very large percentage of the revenue or the number of terminals installed, and in fact the activity - is expected to decline, not in terms of its numbers but in terms of its percentage of the base. Education and research is a very small sector to start with, in terms of the number of users. I think that was mentioned earlier. In terms of sheer numbers, it is not a very large sector, but it is nonetheless steady. The finance sector played a very important part at the beginning of the service, in terms of supplying economic information, stock market quotations, etc., but this market is expected to decline in terms of percentage, but it is still a very considerable amount. Health: again steady. But here, with government, we have the one sector which - I think everyone would agree - will always be a growth sector. In fact, maybe a large percentage might be EEC terminals here at the Commission. I don't know... We see the market quadrupling, at least, over the five-year period, to attain 11.8 percent of the market. Much of the influence of this sector comes from the individual country administrations influencing the purchase of these terminals for their own use. What is significant about all these figures is the "others" sector. This includes all those fragmented little industries which cannot be conveniently placed in the other eight sectors. For example, the real estate sector, light engineering, construction firms, agriculture (all those farmers that were talked about earlier), forestry, people like that... These sectors will form, in terms of sheer numbers, the largest part of the market. I think there's a very good reason for that, which is logical, in that these groups do not at present have access to information systems of one sort or another, primarily because they are too small, and because they have very particular requirements. It's not too difficult to think that, because their information requirements are just as expedient as any other large manufacturer or large representative of any of the other sectors, they would corner their major share.

In fig. 5, the four countries up the top are currently experimenting and operating systems. The expected share of the UK can be seen to diminish by over 50% during the next five-year period. This is not to say that the UK is not a slow-growth market, or that it's losing out; this simply indicates that, as other services start up in other countries, and grow at faster rates, the percentages begin to alter appreciably.

Obviously, if you can forecast the number of terminals to be installed, you can get some idea of the number of calls, or data traffic, that will be generated. What we mean by an inquiry call is that you pick up the unit and dial some sort of data base, and that inaugurates a call. As to how many frames of information you actually utilize on that particular call, that is anybody's guess... but an average has been proposed of from five to ten. This, I think, is the sort of

PERCENTAGE OF INSTALLED TERMINAL  
MARKET BY COUNTRY

1979	–	DENMARK	–	7.46%
		HOLLAND	–	16.07%
		SWEDEN	–	9.95%
		U.K.	–	66.52%
1983	–	DENMARK	–	3.7%
		HOLLAND	–	8.0%
		SWEDEN	–	4.9%
		U.K.	–	32.9%
		FRANCE	–	10.4%
		GERMANY	–	26.4%
		ITALY	–	6.3%
		NORWAY	–	.4%
		SWITZERLAND	–	4.5%
		SPAIN	–	1.4%
		BELGIUM	–	1.1%

Fig. 5 Percentage of installed terminal market by country

information that will vary enormously from country to country (see fig. 6), depending on viewing habits and just sheer inquisitiveness, and the fact that the data base being called is varied and large... so these figures are likely to change enormously. We see that the Federal Republic of Germany will be almost as large a market as the UK by 1983.

One of the things we did in our study was to ask users which manufacturers they preferred. (See fig. 7.) And the curious thing is that, when you go to visit any large company in Europe, and you ask somebody to talk about interactive videotex systems, and what the company's policies will be, you inevitably get shunted down to a data processing manager, who in general has the responsibility for the entire information processing policy of his company. And when you talk in Europe to a data processing manager, 50% of the time you're talking to somebody who has bought IBM equipment. So, when asked who they expect to buy their equipment from, we find that IBM in Europe is probably the most popular, CII Honeywell Bull would obviously be popular in France, but after IBM, and ITT of course very popular in Germany, and slightly in Holland and Belgium where obviously they have a large operation. Philips was mentioned, but, if you look at the countries they are mentioned in, they're generally very small markets. Ericsson, you would expect to dominate Sweden. And one looks at the PTT figures... and one must bear in mind that the PTT suppliers are more than likely going to be all the other manufacturers, so one could spread the load from those groups. The UK is a curious case. Almost nobody wants to buy a terminal from the British Post Office, in the business market; they prefer to buy them from some manufacturer, although they're not quite sure which one it ought to be. In Germany, we do not see Nixdorf, Telefunken or Siemens mentioned at all... yet we interviewed some of the largest companies in Germany. It is interesting to wonder who will end up dominating the market.

In the MWS Services documents, we have mentioned our view of the market, and I would just like to reiterate that here before I summarize our study. First of all, we view the market as composed of three separate elements: information providers, manufacturers and network providers, predominantly PTTs. If one views this triumvirate as a three-wheeled bicycle trying to pedal up a hill, and if the hill is in fact user resistance, then they are going to have to pedal very hard, all three of them, for that bicycle to reach the top of the hill... from which, metaphorically, it will coast all the way down to the rest of the market. And it may not even be an interactive videotex market; we don't know. But the key point here is that, if one of the cyclists does not pedal very hard and fast - e.g., one of the manufacturers, who look as if they are the first ones to drop out... or an information provider who may become disinterested by the mere fact that the market is not growing very fast -, then the other two elements are going to have to pedal that much harder. And

FRAME INQUIRY CALLS BY  
COUNTRY (1983)

	NUMBER	%
BELGIUM	2,564,530	.7
DENMARK	12,656,851	3.3
FRANCE	39,600,093	10.3
FED. REP. of GERMANY	100,670,873	26.2
ITALY	13,585,490	3.5
NETHERLANDS	33,499,546	8.7
NORWAY	734,700	.2
SPAIN	3,241,850	.8
SWEDEN	18,969,139	4.9
SWITZERLAND	19,246,817	5.0
U.K.	139,792,558	36.4

Fig. 6 Frame inquiry calls by country (1983)



USER VENDOR PREFERENCE BY COUNTRY

	ITT	IBM	CII HB	PHILIPS	L.M. ERICCS.	PTT	OTHER
BELGIUM	3	2		1			
DENMARK		2		3		1	
FRANCE		1	2	3			
F. R. GER.	1					3	2
ITALY		2				1	3
NETHERLANDS	3	2		1			
NORWAY				2		1	3
SPAIN		1				2	3
SWEDEN					1	3	2
SWITZERLAND						1	2,3
U.K.							1,2,3

1 – MOST POPULAR

2 – SIGNIFICANT PROPORTION

3 – MENTIONED

Fig. 7 User vendor preference by country

obviously, if two of the elements don't pedal very hard, and don't carry their weight, then the third element is just going to become discouraged, and the whole thing will just fall flat on its face.

I would like to summarize what we at MWS think that each of these three elements should do. First of all, information providers. I'm very pleased to see, at the early stages of formation of policy in many PTTs, the allegiance now being switched from the domestic market to the business market. In our view, information providers will have to concentrate on business users in the early formative years. For example, as our EBU representatives here will no doubt know, an average European colour TV set takes a minimum of ten years to replace in the base. To the person who has just bought his 26-inch PAL remote-controlled TV to be told that it is now obsolete and must be replaced, one, two or three years after he has purchased it, is not going to go over very well. And I'm not surprised to see that only twenty thousand Teletext users have sets in the United Kingdom. From our point of view, the domestic market is obviously a long-term proposition. But think of the information provider. Is he going to become discouraged? Does he have the resources to last out the ten to fifteen years until the base becomes viable, and so that his money that he has spent on providing that information and services is going to show a return? I know that most financial directors of major information companies of one sort or another will take a very jaundiced view of having to look to a ten to fifteen year market policy plan... especially given the indecision and lack of standards and other elements affecting the market.

From the point of view of the user, nobody wants to be charged for indexing, branching or reference frames. I don't think you would like to pay for them, and I don't see why you would expect others to pay for them. If you are an individual information provider, you should provide direct advertising to your market.

As far as facilities management and computer services companies are concerned, they are a key element in making the market happen, especially if the volumes are going to be there. They will broaden the market in many ways, and many PTTs should co-operate at every level, in terms of software development and helping to offer the services to their customers.

Now, since our study was primarily directed towards manufacturers (at least the commercial version), our recommendations were as follows. Somebody mentioned earlier that the participants in this market were TV manufacturers. In my opinion, the biggest participants in the market are in fact communications suppliers and, after that, computer manufacturers... although two of the largest TV manufacturers in Europe - namely Philips and ITT - are also communications

manufacturers, so it's logical for them to spread the load across various elements and segments of their own companies. But, as far as the domestic market is concerned - and this is the most important part of the relationship between the business market and the domestic market -, if you're going to standardize a product, you should appreciate that the terminal must become extremely inexpensive for the domestic user to become interested. One of the ways to do that, in our opinion, is to manufacture a device which is built around the home telephone, and has a screen of some description, and has the ability to look up and be integrated with other services in the future. Manufacturers are likely to be more interested in the market if they can see a replacement telephone market opportunity. Colour is obviously a benefit, and we think that most users prefer it. The real problem that colour creates is based on current technology and the usage of videotex systems: the resolution for colour TV is not the greatest thing in the world as far as a business user is concerned. And this stems back to the fact that, in the original development of videotex systems, they were based on domestic television set formats... and not on the very different requirements of business users. We feel very strongly (and this will probably make the British Post Office very happy) that the modem and decoder and the auto-dial facility must be integrated into the device as far as the business community is concerned. The last thing a businessman wants on his desk is five little boxes cluttering up the space.

Standards must be agreed upon, especially to reduce components costs... but I would like to point out that, for many users, the price of terminals being offered on the market is acceptable, given that prices are not likely to drop a lot, even with standards, as long as we stick to current technology. The major cost of the system is not in the modem or the decoder chip; it's in the plastics and the selling and the marketing of the product.

Private systems should be encouraged at every opportunity, in conjunction with PTTs. Somebody already mentioned that, from a PTT point of view, they are interested only in generating line traffic. If this is true, then you should encourage everybody in the private sector to participate in the system... although I think that's a rather narrow view to take, and manufacturers are not particularly happy with that outlook.

As far as PTTs are concerned, I think that we must at least agree upon European standards... which would make the European market pretty much a lake for European manufacturers. A worldwide standard is improbable, particularly if one had to integrate Japanese systems.

On the subject of the normal analogue telephone sets to be used in business and domestic videotex, I think that PTTs should rent sets or buy them in bulk from European

manufacturers for their markets... just as they originally did. We view this merely as an upgrade market for manufacturers. An increased monthly rental for terminals using videotex and voice functions could provide a great boost to the market, especially for domestic users. I'm speaking of spreading the costs over two markets. In our view, in Europe, there are only four markets which can actually support a business market on its own, and they are the UK, France, Germany and Italy. Holland and Sweden are marginal markets, because the business communities are not large enough to support a public offering, or even a private offering, in interactive videotex systems. Therefore PTTs are going to have to promote smaller private offerings in each country that does not have a very large business community. And, of course, this is complicated by the fact that there are different foreign languages and so forth.

From a future point of view, if PA is forecasting the death of videotex as it is now configured, in the near future, or at least somewhat near future, then what we view is its integration, and not necessarily its death.

To summarize, the European business market in general is very receptive to videotex. The market, therefore, is there... and it needs to be exploited and handled in a proper manner. The domestic market may never succeed, therefore the business market must be the centre of current activity, at least for the next five to seven years. Standards are needed to reduce costs, primarily for domestic users, and laterally for business users. Functionality must be wide-spread to ensure the success of the system, especially in marginal markets. Integration with personal computers is a must, to bring in the bulk of small business users who have a greater need for the system on an individual basis, and who are likely to generate high levels of traffic for their own particular use.

## LECTURE: Standards for Text Communication

*Mr. H. McGregor Ross, Data Systems Consultants, London*

"Text communication" is an expression which has been created to cover the subject we're looking at even more widely. It of course includes videotex. It also includes Teletext, the teletex service of the PTTs, word processing and even certain aspects of data processing. And it's only through seeing videotex in this wider environment that we can get a good view.

We've talked often of standards, but any consideration of them must be done with discrimination. Let me mention the main rôles or purposes of standards in this field. In the first place, they allow for the meaningful interchange of texts. Secondly, they provide access to data bases. Thirdly - and this is an increasingly important rôle -, standards are required in international foreign-language and multilingual usage. Especially with the development of the Community, we not only have a great increase in international trade and international cultural relations, but we can expect that to grow even more... and it's exceedingly important that we should be able to have effective interchange of texts in these languages which are not our own languages. The next crucial point of having standards is to avoid the necessity for prior bilateral negotiation. One just wishes to be able to send a text to somebody else, and to make sure that it can be meaningfully interchanged without going through a long preliminary negotiation about what it means.

Standards in this area must respect each country's established needs. We have very long-established practices to do with texts and our languages and the letters and characters we use in them, and these must be respected. And furthermore, standards should not impose uniformity. Whenever there is a legitimate national difference, standards must respect it.

In order to meet those objectives, the main areas of standardization which are important, in my view, are firstly open system interconnexion. Many of you will have heard of this new field of work, which is to permit computer-like machines, or terminals (including videotex terminals), to communicate with each other openly, in the same way that the telephone enables us to communicate with anyone else. This is a very difficult subject, but good work is being done on it already.

The second area is open data interchange. Now this is very little known. Some very important work has been done to permit trade documents to be interchanged for international trade, and there are some new virtually worldwide standards on open data interchange for trade documents. Mr LAYTON has at present a half-million dollar study under way, extending these concepts of open data interchange into wider areas of use. And yet there are very few people who even know of the existence of this subject.

The third main area is in telecommunications and data interchange. These domains are already well covered by standards.

The fourth crucial area concerns the format of the frames of videotex, to permit their interchange. It's going to be critically important, to information providers, that the investment they make in one country should be interchangeable to other countries.

Fifthly, there's the question of character sets and coding.

Now the standards-making process is a distinct activity, with techniques of its own. It's essentially a matter of coming to a consensus agreement, among representatives of a wide range of interests. Standards are not imposed, nor do they exist only for narrow sectional interests. All standards-making is dependent upon receiving proposals and working examples. And these proposals are studied by these representatives of the wide range of interests, and gradually improved and modified until there can be a consensus agreement.

The study which I have done for the Commission is to do with character sets for text communication, and it is an example of one of these proposals which may be used in the standards-making process. I am now going to concentrate on the main features of this specific proposal, and not deal further with generalities. This study considers all aspects of character sets for text communication. One of the peculiar aspects about working on character sets is that all aspects must be considered, and nothing significant left out. And this study does propose a scheme on this subject, which is simple... and which does meet all the requirements, and which does solve all the problems. This is something we've never had before. And furthermore, this study and its proposal go very far towards harmonizing equipment design, with - of course - the benefits which will result from that, both in manufacture and use.

Fig. 1 attempts to show the overall picture of the text communication process. On the left-hand side, we have different types of terminals. Up at the top, we have the most general text communicating terminal, which is shown connected to the networks, on the right: Euronet and all the other public data networks which the PTTs are establishing. And one

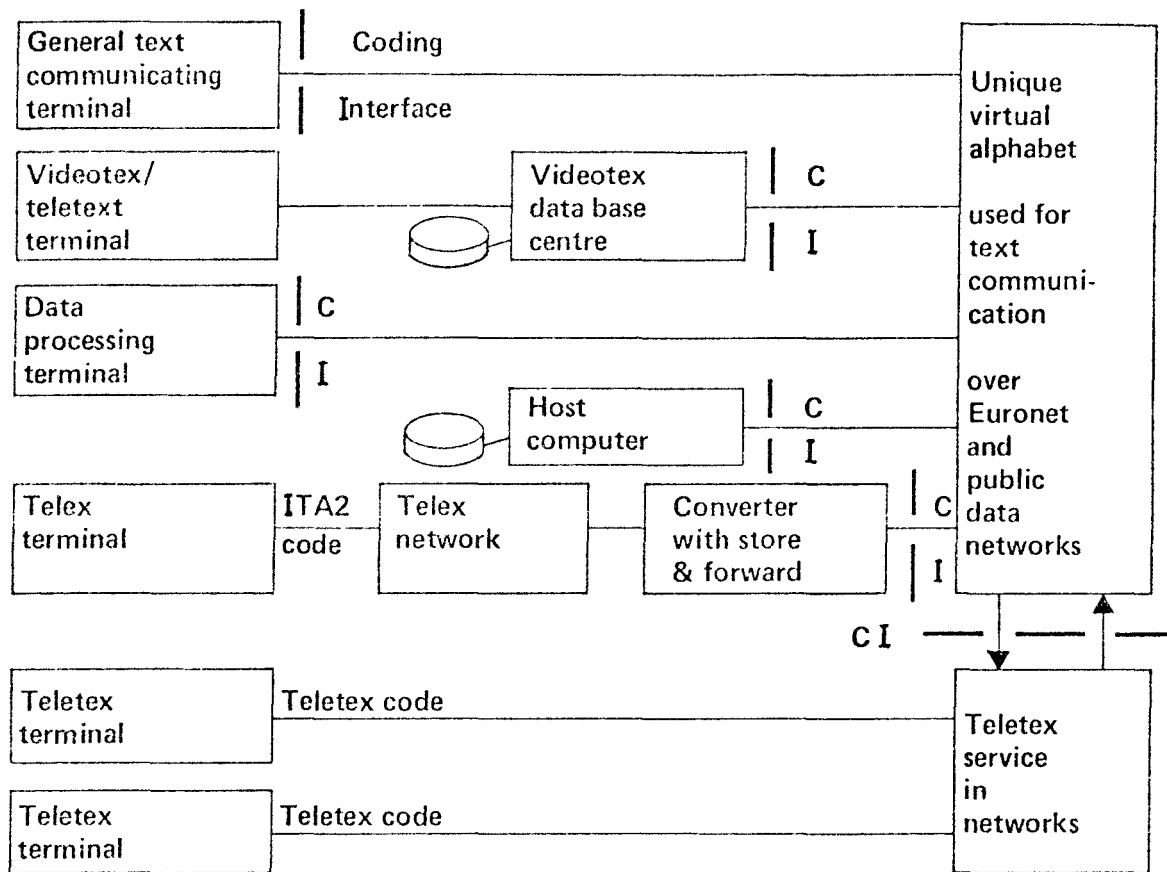

Fig.\_1 Overall scenario for text communication

wants to envisage a large number and variety of these general text-communicating terminals, communicating with each other into the network and back again. Another class of terminals is the videotex or Teletext terminal, connecting to its own centre, and then onwards to the general networks. A third class is the conventional data processing terminal connecting through the network to the host computers. Now this is Euronet. Towards the bottom of fig. 1 we have the telex terminals connecting to the world-wide telex network... and we show that it is possible to link up telex to the general networks such as Euronet. With this concept, any of these terminals can communicate with any other by going round into the general network. The figure also shows, down at the bottom, the teletex terminal currently being proposed by the CCITT. Two of them are shown running into the network. Now the CCITT is making proposals for a specific character code for teletex, and this has some serious disadvantages built into it, which will become apparent in about two years. If work goes ahead as presently planned, they are heading for disaster. In any case, they are going to get some sort of a teletex system running, and we must make sure that this system will be able to communicate with all the other services shown in fig. 1.

In fig. 2, we see that the Antiope type of terminal may be accessed by television techniques, or interactively over the telephone line, and it will communicate over the network with its database computer. In the same way, we have the Viewdata type of system, accessed by television or over the telephone circuits, and in each case running into its own centre, with the attached data bases. We also see the private or business videotex terminals which could connect into the network and back again into private videotex centres. With this concept, all these terminals could interconnect through the network with each other, and we obtain complete international communication.

Now the key features of this scheme are, firstly, that there should be what I've called a coding interface. Those of you who are familiar with data transmission will be aware of the interface V24 and so on, which has been the basis of the establishment of data communication... and this is an extension of that idea for coding. On the side of this interface which is remote from the network, we have what the telecommunicators call DTE: data terminal equipment. Some of these DTEs may be simple terminals, even as simple as a teletypewriter. On the other hand, some of them may be DTE systems, and Antiope, for instance, becomes a single DTE system, and Prestel too. Now the whole idea behind this is that coding conversion can take place at the coding interface, and therefore the character coding within each DTE system can be independent of the character coding in the network. The character set used in the network - which I call a virtual alphabet - is a superset of the character sets used in all terminals. This means that any terminal wanting to



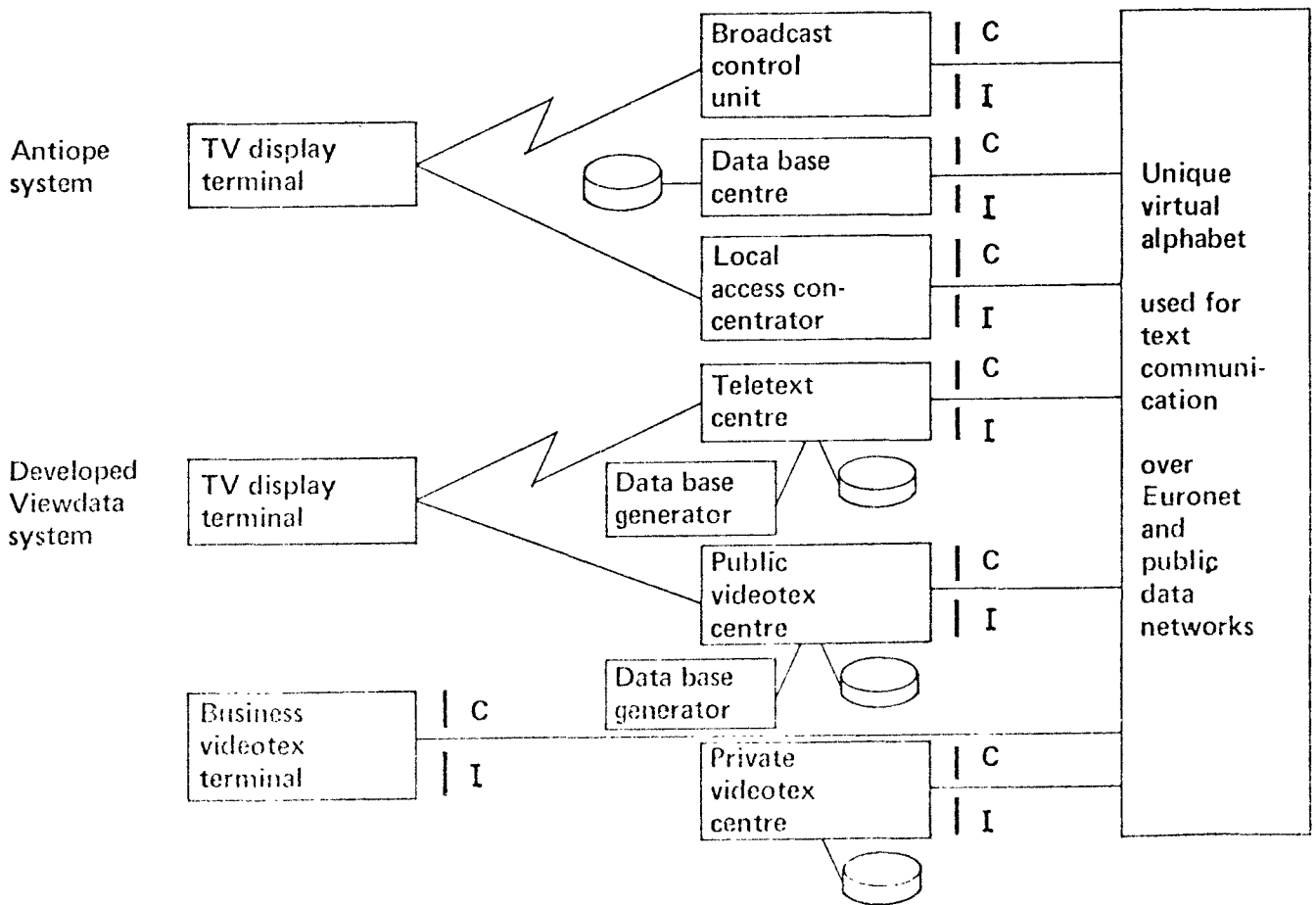

Fig. 2 Coding interface applied to videotex and Teletext

communicate will find an appropriate facility in the network. The DTEs will generally use a subset of this virtual alphabet for storage and receiving. Now the storage aspect is very important, because it's here that we have the great investment of the information providers. There will be even simpler subsets used on keyboards. The idea is that a terminal should make an attempt to receive everything that is sent to it, but a sender need only send what he wants to send. For example, a terminal in Germany should be able to receive French, Hungarian, Scandinavian... whatever comes to it... but the German user need only have an ordinary German keyboard for generating the German language, if that's what he wants. Of course, if he wants multilingual capabilities, as in Switzerland, then he requires a more complicated keyboard.

Within the DTEs, we can finish up with a western regional subset. This is a single unique repertoire of characters and their coding which satisfies the needs of all the countries of Western Europe. If one draws a line on the map to include Finland, Germany and Italy, then all the languages used on the west of that line can use a single character set... which Mr VERNIMB and I have nicknamed the "Euro-Alphabet". In fact, it's more than that, because it satisfies the needs of North America, including Canada and Mexico, and the whole of South America. Another very important feature of the scheme is that it provides great harmonization of printers, displays, storage and videotex. Now the consequences of this proposal for videotex are, first, that Antiope and Viewdata systems can coexist. For months there have been very acrimonious arguments over the character coding of these two systems... and this proposal makes those arguments unnecessary. Secondly, it permits a very simple enhancement of the Prestel system to permit all Continental languages: not only the Western European languages, but other Continental languages such as Polish, Lithuanian and even Turkish. The third point is that it makes the data bases interchangeable between Antiope and Viewdata centres, and furthermore it makes these data bases interchangeable between the videotex centres and the Euronet host computers. And only one "Euro-chip" need be made to display the Euro-Alphabet. This means one chip of this nature for 75% of the people in the world who use the Roman alphabet, and it permits very simple national keyboards on videotex interactive machines.

Let me summarize my presentation in the following way. Character coding has always been fundamental to the interchange of text. These proposals are the key to the lock, and they unlock the door. The Commission, by implementing these proposals - first of all in Euronet, then in the Euro-chip, and then in printer equipment that could ultimately be developed into a superior office typewriter - can open that door. And when they open it, everyone else can walk through.

# TEXT: Character Sets for Communication of Text

Summarized extracts from the study report:

*Data Systems Consultants, London*

## THE ROLE OF STANDARDS-MAKING ORGANIZATIONS

The primary group for standardizing character codes is Subcommittee 2 (character coding) of Technical Committee 97 (information processing) of the International Standardization Organization. ISO/TC97/SC2 is the main forum where the world's experts on character coding can meet - few though they are in number - and can develop standards which, by a process of review and amendment, finally attain a wide measure or consensus of agreement. The procedures within ISO, even though slow, are designed expressly to attain such agreement.

Other groups currently involved in related work are the CCITT Study Groups I and VIII and corresponding CEPT groups planning the teletex service and equipments. Some individual members of the ISO coding committee attend the CCITT meetings. The European Broadcasting Union has recently set up a working party to consider character sets for Teletext, but there is no direct contact with the ISO coding experts.

## CANDIDATE CODE PROPOSALS

### PRECIS

Fifteen proposals have been made for character codes for text communication. Broadly, they fall into three classes:

- those that are specific to videotex or Teletext;
- those that rely on constructing certain graphics out of sequences of characters, especially for accented letters;
- those that rely on transmitting composite accented letters, resulting in a large number of national variants.

### CODING PROPOSALS SPECIFIC TO VIDEOTEX OR TELETEXT

#### 1. UK Teletext and videotex

British Teletext services have gone into operation with a 7-bit character code structured somewhat like ISO 646, with the colour and other attribute controls in columns 0 and 1, and a set of graphics chosen for British use. As it

stands, this cannot provide for accented letters. This code was adapted for UK Viewdata, coming nearer to ISO 646 and ISO 2022. A primary objective was to minimize terminal costs, and both systems can use many of the same components.

## 2. UK proposal for extended videotex code

To meet the need for accented letters, British Post Office workers proposed an extension of the above proposal for videotex in which two further sets of accented letters would be provided, one for Western European countries and the other for Eastern countries. Relying still on 7-bit transmission, each accented letter would be called by a SS2 or SS3 shift character.

## 3. Proposal for extended Teletext scheme

Mr John Chambers has proposed a scheme whereby the characters of the first system, above, are transmitted in an 8-bit code, the resultant extra space being used for accented letters.

## CODING PROPOSALS BASED ON CONSTRUCTED CHARACTERS

### 1. The CEPT proposal

A scheme originating from Antiope workers was presented in the name of six PTTs to the CCITT. It relies on a 7-bit 2-shift code. Accented letters are constructed from an accent character and a letter character.

### 2. An enhanced Antiope proposal

Characters would be transmitted as above, but the terminal equipment and the processor at the centre would associate an 8-bit sequence for attributes (colour, flashing, etc.) with each 8-bit graphic character. In other words, 'characters' could be 16 bits long. However, when the attribute of a following character is the same, the attribute octet could be omitted. This system could be used for both videotex and Teletext, and perhaps for other services.

### 3. The ISO/WG4 proposal

The CEPT proposal has been used as the basis of a standard specification being drafted within WG4 of ISO. Additional concepts relate, for example, to teletext requirements.

### 4. The 'German compromise' proposal

This is a compromise between two of the systems mentioned above: the UK Teletext and videotex system and the CEPT proposal. The languages of Europe are put together in groups, and the accented letters of each group are squeezed into

some columns of the 7-bit code table, or replace less-important symbols.

5. The 'BSI' proposal

This is an 8-bit code with accented letters and some other graphics being transmitted as triplets or quadruplets of characters, the second of which is 'backspace'

6. Dr Neu's initial proposal

Dr Neu, of the Swiss PTT, has suggested that accents should be placed in the national-use positions of ISO 646.

7. Dr Neu's enhanced proposal

This is a development of the earlier proposal.

8. The current CCITT teletex position

This is closely related to the above-mentioned CEPT proposal.

CODING PROPOSALS BASED ON COMPOSITE CHARACTERS

1. The basic IBM proposal

IBM has proposed that accented letters should be coded as single characters, and that sets should be arranged and coded in 7-bit form, with a set for each country optimized for its needs. This approach is characterized by the premise that the sender should know how the recipient's equipment will behave, and should adapt the sent message accordingly.

2. Enhanced IBM proposals

IBM has put forward developments of the basic proposal.

3. Mr de Bournonville's proposal

This concerns an international teletex set, based on 7-bit codes. There are 21 local teletex codes, in each of which the less-used graphics in the IRV are replaced by accented or special letters or extra symbols.

4. American draft standards

The US standards committee X3L2 has proposed a set of 96 graphics for word processing applications, in which 7 ASCII graphics are replaced by 9 others. There are no provisions for accented letters.

## A SUGGESTED CHARACTER CODING SCHEME

The main coding proposals put to CCITT and ISO/WG4 contain many supplementary suggestions, some implicit and some stated explicitly. It has been found that, by making a selection of these and combining them together by means of general concepts used in other fields of computing, a comprehensive character coding scheme for text communication can be suggested. Such a character coding scheme is optimized specifically for the communication of texts used in the professions, industry, trade and commerce. And it presupposes that processor intelligence is available in, or associated with, terminal equipment. The scheme is suitable for all national and international communication in the languages based on Roman alphabets, and it can be used in multilingual countries or organizations. To combine together the selected elements, certain concepts - new to character coding work - are used:

- 1 - The totality of a text communication service, taking into account practical requirements, is seen to consist of components, whose character coding requirements are independent, but may be inter-related by exploiting processing capability.
- 2 - The major components are as shown in fig. 1, where the transmission process is generalized in the telecommunication networks (but may also include data interchange on tape or disk media, etc.), and all the different kinds of terminals, including host computers or computer centres, are regarded as data terminal equipments (DTEs).
- 3 - A coding interface is conceived between each DTE and the network. At this interface, code conversion may take place.
- 4 - Thus, the coding requirements of each DTE are decoupled from the main transmitted code used in the network, and can be optimized to suit the DTE.
- 5 - Further, each DTE is decoupled from all other DTEs.
- 6 - Within a typical text processing or teletex terminal, sub-components may be identified, as in fig. 2, and their coding requirements may be decoupled.
- 7 - Thus, the keyboard capability may be decoupled from the display or printing functions. This allows the presentation capability to cope with all coded data being received whilst leaving the demands on the keyboard to be dictated by the user's local requirement for sending.

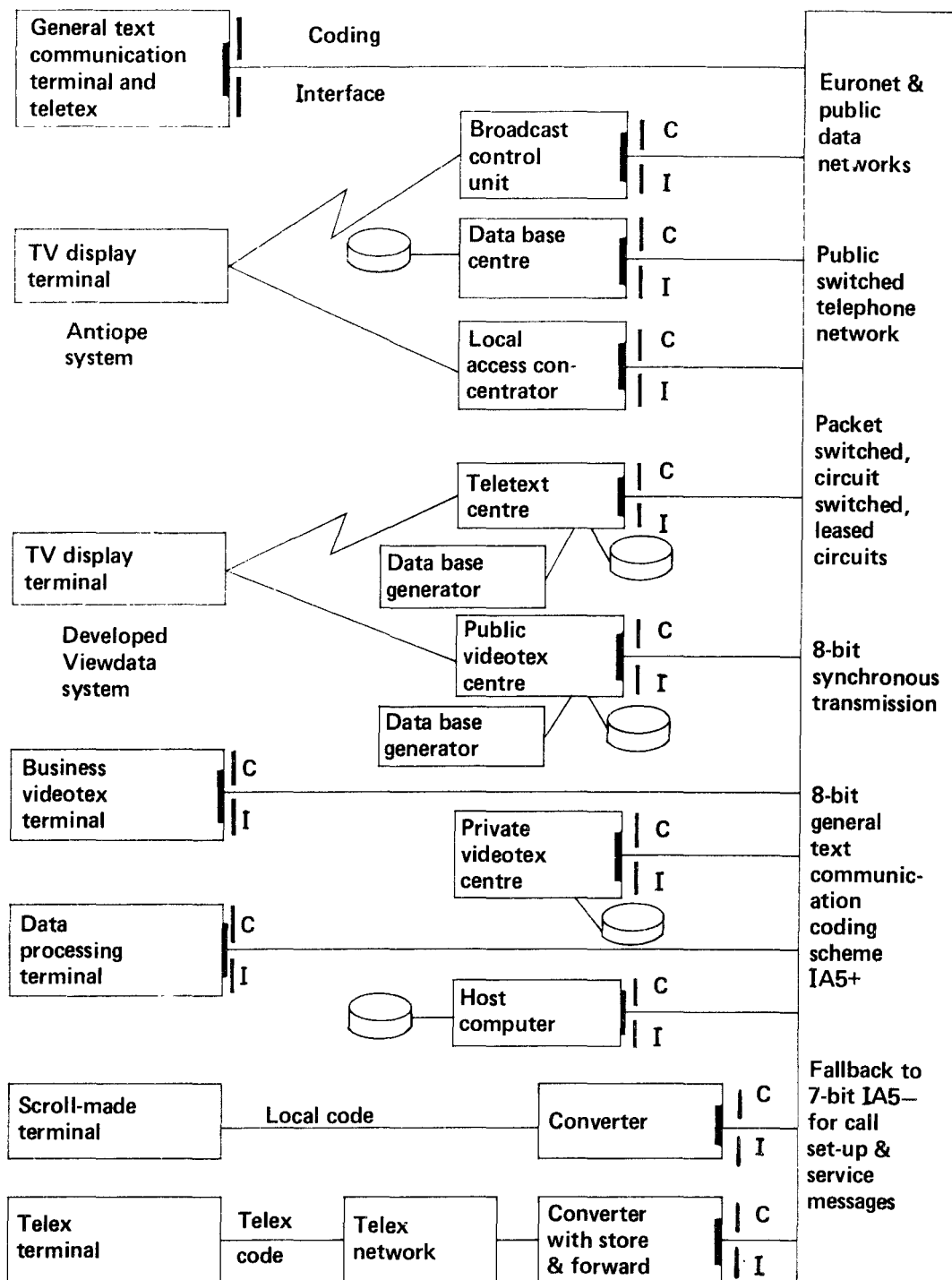

Black boxes indicate converters; if outside rectangle, have to be added to existing equipment.

Either-way transmission throughout, except broadcast teletext.

Unless otherwise stated, all communication uses 8-bit general text communication scheme.

Fig. 1 Scenario of the general text communication service

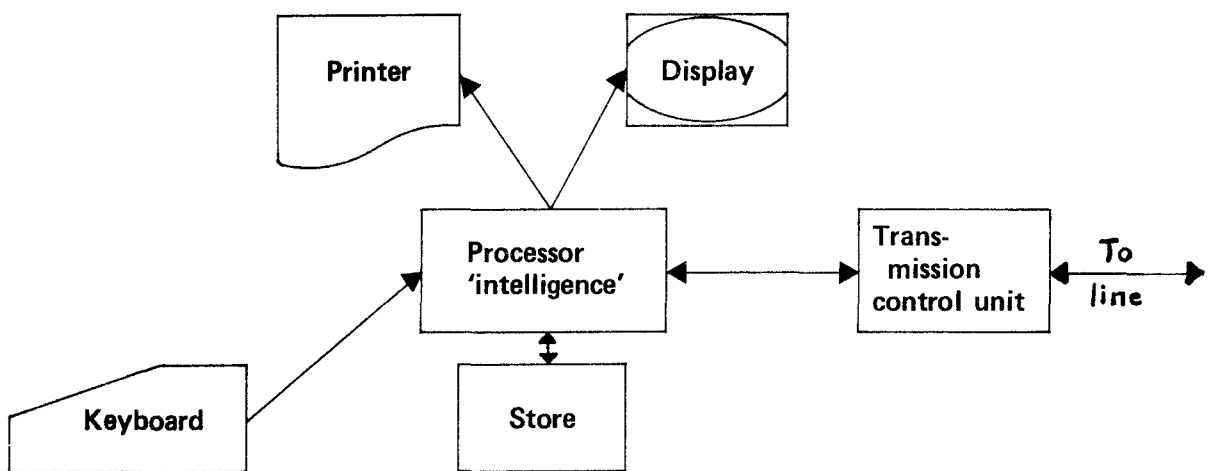

Fig. 2 Sub-components of a typical text communication terminal



## THE TRANSMITTED CODE

The character code used for transmission in this service - either in the general networks or on various data interchange media - is now decoupled from the requirements of the DTEs and may be optimized for its own function. This may be regarded as a virtual alphabet: a unique code used without any deviation, and comprising a superset of the graphics and control functions required in the DTEs. In fact, the virtual alphabet would be defined for this service at the coding interface. It may be a significant advantage that only one code is used in the networks for those PTTs that might, at some future date, wish to offer 'value added' facilities associated with the text communication service. It is suggested that the virtual alphabet be based on the above-mentioned CEPT proposal, using the work of ISO/WG4, with further refinements. Accented letters are transmitted as accent/letter pairs of characters, and certain control functions are transmitted as sequences of characters. To avoid an unmanageably large number of such combinations, it is suggested that the useful ones should be recognized, by consensus agreement. Currently, provision is made for about 300 characters and combinations.

## CODE TABLE OF THE VIRTUAL ALPHABET AND REPERTOIRE OF GRAPHICS

The complete code table for the virtual alphabet that is suggested for transmission in the general text communication service is shown (fig. 3) in its preferred 8-bit form. If used in 7-bit form, columns 0-7 would be called by Shift In, and individual graphics in columns 10-15 by Single Shift 2.

## REPERTOIRE OF CONTROL FUNCTIONS

The repertoire of control functions to be recognized in the virtual alphabet for the general text communication service is currently being considered within ISO/WG4. The matter is quite straightforward, and few difficulties are likely to arise. It is a matter of identifying the control functions that will be needed, their coding being mostly settled by ISO 646 and ISO 6429. The main outstanding question concerns the overlap between virtual terminal protocols - which provide for formatting of text, for example - and the use of coded characters embedded in the data stream.

	0	1	2	3	4	5	6	7	8	9	10	11	12	13	14	15	
0	NUL		SP	O	( <sup>5</sup> @) <sup>6</sup>	P		p				0	<sup>6</sup> Æ	<sup>20</sup> SOQ	<sup>6</sup> æ	<sup>20</sup> SCQ	
1		(CUR ON)	!	1	A	Q	a	q			<sup>12</sup> ,	<sup>16</sup> 1	Ø	<sup>20</sup> DOQ	ø	<sup>20</sup> DCQ	
2	(STX)	(DC2)	<sup>2</sup> " <sup>3</sup>	2	B	R	b	r				<sup>16</sup> 2	<sup>6</sup> Œ	<sup>21</sup> ä	<sup>6</sup> œ	<sup>2</sup> ö	
3	(ETX)	(DC3)	#	3	C	S	c	s			^	<sup>16</sup> 3	<sup>6</sup> Ŭ	<sup>2</sup> i	<sup>6</sup> ij	<sup>2</sup> ı	
4		(CUR OFF)		4	D	T	d	t			~		μ	ℳ	(←)	ℵ	(→)
5	ENQ	NAK	%	5	E	U	e	u			<sup>12</sup> -		±	<sup>6</sup> Đ	(↑)	<sup>6</sup> đ	(↓)
6	ACK	SYN	&	6	F	V	f	v					÷	℥	(¼)	℥	(¾)
7	BEL		<sup>2</sup> ' <sup>4</sup>	7	G	W	g	w			°	<sup>17</sup> §	<sup>6</sup> Ɔ		<sup>6</sup> Ɔ		
8	BS	CAN	(	8	H	X	h	x			.	<sup>18</sup> ¶	Ł		ł		
9	(CUR →)		)	9	I	Y	i	y			<sup>13</sup> □	<sup>14</sup> .					
10	LF	SUB	*	:	J	Z	j	z			∇	<sup>19</sup> —					
11	(CUR ↑)	ESC	+	;	K	[	k		<sup>10</sup> SSB	<sup>11</sup> CSI	˘	\$					
12	<sup>1</sup> ToF		<sup>2</sup> , <sup>12</sup>	<	L		l	<sup>9</sup>	<sup>10</sup> SSP		"	£					
13	CR		<sup>7</sup> -	=	M	]	m				<sup>14</sup> '	¥					
14	SO	(CUR HOME)	.	>	N		n		SS2		<sup>15</sup> ˘	¢					
15	SI		/	?	O	<sup>8</sup>	o	DEL	SS3		˘	½		<sup>6</sup> β			

Fig. 3 Complete code table of the suggested virtual alphabet

## VIDEOTEX AND TELETEX IMPLEMENTATION

Videotex and Teletext may be regarded as DTE systems, each with its own coding arrangements for terminals, local transmission over the PSTN or data networks, and the computer centre... all beyond the coding interface. According to this approach, and as far as coding requirements are concerned, videotex and Teletext are decoupled, and both are decoupled from teletex. Likewise, the Antiope and Viewdata systems are decoupled. Thus, they may develop independently, the choice between them for any country (if such a choice has to be made) may be determined on grounds other than character coding, and the codes for each may be optimized for its own purposes.

Videotex and Teletext are characterized by five factors:

- need to minimize terminal costs;
- special error control needs (as mentioned briefly, above);
- special colour controls, and picture drawing capability;
- need to minimize number of transmitted characters; and
- for Antiope, the aim to exploit the use of Transpac and similar packet-switched services.

These have a substantial impact on the character coding arrangements. Although other arrangements are possible, the connexions shown in fig. 1 provide communication between different types of videotex or Teletext systems (and all others), whether in the public or private sectors, via the virtual alphabet in the general networks. Likewise, office-type videotex terminals might preferably be made to communicate in the virtual alphabet, i.e., with the coding interface at the terminal. This would simplify general inter-communication, and especially inter-working with telex.

### GRAPHIC REPERTOIRE OF VIDEOTEX

The requirements for the graphic repertoire for videotex and Teletext are somewhat less than for teletex and general text communication. Furthermore, in the interests of the economic production of the character generators within the terminals, it is suggested that, rather than slavishly implementing all the accented letters reviewed in the CCETT report, some discretion should be used in making a selection... to meet the needs of most users, to be adequate for minority groups, but not to burden everyone with undue overheads.

It has been found that these needs can be met by four regional variants, made of a primary set based on ISO 646 together with accented letters as composite graphics.

## REGIONAL SUBSETS

The suggestion that regional subsets should be 'recognized' aims to make the repertoire of accented letters more manageable. The objective is to provide a set of accented letters which, as composite graphics, can readily be fitted into an 8-bit code table where it is appropriate within the DTEs, and thus do not present users with an unfortunate 'overhead'; yet they serve for communication in all the languages of a region.

The grouping of languages to make such regions will require further consideration, being influenced by factors such as:

- the form of the languages, and their roots;
- the magnitude of trade and commerce between the countries;
- minority groups;
- the numbers of people using each language;
- geography; and
- educational and teaching requirements.

In the code table (see fig. 3) there is space for about 31 pairs of accented or special letters... assuming that both capital and small letters are provided. This is a critical constraint on the number of languages that can be included within any one region. It is suggested that French, German and English can be provided for in each regional subset, as major international languages. The following regional subsets are suggested:

- 1 - Western region: Includes all languages in an area bounded by Portugal, Italy, Switzerland, Germany, Finland and Britain.
- 2 - Scandinavian region: Includes Danish, Frisian, Faroese, Finnish, Greenlandic, Icelandic and various orthographics of Lapp, Norwegian and Swedish.
- 3 - Czech, Slovak, Slovene, Albanian, Hungarian, and Yugoslavian languages
- 4 - Polish, Estonian, Lithuanian and Wendish
- 5 - Lettish, Polish, Lithuanian
- 6 - Romanian Turkish

## USE OF SHIFTS

ISO 646 defines a 7-bit code; ISO 2022 specifies how several 7-bit codes may be related together as 8-bit codes, and how inter-working can be attained between 7-bit and 8-bit environments; while ISO 4873 provides the basic structure of an 8-bit code. By using these standards, conversion is always possible between such 7-bit and 8-bit codes.

In an 8-bit code table, columns 0 and 1 contain the C0 set of control functions; columns 2-7, the G0 graphics; columns 8 and 9, the C1 control functions; and columns 10-15, the G1 graphics. When used in a 7-bit environment, after the Shift In character, all subsequent characters are deemed to be from the G0 set... until the Shift Out character, signifying that the following characters are from the G1 set. These are locking shifts, which means that each remains operative until the other occurs.

(Mr McGREGOR ROSS goes on to discuss 'a potentially serious problem' concerning the coding of the two non-locking shift characters SS2 and SS3.)

## ERROR CONTROL

Some forms of error control affect the use of the eighth bit in each character, and thus impact on its use for encoding the control functions and graphics.

(Mr McGREGOR ROSS examines 5 different types of error control.)

## CALL SET-UP AND NETWORK SERVICE MESSAGES

Call set-up imposes special restrictions and requirements on character sets and coding. On the one hand, the utmost generality is required; there must be no possibility of ambiguity or confusion; the simplest equipment must be provided for. On the other hand, only a restricted set of characters is needed. For text communication, it would therefore appear to be appropriate to use only a restricted subset of IA5 for call set-up, and for service messages between the network and terminals or computers connected to it. Fig. 4 presents a 7-bit table that might be used for call set-up and service messages.

	0	1	2	3	4	5	6	7
0	NUL		SP	O		P		p
1			!	1	A	Q	a	q
2			"	2	B	R	b	r
3			#	3	C	S	c	s
4				4	D	T	d	t
5	ENQ		%	5	E	U	e	u
6		SYN		6	F	V	f	v
7	BEL		'	7	G	W	g	w
8	BS	CAN	(	8	H	X	h	x
9			)	9	I	Y	i	y
10	LF	SUB	*	:	J	Z	j	z
11		ESC	+	;	K		k	
12			,	<	L		l	
13	CR		-	=	M		m	
14	SO		.	>	N		n	
15	SI		/	?	O		o	DEL

Fig. 4 Suggested 7-bit table for call set-up and service messages

## IMPLEMENTATION IN GENERAL TEXT COMMUNICATION EQUIPMENTS

It may be useful to reiterate four of the key ideas of the suggested scheme:

- There is a single transmitted code, which is a superset.
- The transmitted characters and character-sequences may be limited in number to those required to be recognized by a particular DTE.
- The coding arrangements within any DTE may be decoupled from the network, and are optimized for the DTE.
- The sub-components within a DTE may be decoupled from each other.

In order to make implementation matters manageable, and especially to meet the objective of optimizing the ergonomic aspects of the use of equipment, some further ideas are used:

- 1 - The capabilities for receiving may differ from those for sending. We call this send-receive asymmetry.
- 2 - The repertoires of graphics and control functions implemented in a DTE will almost always be a subset of those of the virtual alphabet.
- 3 - However, it is an aim that any terminal should be able to respond meaningfully to every recognized character or sequence that is received.
- 4 - This is eased by exploiting three further ideas:
  - (i) Approximate rendition, e.g., barred Os would be printed as single graphics in Denmark/Norway, but printed as the letter O with a solidus elsewhere.
  - (ii) Fallback, e.g., an A carrying a tilde can fall back to an A with a bar on top, or even to a simple A in telex; and the function Bold could fall back to Underline or even to normal presentation.
  - (iii) If a received character or sequence cannot be dealt with, it should be treated as Substitute.
- 5 - Keyboards should be designed to suit the needs of the user. Most often, they will provide only for own-language sending, but slight extension of their facilities could provide foreign language or multilingual capability.

## FALLBACK TO MORE RESTRICTED EQUIPMENT

The two concepts of the coding interface - at which conversion may be carried out - and fallback permit inter-working between the virtual alphabet and equipment with more limited capability... and hence inter-working, insofar as the more limited equipment is able, between it and any other text communication equipment.

For transmission, there is direct equivalence between the preferred 8-bit form of the virtual alphabet, and a 7-bit 2-shift form, the characters from columns 8-15 being called by a single shift SS2. However, in certain implementations it is desirable to encode a limited number of extra graphics, and especially a few accented letters as composite graphics, in a 7-bit code table. It is visualized that the first choice for these would be the positions in the code table following Z and z.

There is a big family of terminals, characterized by the Teletypewriter model 33 and 'teletype compatibles' for which the scroll mode of the virtual terminal protocol has been advised. It is visualized that inter-working between the general virtual alphabet and these terminals could be effected by converters probably associated with the PAD (packet assembler/disassembler) in a network. Transmission between the converter and terminal would be in a code to suit the latter. It is probable that accented letters might lose their accents, and there might be a relatively large number of 'Cannot Understand' graphics.

Inter-working with telex and similar telegraph systems is important because:

- (a) telex and telegraph terminals are very numerous, and have world-wide coverage; and
- (b) CCITT are interested in inter-working of telex with teletex and videotex.



## PROPOSALS FOR FURTHER WORK

We have noted items that might be considered for further work. These include:

- 1 - Specific character coding proposals for Euronet and Community countries;
- 2 - Development of a printer/typewriter mechanism;
- 3 - Development of British Viewdata and of picture-drawing capability;
- 4 - Proposals for formats of pages to expedite interchange;
- 5 - Typestyles for text communication based on sound typographical practice;
- 6 - Development of micro-circuits and graphic generators;
- 7 - Unified facilities for structuring, manipulation and interrogation of files;
- 8 - Inter-working with virtual terminal protocols, and development of these;
- 9 - Facilities to utilize concepts of open system inter-connexion and open data interchange in text communication;
- 10 - Making certain CCITT Recommendations meaningful;
- 11 - Call set-up proposals;
- 12 - Standardization support;
- 13 - Proposals for non-Roman alphabets;
- 14 - Investigation of keyboard innovations; and
- 15 - Testing station and procedures.

## LECTURE: Technological Environment

*Mr. M. Roetter, A.D. Little, Paris*

I would like to begin with the quotation from Saint Augustine: "God will not suffer Man to foresee the future, for if he were to perceive the miseries to befall him, he would despair, and were he to recognize some future glory, he would grow lazy and complacent." I hope that, in what I have to say, and in what is said by the others at this conference, we shall avoid both despair and complacency... neither of which is appropriate at this time.

What I wish to present to you, quite briefly, is an overview of some of the interesting developments in terms of telecommunications and data processing technology, terminals and networks, which have to do with videotex and related services, and with the issue that has already been raised of the integration or merging of videotex into a whole range of services.

Let me begin by talking about transmission services and local distribution systems. A couple of themes that I shall be emphasizing throughout this talk are the partial competitiveness and the partial complementarity of these different systems. I shall show that the question of whether or not a particular technology or implementation of a service turns out to be competitive or complementary depends, of course, upon one's point of view: i.e., whether one is a PTT, a manufacturer or a user.

Local distribution systems (see fig. 1) reach the end-user as both one-way and interactive services, and I would like to first mention the subject of cable television. In contrast to the USA and Canada, and to some extent Japan, there is very little activity in CATV distribution systems in most of the major European countries. This is a consequence of quite deliberate decisions which have been made, not to permit the development of CATV networks. We believe that this is an issue that needs to be examined, for several reasons. From the point of view of the user, a CATV distribution network may be quite complementary to the use of a telephone network, and it may enable services with somewhat different characteristics to be offered: obviously, wider bandwidth services. It may also be competitive in the sense that there may be a PTT in charge of the telephone network, and another organization in charge of the CATV network, and they are both competing to offer services that use the same kind of programming and the same kind of data bases.

- . Interactive:
  - telephone
  - CATV
- . One-way:
  - broadcast TV/radio
  - satellite
  - physical media

Fig.\_1 Local distribution systems

- . telephone network
- . satellite links
- . data networks
  - circuit switched
  - packet switched

Fig.\_2 Long-haul transmission alternatives

In terms of one-way local distribution systems, physical media must be included, because there are a lot of services that can be distributed, not only by means of traditional newspapers, but also through the use of cassettes, for example. People who own so-called personal computers may prefer to obtain these cassettes, maybe by renting them; rather than to rely upon telecommunications networks. I would also like to draw your attention to satellite systems, which I shall be coming back to later.

Now, what are the long haul - or long distance - transmission alternatives? (See fig. 2.) Here too, we find quite a variety of possibilities. The telephone network is very well known. Then there are various kinds of data networks, like Euronet. And there's also the possibility of using satellite links. One of the particular aspects of satellite links that is of great interest is of course their inherent broadcast capability... so they may provide an effective means of keeping up-to-date a large number of dispersed data bases. A great deal of attention is being paid to satellites both within Europe and outside. Quite frankly, when one observes everything that has been said and written about satellites, it appears to be a technology that has been greatly overrated. Let me deal in particular with direct broadcast satellite systems, for which several projects have been discussed. There are some obvious advantages to satellite direct broadcasting. One can avoid some of the problems associated with terrestrial frequency congestion. One does not have to put large numbers of cables in the ground. One can in principle implement the system very rapidly, and cover every part of a national, or indeed international, territory. However, there are some severe limitations. Some are technical limitations, and others are limitations in terms of the services that can be provided. For example, there's the eclipse problem. It's very difficult to have programmes around midnight... which is a great shame for those of us who like watching midnight movies! The most severe objection, however, to satellite direct broadcast systems is that they are not economic, and it is generally true that it is very hard to justify, on purely economic grounds, a single service satellite. What needs to be done, if satellites are to be justified, is to devise interesting combinations of services which can be offered over this very expensive transmission medium. Otherwise, one is in effect installing a satellite for non economic reasons, which may be to do with prestige, or which may just be a conscious decision to subsidize the provision of services to some people in remote areas. But it's very important to realize what one is doing if one makes the very large investment involved in a satellite, because this large investment is a significant drain on funds, and therefore has an influence, obviously beneficial, on those people who want to sell satellite communications equipment, but not necessarily so beneficial for the consumer.

The second technology that should be mentioned, for transmission, is fibre optics. Again, this is a technology which has received much attention in recent years. We believe that fibre optics communications systems are indeed a very interesting technology, potentially, for wideband interactive local distribution systems in the future. But we feel it also necessary to point out that, when one looks at the possibility of implementing such systems with fibre optics technology, it is necessary to carry out a thorough systems analysis which goes well beyond attempting merely to compare the cost of fibre optics and copper cable. There are some significant technological limitations at the moment, such as the unavailability of an economic and effective optical tap... which means that the use of this technology at the moment, as for example in the Hi-Ovis project in Japan, is only justified on an experimental basis. The interest in this technology - optical communications in general - goes well beyond just communications, and it is justifiably one of the technologies that has been judged worthy, by the Japanese government, of massive long-term research efforts. But at the moment, the question of whether one uses fibre optics or coaxial cable is not fundamentally a technological question, because it is hard to conceive of services which can be offered on one and not on the other.

Let me now turn to terminal equipment, which is very important. Here too, of course, we observe that a lot has been written and said about micro-processors, digital logic and memory in general. However it is true - as Mr APPLEYARD pointed out this morning - that, currently, there is a significant mismatch in cost, particularly for the domestic market, between inexpensive powerful logic and peripheral equipment for data storage, entry, output and display. If we look at some of these sub-elements in terms of displays, we observe that there has been a tremendous amount of development throughout the world in attempting to develop alternatives, particularly flat screen alternatives, to the well known cathode ray tube. The fruits of these development efforts, up until now, have been extremely limited. There are some prospects that small-screen black and white liquid crystal displays will become available within the next five years. But for the most part, especially for large-screen displays, CRTs still have a long future ahead of them. In terms of non-volatile secondary storage, there is of course still some controversy concerning the future of magnetic bubble technology. I don't wish to go into this controversy in detail, because in fact it is rather irrelevant with respect to the objectives of the present conference. There are a number of technologies - such as videodisc - which make it almost certain, as far as storage is concerned, that we shall have most of the storage at the right kind of price that we shall need during the 1980s.

Finally, a few words about printers and keyboards. Printers are probably the most significant cost element that can be

conceived of, particularly in a home terminal, and one where it is perhaps hardest to foresee a big price reduction because of the substantial mechanical content. It's the same sort of problem encountered with videotape recorders. In addition to these technologies, I would like to mention in particular voice synthesis, word recognition and speech analysis. It seems likely that, as these technologies are developed - and there is a tremendous amount of work going on -, they will change significantly the ways in which most people regard computers. It is still true, as those of us who work with computers know, that for most people, dealing with a computer is something strange. And one can speculate that, when it becomes possible to talk to a computer, and for the computer to talk back, either this will make computers even more strange, or (it is to be hoped) it will make people's dealings with intelligent machines that much easier. When one looks ahead at the possible expansion of videotex services, then certainly the inclusion of voice response and voice input is potentially something of great significance.

Fig. 3 lists some of the ways in which videotex services could be organized. The possibilities involve PTTs, independent information providers, broadcasters, CATV operators and private publishers. There are many other potential partners. In order to discover what is, after all, the ultimate arbiter, i.e., the opinions of the market-place, it is necessary to have an environment in which many things can be tried and in which, therefore, a certain number of failures are inevitably to be expected.

There is an expression that sends shivers down the spines of the union representatives in some PTTs: electronic mail. Now my company, like many others, finds that the mail service, especially for international mail, is becoming increasingly unreliable, and there is great interest in trying to find substitutes for this service. Now, videotex services provide the means of sending messages which would otherwise be sent by mail, and I understand that the British Post Office has envisaged the connexion of Prestel to the telex services. This is clearly something which could be used by residential as well as business users.

Let me now make a few comments about the situation outside Western Europe, concentrating upon the three major advanced nations in this domain. The USA, of course, has information services - including those that use telecom networks - which are in many respects further developed than those which exist in Europe. This perhaps explains why there has been, until recently, relatively little interest in videotex-type services. The USA also has a manufacturing industry which is doing all kinds of things... in the realm of personal computers, in the realm of semi-conductors and so forth. In the USA there is a tremendous explosion of new ideas which are being brought to the market-place. Some of these are trivial, obnoxious even! But the significant thing about it

Fig. 3 Videotex and related systems: selected service concept examples

<u>Service Provider</u>	<u>Transmission Media</u>	<u>Keyboard</u>	<u>Ancillary Equipment</u>	<u>Relative Terminal Cost</u>
PTT plus independent broadcaster	telephone	full alphanumeric	special terminal	1
CATV operator	full channel TV 2-way CATV	numeric & special functions numeric & special functions	special terminal special terminal	1
private publishers	physical delivery cassette tape	full alphanumeric	home computer, printer, cassette, tape	10

Note: assume colour TV and VRC are sunk costs

is that almost anything that can be conceived will be tried by some maniac somewhere! Therefore, one can look at the USA and get a feel for the market... which is harder to do in the more closely regulated environment of Western Europe.

In Canada we have a somewhat different situation. Cable television is much more advanced, and there is a very interesting mixture of private and government initiatives. I'm glad that Telidon, the people from the Department of Communications, are here today. They are of course actively participating in most of the discussions taking place on videotex in Europe and in the USA.

Japan is in an interesting situation. The Japanese television industry, for example, is one that, quite correctly, is regarded with growing apprehension by European manufacturers. And the Japanese semi-conductor industry is similarly regarded in the USA. At the same time, as I pointed out in a remark I made this morning, in terms of telecom-based services, Japan has not in fact produced, up until now, anything of tremendous interest.

So, the situation outside Western Europe can be both a help to Europeans, in being able to learn from successes and mistakes there, and also a threat, for industrialists in particular, who must watch out for foreign penetration into established markets or new markets. I would suggest that, if European manufacturers are slow in adopting new ideas, one might give development contracts to Japanese manufacturers, who would not be slow, in an attempt perhaps to stimulate more conservative European judgment.

Mr McGREGOR ROSS has made an excellent exposé of some of the issues concerned with standardization and compatibility... and I would just like to add a few remarks to this. It seems to us that the attempt to adopt a single common videotex standard is - as Mr McGREGOR ROSS said - probably unnecessary, and certainly politically unfeasible. There are obvious advantages, in an academic sense, to the adoption of such a standard... but there are also obvious disadvantages. There is, for example, the premature cut-off of innovation; the added cost to some users of features which they are not really willing to use or which they would use infrequently; significant further delays in the availability of the service (i.e., the mania of the engineers who always want to improve a product, so they never get one to market); and the delays caused by continuing political disputes. We believe that there is much of value to be learnt from an approach that is already quite widespread in certain data base and teleprocessing networks. These networks, notably in the USA, incorporate translators which are capable of accommodating therefore, within a single network, a tremendous variety of terminals... and provided that certain care is taken at the outset, it is certainly possible to make allowance for the access to a data base in France from, say, a terminal in the



UK or West Germany... as Mr McGREGOR ROSS has suggested.

Let me therefore move on to what we see as being some of the important recommendations to make to the European Community and, in particular, to the Commission. We believe, first of all, that it is not appropriate, clearly, for the Commission or for the Community as such, to get involved in everything. Certain general conditions should define what it is that the Community can usefully do. In the first case, there should be an international rôle, for we are dealing with a situation which falls outside the capability and competence of a single national government. And the second useful guideline is that there should be an insufficiency of initiatives by other concerned parties. Now, against these two guidelines, there are a number of specific steps and general lines of action which, we believe, would be fruitful.

First of all, there is a rôle that the CEC can play to ensure future system inter-operability, i.e., there should at least be common standards of documentation for new developments, and rules for developing protocols for display communications and control. As PA has suggested, there might be a test centre, where manufacturers might obtain advice on the appropriateness of the developments they are pushing.

The second point that I think is important - and here I rejoin Mr BARNES, who laid stress upon personal computers - is that videotex terminals, as they are now being conceived and developed, are by no means the only or dominant type of terminal which will eventually make use of video services or the services that may develop from videotex. Now, it is unfortunately the case that the traditional way in which one gets terminal equipment approved by PTTs and marketed in most European countries is a major inhibition to innovation, given the current state of the art... and therefore something must be done to change the situation, or it will turn out that people who have bright ideas, in Europe, will be able to market them first in the USA or elsewhere. It is utterly ridiculous, for example, to look at the level of detail which some PTTs exercise upon the types of equipment which can be connected to their networks, going down, for example, to some of the ways in which individual components get packaged. This simply does not correspond to the pace of innovation which is now possible. There is one note of caution which must be sounded here. Clearly, if one country was suddenly to liberalize its market, and nobody else did it, there would be a significant risk of disruption of that market in a way that would be considered (rightly so) as unjustified by the current suppliers to it. Therefore, we have here an issue that is properly dealt with at the Community level.

We believe that it is possible for the Community to stimulate the development of videotex-emulated services by a variety of means. Firstly, the Community can act in a sense, itself, as an information provider... and a particular suggestion has

been made: Why not use Euronet? That seems to us to be an excellent idea. Secondly, there could be Community funding of new applications developments. Here again, encouragement seems to be needed to suppliers of services and hardware, and one way of encouraging people is to cover some of their development costs. And the third point which, I think, is of particular interest is to have the Community, or rather its institutions, become a major user of videotex or other advanced communications services. I can only speculate, with some interest, what might be the attitudes of parliamentarians at the national and European level, were they to have much more day-to-day access to some of these new services, since - unfortunately, in Europe, as in the USA - most individuals in politics do not have a technical background.

Finally, we recommend that the Commission itself takes an active rôle - alone or jointly with other interested bodies - in developing projects for field research into appropriate new communications concepts which, as I pointed out, have been either neglected to some extent in Western Europe, or seemed to have been approached too much from a one-sided point of view. I noted in particular, here, interactive CATV networks, where some of the smaller countries in the Community - such as Belgium, for example - may provide more fruitful grounds for experimentation than some of the large ones. And we took a hard look at satellite broadcast systems which - as I said, in our judgment - are extremely hard to justify economically if they only provide the single service of distributing television.

To summarize then, very briefly, videotex is only one of many developments in the broad field of information technology. This is a technology which is making possible many types of new services, the individual markets for which are extremely difficult and, indeed, impossible to predict... which implies that it is necessary to have a much more open and experimentally-minded atmosphere for exploring these markets, than has existed up until now in the countries of the Community... although there are a few signs that such changes are occurring. We believe that the chances of success can be enhanced by actions and approaches adopted at the Community level, which would be designed to serve the interests of the users in the broadest sense, and also the interests of industry based in Europe, which faces significant challenges from industry based outside of Europe.

**TEXT: Videotex – Competitive and  
Complementary Technologies**

Summarized extracts from the study report:

*A.D. Little, Paris*

THE FOLLOWING TABLES AND TEXT HAVE BEEN EXTRACTED FROM  
THE BEGINNING AND THE MIDDLE OF THE A.D. LITTLE REPORT.

SUMMARY SHEET OF VIDEOTEX AND RELATED SERVICES

136

<u>SYSTEM</u>	<u>ORIENTATION</u>	<u>TRANSMISSION</u>	<u>CONTENT</u>
Qube (USA)	Home	2-way CATV	CATV, shop-at-home, referenda, pay TV
TOCOM (USA)	Home	2-way CATV	CATV, security services
KSL-TV (USA)	Home	Broadcast TV	News, information in teletext format
Micro TV (USA) (1)	Home	Multipoint Distrib.Service	News, information teletext format
Videotex /VISTA (CANADA)	Home	Telephone	News, information, entertainment
Prestel (U.K.) Canadian	Home, Business	Telephone	News, information, entertainment
Cablesystems (CANADA)	Home	CATV (2-way?)	News, information in teletex format
Telidon (CANADA) (2)	Home	Telephone, CATV	Unspecified-R&D program
TAMA (JAPAN)	Home	2-way CATV	TV, memo, home fax, voting tests
Hi-Ovis (JAPAN)	Home	Optical fibre (2-way)	CATV, text/photo info retrieval
Elie (CANADA)	Home	Optical fibre	Telephone, TV, radio
COMPUCOM (USA)	Home	Telephone	Information services, games
CAPTAINS (JAPAN)	Home	Telephone	News, information
GTE Test (USA)	Home	Telephone	Unspecified-R&D program
Ceefax/ORACLE (U.K.)	Home	Braodcast	News, information in teletext format
TELETEL (FRANCE)	Home, Business	Telephone	News, information, entertainment
BILDSCHIRMTEXT (W. GERMANY)	Home, Business	Telephone	News, information,entertainment
TELSET (FINALND)	Home, Business	Telephone	News, information, entertainment
REUTER /IDR (USA)	Business	CATV	Financial news
TECHNOTEC (USA)	Business	Telephone	Want ad system
NY Times Infobank (USA)	Business	Telephone	Information, new summaries
Dow Jones			
News/Retrieval (USA)	Business, Home	Telephone	Financial news, related stories
FYI News (USA)	Business	Telex/TWX	News, information summaries
Green thumb (USA)	Farmers	Telephone	Weather, market information
Data Vision (SWEDEN)	Home, Business	Telephone	News, information, entertainment
Videotext (W. GERMANY)	Home	Broadcast	News, information in teletext format
Text TV(SWEDEN) (3)	Home	Broadcast	News, information in teletext format

(1) Cancelled early 1979;      (2) Department of Communications

(3) Other teletext services include Biblos (Belgium), Teletext (Denmark), and Teletext (Netherlands)

INTERACTIVE HOME-ORIENTED SYSTEMS

<u>SYSTEM</u>	<u>TRANSMISSION METHOD</u>	<u>TERMINAL</u>	<u>STATUS</u>
Prestel (British Post Office)	Telephone-1200 bps downstream, 75 bps upstream	Modified TV or TV adaptor, with telephone	Almost 100,000 "pages" in database. In U.K., 200-300 users in beginning of market test, going to 1500 depending upon availability of terminals. Commercial service started Spring 1979.
Videotex/VISTA (Bell Canada, Torstar, Southam Press) CANADA	Telephone	Modified TV or TV adaptor, with telephone	Database has 2000 pages. In Toronto, 25 terminals circulating among information providers. Market trial scheduled for 1980.
Character and Pattern Telephone Access Information Network Systems-CAPTAINS (Nippon Tel & Tel.), JAPAN	Telephone	TV adaptor, with telephone	Projecting 100,000 pages in database but current status unknown; scheduled market trial in Tokyo with 1000 terminals in 1979; 100 companies agreed to participate as information providers.
Telidon (Canada Department of Communications) CANADA	Telephone, CATV	TV adaptor, with telephone	Experimental technical develop project. Terminal devices to be tested in Videotex VISTA and Canadian Cablesystems.
GTE test U.S.A.	Telephone	TV and adaptor	Experimental R&D on Prestel-type system with reports of 1980 market test plans
Teletel (French PTT & Broadcaster TDF)	Telephone*	Modified TV or TV adaptor, with telephone	Trial service for 3,000 users in Velizy (near Paris) in 1980
Bildschirmtext (Deutsche Bundespost)	Telephone	Based on Prestel initially	Trial services in 1980 in Berlin and Duesseldorf (subject to some regulatory uncertainty)

\* Note also PTT project for low-cost mass-produced videotex terminal  
to replace printed telephone directory-price around 400 francs, trial set for 1981

INTERACTIVE HOME-ORIENTED SYSTEMS (cont.)

<u>SYSTEM</u>	<u>TRANSMISSION METHOD</u>	<u>TERMINAL</u>	<u>STATUS</u>
Hi-Ovis Higashi-Ikoma Optical Visual Information System (MITI) JAPAN *	36 optical fibre, space division multiplex	TV, Keypad	1978 test connected 160 homes for 2-way CATV, text/photo information retrieval
Elie, Manitoba (Canadian Telecommunications Carriers assoc. & Can. Govt.) CANADA	Fibre optical cable	TV, telephone	5-year program, 150 households, an- nounced Feb. 1979; system installation to take 2 years; services: telephone, TV, radio and "special"

\* Ministry of International Trade and Industry.

INTERACTIVE HOME-ORIENTED SYSTEMS (cont.)

<u>SYSTEM</u>	<u>TRANSMISSION METHOD</u>	<u>TERMINAL</u>	<u>STATUS</u>
Qube (Warner Communications) U.S.A.	2-way coaxial cable system with computer polled subscriber terminals	TV & Box with program selection and five response keys	Operational in Columbus, Ohio, with 25,000 + subscribers, providing shop-at-home, referenda, security services and pay TV ; \$11/month plus program selection charges
139 TOCOM, Inc. U.S.A.	2-way coaxial cable systems with computer- polled subscriber terminals	TV & wired subscriber dwelling	Operational in several "new towns" and as add-on to CATV system in Dayton, Ohio, providing home security services; monthly charge in Dayton is \$ 16/month for security services
TAMA Coaxial cable information system (Ministry of P & T) JAPAN	2-way coaxial cable with computer polled subscriber terminals; 27 ch. downstream, 5 ch. upstream	TV, keypad various other devices depending on experiment (memo-fax, n'paper fax, B&W TV)	Jan.1976 - Oct. 1977 experiments in Tokyo suburb serving up to 500 terminals for CATV options, 30 for memo copy, 40 for automatic telecast B&W TV, 20 for fax newspaper, 80 for referenda and still picture request

HOME-ORIENTED SYSTEMS: NON-INTERACTIVE

<u>SYSTEM</u>	<u>TRANSMISSION METHOD</u>	<u>TERMINAL</u>	<u>STATUS</u>
Ceefax/ORACLE (teletext systems of BBC and IBA) U.K.	Vertical blanking interval in broadcast TV channel	Modified TV or TV plus adaptor (teletext/viewdata combinations are available)	Several hundred constantly updated "pages", cyclically re-broadcast; advertisements carried on IBA's ORACLE; may be 10k terminals in use
KSL-TV U.S.A.	Vertical blanking interval in broadcast TV Channel	TV plus adaptor	Test of teletext system in Salt Lake City, with Texas Instruments
Infotext (Micro TV) * U.S.A.	Multipoint Distribution Service (MDS)	MDS receiver, TV, decoder	Test of teletext in Philadelphia over MDS system
Canadian Cablesystems CANADA	CATV system		Government (CRTC) approval requested for teletext service in Kitchener, Ontario

\* cancelled early 1979



BUSINESS-ORIENTED SYSTEMS

<u>SYSTEM</u>	<u>TRANSMISSION METHOD</u>	<u>TERMINAL</u>	<u>STATUS</u>
Reuter/IDR U.S.A.	CATV channel-non- interactive	CRT, decoder, keyboard	Financial news service over Manhattan Cable channel; user keys in desired page from set being cyclically cable- cast; service extension to other cities planned via satellite
Technotec (Control Data) U.S.A.	Telephone-via CYBERNET network	Teleprinter or computer terminal	Keyboard search system for patents, sell/buy programs or components; \$100/ yr/listing; \$15/search; in 1978-1800 entries, 1400 subscribers
New York Times Information Bank U.S.A.	Telephone	Teleprinter or computer terminal	Abstracts or news from <u>NYT</u> and other publications; 1.4 million entries back to 1969; \$80-\$110/hour; 5-day backlog on <u>NYT</u> stories, longer for others
Dow Jones News/ Retrieval U.S.A.	Telephone	Teleprinter, computer terminal, home computer	90-day file on current news articles from DJ News service, <u>WSJ</u> , <u>Barrons</u> ; items on 6000 companies; \$50 month \$40/hour; rate for home computer access: \$50 plus \$3/1st min., \$0.50/ additional min.

BUSINESS-ORIENTED SYSTEMS (cont.)

FYI NEWS (Western Union) U.S.A.	TWX or Telex	Teleprinter	New items, commodity prices, weather, available to TWX or Telex subscriber for cost of network service usage
Green thumb (U.S. Dept.of Agriculture and Dept.of Commerce) U.S.A.	Telephone	TV, adaptor (modem, microprocessor, storage, ROM, character & RF generator) and telephone	Pilot project by Univ. of Kentucky planned 1979-1981 in 2 Kentucky counties; 100 terminals to be linked to county extension service; data selected via keypad, xmitted to terminal and loaded (up to 4k characters) phone disconnects and data (weather, market info) displayed on TV; Political opposition exists to government role in service to farmers.
Antiope-Bourse (FRANCE, TDF)	Broadcast TV -non interactive	TV, decoder	Stock exchange data, opened experimentally in May 1977, public service in January 1979
Antiope-Meteo (FRANCE, TDF)	Broadcast TV -non interactive	TV, decoder	Weather reports and forecasts to selected subscribers, service opened January 1979

## SERVICE COMPLEMENTARITY AND COMPETITION

### (a) Business Market

An interesting question for Western Europeans pondering the future of Videotex and Videotex-related services is why there should have been until now considerably more initiative and action taken in this domain in Western Europe than in the U.S. At a first and superficial glance, this situation would seem to be an exception to the oft-lamented lag or lack of entrepreneurial initiative in Western Europe, as compared to the U.S., in the commercial development of new electronics-, telecommunications-, and data processing based products or services. Several hypotheses may be put forward:

- Indeed, Western Europe has stolen an entrepreneurial march on the U.S., and the monopoly position of PTT's in this instance has the positive effect of enabling a new, nationwide telecommunications, data-related service to be offered more rapidly than the fragmented, regulatory environment of the U.S. permits.\*
- The development of Videotex services is only at an embryonic stage, and it is more than likely that they will develop more rapidly in the U.S. than in Western Europe, as has happened before with the commercial exploitation of other Western European inventions.
- Much of what Videotex services can provide, at least for business users, is already available in other forms in the U.S. to a far greater degree than in Western Europe, hence the interest in the U.S. in what Videotex services can offer is much less.

\*ATT is not permitted to offer data processing services, for example, and spends much time and effort arguing that its new data-oriented services and products do not violate this restriction.

We believe that there is some truth in all of these three hypotheses. For example, in certain respects the British Post Office has acted in a more entrepreneurial manner than its traditional style in developing the Prestel service (the relatively rapid opening of a public service without very lengthy non-commercial trials ; the decision to allow modems to be built into the terminal). Secondly, should the commercial development of Videotex services in several major European companies be delayed by lengthy discussions and controversies involving powerful, established interest groups (PTT's, broadcasters, the press, sometimes local and central governments), then indeed the vaster, more experimentally-minded U.S. market may experience a more rapid growth of Videotex than Western Europe. Finally, and of greatest direct relevance to this discussion, the general infrastructure of information services in the U.S. is broader and more effective than in many European nations. The relatively low prices and ready availability both of telecommunications-accessed data base services, as well as of information publishers (of which the U.S. Federal Government is one) reduce the apparent need for new initiatives in information services in the U.S., as compared to the less information-rich societies of Western Europe. Coincident with the great surge in interest in Videotex services in the U.S. are several initiatives by U.S.-based telecommunications common carriers and data base operators to strengthen their position in European markets by negotiating agreements for access to their services with European PTT's. There is inevitably scope for competition between European PTT's as to which one will provide the major gateways for access to U.S.-based services, just as European airports compete to be gateways for trans-Atlantic air travel.

We believe then that the business user demand for Videotex services will be markedly affected by the ability of Videotex to offer services comparable to those now available from U.S. data base companies. As a corollary, the chances for European data base services to compete with their U.S. counterparts could be enhanced by their interconnection with Videotex infrastructures.

(b) Consumer Market

The dynamics of the consumer market for Videotex services are very different from the business market. The possible evolution of Videotex and Videotex-related services for the consumer market has to be looked at within the very broad context of how consumers spend their discretionary income. Videotex hardware and services are competing for the consumer against a wide range of other household electronic products, some of which may, at least eventually, contribute to or participate in Videotex (e.g. home computers), while others do not (e.g. tools). Further, the consumer may choose between buying Videotex hardware, or say taking a safari vacation in Kenya.

There are several characteristics of consumer electronic markets which observation of current and past behaviour permits us to identify.

Firstly, the development of markets for consumer products tends to follow an evolution whereby these products progress from an experimental or embryonic stage, to a stage where they are a luxury product, until, if successful they become accepted as a standard or "essential" element of any normal household. This last stage, which of course is not reached by all products, may occur at any time when the penetration of households by the product lies somewhere in the broad range of 10 to 50 %. The price of the product is a key factor, naturally enough, in

influencing whether or when the product reaches the "standard" stage. Consumer expectations based on experience are that the prices of all electronics products are bound to fall, which can create difficulties where the majority of the cost of a product lies in non-electronic hardware, whose costs are expected, at best, to stay constant (e.g. video cassette recorders). The price barrier for an item to become "standard" seems to lie, in Western Europe, between 600 - 900 EUA.

Secondly, the growth of a market for a consumer product can follow one of a few broad tracks. On a very fast track, e.g. electronic calculators, penetration of well over 50 % of households is readily obtained in 5 years. On a medium-speed track, e.g. colour TV's, penetration of households up to the 30 - 50 % level will build up over 10 - 12 years. There are also examples of slow track products which fail to become "standard" items, and of course products which never achieve any significant commercial penetration at all.

Thirdly, we note that as the societies of Western Europe, the U.S. and Japan have become more affluent, households tend to add new products as they come along, rather than to operate in a substitutive mode. Affluence allows the consumer to devote resources to items which may only be used occasionally. This phenomenon is particularly evident in the many articles for sport which have found great favour (skiing, tennis, sailing, etc .)

Fourthly, there is a growing flood of new consumer electronics products coming onto the market, based upon the capabilities of inexpensive, programmable, large-scale integrated circuits (microprocessors). These products include many that are trivial or obnoxious to some tastes, as well as many that are tremendously entertaining and even instructive and intellectually stimulating. We have noted from experience in the U.S. (and there is no reason to expect anything different in Western Europe), that the vast majority of today's adult consumers find it very difficult

to operate anything but the simplest keyboard (say one comparable to a push button telephone set). Children and adolescents, on the other hand, who have grown up in schools with access to computers via keyboards, have no such problems. The implications for Videotex, particularly enhanced Videotex-type services are obvious, namely that this market, like the markets for many other consumer electronics products, is quite likely to be driven by the demands of youth (even where the adults pay). Furthermore, the environments in schools and the experiences which children and adolescents gain there, will influence the acceptability of Videotex and Videotex-related services in the home.

Finally, we note that Videotex and Videotex-related services fit into the triangle of Entertainment-Information-Communication which attracts a growing amount of consumer expenditures once more basic needs (food, shelter, etc.) are satisfied. Successful products, like radio and TV, are capable of catering to a variety of consumer desires, simultaneously or at different times. For example TV watching can be for entertainment, for education, or simply for the avoidance of boredom if there is nothing else to do. One of the basic factors in the design of Videotex and teletext services has been just to take advantage of the possibilities of multiple-purpose hardware, namely exploiting the TV receiver and telephone which most households have.

Several conclusions can be drawn from the above remarks. It is not likely that Videotex will become a mass consumer service unless (a necessary, but not a sufficient condition) the basic hardware involved costs no more than 75 - 150 EUA over the current prices of TV receivers. This conclusion has been reached many times elsewhere : it may be modified somewhat by imaginative marketing approaches following the British practice of renting TV sets. In addition, the development of Videotex and Videotex-related services cannot be viewed and analysed in an isolated manner but needs

to take into account the likely proliferation of micro-processor-based electronics products in the home in the 1980's and 1990's. These products will range in capability from simple (even trivial) gift items, to sophisticated games, video recording devices, and digital audio systems, up to home computer systems. Some of these products, at least the more expensive ones, will be competing, if they are primarily stand-alone, or non-telecommunicating items, with Videotex for discretionary consumer expenditures. Others, to the extent they can also participate in telecommunications-based services, may contribute mightily to the growth of Videotex. We note as an early example the service offered by Apple in the U.S. in conjunction with Dow Jones, which allows owners of Apple's home computer to access stock information by dialling a telephone number and waiting for the data to appear on the CRT. It is likely to be very important, then, that new programmable products in the home, as well as the relatively simple TV set-keyboard-decoder combinations of today, be allowed to access Videotex and Videotex-related services, if these are eventually to achieve mass penetration of households.



## IMPLICATIONS OF NEW COMMUNICATIONS SERVICES

### 1. INTRODUCTION

The role of new communications services both influences and is influenced by a variety of technical and industrial factors, as well as a broad range of complex legal, regulatory, social, economic and political issues. Videotex and related services fall at the junction of telecommunications broadcasting and the press (in terms of information delivery systems), and telecommunications, data processing, semiconductors, and consumer electronics (in terms of manufacturing industry). Videotex is not the sole result of the conjunction of these various manufacturing and service industries, nor is it the sole factor in the tangled web of legal, regulatory, and socio-economic issues which are being argued over as a consequence of the changing segmentation of economic and industrial activity which microelectronics and other new technologies are making possible. Rather Videotex inherits and to some extent exacerbates further the potential for dispute and confusion, particularly in the regulatory sphere, which the increasingly intimate interaction between communicating, and handling or processing information is bringing about. Being potentially a service with a major impact upon consumers, Videotex adds to these disputes a heavy dose of concern about the rights of, and benefits to consumers directly (rather than at one remove as in analyses of the impact upon industry alone) of alternative uses and abuses of, and regulatory structures for information handling, storage, and delivery.

In the following we identify and examine the important factors of a technical, regulatory, and socio-economic nature which will affect the course of Videotex development, and/or upon which Videotex services themselves may have a significant impact.

## 2. TERMINAL EQUIPMENT INTERCONNECTION

European markets for many classes of telecommunicating product continue to be very fragmented nationally, as a consequence of various PTT policies. Terminals are affected by this market fragmentation, particularly modems, facsimile and telex terminals and telephone sets. Some terminal equipment, particularly traditional data processing terminals, is largely unaffected by this problem, where clear interfaces exist with the PTT network. PTT procedures vary from country to country, but share several common features in that they are often lengthy, tend to favour national suppliers, and specify technical details at a level much finer (e.g. components packaging) than that of telecommunications standards. Thus it is extremely difficult to develop a Europe-wide product in many instances. A critical policy question for PTT's and other government bodies involved in issues of trade and competitiveness is thus:

- Should equipment interconnection policies and procedures be liberalised, and if so, how?

The advantages of liberalisation can be:

- User benefits from access to a greater variety of innovative products, brought rapidly to the market
- Creation of new opportunities for small (and large) firms with an innovative bent
- Establishment of a larger "domestic", i.e. Europe-wide, market for European products, to give them a comparable market base from which to compete against non-European (U.S., Japanese) competitors; this last potential advantage is of course only realized if several major European countries adopt comparable liberalisation measures at the same time.

The major potential disadvantage of a liberalisation of equipment interconnection procedures in Europe, particularly if done unilaterally by only one country, is that that country may be flooded by imports from the U.S., Japan, and elsewhere in Europe, if its own industry is not ready or is slow off the mark.

The issue of how to make the transition to a more liberal equipment interconnection policy is thus a far from straightforward one. We anticipate however that it will eventually come about, because it is becoming increasingly clear that PTT's are not structured so as to cope effectively with the flood of new types of telecommunicating product that are being developed, which business communications users will increasingly require if their overall operations are to be competitive. In addition, major national electronics manufacturers will wish to find domestic markets for new products which have excellent market growth prospects worldwide.

The longer the liberalisation of interconnection is delayed, the more users will suffer, and the more difficult it will be for any but the largest European multinational companies (which can afford to develop new products which have no domestic market) to be successful in the newly emerging communicating terminal equipment markets, against non-European competition.

### 3. INVESTMENT IN THE TELEPHONE NETWORK

Existing telephone networks have been engineered, in terms of their transmission, switching, and routing capacities, according to well-understood patterns of telephone traffic. In certain special circumstances, for example exchanges in the City of London, or an exchange in an area with a large time-sharing activity, traffic patterns can be sufficiently different from the norm that careful engineering is needed.

Now in the event that telephone-based Videotex services become important, two effects may be observed. Firstly, there will be a significant additional demand for telephone lines created, since, as noted in the PA Management Consultants report on the Videotex market, users are not likely to be willing to have their telephone service interrupted when using Videotex. Secondly, the patterns of traffic on these Videotex lines may be substantially different from traditional voice traffic, which will have important implications particularly for the engineering design of local telephone exchanges (for example the call handling capacity of the control system, and the degree of concentration included at any stage in the switching network). The consequences of failing to take these factors into account properly could lead either to excessive investment in underused telecommunications plant, or to a very low grade of service (high blocking probability) being provided to frustrated would-be Videotex users.

In the long run then, the success of Videotex services would lead to a substantial number of households having more than one telephone line (and also more than one TV set). The pace and pattern of PTT's investment in their telephone networks may, as a consequence, have to be notably different ten years from now than their current long-range planning indicates. It appears currently that PTT's hope that Videotex traffic patterns, at least residential ones, will be primarily complementary to typical voice traffic patterns, rather than competitive with them. Thus more revenues can be obtained with little or no increase in traditional telephone plant. This hope or expectation has yet to be tested and proved or disproved.

#### 4. TV BROADCAST SATELLITES

There is considerable current interest in Western Europe, and in particular in France and West Germany, in the use of satellites for telecommunications services other than long-distance telephony and point-to-point TV transmission, namely

for a range of business communication services and TV broadcasting. Direct broadcast TV satellites have been proposed for use in Europe, and the French envisage wideband digital links for business communication to be provided by satellite in a manner not unlike Satellite Business Systems' (SBS) proposal in the U.S.

The development of satellite services in Western Europe is complicated by the number of partly overlapping and partly competitive organisations which may be responsible for satellite development and/or operation, including national PTT's and their satellite organisation Eutelsat, and the European Space Agency (which includes more than Community members). The outlook is further dependent upon the outcome of the World Administrative Radio Conference (WARC) to be held later this year, which will deal with issues of frequencies for TV transmission among other responsibilities.

We intend to deal here with the impact of satellites upon TV transmission, since this will affect TV markets, to which Videotex and Videotex-related services are linked. We begin by noting that one of the reasons for an interest in satellite TV broadcasting is the shortage of frequency spectrum for the expansion of the number of TV channels by terrestrial over-the-air transmission. Satellites can ease this shortage in two ways:

- Direct broadcast satellites reaching individual user antennas;
- Satellites providing long-distance links to community or cable TV headend antennas, from which the programmes or other forms of information are carried to the subscriber via cable.

Between these two approaches there are the following trade-offs:

	<u>Direct Broadcast</u>	<u>Satellite to CATV Headend</u>
Earth Station		Less investment in a smaller number of ground stations
Satellite Transmit Power		Less
Cable Network	Not required	
Susceptibility to Interference from other TV satellites		Less

A TV broadcast system built exclusively upon satellites (direct broadcast) also has the following difficulties to cope with:

- Complete breakdown of system if satellite fails ("single point failure")
- Eclipse problem (communication blackouts)
- Shortage of orbital space for geostationary satellites

The investments involved in establishing a direct broadcast satellite system are considerable (even without the ground stations), and to our knowledge there is no reliable, objective analysis of the merits of direct satellite broadcast as against other means of TV programme delivery. Recently there has been considerable publicity given to proposals for TV broadcast satellites in several major European countries, including France and West Germany. While these satellites and the associated ground station equipment would provide interesting markets for manufacturers, it is less clear that these systems would work to the benefit of the consumer in terms of new or better services for the outlays the consumer would make, both directly for an antenna and indirectly in terms of the expenditure of public monies to establish these systems.

## 5. ROLE OF CATV NETWORKS

In principle, access to Videotex-type services can be provided via two-way CATV networks as well as the public switched telephone network. In EEC countries, a regulatory framework which would permit access to Videotex type services over local CATV networks has not yet been established. There is uncertainty and conflict, for example in West Germany and the U.K., as to the roles of the PTT and privately-owned organizations in the installation of CATV networks. Furthermore, the place of CATV even as a means of delivering basic TV programming, as an alternative to terrestrial - or satellite-based broadcast systems, has not been settled. CATV networks have thus far grown up as a result of one or more factors:

- Improved reception in areas poorly served by over-the-air broadcasting;
- Demand for foreign TV programmes in multilingual areas (e.g. Belgium), for which standards conversion is often necessary;
- (Primarily in the U.K.), economic attractiveness of a simplified TV set used in conjunction with a cable network.

In addition, internal cable TV systems within, for example, hotels have been able to carry programming other than off-the-air TV (e.g. feature films).

It should be noted that many of the existing cable TV systems in Western Europe are not suited to carry the large number of programmes (up to 30 TV channels) that modern CATV systems in North America can, nor are they readily adaptable to two-way operation.

As the price/performance characteristics of TV sets, and the coverage of over-the-air broadcasting have improved, so it

has become apparent that the future of CATV is at best stagnant, and more likely declining, unless new services are permitted, ranging from pay-TV (which does not necessarily require a two-way system) up to fully interactive database and message services.

a) Fibre Optics

There is much current interest in the applications of fibre optics as an alternative transmission medium to metallic cable, for telephone, CATV, data link, and various other communications and telecommunications applications. It is expected that as the cost of fibre cable comes down, the economic advantages of fibre optic systems will become decisive in a growing variety of applications. In the context of CATV, whether one-way or interactive, we feel it necessary to point out that, while important, fibre cable costs are not the only, or necessarily the dominant cost factor in determining the economic cost competitiveness of fibre optic systems.

Depending upon system requirements and architecture, major and often determining elements in total system cost can be multiplexer/demultiplexer equipment, and/or switching equipment. There is furthermore a significant gap in current component availability for fibre optics systems, namely an effective, economic optical tap. The techno-economic evaluation of the potential role of fibre optics technology in CATV and related systems requires thorough systems analyses, including alternative approaches in terms of signal modulation schemes (various digital and analogue types) and switched and non-switched architectures, as well as combinations of optical and conventional transmission technologies. New components, including for example optical taps already mentioned, integrated optical structures, wave division multiplexing techniques, and long wavelength sources and detectors (1.3 microns instead of the 0.85 microns in current systems) will serve to make



new system architectures feasible, and improved performance levels attainable.

We believe that fibre optic and related technology is of very great importance to telecommunications and some other types of application, and its development and commercialisation should therefore be encouraged within the EEC on grounds of general industrial competitiveness. We do not, however see this technology as being fundamentally important for the development of Videotex and related services, in the sense that there exist services which can only be implemented technically and economically within fibre optics systems. Fibre optics has become, and will increasingly become a technology which needs to be included in an evaluation of the best way to implement communications and telecommunications systems. We expect that in the 1980's fibre optics will be employed primarily in systems with signal processing being done electronically, rather than optically, and that in several areas, of which CATV is one, mixtures of technologies (e.g. fibre optics and metallic cable) may often provide the best solution.

## 6. CONSUMER ELECTRONICS INDUSTRY

In the EEC and other European countries, as in the U.S., Far Eastern and notably Japanese companies have made powerful inroads into consumer markets, and dominate some segments, such as audio equipment. Not only Japan, but in particular also South Korea, pose strong competitive challenges for the 1980's. The Commission thus has a legitimate and appropriate interest in examining how the competitive positions of European consumer electronics manufacturers may be improved.

A factor of great significance for TV-based or TV related markets in Western Europe in the 1980's is that the key colour TV patents are going to expire in 1980 or shortly thereafter (all of Western Europe except France has adopted

the West German PAL colour TV system). Now the licenses under which, for example, Japanese manufacturers can make and sell PAL TV sets in Europe include some restrictive clauses, including maximum limits on the screen size of sets that can be exported to European countries, if they come from a factory in a non-PAL country, such as Japan, and a requirement that any factory in a PAL country\* can export only up to 50% of its production. The latter restriction serves to limit the production of PAL sets in small countries, which have to absorb at least 50% of this production domestically.

Clearly with the expiry of PAL patents and the associated licenses, the European markets for PAL TV sets and related equipment will be open to much less restricted commercial competition than has been the case until now.

In this context and perspective, an interesting question is whether the extensive and rapid development of "intelligent" TV sets and ancillary equipment may provide increased competitive opportunities for European manufacturers in a rejuvenated TV market in facing up to Far Eastern suppliers. The answer is far from obvious, since there are no technical barriers to entry in these new markets by Japanese companies. It may be argued, however, that European manufacturers would stand a better chance in competing with software-dependent products whose success is less exclusively linked to production techniques than is the case with traditional TV sets. On the other hand, it is in the field of programmable products such as home computers that U.S. companies have great strengths. Thus, however TV-related markets develop, the success of European manufacturers is bound in large part to depend upon their own commercial and product development acumen and initiative, in addition to any actions that the Commission or other bodies in Western Europe may take to improve the potential competitiveness of European industry.

\*such as Hong Kong, Singapore and Ireland

The pattern in the traditional TV markets in the EEC seems to be moving in the direction, as already noted, of increased competition from the Far East, unless effective protectionist measures are taken. Partly in order to forestall these measures, Japanese companies are becoming increasingly closely involved with Europeans, through their own TV manufacturing plants (especially in the U.K.), on their own or in a joint venture, and through the granting of distribution or manufacturing licenses to European companies (as in the video cassette recorder business). We present as a hypothesis that the rejuvenation and redefinition of TV-related markets through intelligent products (as Videotex derivatives are increasingly likely to be) offers, at least potentially, new opportunities for European consumer electronics manufacturers to improve their competitive positions in European markets. European companies which succeed in this endeavour will almost certainly operate Europe-wide, rather than be confined largely to one national market, and will be able to benefit from comparable economies of scale as their U.S. and Japanese counterparts at the level of hardware modules.

The actions the Commission might undertake, or stimulate, to help European companies improve their competitive positions include the facilitating of Europe-wide communications equipment approval and interconnect procedures, and the stimulation of the early development in Europe of new product ideas, for example by arranging for venture capital funding to be available for new business ventures.

## 7. ORGANIZATION OF BROADCASTING AND TELECOMMUNICATIONS

The development of Videotex and Videotex-related services, both nationally in some countries, and internationally within the EEC, is complicated by the varied and in part competitive

structures of broadcasting and telecommunications organisations in Western Europe. In Western Germany the Federal jurisdiction of the Deutsche Bundespost contrasts with the State (Land)-based organisation of broadcasting. In Italy telecommunications responsibility involves SIP (primarily for local service), ASST for long-distance lines and Italcable for intercontinental traffic. Furthermore in Italy the broadcasting monopoly of the state-owned RAI has been challenged, and there exist a variety of other over-the-air programmes broadcast both from within Italy and abroad (Yugoslavia, for example). In Denmark local telephone services in many areas (Copenhagen and Jutland for example) are provided by privately-owned telephone companies, while the government-owned regulatory authority, the Department of Posts and Telegraphs, handles long-distance lines and local telephone service in some other regions. In contrast, broadcasting and telecommunications in France both fall under central government bodies, the TDF and PTT respectively, which have collaborated closely in the development of Antiope at a joint research centre. The statutes (and penetration) of cable TV also vary substantially from one country to another. In some cases private organisations have recently been challenging the extent of the authority of PTT's over cable TV systems, e.g. West Germany and Holland, and in the latter case successfully.

The consequences of the diversity, and still undefined regulatory structures affecting Videotex, in telecommunications and broadcasting in the EEC can have two adverse consequences. Firstly, within some individual nations the introduction of Videotex and related services may be delayed for years while regulatory questions are argued about. Secondly, within the EEC the spread of international Videotex services may be seriously hampered both by the gaps in national Videotex development, and by the difficulties in bringing into accord what may be different national rules and regulations governing Videotex. A corollary of a slow development of EEC-wide Videotex services could well be an encouragement of relationships between individual EEC members and non-EEC countries, notably the U.S.A. to offer

services, particularly to the business community, which are competitive with Videotex (e.g. the various international services providing access to U.S. data bases which are now being introduced).

The above analysis, which has pointed out some major regulatory and jurisdictional questions which hamper the commercial introduction of Videotex and related services, suggests that there is both room and a need for new international initiatives to permit a rapid EEC-wide growth in access to Videotex services, extending the first national initiatives which are put into operational practice.

#### 8. IMPACT UPON PUBLISHING

Concern has been expressed upon the potential impact upon news publishers of new communication services such as teletex and Videotex. For example, local display and classified advertising might migrate from newspapers to Videotex databases so as to erode significantly the former's advertising revenues. It does not seem likely to us, at least for the greater part of the 1980's that newspapers in the EEC will be significantly adversely affected by new communication services in this manner. The price of a newspaper to the consumer, and the convenient hard copy form in which it comes, are likely to remain highly competitive as against the cost of using communications-based services. In the longer run however (1990's and beyond), it is reasonable to anticipate, if Videotex-type services are available in a substantial number of households, that a major negative impact upon newspaper advertising revenues could arise. Teletext (one-way) services are likely to have less of an effect upon newspaper revenues, being confined probably entirely to headline news and immediately operational information such as weather reports, stock quotations, road conditions, etc..

We should emphasize at this stage that the above remarks do not represent the fruits of a careful and detailed examination of the prospects for the Western European news publishing industry, but rather initial qualitative judgements which require verification.

On the positive side, newspaper publishers can clearly hope for additional revenues by their participation in Videotex services as information providers. Data base services may be provided locally by them, as well as, for example, by used car and apartment and house listing services, retail advertising services, chain stores, and computer service operators. In addition to textual information retrieval, these services may provide electronic display of colour photographs, optional printing capability, shop-at-home features, and access to residential message services.

Newspapers' strengths lie in their packaging of a wide diversity of information and entertainment in a low cost form for consumers. Much unused material is however delivered to the consumer. Newspapers face significant competition for advertising from more specialized media (e.g. single subject publications, specialty information centres) which, however, typically lack the wide penetration of newspapers. Newspapers offer a heretofore unique combination of diversity, convenience, and economy. In principle, electronic media have the long-term potential to offer a new threat to newspapers by providing competitive, if different, mixtures of these same three features.

The potential threat of electronic media to newspapers is inhibited by a number of significant barriers. First among these barriers is the development of cost and pricing structures simultaneously economically attractive to consumers, the marketers of products and services, and the operators of communications media. Secondly there is a need for sufficient investment to provide desirable services during the growth

period of electronic systems, when unit prices are high enough to limit installation rates, and the installed base is relatively low, thus limiting revenues. The rapid expansion of electronic systems in the home may be helped by cross-subsidization of operations (e.g. business systems subsidizing home systems), and by government action (as by direct subsidy or public service activities). The government's role can, on the other hand, limit progress in electronic media by regulation, or confuse the situation by inaction.

#### 9. USE OF DATA BASES

Videotex is inevitably involved in the legal, regulatory, social and political issues which the spread of data communications and the use of information stored in computer-controlled data bases are generating or rather presenting in a new and more urgent guise. These issues include in particular rights of privacy, access, security and confidentiality, the free flow of information within and across national borders, questions of copyright and so forth. The nature of these issues becomes especially complicated at the international level (transnational data flow, within the EEC and between the EEC and the rest of the world), as a consequence of the very different legal, social, regulatory and political traditions of the countries concerned. In particular from the U.S.A. arguments have been forthcoming in favour of relatively unrestricted transnational data flow, to permit so-called market forces to determine the optimum pattern of use of data communications facilities and data base services. Europeans are concerned that the industrial and commercial strength of the U.S.A., and the lead this country enjoys in data base services, should not lead to a dominance of U.S.-based information services. Not only might such a dominance submerge distinctive European points of view in social and cultural terms, but also it might dangerously weaken Europeans' ability to control themselves the proper use of

information. There can be no guarantee, for example, that information use considered improper by Europeans would also be so regarded by Americans. Some information, for example economic data (on companies, economic resources and so forth) may be considered so valuable that it must be stored within the physical control of a European nation or Community organization (the argument of sovereignty). Storage of certain classes of information (especially personal data) in foreign data bases may be prohibited unless the data protection legislation of that country meets some minimum specification.

The development of Videotex services, especially in their international aspects, is subject to all the complex regulatory questions which concern the use of telecommunications and data storage and processing facilities. If the regulatory questions are not to inhibit the development of Videotex, it is important that there develop, if not a harmonised Community approach which appears to be practically unattainable in the near future, at least a minimum framework of standards which national solutions take into account in their formulation. In analogy to the situation prevailing with regard to nuclear safeguards, a basic Community-wide set of rules regarding rights of access to data could be established to which all national legislation should, as a minimum conform. By this kind of approach, which would not necessarily exclude individual national initiatives in accordance with local national priorities, the development of Community-wide Videotex or related services might not be actively stimulated, but at least it would not be positively inhibited.

#### Impact Upon Business Information Services

There exist many business information services operating prior to Videotex, and the question arises whether comparatively inexpensive Videotex-based services may undercut these. Alternatively the question is how companies (including for example consulting organizations such as the one responsible for this report)



should price their Videotex information compared with their traditional services. We expect that organizations such as travel agents, house agents, business consultancies and other professional services will eventually feel the impact of Videotex and related services upon the ways and economics of their doing business.

#### 10. VIDEOTEX AND THE RESIDENTIAL USER

In the development of Videotex and related services, the users, or more broadly, the citizens of the countries in which these services are available, are both active participants drawing upon and influencing the services, and subjects upon whom the services have an effect. Videotex data bases can contain information and ideas users may usefully exploit, as well as information on users which businesses or governments may find valuable in their operations involving their customers or their country's citizens. In this perspective then, Videotex services are involved in the very broad concerns related to the use and misuse of information, notably privacy and consumer protection. There is a growing and deep-seated, interest, for example, in questions related to the transnational transfer of data. The development of Videotex services using the telephone network, which is the most widespread international means of telecommunications, heightens the importance of establishing rules for the international use of information services.

The advantages which Videotex or related services can offer the average consumer are several. There is much information, useful in everyday life, that is not easily or rapidly accessible, and often requires a tiresome journey in order to be found.

It can also be argued that ready access to more extensive information on products and services available may permit consumers to make better purchasing decisions. In regard to these last remarks, Videotex services overlap significantly with other telecommunications - and nontelecommunications-based services e.g. department store catalogues, classified newspaper advertising, and telephone calls to information services.

Ready access to a broad range of information at home may also facilitate working at home rather than in the office\*, and in the limit further the growth of new "cottage" industries (similar for example to software program development being carried out by housewives with spare time at home). We enter here a realm ripe for speculation, in which firm prediction is very risky. The important point to bear in mind is probably not a need for more exact prediction, but rather a need to ensure a sufficiently flexible and innovative environment that new styles of working and operation can be tried, even if many of them turn out to have little long term interest.

\*Although the value of working away from home should not be underestimated e.g. the serendipitous exchanges of ideas among colleagues, and the desire not to spend all one's time in the same environment.

## ISSUES FOR FURTHER ACTION

### 1. INTRODUCTION

Videotex and related services are but one element of a broader panorama of subjects which fall under the general heading of Information. They lie in the fluid, but increasingly important region of overlap and interaction between telecommunications and information processing. They are furthermore intimately linked to the spread of powerful data processing capabilities to within the reach of smaller, and often unsophisticated user organizations, including individual consumers themselves, which is the result of the remarkable and continuing progress in microelectronics technology.

The recent developments in Videotex systems and services in Western Europe owe much not only to the underlying, and universal, technological trends, but also to the local conditions and regulatory and organizational structures already in place in the members of the EEC, particularly the roles and traditions of PTT's and broadcasting organizations. There is nothing inevitable in the particular service concepts grouped under the term Videotex, and as we have seen in previous chapters, many aspects of these services are in part complementary, and in part competitive to other information services developed or being developed elsewhere, notably in North America and Japan. Videotex services are being developed and offered in Western Europe in societies which, to varying degrees, are in many respects today less "information rich" than the U.S.A.

In light of the major roles which PTT's play in EEC members, as providers of telecommunications infrastructures, as major investors, and in some cases major research and development centres, it is to be expected that they should have a key role to play in the development of Videotex and other telecommunications-based services. It is also the case however that the implications of these new services extend well beyond the spheres of authority and interest of telecommunications common carriers per se, and that, as already discussed, the full potential benefits of advanced communication

services (for the consumer, the equipment supplier, and other commercial and industrial sectors) can only be realized if there is a much more pluralistic approach to them than has been the case with, for example, older telecommunications services such as telex. Several PTT's have of course already publicly expressed their awareness of this situation, and shown a willingness to be open to new approaches.

In the remainder of this chapter we summarize the issues which Videotex, and other advanced communication services raise or sharpen, from the viewpoint of how the potential benefits of these new services are most likely to be realizable and realized.

## 2. STANDARDS

We are not convinced of the value of developing a common, international standard for Videotex, which indeed would have several undesirable aspects. However, there is a need for international Videotex (or similar) services, and the issue then arises of how best to implement these. Elements necessary to provide an international service might include aspects of data base design, to provide for several versions of presentation on different terminals; translators to handle normally incompatible protocols; and "universal" terminals based for example upon a high resolution pattern generator as opposed to a hardware character generator.

The questions to be resolved are then those of the framework for the choice, development, and implementation of hardware and software designed to ensure the availability of more powerful Videotex services, and that on an international level, starting from the basis of more limited national systems.

### 3. TERMINAL EQUIPMENT INTERCONNECTION

In the previous chapter we described the potential advantages, as well as some of the social and industrial inhibitions against liberalizing terminal equipment approval and interconnection procedures. The key issues which have to be dealt with in overcoming these inhibitions are how to introduce, ideally throughout the EEC, more liberal interconnection rules without disfavour to any one country in competitive terms against fellow EEC-members, and the rest of the world; and how to handle questions of equipment fault diagnosis, maintenance, and repair so that problems can be located quickly (e.g. terminal, modem, or network). Notably in the U.K., the issue of liberalised interconnection of terminal equipment is also bound up with questions of employment and job structure, where a union is concerned with ensuring, or maintaining an effective monopoly on the maintenance of certain classes of telecommunications equipment for its members.

### 4. TRANSMISSION MEDIA

We have identified two different types of issue concerning transmission media for Videotex and related services. Firstly, cable TV networks can be used as a local transmission network for Videotex-type services, and are being so used in North America and Japan. Under current regulatory conditions, this usage of CATV networks is not generally possible in Western Europe. Further, in some major European countries the growth of CATV as a whole is strongly inhibited, irrespective of Videotex. While CATV and the telephone network are largely complementary, from the user's viewpoint, for Videotex services, the CATV medium does offer much higher transmission capacity, as for example suited to the display of photographs. We do not see Videotex or similar services as being a major factor in a desire to expand the role of CATV networks (pay-TV is probably a much more immediate short-term source of revenue), but Videotex does nevertheless give added weight to arguments pointing out the potential utility of the wideband cabling of European cities and towns.

The second issue concerning transmission media is not independent of the arguments revolving around CATV, being linked to the particular technology of satellite communications. Satellite transmission direct to the home is a one-way medium, and thus not suited to interactive Videotex, but only to one-way teletext services. However, as discussed in Chapter IV.1, satellites could play a role as an intermediate or long-haul Videotex databases.

Satellites are competitive with CATV networks in the sense that if direct broadcast satellites are used to distribute TV programming, one of the "raisons d'être" of CATV networks is removed. In the previous chapter we pointed out some of the severe disadvantages, as well as capabilities of direct broadcast satellites, despite which plans for these satellites are apparently going ahead in some Western European nations. We believe that the case for direct broadcast satellites is far from being proven in comparison to other alternatives (including hybrid satellite-CATV networks), and that this issue is relevant to Videotex in light of the roles which satellites and CATV networks can play as Videotex delivery systems.

## 5. NETWORK INTERCONNECTION

The original Videotex service concepts involve the use of the public switched telephone network. Connection to the telex network has been envisaged, for example, by the British Post Office to handle a message service. There are also, however, several other types of telecommunication network interconnection of Videotex which could fruitfully expand the ranges of services and customers of Videotex. These other networks include in particular business leased line networks, and public national and international data networks.

Policies of Western European PTT's are generally far more restrictive in terms of permitting leased line interconnection to the public switched telephone network than is the case in the U.S.A. Large businesses with leased line networks, and their own Videotex

systems, may well wish to be able to connect into public Videotex data bases using their existing leased lines to move the data around internally. The issues here, from PTT's points of view, are the classic ones of the effects on their revenues of permitting fixed price leased lines to be used in this way (usage-sensitive prices for leased lines have been suggested), both directly as a result of the revenues accruing from differently tariffed circuits, and somewhat less directly in terms of the attractiveness to businesses of making more or less use of PTT - as against privately-run Videotex data bases.

More generally, looking at Videotex in the broad context of data base services, there is the issue of the desirability of permitting access from one and the same terminal to Videotex data bases on the telephone network, and to data bases connected to other networks such as Transpac (France) and Euronet (EEC). The advantage, if the price were right, would be a broadening of the customer base for all the data base services involved. The operational questions connected with this issue involve the definition and development of network interconnection procedures, tariff structures, and sharing of revenues among the parties involved.

#### 6. VIDEOTEX AND OTHER BUSINESS INFORMATION SERVICES

Videotex services are not coming into being in the absence of other telecommunications - and computer-based information services for businesses, some of them purely internal to a business, whereas others are offered commercially. As a commercial service, Videotex may compete directly with, or in some cases complement other forms of information service; further some businesses may prefer to instal internal Videotex systems, possibly with interconnection to public systems, rather than make great use of external Videotex services.

As originally developed, Videotex services are designed to be at the low cost, limited capability end of information services. An issue for future developments is how far and how fast downward compatible, more powerful Videotex systems will be developed, comparable to some of the business services described earlier. An important element in the ability of Videotex to cover a larger proportion of business information needs will also be its inter-connection to data networks, as discussed in the previous section.

There is an issue not only of where Videotex may fit into the overall scheme of business information services (offering low cost services to businesses some of which may not be able to afford alternatives, and expanding upwards over time in capabilities), but also of how a Videotex-based infrastructure in Western Europe (in terms of networking and terminal equipment) may raise the prospects for European-based information service providers to compete with their overseas, primarily U.S., counterparts. A competition appears to be developing between transatlantic access to U.S. data bases, and the development of effective Europe-wide data base and communications infrastructures to limit European dependence upon U.S. services.



## RECOMMENDATIONS

### 1. STANDARDS AND INTEROPERABILITY

The Commission should act as a clearing house for information on Videotex and related developments, establish standards of documentation for Videotex standards, and act as a Videotex documentation centre. We do not believe there will, nor should there be a single, Community-wide Videotex standard in use, but the Commission should do its utmost to foster the interoperability of, and international access to differing Videotex systems. For example, the Commission should promote the development of translators, as described elsewhere, to ensure that Videotex services can be provided on an international basis.

The Commission should strive to play the role of an international clearing house for information on Videotex developments, to which equipment manufacturers, data base operators and information providers, and national Videotex system developers could address themselves. It cannot be too strongly emphasized that, provided attention is paid in the early stages of data base design to the requirement for catering for presentation in several different formats, a relatively marginal effort is involved in extensions to providing interfaces to new Videotex type standards. The Commission needs to ensure that there is a continuous mechanism for interaction and software (and to a more limited extent hardware) development related to international Videotex interoperability. This mechanism may be based upon the sources of expertise which the Commission has been exploiting in Euronet developments, particularly if the recommendations made by Telesystems regarding Euronet/Videotex interfaces and gateways for interconnection between national Videotex systems are implemented.

## 2. TERMINAL INTERCONNECTION

In light of the different national procedures for approving and handling telecommunications terminal interconnection, the Commission should develop recommendations with the objectives of (a) liberalising approval and interconnection procedures throughout the EEC, subject to avoidance of disruption in trade patterns (as discussed elsewhere), and (b) permitting equipment to be approved once for all EEC countries. We agree with the suggestion put forward by PA Management Consultants concerning the creation of a network of national test centres, or possibly a single Community standards laboratory to certify, in one procedure, Videotex interconnect products for use in all Community member countries.

## 3. SATELLITE

Large investments have been proposed in European satellite systems for TV broadcast, whose implementation could have a significant effect upon the consumer TV market and the structure of transmission networks available for Videotex and related services. An objective evaluation of the merits of satellites and alternative delivery systems for TV programming in Europe has not, to our knowledge been made. In light of the international implications, the Commission could appropriately initiate an investigation into the economic and operational merits and disadvantages of alternative TV transmission systems for conventional programmes and advanced communication services.

- . Estimated Cost: 5 - 8 man years
- . Calendar Time: 12 months

#### 4. CABLE TV NETWORKS

It does not appear at all likely that cable TV networks will be permitted to play a significant role in the development of Videotex-type services in most, if not all of the EEC countries during the first half of the 1980's at least. Cable TV is in a region of overlap between PTT's and broadcasting. The regulatory obstacles to the development of new services on CATV, and the uncertainty of the roles CATV system operators other than PTT's will be allowed to play, are not apparently going to be resolved in the near term.

We believe nevertheless that cable TV networks can be a useful distribution medium of Videotex-type services, as a valuable alternative in some instances to the telephone network, and with some additional capabilities (wide bandwidth). In the absence of significant, short term national activities in the development of new cable TV services, and equipment needed to provide them, the Commission may wish to consider sponsoring alone, or jointly, a pilot interactive CATV project in an EEC country, analogous perhaps to the Japanese HIOVIS project. Such a project might test not only new services and terminal equipment, but also new fibre optics technology, even if this technology is not yet an economical way to implement the system. It is possible that the Commission may be able to interest in such a project organisations in one of the members of the EEC where there is already a significant penetration of modern CATV systems, e.g. the Netherlands or Belgium.

If we postulate an interactive CATV system involving some 300 terminals or subscribers, a rough estimate of the total capital costs involved would lie between 3-4 million EUA. This estimate includes the cost of some equipment not readily commercially available at the moment, and therefore relatively expensive. The first stage of a project of this nature would consist of an initial budgetary proposal and system design, which by itself would cost in the neighbourhood of 150,000 - 200,000 EUA.

5. COMMUNITY AS A USER

We recommend that the institutions of the European Communities, and in particular the Commission, install for their own use advanced communication systems, such as Videotex. Contracts from the Commission for the development and installation of these systems, and their use by the Commission, would encourage manufacturers, information providers, and other potential users to appreciate the value to them of these systems. In this sense the Commission, playing the role of a "leading edge" user, could develop experience extremely valuable for the user community.

The Videotex systems and services used by the Commission should include other Community institutions, for example the European Parliament. Access to Videotex systems by members of the European Parliament, who have very important needs for information, could be an effective way of heightening awareness of the importance of advanced communications in all Community member states.

6. COMMUNITY AS AN INFORMATION PROVIDER

We recommend that the Commission itself take an active role in providing services useful to Videotex subscribers, including an interconnection to Euronet, as described by ~~Télé-~~ systèmes, and access to the data base services available on Euronet.

7. COMMUNITY AS A SOURCE OF RESEARCH AND DEVELOPMENT FUNDING

Earlier recommendations concerning Videotex standards and interoperability, and cable TV networks, have already implicitly involved the Commission in research and development funding (of Videotex interfaces and pilot interactive CATV systems). These two areas were identified because in the first instance (international interoperability) there is a natural role for the Commission in promoting inter-

connection between different national networks, and in the second instance (CATV) there is, as far as we can tell, a gap in European projects which the Commission may wish to fill in the absence of any energetic initiatives by other parties. We believe that these two general conditions, or at least one of them, should be met in the use of research and development funds by the Commission, (1) that there be a natural international role within the EEC, and (2) that there be an absence or apparent insufficiency of initiatives by other concerned parties (national governments, manufacturers and so forth). Thus, for example, there are many important developments in electronic and data processing componentry going on of which the Commission needs to be aware, but for which no special further direct funding is needed (although actions encouraging the early development of markets for systems using these components may be valuable).

In addition to the developments in the fields of Videotex system (including data base) interoperability and cable TV described above, the most important fields for the Commission in stimulating developments through research and development funding lie in applications. Applications projects which the Commission, on its own or jointly, might sponsor lie in a number of different fields including, as PA Management Consultants have suggested public service fields (medecine, law, education, welfare, and employment) and technical fields such as automatic translation. In particular, given the very uneven level of multilingualism within Community countries, educational projects aimed at improving practical foreign language skills should be explored as a Videotex application.

Required funding for applications projects of this type is notoriously difficult to predict and manage. A feasibility and design study for a major project would be expected to cost between 100,000 - 300,000 EUA, and a major implementation stage would involve expenditures typically one order of magnitude greater.

## **LECTURE: Videotex Display and Information Access**

*Mr. I. McLaren, PA Design Unit, London*

In this study we have tended to focus more on the standpoint of the user than the aspect of the infrastructure... as we feel that this approach has been rather neglected by the current European PTTs.

Our published material compares Prestel in the '76 format with an idealized subject, then a comparison of Teletel and Prestel in the '78 standard, and a comparison between Telidon and Captains. Our test subjects were projected in the form of slides, in three languages, to groups in the UK, France, Germany and the Netherlands. The audience was comprised of representatives of business, government, domestic and education contexts. The results were statistically evaluated by my colleagues at Pactel.

We formulated, for our field work, the classification of graphics formats, in colour and in monochrome. The first set of comparisons places Prestel '76 standard results alongside an idealized subject. (See plate 1.) The first part of this field work was conducted in terms of purely alphanumeric displays, namely, text with a heading, a second example providing text with a sub-heading, and a third example of tabular text. The Prestel '76 example is shown on the left, and the idealized video example is on the right. First of all, the examples are shown in colour. As you probably know, the Prestel '76 standard permits only a black background, whereas some sort of coloured background has been thought desirable in our idealized subjects. One probably also needs to have the facility of displaying in both black and white on that background, and one may have expectations of a rather more elegant letter form, which is currently available.

The same examples were prepared in monochrome (see plate 2) and subjected to the same audiences.

Our second set of field tests was concerned with more graphic material. (See plate 3.) Here we are obviously limited to the current generation of videotex systems in Europe, which are very much a result of text communication technologies, and it's therefore a trifle naive to push them to the degree that we have attempted in this demonstration. The possibility of illustrating the tabular set of information shown in the previous example is augmented by bar chart techniques. Plate 4 provides a monochrome version.

One of the most telling tests is cartography. The most significant obstacle is not just that of the graphic rendering, but also the capability of including text with the graphics. In the case of the map, in the original, there is a certain amount of annotation which we have had to reduce considerably in the videotex example. The pictogramme example (plate 3) is no doubt a little too flattering with respect to the current generation of European videotex, in that it was designed with the limitations very much in mind. For example, one cannot draw arcs, whereas one can to an extent draw diagonals. This Prestel example actually used the flashing feature for some of the little star-type elements in the forestry pictogramme. Incidentally, because of the limitations in the current generation, many Prestel pictogrammes represent automobiles, for example, from a front view, because of the impossibility of drawing nice round wheels!

The videotex example of a photograph provides a surprisingly tolerable rendering of a building. This could of course be considerably improved by the sort of additional graphics features to be found in the Canadian Telidon system.

Plate 5 provides three examples of Antiope images that were produced at Rennes in France. The French examples are a bit more elegant, but the British examples are a very close equivalent.

Let us now compare Telidon and Captain. Plates 6 and 7 reproduce published examples from both systems. The Canadian project is based upon a very different technology to that employed in Europe. They use computer graphics, and are therefore not inhibited in the same way as European designers. The Canadian technology permits very elegant drawing programs for arcs and diagonals... which appear to be well matched in the Japanese examples. For the cartography examples, we have two very elegant maps. In the case of Canada, there is the capability of rendering a half-tone photograph. In fact, Telidon offers the possibility of eight tones of grey. The Telidon capability of producing a very credible map is surprising. One should bear in mind that these Telidon examples were produced totally "blind". We - i.e., PA Design Unit and Pactel - had very little communication with the Canadians... far less than with the French and British PTTs. These Telidon examples were produced exclusively by Canadian personnel, on the other side of the Atlantic.

Let me now present the findings of the statistical evaluation of our field work. Quality can be recognized both in terms of technological quality, and quality of the authorship. Concerning information access, for Prestel IPs, there appears to be a fairly strong anachronistic bias towards the use of print conventions when drawing up data base tree structures and routing structures generally. Our conclusions from our

field work suggest that colour is a feature just as important as quality... which is perhaps surprising. And colour would seem to be equally important in both the domestic and business environments. As for editing, keyboards appear to be very inefficient, even when producing pure text, as in the current generation of text communication systems. We conclude that both Prestel and Teletel are "first generation systems", designed essentially for text transmission, with very limited graphics capabilities. We suggest that "second generation systems" will require true graphics capabilities. For example, more than forty characters a line would be a considerable advantage whenever text has to be combined with graphics. And the design of the character generator could be considerably improved if a variable character width were available. (I understand that this possibility already exists in the current generation of Telidon equipment.) We feel that the Commission has a rôle to play in establishing a product release strategy.



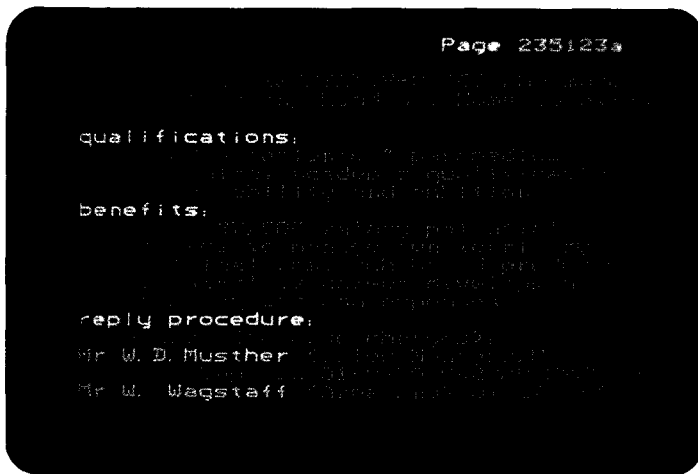

1.1 Text plus secondary heading/Prestel

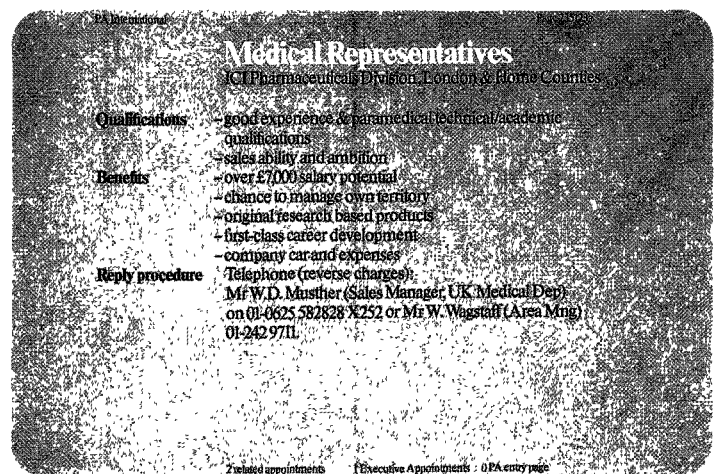

1.2 Text plus secondary heading/Video



1.3 Text plus principal heading/Prestel

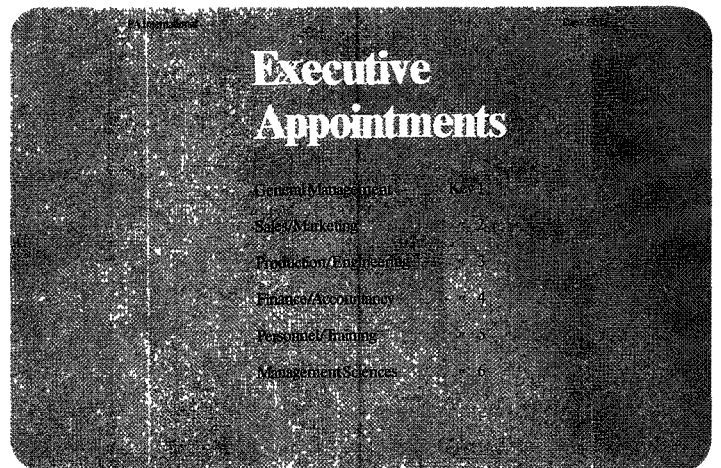

1.4 Text plus principal heading/Video

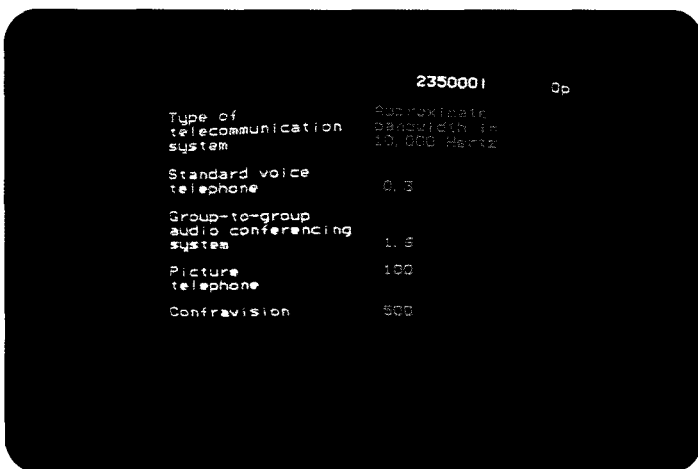

1.5 Tabular text heading/Prestel

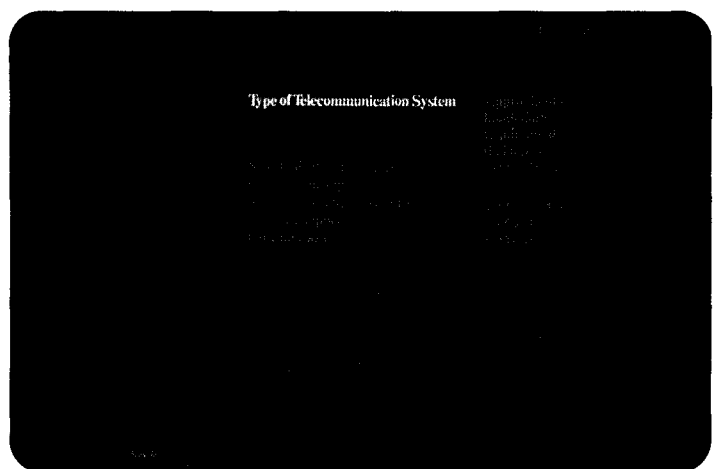

1.6 Tabular text heading/Video



PA INTERNATIONAL Page 235123a  
 MEDICAL REPRESENTATIVES ICI Pharmaceut-  
 icals Division, London & Home Counties

**Qualifications:**  
 - good experience & paramedical  
 technical/academic qualifications  
 - sales ability and ambition

**benefits:**  
 - over £7,000 salary potential  
 - chance to manage own territory  
 - original research based products  
 - first-class career development  
 - company car and expenses

**reply procedure:**  
 Telephone (reverse charges):  
 Mr W. D. Musther (Sales Manager, UK  
 Medical Dep) on 01-0625-582828 X252 or  
 Mr W. Wagstaff (Area Mng) 01-242-9711

2 related appointments  
 1. Executive Appointment  
 0. PA entry page

1 Text plus secondary heading/Prestel

**Medical Representatives**  
 ICI Pharmaceut- icals Division, London & Home Counties

**Qualifications:** Good experience in the medical technical or chem-  
 ical field and minimum  
 over 4,000 sales potential

**Benefits:** Chance to manage own territory  
 - original research based products  
 - first class career development  
 - company car and expenses

**Reply procedure:** Telephone (reverse charges)  
 Mr W. D. Musther (Sales Manager, UK Medical Dep)  
 on 01-0625-582828 X252 or Mr W. Wagstaff (Area Mng)  
 on 01-242-9711

2 Text plus secondary heading/Video

PA INTERNATIONAL Page 2351a

**EXECUTIVE  
 APPOINTMENTS**

1 General Management  
 2 Sales/Marketing  
 3 Production/Engineering  
 4 Finance/Accountancy  
 5 Personnel/Training  
 6 Management Sciences

3 Text plus principal heading/Prestel

**Executive  
 Appointments**

General Management  
 Sales/Marketing  
 Production/Engineering  
 Finance/Accountancy  
 Personnel/Training  
 Management Sciences

4 Text plus principal heading/Video

PA INTERNATIONAL 2350001 Op

Type of telecommunication system	Approximate bandwidth in 10,000 Hertz
Standard voice telephone	0.3
Group-to-group audio conferencing system	1.6
Picture telephone	100
Confavision	500

Key 2

5 Tabular text heading/Prestel

Psychometrica Page 25400

Type of Telecommunication System	Approximate bandwidth requirement (in Hertz)
Standard voice telephone	3000-4000
Group-to-group audio conferencing system	10000-16000
Picture telephone	10000000
Confavision	50000000

Key 0

6 Tabular text heading/Video

Publisher's note:  
 The monochrome reproduction from colour originals has resulted in a loss of image quality.

—

1

Plate 3 Comparison of Prestel and Video, graphic displays, colour

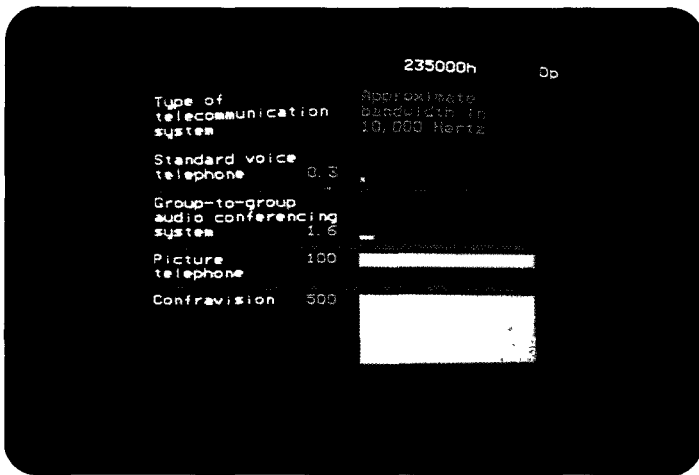

3.1 Bar chart, Prestel

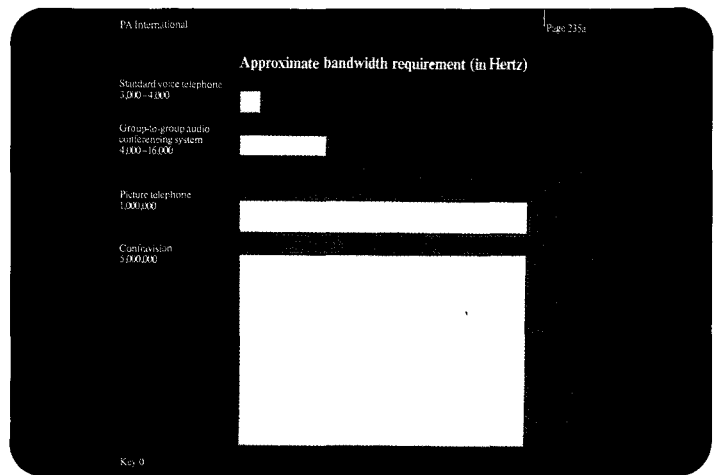

3.2 Bar chart, Video

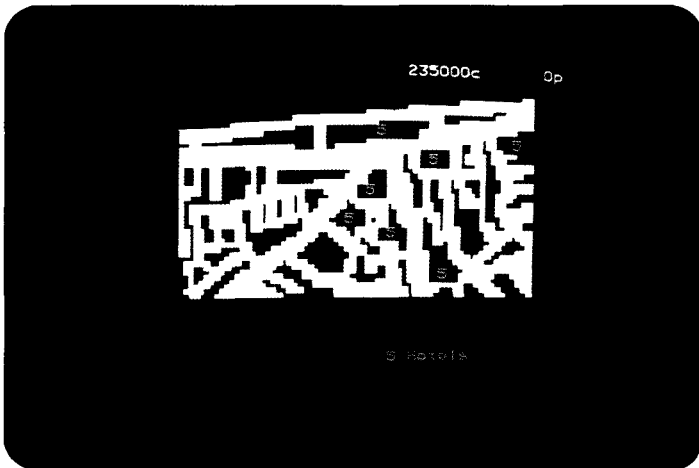

3.3 Cartography, Prestel

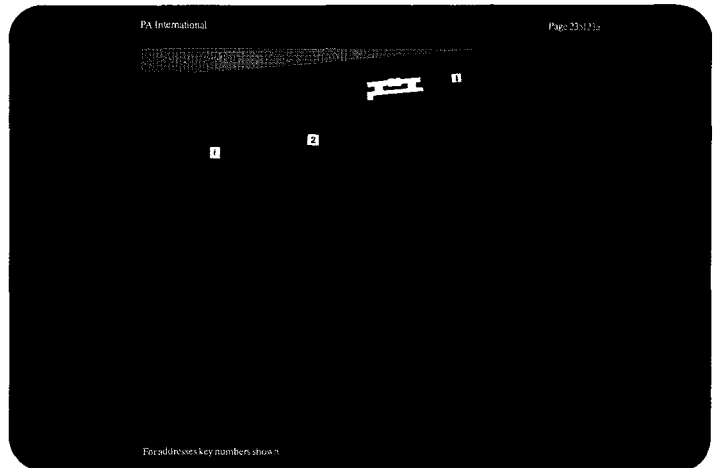

3.4 Cartography, Video

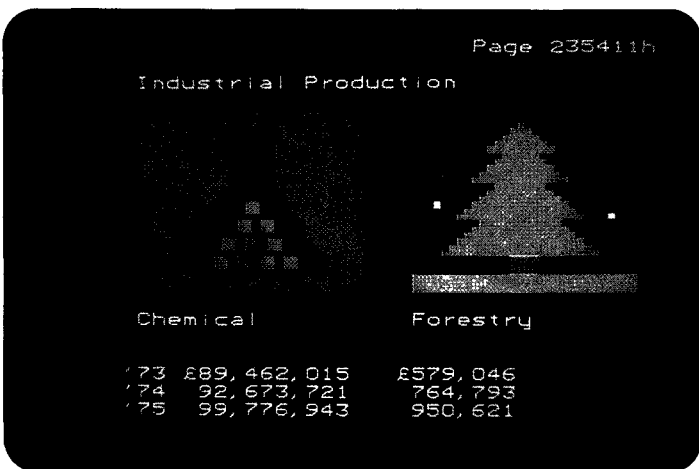

3.5 Pictogrammes, Prestel

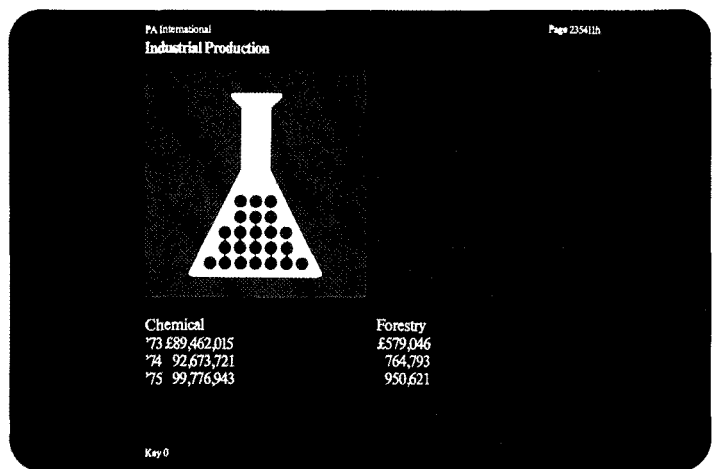

3.6 Pictogrammes, Video



3.7 Photograph, Prestel

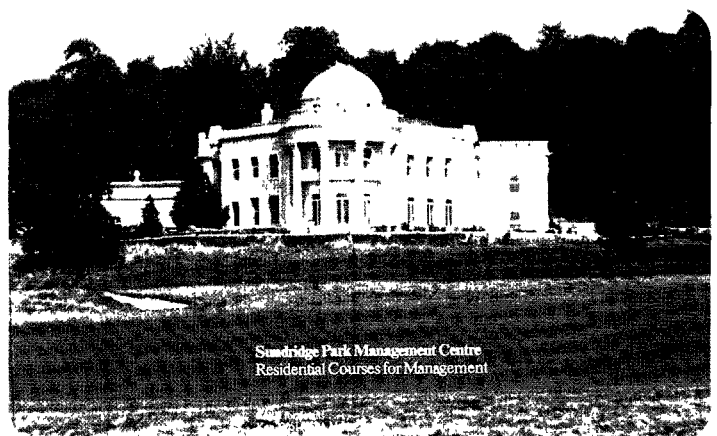

3.8 Photograph, Video



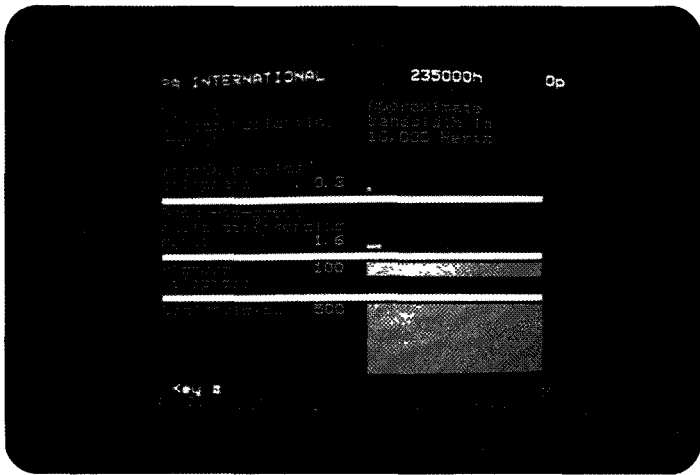

1 Bar chart, Prestel

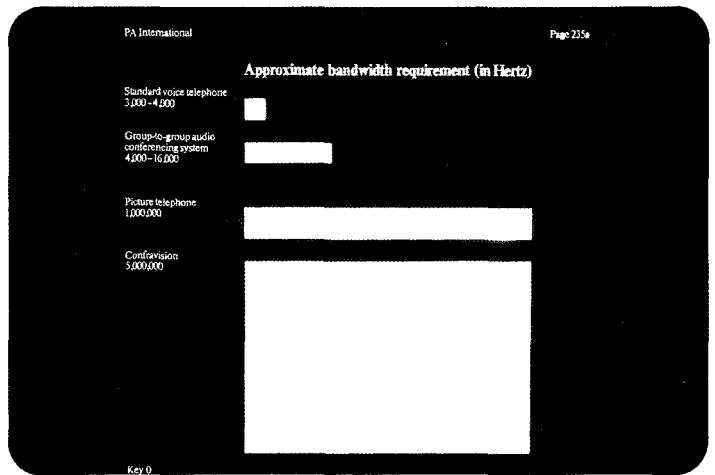

2 Bar chart, Video

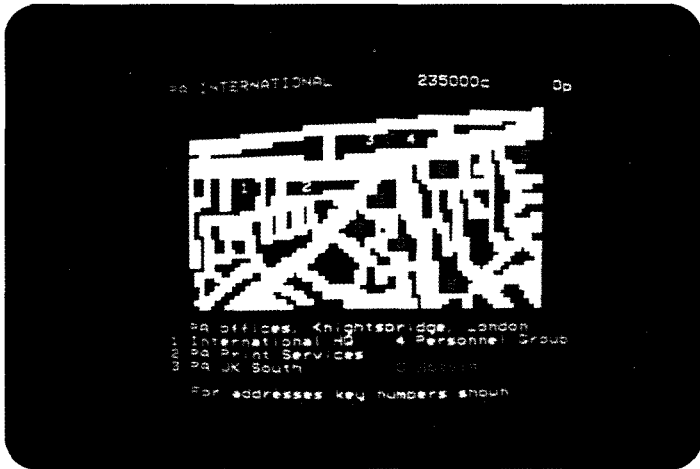

3 Cartography, Prestel

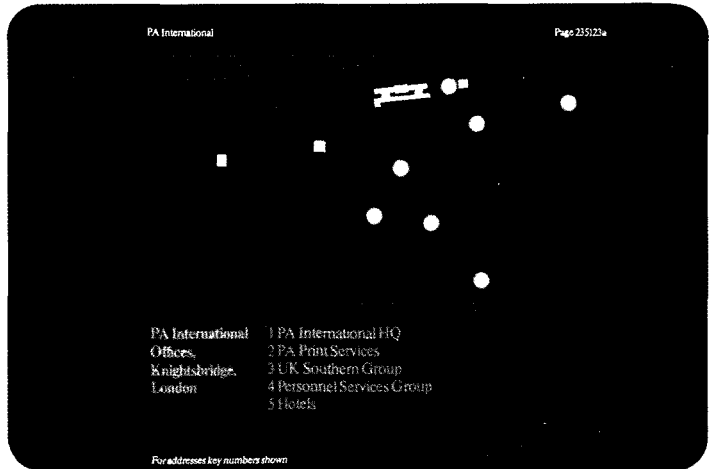

4 Cartography, Video

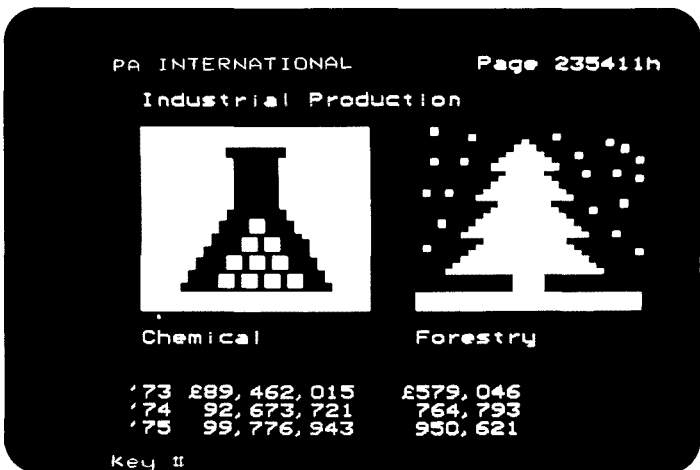

5 Pictogrammes, Prestel

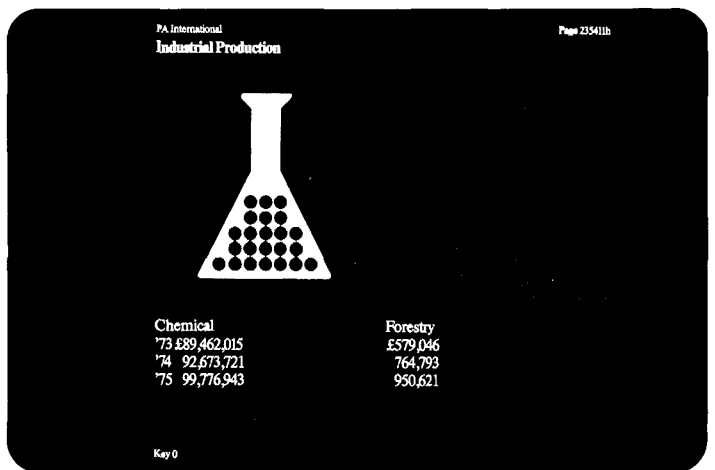

6 Pictogrammes, Video



7 Photograph, Prestel



8 Photograph, Video





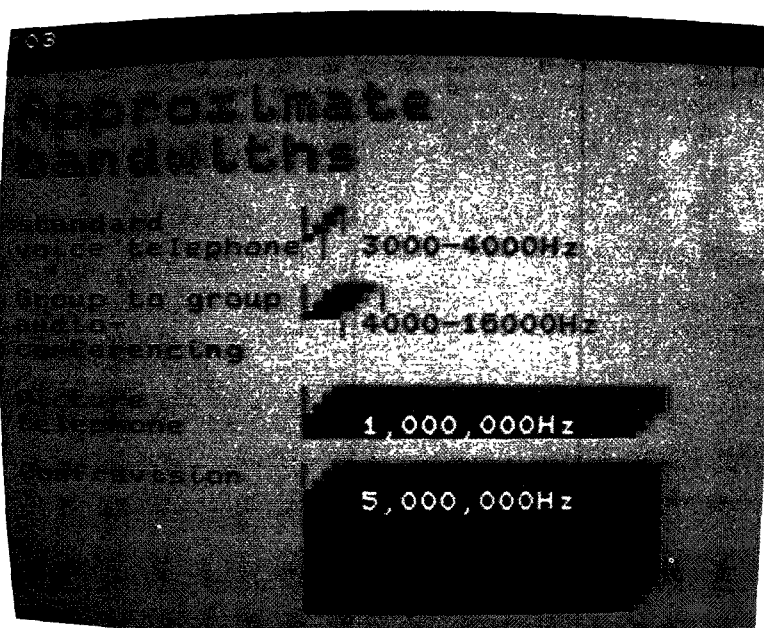

5.1 Bar chart



5.2 Cartography

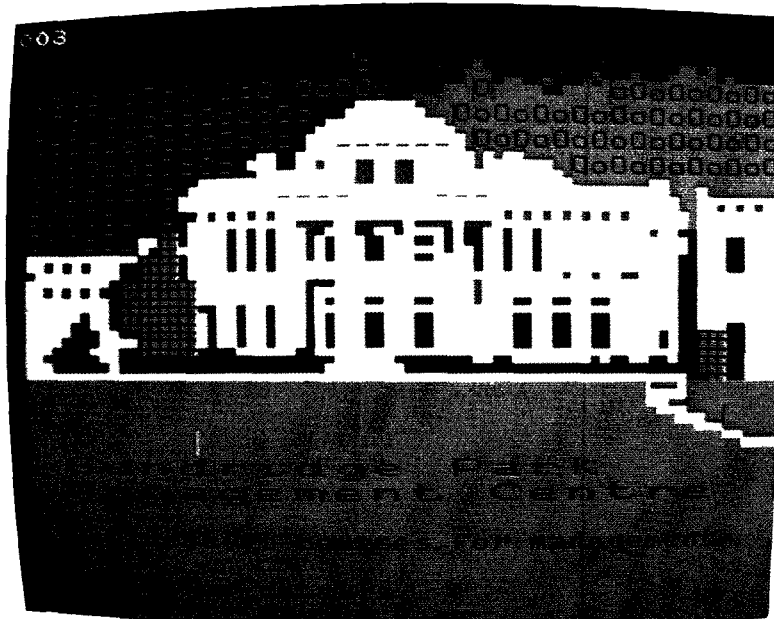

5.3 Photograph



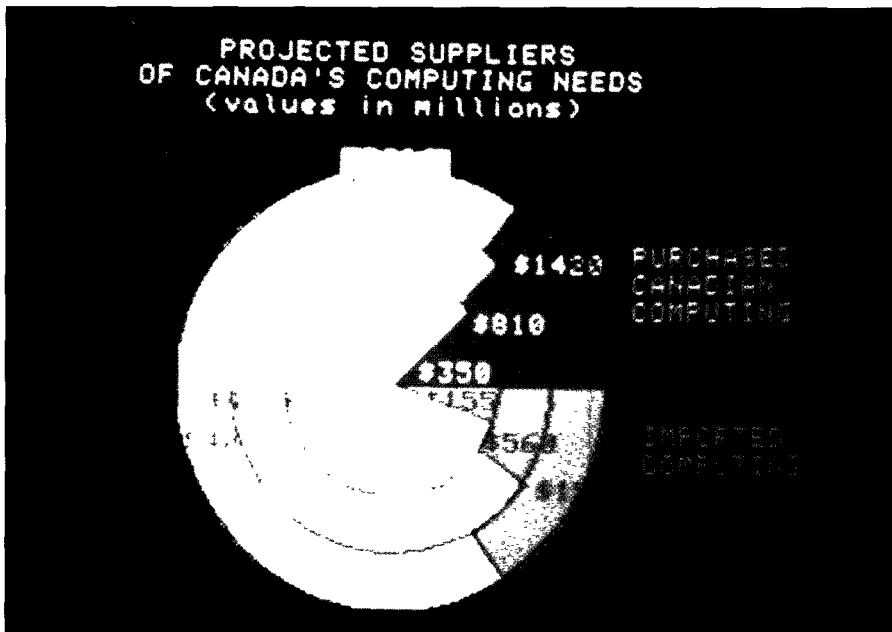

6.1 Pie chart

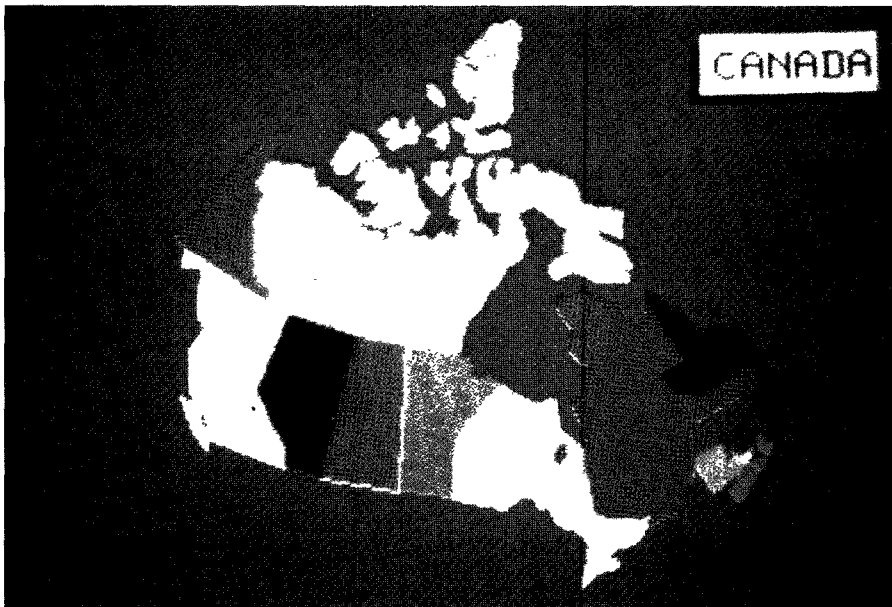

6.2 Cartography

PRIME MINISTERS OF CANADA

SIR JOHN A. MACDONALD  
1867-1873  
1878-1891



Macdonald was one of the principals in formation of the Canadian nation and was its first Prime Minister. He was its leader for 19 of its first 24 years.

He persuaded remote British Columbia to join in 1871 and Prince Edward Island in 1873. He formed the new province of Manitoba in 1870. He actively supported the building of the Canadian Pacific Railway. He died in office in 1891.

TELIDOM PAGE 84.1

6.3 Photograph

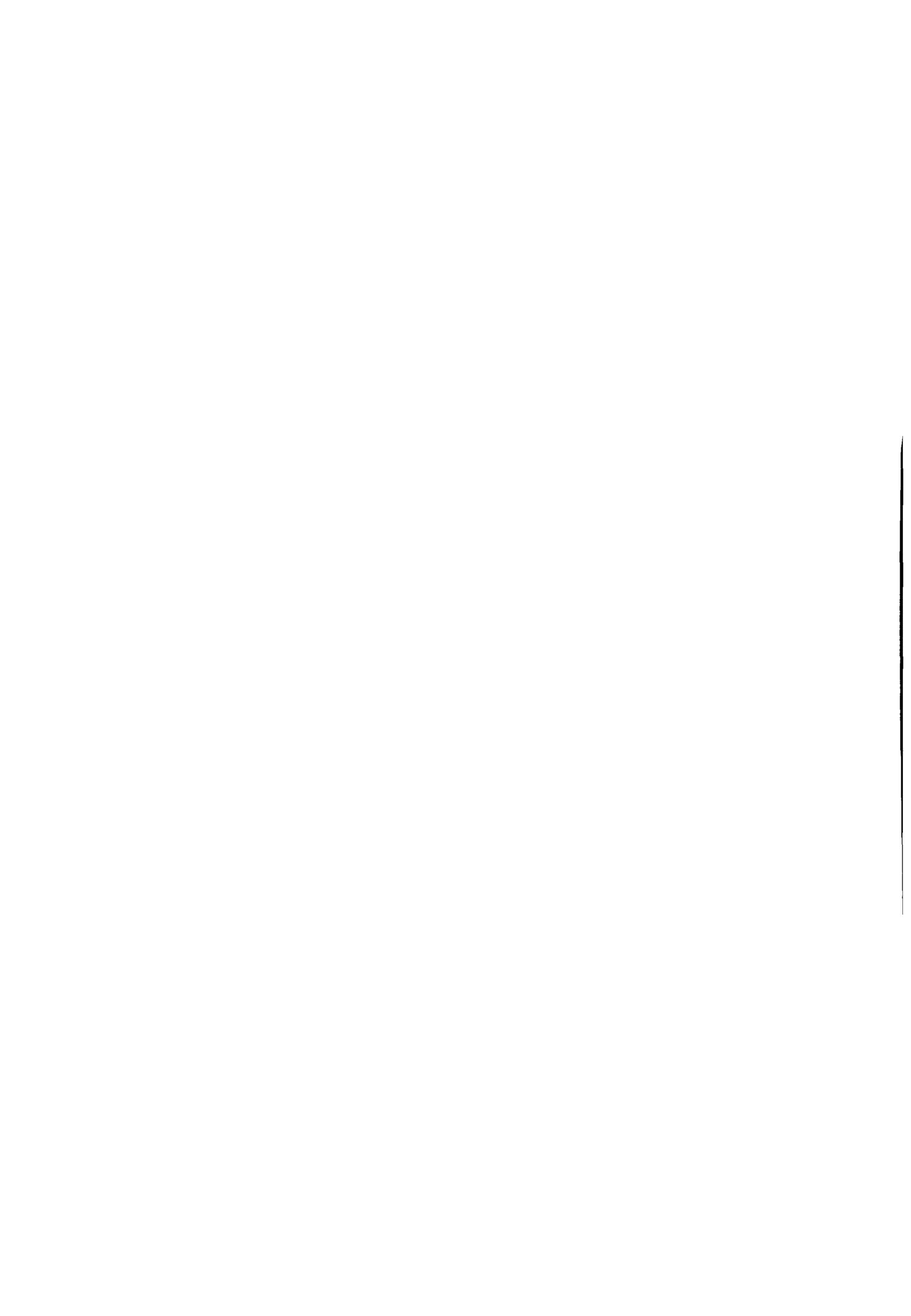

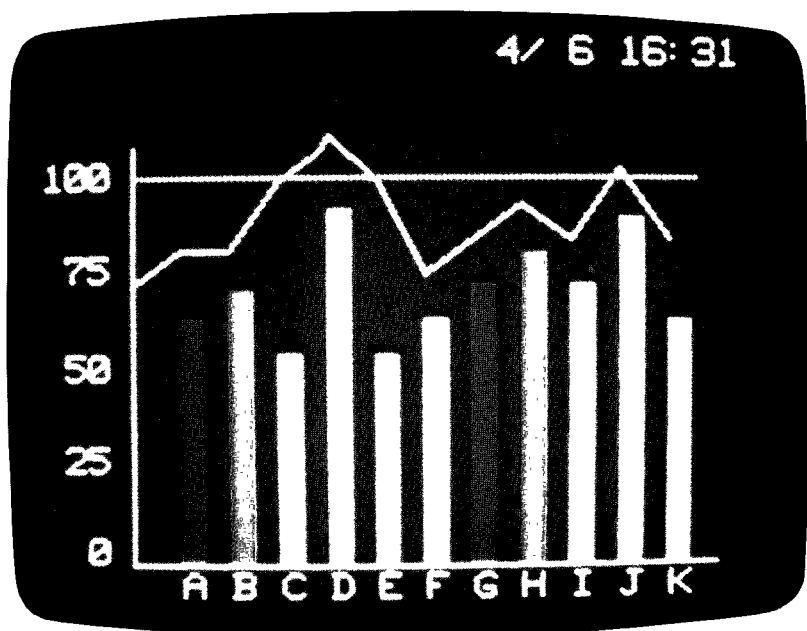

7.1 Bar chart



7.2 Cartography

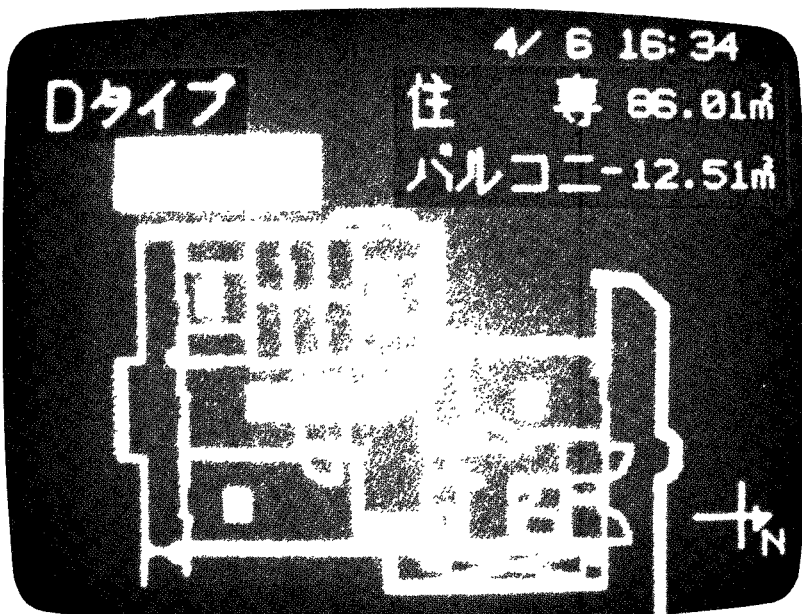

7.3 Architectural plan

## DISCUSSION – Session No. 2

Mr C. LAYTON (CEC Directorate General III, Chairman): There's a very wide range of subjects that we might discuss. At the beginning, there were some challenging things said about the market: i.e., the priority to be given to the business market. There were some challenging things said about European industry... and I hope that you will comment on the readiness of industry to respond to these opportunities, and on their manner of judging these opportunities. Do they share the views of the speakers? Then we had a fascinating presentation on standards, with a very clear proposal concerning the key area for standardization with a view to achieving inter-operability. Now, that's an immense subject in itself, and one of very great interest to the Community, both from the point of view of the users of this new type of service, and from the point of view of the creation of the Community market. Then we had some interesting practical comments about videotex displays. So, who is going to start the discussion?

Mr R. MALIK: After the first two papers this afternoon - those of Mr SCHOLZ and Mr BARNES -, I was beginning to get more and more depressed... until Mr MCGREGOR ROSS took over, with a paper that is absolutely superb concerning the rôle that the Commission ought to play. I feel that the market figures are alright... given that you accept that you begin on the basis of a business market, given that you exclude from the market the whole communications environment, given that the technology can be controlled and restricted to this environment... otherwise those figures have no validity. Up until now, we have been concentrating on the business environment, and maybe that's because most of the people in this room come out of the computer industry. Let me remind you that the computer industry is probably the most competitive industry we have, and what "we need like a hole in the head" is another set of business computer systems out there! There are enough people peddling around the market already! I have been depressed by the fact that nobody has said there's a need for videotex systems, not as a technology, but in terms of what they can do... Comments have indicated that "this really ought to be left to the computer industry, because they have the know-how and the technology, and they can certainly handle the terminal business". As for me, I have very grave doubts about whether the computer industry can handle the terminal industry. There are TV manufacturers here, and they have been building idiot-proof

terminals for the last 25 or 30 years! Europe doesn't need lots of innovations that have no distribution networks behind them. And the people who have very strong distribution networks behind them are the Continental TV set manufacturers. I'm disturbed by another thing. We have been told that satellite direct broadcasting is overrated... but again it depends upon what sort of price level you're going to talk about in terms of equipment. If you're talking in terms of SBS-type ground stations, then satellite direct broadcasting is of course uneconomic. However let me give you an example of a system which has been devised in the States. The company to launch it has already been set up. It was set up three years ago. It will have a terminal with built-in packet-switched interface. The terminal is intelligent, and it will come with a microwave transmitter/receiver, cabling and a two-metre dish. The manufacturing costs of that system, when I first asked about it over two years ago, were under \$3,000. The manufacturing costs of that system when I asked about them in the States this spring were under \$2,000. And I suggest to you that, when we start talking about satellite direct broadcasting systems, the under-\$2,000 costs for a ground station suddenly modify the situation quite a lot. But I'm disturbed by something else. Today, we have been considering videotex in an existing economic and employment context. But all our discussions relate to something that will become important in the middle '80s. So we need an employment scenario. Not simply in terms of employment and unemployment, but in terms of what people are going to do, and where they are going to do it at. It turns out of course, in the scenarios that some people put forward, that a large part of Europe is going to work from home... which would change the market forecasts for all these systems quite dramatically.

Mr J. KANZOW: I think that the main impression that many of us have is that the scope of the subjects being discussed has been too broad, and we haven't been able to follow up all the points made in the various presentations. The various issues raised have been our daily concern for many months, and it's very difficult to do justice to every theme in our discussions, particularly since we haven't had a chance of reading the detailed documents presented to us here. I would nevertheless like to make a few comments on various areas which have been touched upon, and which concern our work in Germany. First of all: How is business interest in videotex going to develop? I have already tried to show that we have very clear domains of text communication which have been identified in the Federal Republic of Germany, because the system concept has to include private computers in our own developments. If we talk of business applications, we must realize that the conventional figures for the commercial area are no longer valid. Data processing, up to now, has always been thought of as restricted to a limited sector. But videotex systems will lead to a great increase in the number of people wanting to use data processing. If we include,

under the term "commercial", people like doctors, insurance agents, and private consultants working in liaison with big firms, for example, then the figures that have been quoted on future videotex usage would appear to be realistic. We are talking of a new target group, not simply domestic users. The situation is totally new, and that explains why - as one speaker told us - the electronics industry is adopting a hesitant wait-and-see attitude towards videotex. Since the others are hesitating, it's the postal administrations who have taken the lead. Mr SCHOLZ said that the European Community should do something with a view to encouraging standardization and regulation in this domain. I have my doubts on this. The national discussions that we have had within the telecom framework are quite novel, because telecom is undergoing very stormy developments at present, and many different areas of society will have to react to these new telecom possibilities. They will affect employment, the mass media... where we are dealing with groups who fear the speedy implementation of new telecom services, because they believe that they will be affected by such new services in some way or another, which they can't see for the moment. And these discussions are coloured by various national preoccupations, so it would be very difficult indeed for national developments in videotex if Europe were to introduce standards. Let me now make a few comments on the presentation of Mr MCGREGOR ROSS. I also thought that this paper was very important indeed. In Germany we consider that everything within the framework of text communication must be seen as a whole. Since last week, there is - as I already mentioned - a CEPT proposal for a videotex standard, and this proposal is worked out in such a way that it is compatible with the basic concepts of text communication. It will now be the task of the CCITT to establish the bases of alphabets, so that what we have achieved by way of standardization can in fact be implemented. The question of using a public network, raised by Mr MCGREGOR ROSS, has also been tackled. As for a new standard which would cover all individual standards, this idea is certainly very fascinating at first sight... but the problem remains that it would be a new standard which would have to meet with world-wide approval. It would not necessarily be based on existing standards, if I understand this correctly, so it wouldn't just be a standardization within the PTT administrations, but also within the ISO... and that would cost time, because ISO is already behind schedule. The question of compatibility at the network level, for all sorts of DTEs, is continually of concern to us, because it's a question of general economy. It's obviously much more sensible to have a common, general, basic standard rather than paying the additional costs of all sorts of computers within the PTTs. And I think that this is the case with the new CEPT proposal. Let me make just one final remark on the subject of DTEs. I am against what has been said about integration. It's probably true that a highly integrated keyboard/terminal would be interesting for business users, but not for private users. There is such a diversity of



uses... and this question of integration should, I think, be studied in greater detail.

Mr H.D. SCHOLZ: I would like to explain to Mr KANZOW that, when it comes to the approval procedures at the European level for a proposal, the Commission should actually be able to help us. Of course it would be fatal if, besides the PTT organizations for standardization, we were to introduce an additional regulatory level, i.e., an EEC level. We don't want to do that. Our point is to provide aid, and to give people a sort of European answering service for questions on videotex, so that interested parties with videotex questions would not be obliged to visit separately each of the nine nations. That was the point of our proposal.

Mr C. de JONG: Concerning the integration of the telephone within the TV set, suggested by Mr BARNES and criticized by Mr KANZOW, it's useful to look at things in a historical perspective. Viewdata, at the beginning, was a telephone set connected to a modem and a decoder and then on to a television set. Today, many people think that videotex will be used a lot by business firms, and so manufacturers have suggested that we put the telephone inside the TV. Now, the problem is that it would be quite difficult to speak into your TV set! So the best solution would appear to be a second telephone set for normal business calls. But a second telephone set means of course a second line to the exchange, or a parallel telephone set to the television. And this leads to complications. In any case, by including the telephone set within the TV, one is moving from the initial field of videotex into the domain of data communications.

Mr R. BARNES: What I was actually saying with respect to a domestic interactive videotex set was, not that you combine it with the normal TV set that exists in the home, but that you reduplicate the video aspect away from the domestic set. Our own research has shown that most users, as you say, don't want to "talk to the television set", or clutter it up in terms of its technology and usage for information purposes. Most European TV viewers perceive their television set as a media entertainment device, not as a media information device. What I was actually saying was that, to get the numbers up to an economic level and to develop the domestic market, a cheap device used as a combination, integrated telephone with video display capability for interactive videotex services probably has a better chance of developing in the domestic market than some other device incorporating the television set.

Mr J.M. HARPER: I only wish to speak at a very general level, and to support a great deal of what Mr KANZOW said. One specific point on which I would like to hear the comments of Mr MCGREGOR ROSS was his remark that teletex - without the final "t" - was doomed for trouble in two years' time. But I really wanted to make a more important and more general

point. I think it is extremely important that everybody in the room recognizes that we all share a common interest. The discussion, once or twice this afternoon, has given the impression that the PTTs have a different interest in videotex to some of the other partners represented here at this meeting. I don't personally think that is true at all. The first concern of the PTTs - as I have already pointed out - must be to see the development of new kinds of traffic, and of new kinds of use of their networks. I was a little surprised to see that the representative of A.D. Little, Mr ROETTER, did not refer to the steps being taken to digitize local network distribution systems, and that, in his discussion of satellites, he made no reference to the IBM satellite business system, which is an interactive satellite system... which is very important with respect to the discussion this afternoon. The position of the British Post Office is clear. We want to see the greatest possible generation of new sources of traffic for our network. If that means a diversification and flowering of possible new services and new types of terminals, coming from many different sources, that is a good thing, and not a bad thing, from our point of view. The interest is collective. But, because in general these services will use PTT networks, it is imperative that there be a merging together of the interests represented here in the computing industry with the PTT interests. One of the fundamental difficulties of this whole subject is that these two worlds have been too far apart in the past... and what we are beginning to get this afternoon is a proper and constructive discussion between them.

Mr C. LAYTON: I'm grateful for what Mr HARPER has just said, because I think it's evident that we live in a different environment in Europe from that of the USA or Japan. And one of the very important points of this conference is precisely to bring together the different interests and forces at work - and notably those of the telecom administrations and industries - in order to work towards an understanding of their common interests. These "common interests" can include very important changes, e.g., in their responsibilities and policies about access to the terminal market, and standardization, and the interface between the open market and the common carrier, and so on. All that may be part of it, but nonetheless the communications at the beginning were designed to, and did, communicate the message that here is a massive opportunity, and that lots of people have to play a part in it. So, while I welcome the elements of "contestation" - which, I hope, will keep our debate alive, and bring out the truth -, I think that Mr HARPER's perspective is very valuable, and important for the Community as a whole... which has to both mobilize an understanding of the common interests at a European level, and to appreciate the parts to be played by all the different partners. And I hope we'll get some comments from industry, because we haven't had any yet.

Mr J.F. PEDERSEN: I would like to comment on what Mr HARPER just said. I fully agree that there has to be co-operation between the PTTs and the data processing sector... but not only with the data processing sector, for we also have to co-operate with the users and also with the information providers. But specifically I would like to make some comments on what Mr HARPER said about the objectives of the PTTs. He said that we have to look for new forms of traffic to be carried by the networks. I don't think that's the main objective of the Danish PTT at least. We think that, over the next two decades, the telephone will be the dominant service. Today we have a coverage of 80% of Danish households, and we foresee that, in twenty years' time, we shall have doubled the number of telephone subscribers, which means that we shall have more than two telephones per household. Today we have ten minutes' telephone conversation per inhabitant in Denmark, per day. By the year 2000 we shall have 30 minutes per day per inhabitant. With twice as many subscribers, and three times the current duration of calls, that will give us a very high revenue... although the cost of a telephone conversation is decreasing by 5% a year in real terms. It was said here today that, by 1995, revenues from videotex services would be equal to total revenues from telecom services and from the publishing sector. I do not believe this estimation. I think there must be an error of from one to ten... in that order of magnitude.

Mr J.M. HARPER: We don't wish to start off a PTT argument... but I would like to make one simple point. All the advanced PTTs in Europe - and that certainly includes Denmark - are engaged in creating digital networks. And these digital networks are, by nature, suitable for videotex and data transmission traffic, and therefore the interests of PTTs must be to get those networks loaded with digital traffic.

Mr McGREGOR ROSS: I would like to answer Mr HARPER's earlier question about my reasons for saying that teletex will run into serious problems one of these days. I have already pointed out that the standardization process is a matter of obtaining a consensus. My experience has been that it is unwise to criticize other people's proposals, and therefore I try not to criticize CCITT proposals... All I try to do is to keep on putting forward what I see to be the best. Mr HARPER has asked why the teletex service might run into difficulties, and I think I can answer in the following way. Since the first CCITT proposals were put forward, there have been sixteen other counter-proposals. This is clear evidence that something was not right. It's like the situation of somebody going to see a doctor and complaining of indigestion, and being told by the doctor that he will be struck by a serious illness in two years' time!

Mr J.F. BROWER (Philips, Netherlands): Mr Chairman, you have often invited the industry representatives to come forth with

some arguments and conclusions. First of all, I must add that I am not in a position to represent Philips as a whole in this field. Quite a few figures have been given today on videotex prospects, both in the home and business markets. What is the reaction of industry to those figures? Well, I recently had some experience in optical communications, where we could buy reports having a factor of fifty difference between the positive and the negative proposals. In my opinion, it's still a little too early to believe that, in 1983, there will be 48,834 videotex terminals installed in Holland, as stated explicitly on page 45 of volume IV of the MWS Services report. In my opinion we still need a number of trials: field trials, and trials within business and industry to see what is the user reaction and what are the reactions of the information suppliers. Perhaps that's one of the reasons why certain industries are a little bit reluctant to believe immediately in this bright future. Of course we believe in the future, but it's pretty difficult to indicate the time scales. Most European industries would have to invest quite a lot of money in this videotex business. Like many of the multinational industries, we are confronted with quite a lot of plans and trials in different countries. We don't believe very much in one unique solution for all the countries, i.e., a European or world-wide chip. In my opinion, there will always be very sound arguments for remaining different in some countries. Not all countries are in phase today as far as videotex developments are concerned, and that can influence the requirements for chips. Another comment. Today we think in terms of LSI and even VLSI technology. That means that you try to integrate more than just the decoder. Perhaps you want to also include the modem, in countries where that is allowed. There again, one has an opportunity of being different. I recently made an analysis of modem requirements for Viewdata, and I found that, even though there exists a good definition of 1200-bps modem specifications, all the requirements were essentially different. That's based mainly, in my opinion, on the influence that PTT administrations have on the networks. How far is the data base from the subscriber? What are the data bases which have to be reached by the subscribers? So I don't think it will be easy to reach European or world-wide standards. There is quite some money invested in the telecom networks, and I believe that we shall have to live with several different standards.

Mr H.D. SCHOLZ: I would like to comment on what Mr PEDERSEN just said. We have been talking about orders of magnitude, and what was meant to be said was that the present-day volumes, the present-day revenues, of telecom carriers and publishers, combined, compared with the 1995 reference and plus scenarios, are indeed in the same order of magnitude. Now, if you project (and most people do in fact project) that there will still be considerable growth in the traditional telecom carriers' business, then that moves on as well, so you will still have a differential further out. But if you

compare the present-day value with the projection, that is what you get. May I also come back to a remark by Mr MALIK, which struck me as getting very much to the heart of the matter. He pointed out, among other things, that there is quite a dichotomy - concerning what is going to happen, and how one looks at all this - depending upon whether one views videotex as just another branch of the computing business, or whether one views it as quite a new thing that comprises a good deal more than traditional computing. In our work, we have come around to the point of view that, if one only views videotex as another branch of the computer business, then this wouldn't carry very far. The really interesting developments are remote from traditional data processing. Mr KANZOW has pointed out that the computer industry looks upon videotex in a rather "stand-offish" manner... and this is rather easy to understand, because we are likely to observe a very serious shift in the revenue base. Instead of terminals that used to cost tens of thousands of dollars, we are now talking of prices of a few hundred dollars.

Mr R. MALIK: Really, what I want to find out from Mr SCHOLZ is whether he believes that this "reference scenario" - which is a sort of medium point - has some good relationship to a possible reality. I speak with feeling, having had a look at what can be called the "scenarios" in the past. Hewlett-Packard produced scenarios of this kind several years ago, at a time when they had the calculator business all to themselves. And, as we all know, their scenarios were entirely wrong!

Mr O. TCHERNIAK: Initially, I would like to support what the representative of the German administration said about the rôle of the CEC as far as videotex standardization is concerned. Above all, I would like to reply to the debate that has been going on about videotex estimates and forecasts... which seem to ignore French intentions in this field. The forecasts given by Mr BARNES - and he stopped, quite prudently, at 1983 - and by Mr SCHOLZ indicate a quantity of terminals which is far smaller than what we have envisaged... and not only envisaged, but actually decided at the level of the French administration. So, let me recall what the French administration, aided by manufacturers, intends to do in the near future. First of all, as Mr KOHN said this morning, a trial will be carried out in the Paris area. This will be a simple penetrability test, to take place in 1980. But the real development of videotex will begin in 1981 with the launching, in the Ille-et-Vilaine region (in Brittany), of an integrated black-and-white small-screen terminal. Initially, this terminal will enable all the subscribers who have it to access telephone information, and will thus lead to the elimination of the paper-based telephone directory that we use at present. When this experiment takes off in 1981, it will cover between 220 and 250 thousand subscribers. The service will be installed free-of-charge, with no additional cost of installation or

telephone rental. And, over a period of some ten years, this service will be offered to all French subscribers. This means that, by 1985, about ten million subscribers will already have such a terminal. And by about 1992, the whole system will be covered with about 30 million subscribers, i.e., all the French subscribers. This terminal will initially be used for the phone directory. The system must be viable, above all. We want to do away with the paper directory over a period of twelve years. An increase in charges would contribute to making this an economically viable operation, but it would also lead to a better service and this would make it far easier to obtain telephone information than at present.

Mr R. BARNES: I would like to comment on what Mr MALIK said earlier about the computer industry. Our study refers in a way to general human nature. The point about markets and marketing and forecasting in general is that you have to look in the existing infrastructure of sales methodology: how products are brought to given markets. At the moment, I don't see any real evidence in European markets of television manufacturers, for example, marketing to the business community in any large way. I do find that firms such as IBM, and elements of Philips, and ITT are in fact marketing to the business community in a big way. So therefore, unless the problem of distribution of a low-cost item is suddenly transformed into a retail environment, the way the consumer television market is done, it is highly dubious, even at the personal computer level. Already in Britain, we have evidence of very large companies such as Esso and ICI and BP going out and buying personal computers. Whether they would do this on a videotex application is highly unlikely, for no other reason than the fact that it has to be connected to the network by someone, either a PTT engineer or a representative of the manufacturer. As far as communications systems and buying habits are concerned in the major companies throughout Europe, those decisions are still made predominantly by data processing managers... who have been elevated in many cases to the title of director of information processing. The point is that most of these people have a background in computers, and prefer to remain faithful to suppliers they feel comfortable with. So, for reasons of human nature, the market is likely to go that way. It's not for me or anyone else to say whether this is the best way.

Mr K. PANDEY (Texas Instruments, France): Like Mr BROWER of Philips, I too am very perturbed to hear this talk about a standard "Euro-chip". We have heard so much about different markets today, all the way from consumer markets being served by TV manufacturers through to telecommunications markets. We have heard about systems. They started off with restricted capabilities, such as in Teletext and Viewdata, and have evolved into Antiope, Telidon, Captains... and perhaps we should be talking about interactive computer graphics. Really I think we should attempt to look more closely at the market

we are trying to serve, because I feel we are trying to cover too large an area, and we shall be unable to reach conclusions.

Mr M.L. FORD (United Kingdom): I am the Deputy Director of the Prestel service in the UK and, like my colleague from Germany, I find it very hard to know what to pick out of the very large amount of information we have been given today, to comment upon. With regard to the market, I disagree completely with Mr BARNES when he said that we ought to forget about the domestic market for five years. We have designed a system aimed precisely at the domestic market. We have built into the system such major design factors as ease of use and low cost. And ease of use is very important because we are trying to break down, or get around, the psychological barrier that exists with so many people when they think about coming up against and using a computer. We believe that our system must be very simple to use in order to become a popular service. While it is very simple to criticize the rather cumbersome numeric and tree-structure approach in Prestel, I believe it is a necessary first step towards getting the general public - both business and domestic users - to accept videotex. I believe that videotex is an information system that can reach and cater for the domestic market... and it is probably the only information of its kind. Many other computer-based information systems exist; they use highly sophisticated data networks... but they are all aimed at the business market. Videotex can and should meet the domestic market, certainly in the long term. And it's our firm belief that we should aim directly at the domestic market. This isn't to say that we are going to ignore the business use of Prestel. I believe it's going to be a very important part of our revenue in the early years. In fact, it's very difficult to determine where the difference between the two lies. Does the independent architect or farmer, who wishes to use videotex for his business, really want something different when he chooses to use videotex in his domestic environment? I suggest that he doesn't; he'll use the same terminal, and he's going to be very happy to use this as his television set... particularly as it could then become tax deductible! It is essential, in developing these things, that we take a very broad look at the market. I would like to conjecture on what the size of that market is. We are very optimistic on it, and one of the impacts of our forecast is that we expect, by the end of next year in the UK, that there will be more Prestel terminals than there will be public telex terminals. We have talked a lot about international standardization, and I suggest that we really need to ask: What do we want standardization for? I fully support the need for standardization in the terminals, as a widening of the manufacturing base will bring costs down. But I wonder how many times an Antiope subscriber is really going to want to access the Prestel data bases. Is there really a market for that? And, if there isn't, do we really need to make standardization decisions and

arrangements? I do believe that we really do need to look at the market for all these facilities. When we carried out our pilot trial of Prestel in 1975, we tried out a whole heap of interactive facilities such as computing, message systems and so forth, and we proved that it's quite possible to do such things. On the public service that we have in the UK now, we have not introduced many of those facilities. We know we can do them, but we want to feel our way into the market with a basic information retrieval service with limited interactive features. Some of them are included, but we feel that we would swamp the system by introducing all of them. So, when you are considering the Prestel service, and comparing it with other systems that are still very much in the pilot trial or experimental area, please remember that we have made deliberate decisions not to introduce certain features into our system for a public service at this stage, but they can well come in... and we would expect the system to evolve, over the years, into something very much more sophisticated.

Mr J.K. POVALL (Plessey, United Kingdom): I would like to express the point of view of another manufacturer... particularly in the same sense as Mr FORD. One of the questions that has been raised is: What's the difference between a business market and a private market? One of the answers may depend upon who does the manufacturing of the terminal. The domestic market is almost certainly going to be covered by the existing television manufacturers, adapting their sets to videotex use. This is a problem area for them because they're in a very price competitive market, and that might explain the reluctance of manufacturers to start developing videotex terminal sets at this stage. As far as the business market is concerned, I feel quite strongly that it's companies like my own - the standard communications manufacturers - who are maybe going to be interested in producing business terminals. These will certainly look very different to the large-screen colour TV sets, which would no doubt be divorced from the telephone. I suspect that, in the business area, a small-screen black-and-white (for cost reasons) television set with an integrated telephone hand-set may be the way things will go. Mr BARNES made the point that colour is to be preferred... but, for the reasons I have just said, I do believe that there are market sectors where black and white would be preferable. If you are selling an individual terminal, the cost of a colour tube is difficult to justify, and cost is certainly going to have some impact on how quickly the service penetrates. Mr BARNES also suggested that standardization would help to reduce the price. My own feeling is that it would certainly have the opposite effect. The price reduction would presumably result from volume production of components. I think that the UK market alone is large enough to lead to major reductions of price in the case of volume manufacture of components, although some small improvements could perhaps be made if you could have a slightly wider market. I doubt whether this would be significant in the overall cost of a videotex



terminal, in which the plastics and the television tube and the manufacturing labour content would be the dominant factors. On the other hand, standardization would certainly be counter-productive in a number of ways. We are already seeing here potential delays in the introduction of the system due to the arguments that we are starting to get involved in, on how we should standardize.

Mr C. LAYTON: There has been a debate today about which comes first: the domestic or the business market? Several speakers have pointed out that the two markets are becoming inseparable. And it has been said that there are all sorts of people - consultants, architects, doctors, farmers, individual retailers, etc. - for whom the business and the domestic markets merge together. This debate was most useful, and I think the Commission agrees with Mr FORD that one must take a look at the markets in order to decide what is required by way of standardization. I think that the paper by Mr McGREGOR ROSS represents a very important attempt to get to the heart of some of the standardization problems, and I'm sure that the PTT representatives here will study this paper and compare it with the important efforts being made within the CEPT. The task of the CEPT, the CCITT and ISO is to reach agreement on what are the essential standards or harmonized features in this area... and I would like to emphasize those words: the essential, minimal standards or harmonized characteristics which would be necessary for effective international inter-operability. Now, the Commission is interested in all that has been said about standardization. We certainly have no wish to deal with standardization, ourselves. Our policy is that we want to see standardization work effectively implemented by the existing standardization bodies. We want to be sure that this is done, and done in good time, and that's why we've been glad to hear of the important steps carried out in the CEPT. The reports presented today contain another message, namely, the importance of all these other areas of activity which can help to generate an open terminal market. We are already in discussion with the PTT administrations on this matter. It is clear that this particular application, like the much wider range of new services which are in prospect today, does open up a new kind of perspective for a massive terminal market, part of which was defined in the papers today, and one in which a great deal of innovation and development and new jobs can be generated... but which will require a great deal of work in order to create the conditions in which it becomes easy to attach terminals to the network, and create a market which is open at the European level. Mention was also made of "regulation". Now, I'm not quite sure yet what that means; perhaps this will come out in the discussion tomorrow... but I suppose it's a reference to the relationships and the areas covered by the monopoly of the telecom administrations and the broadcasting corporations and the free press, and also the areas covered by independent enterprises that may form no part of a public monopoly. It was said, too, that there are

fierce national debates on this subject going on in several countries. This is an area where cultural and constitutional differences will be of great relevance in the Community... and it's an area which we cannot ignore, at the Community level, if we're looking towards the shared objective - shared between the Commission and the PTTs - of providing a range of harmonized services in Europe. The Community would like to do what it can to overcome the obstacles to the rapid development of new services and of new markets. One final comment. Certain presentations today mentioned the Community as a potential user of these kinds of services and facilities. I think that this idea is near to our hearts in the Commission. The Community is an immense "paper machine" at the present time, and we do find these new services and their potential extremely attractive, and we do believe that the Community as an information system could be a much more dynamic "test bed" for some of these new services, exploring the facilities that are possible, and making use of them. This would put us in the position of a catalyst with respect to the future possibilities of collaboration between the PTT administrations and European industry. Thank you very much for your lively contributions. Tomorrow there will be more time to carry on with the debate.

## SECOND DAY OF THE CONFERENCE

*Mr. G. Anderla, Director, Information  
Management, CEC Directorate General XIII*

Our job today is to continue the discussion of yesterday, concentrating however on some key points. In order to find out whether, and to what extent, we can arrive at some kind of convergence of views. My job, with the help of Mr SOMMERLATTE and Mr SIMPSON, is to provide a framework for the discussion, not to influence the views. I propose to do something unorthodox, to depart from the prepared script, the agenda, and to do so in the light of yesterday's discussions. But first let me make several introductory remarks. <Mr ANDERLA tells an Irish joke. The gist of it is as follows. An Englishman driving in Ireland stops at a level crossing of which the barrier is half open and half closed. He asks why. The Irish level-crossing guardian replies: "We are half expecting a train from Dublin."> Yesterday's discussion showed that the various participants here are sort of "half expecting" something to happen. This uncertainty arises from many factors, areas and reasons. As Mr KANZOW said, this subject is so complicated, even today, that no single person can hope to comprehend the whole problem in its complexity. There is a lingering uncertainty about what your distant competitors - in the Extreme East and the Far West - are going to do. Are they going to reap the benefits of your pioneering efforts? There's uncertainty at the level of the telecom facilities providers. A lot of uncertainty surrounds the users. This is particularly true at the level of those who must be mindful of cash flow ratios, returns on investments, and that sort of thing. I have every sympathy for them, the industry people. But I think the first objective we should agree upon is to somehow reduce the areas of uncertainty for all of you. I think this conference alone has started doing that, first of all by bringing all you people together. Never before has there been an exchange of views as broadly based, geographically, as this one. Exchanging information is part of the process of reducing uncertainty. According to the impressive volumes, of course, we find - in spite of many reservations about mathematical modelling, or about estimating a set of figures - that our consultants (who represent one of the finest sets of consultancies that there are in Europe) have put many years into this work. And you will no doubt discover in these volumes a number of things which will simply attract your attention and make you think twice. My next remarks concern the rôle of the Community - or rather of the Commission, its executive organ - in this field. I will be very outspoken on this question, and will try to clarify our position.

Suppose there had been no conference like this one. After all, the Commission was under no obligation to call one. Things would still proceed, and you would still be developing your technologies, your equipment, planning for the future and so forth. It seems obvious that, in this particular context, one should add to the usual conflicts (short term interests, motivations, etc.) the extra problem arising from the fact that the decision centres on which the future will heavily depend are widely dispersed and that, perhaps with the exception of France, there is no mechanism for bringing these forces together. It's not so obvious that, through the sheer market mechanism, some kind of co-ordination might be brought about. This is perfectly conceivable, and I think this might be the outcome of this conference, to conclude that there is no rôle for the Commission or the Committee to play. Let us be crystal clear on this matter. First, there is no obligation for the Commission to play any rôle arising out of the existing treaties or agreements between the member countries. In the Treaty of Rome, of course, there are certain policies which must be implemented, in industry, in customs, in agriculture, etc... and there are subsequent agreements, or council decisions, but there is not even the slightest outline of a telecommunications policy. So, there is no obligation for the Commission to intervene. In our view, the Commission should not intervene if somebody else can do the job. It is not designed to supersede or duplicate national policies, or national efforts. Nor is it designed to supersede or duplicate efforts at an international level. (I'm clearly referring to the CEPT, the CCITT, ISO and other bodies.) The Commission's involvement can only be the result of a consensus of opinion. It must be requested by a significant majority of the partners. And if the Commission is to become involved in these matters, even then it can act only within certain limits. It has no particular competence for proposing standards, but it could of course urge the standardizing bodies to speed up the process. This is just one example. Now, let us turn to the outline of this morning's proceedings. Mr SOMMERLATTE, of A.D. Little in Wiesbaden, will try very briefly to create a bridge between yesterday's discussions and today's preoccupations. I said that we would depart from the prepared script. If you look at the official programme of the conference, you can see that we planned on two discussions which we visualized, in the preparatory stages of this conference, in the following way. There was to be a sequential discussion of the major issues which, indeed, arose yesterday out of these reports. And we thought we would group them under two headings. First innovation, second standards. (What sorts of standards? Who could define them? Is there a need for standards?) And we wished to take into account the needs of users. Then we thought that, proceeding in this way, during the second half of the morning, we would tackle the other three key issues, under the headings, say, of regulation (copyright, legal protection, privacy, validation of information, etc.), possible ways of co-operation between yourselves, and the

question of whether there should be any kind of joint action or pilot scheme. Last night, it appeared to Mr SOMMERLATTE, Mr SIMPSON and myself, when we tried to draw up the balance sheet of the discussions, that this would not work... that it would simply repeat the arguments of yesterday, and that it would be terribly difficult to prevent anyone from jumping from one subject to the next, from one empty or full box to the next. Therefore, we decided to propose to you - and I think Mr SIMPSON, from PA International in London, was very instrumental in this way - only a very broad framework for discussion. Before handing over to these two speakers, I would like to leave two thoughts with you. It seems to me that two things were missing, or largely overlooked, in yesterday's discussions. First, the chief actor in this videotex context has been hardly mentioned... except by Mr MALIK, in an oblique way, and in a prophetic fashion of course. It's the user, the end user of these services. Everyone, of course, talked about marketing: home market versus business market, etc... but I don't think talking about it in such general terms is sufficient. I hope that our two rapporteurs will help us to see the important, and finally decisive, rôle that the various categories of users will play. The second item which seemed to be missing from the discussion was a crucial factor: the time element, which was hardly taken into account by anybody. It is clear that this is only the first generation of systems. It's like civil aviation in 1920; flying from London to Paris was quite an adventure. The product will have to change, and it's about to change under pressure from the users. There have to be simpler, better and - at the same time - more sophisticated services. So, there you are: one actor and one factor should be added to the long list of items that came under scrutiny during yesterday's discussions.

## RECAPITULATION

*Mr. T. Sommerlatte, A.D. Little, Wiesbaden*

I would like to briefly summarize the points that received attention and emphasis yesterday. It was said that the various current videotex services and concepts represent a first generation, and that we shall certainly see a new generation in the next decade, which will have different characteristics from the previous generation. It was also said that the significance for the industries concerned on the one hand, i.e., of course, the industrial branches of consumer electronics, and the terminals for the commercial business area will be of a longer-term nature... and indeed too there is significance for the basic economy under the slogan of innovation and employment. The different subjects that were recommended for discussions - partly, for example, direct recommendations to individual authorities, such as Common Market institutions or postal administrations - can, I think, be summarized under six different headings which I would like to sum up briefly.

1 It was suggested that the Commission of the European Communities could possibly take the initiative of promoting pilot studies... mainly for three reasons. First, to promote the development of a European videotex terminal. Second, to create one or several specific videotex data bases which could be of direct interest to consumer groups. Third, the promotion of European standards.

2 The second area was mainly directed at telecom administrations, i.e., access of the user to the videotex service. This should be as inexpensive as possible. The income expectations of the telecom authorities would, first of all, be restricted to the existing tariff system. On the other hand, the information supplier should be involved more in the marketing responsibility, and indeed should be incorporated more into the marketing costs. So, this second point is the relationship between telecom authorities and the IPs.

3 Here again, we are concerned above all with telecom authorities, and the question of standards for text transfer... not just referring to videotex, but in general terms. This must be encouraged and developed. Here, specific proposals on coding systems could be created, covering many varied forms of text transmission.

4 There are the links between videotex and existing or

future cable TV systems. To what extent will competition arise? Or would it be rather a complementary situation?

5 There must be co-operation between the parties concerned: PTTs on the one hand, then the different kinds of IPs (data base services, publishers, specific groups of those who provide services, new services) and finally those who actually manufacture the hardware. To what extent could the Commission play a useful rôle here?

6 Finally, there's a subject which, I feel, should be in the foreground of our discussions today, namely the encouragement of better knowledge of the market segments... not just the differentiation between commercial and private use, but a better knowledge of the information products which are useful and necessary. The service is basically the vehicle which transports information to the user, and this vehicle is not as yet very well defined. And one should have, too, a better knowledge of marketing requirements, so we can have full use of the potential.

These six headings cover most of what was talked about yesterday, and I believe that we could discuss - under each of these headings - the possible rôle that the Commission could play.

## FRAMEWORK FOR FUTURE DISCUSSION

*Mr. K.M. Simpson, PA International,  
London*

It is hardly surprising that yesterday's discussion proved to be so wide-ranging and diverse. It is in the nature of these things that, of course, we must diverge before we can converge. Nevertheless, our ultimate goal must be to seek out those areas in which collaboration between the interested parties can be most useful to each of them in pursuit of a common goal... if that common goal exists and can be defined. It's not surprising that we found the discussions so diffuse, because the situation has so many dimensions. The first of these is the obvious one of the nine countries who are represented in the Community as it stands today. The six major interest groups: the PTTs, the IPs (those that we see today, and those that may emerge in the future), the manufacturers, the users, those concerned with broadcasting, and policy makers and those concerned with the processes of government in the Community. So, already we have a matrix formed by nine countries and six major interest groups. We have a further dimension to the situation, which is that of the time frame, ranging from a short-term and perhaps pragmatic need of some parties simply to be told what to do today so that they can get on with it, at one extreme, and at the other extreme, a longer-term view, perhaps even a philosophical view, of the quality of life of the people in the Community, the extent to which information as a subject will become of dominant importance in the lives of the people as we progress from the industrially-based society to a knowledge and information-based society. We have another dimension which is concerned with the subject itself, and the problems of subject definition. Are we talking about information as a specific thing? Are we talking about the wider context of communication in general? There are technical aspects. Are we discussing data, or are we discussing the importance of networks in this scheme of things? Are we talking about the maximum use of a voice facility? There are the legal and regulatory issues, which several speakers yesterday touched upon, and some of which must indeed be resolved in the future. So we have these dimensions to the problem... and the dimension which perhaps really matters most of all is that of the market... and this comes back to the chairman's introductory remarks about the dominant importance of users. Surely, if we do have a common reason for sitting here in this room and discussing this matter, it is to move towards a situation where this market will grow as quickly as possible... to generate revenues, and to generate new services for the benefit of all of us. In



that domain, the user is king. The user is not in the least concerned whether an accented "é" is transmitted as an "e" with an accent later, or whether it's transmitted as one character, or whether it's transmitted as a graphic symbol. He couldn't care less; he just wants to see something that he can know and understand, and get it as cheaply and effectively as possible. So, for the purposes of trying to provide a focus - not in any way a constraining structure - to today's discussions, maybe you would find it acceptable to consider the following points.

1 First of all, the emphasis should be on the needs of the users, and how these can best be met to provide useful services, as cheaply and as quickly as possible.

2 After all, we are here to talk about videotex. We can all speculate about what shape and size the systems in ten years time may be... but essentially we are here to talk about videotex as it has been defined in today's environment.

3 We should distinguish between a short-term situation (by that, I mean the definition of actions that could usefully be carried out within a five-year framework), and a long-term situation... not forgetting how the two relate; in other words, one must try to ensure that what is done in the short-term is at least pointing in what are perceived to be desirable directions for the longer term.

4 Finally, we must try to define what are the most useful and helpful areas of collaboration between the interested parties without the Commission. Supposing the CEC did not exist, the interested parties would still find it necessary to discover areas in which they could usefully collaborate. And then to ask the question: What are the most helpful rôles which the Commission could perform in enhancing those areas of collaboration?

## DISCUSSION – Session No. 3

Mr G. ANDERLA: Unless somebody feels very strongly about a different scheme for our discussions this morning, I feel that Mr SIMPSON's framework is most suitable. To recapitulate the last part of Mr SIMPSON's intervention would lead us to discuss in turn, freely, the following issues:

- 1 User needs, and the adequacy - or inadequacy - of service to satisfy such needs.
- 2 Videotex development, today, can be considered as an ongoing collaboration between many different partners.
- 3 The relationship between the short-term and the long-term approaches to videotex must be examined, and one must remember that we are still only at the first-generation level.
- 4 What are the exact areas of collaboration? And, lastly, are there any useful rôles that the Commission could play, in assisting either some parties or all the parties?

Let us start the discussions on the first subject, therefore: the users, the marketing aspects, how do we discover and identify these marketing aspects...

Mr R. BARNES: Our own firm has recently done research with users and information providers, but it is nowhere near to the extent that it should have been done to accurately indicate where we go from here. The point is that most of the studies that are being presented, and the work that has actually been done on videotex, have not done a great deal in the way of user market research. Perhaps the Commission might be interested in the idea of promoting such research, both in the domestic and business environments. But, in an EEC context, or in a European context - and not necessarily on a country by country basis for those particular services being offered by each individual country, PTT or what have you -, perhaps people here would like to comment on the idea of whether that is (a) either feasible or (b) desirable...

Mr H. DRUECK: I would particularly like to take up the first two areas mentioned by Mr SIMPSON, and ask some very specific questions... because I think we run the risk of getting bogged down in generalities, really. Mr SIMPSON said that user needs are the most important thing, and he also referred

to short-term plans that we should be thinking about, to be compared to longer-term reflexions. Next year, the Federal Republic of Germany is going to be faced with the problems of starting new field studies, and it would be useful to hear from the United Kingdom, which has made the most progress in this area, and to get some further information from the UK so that these field studies might be implemented in the most realistic way. It would be good to have some empirical data from the British. Yesterday, Mr SCOTT said that, after four years of the BBC Ceefax service, there are twenty thousand domestic users of the system. That's a very small figure if you look at the number of households with TV sets in the UK. Why is this? Is it because the equipment is too expensive? Are the services offered not sufficiently attractive? What are the reasons for this situation? We heard from Mr FORD, representative of the British Post Office, that he hopes that, within twelve months' time, they will have more Prestel subscribers than there are telex subscribers in the UK. As far as I know, there are 70 thousand telex subscribers, and less than one thousand Prestel subscribers! So, how does the BPO intend to market their services to 69 thousand potential Prestel users during the next twelve months? It may also be interesting for our publishers to know something more about the realities of Prestel. For example, do you intend to enter, say, the Encyclopaedia Britannica into the Prestel system? Empirical data of this type would be of great use to us.

Mr H.J. BREIDENSTEIN: I would put things in a slightly different way, especially from the point of view of technical press publishers. It's not that we are afraid of videotex. On the contrary, we see an opportunity for complementarity here. The information that might be transmitted by videotex is of a totally different nature to printed material. It must be very terse. It's information that must be expressed in headlines, providing references to the full information that we publish in the classical form. The "threat" brought about by videotex would be found rather in the financial structure of our current publishing industry. For example, in the case of newspapers, it's obvious that the entire advertising part could be transferred to videotex rather easily. There is a threat at that level, but not at the level of the actual technical information itself... so that's why I prefer to speak of complementarity. Finally, I would like to ask our British colleagues to provide us with more information concerning Prestel.

Mr G. ANDERLA: We now have three questions on this subject of the adequacy of information concerning user needs. First, the numbers of users. Second, the content of the information to be provided. Third question: Is it to be identical with the printed material, or must it be presented and edited differently?

Mr M. FORD: I would first like to talk about the market. It

is true that, today, we have 1,080 users of the Prestel system. We expect - or we hope - that, by the end of next year, in eighteen months time, we would have something like one hundred thousand users of Prestel. The main constraint at this stage is the availability of terminals, together with the fact that we have at present only one computer configuration. By the end of this year, we would expect to have something like six customer service computers, each able to handle two hundred simultaneous accesses, and we would expand that during the course of next year. We are confident that the demand from the users is there. We may of course be wrong, but we are hopeful that it is there... and all the indications we have had from our pilot trial and our market trial - and, now, our residential public service, in London - have confirmed, over the last three years, that the market is there. What we don't know is what users want out of the service. We have a feeling that they do need a service. We believe they want guidance as to the type of service they want, and I believe that, over the next few months, we are going to gather a considerable amount of information about what things are popular, and what users will in fact purchase from the system. The only comment I would make at this stage is that the two leading areas of information that customers use at the moment are, on the one hand, financial information, which is used quite heavily, and the other one is games. And it has been very noticeable, over the last few weeks, that the IPs - who, of course, have complete freedom to put anything they like on the system, once they have bought their pages - are putting more and more games on to the system, which people are using. I don't believe this is a bad thing in any way. It allows people to get a feeling for the system, at an introductory level. I believe they will then move away into the field of more real information needs in due course. Turning to the publishing area, we do believe that videotex is a new form of electronic publishing. We, in the Post Office, are not publishers; we don't know that business, and we are not attempting to enter it. What we're doing is providing a medium... if you like, a bookshop... so that the publishing industry can publish what they wish to do so. And many of our larger IPs are publishers: The Financial Times, IPC, the British Printing Corporation, the Consumers' Association, the Birmingham Post and Mail, Eastern Newspapers... They are in that business now. We don't have the Encyclopaedia Britannica, but we do have the Caxton Encyclopaedia on the system. And the Caxton Encyclopaedia is providing information directly from their volumes... but not the complete information you would obtain if you actually read the encyclopaedia itself. As our friend said just now, it's much more terse, concentrated information, which they hope will then lead the user, when he wants more information, to actually go to the printed books. That is probably the more general area in which publishers, for the moment, are using Prestel: to provide information about the contents of their publications, and not actually to give the contents of the publications themselves. They are trying to attract users

to use the written word by explaining what is available to them. And, in the scientific and industrial area, I think that is what is happening in the publishing world. The Financial Times puts up news headlines from its paper each day, but nothing much more than the headlines. The encouragement is to then go and buy the newspaper in order to read a bit more about it... and I believe it works! I would like to make just one more point, in relation to the development of the medium itself. It's very clear that you do need a new editorial style to present information on videotex. It needs to be terse, to catch the eye, not a great deal of text, and it needs a different form of presentation. One of the ways in which we have, ourselves, invested in developing that type of approach is to commission a number of editorial contracts, with five or six journalists or writers, who are given similar subjects, and they present them on Prestel in the most appropriate way. They sat down, and they thought about it, and they imagined a number of very interesting approaches to such subjects as energy, and law and order... that have been developed specifically for the medium. And I believe we will carry on investing in that kind of development. Perhaps that might be something that the Commission could look into: namely, the question of how information ought to be expressed in this new medium. The Commission might invest in the encouragement of original ideas at this level.

Mr R. SCOTT: I would like to answer the question posed by Helmut DRUECK as to the reasons for the slowness of the public response in the United Kingdom to broadcast videotex or Teletext. The main reason, I believe, is that the industry was a little slow, understandably, to create at an acceptable price the kind of chips that were necessary for the decoders, originally, and talking about 1974, some five years ago, one of the members here at this meeting comes from the company, Texas Instruments, which first produced the necessary chips and made the decision to go into mass production. But it's understandable that the industry was somewhat reluctant to embark on a mass development, particularly at a time when the British economy was not exactly flourishing. There was also the fact that the original price to the consumer, of a set equipped with decoder (because the add-on devices were not very successful), was the equivalent of a second colour set... and in many households with sufficient money to spend on a second colour set, say of the order of three to four hundred pounds, at that time, the alternatives then being offered were such things as video-cassette machines, games machines, or even a cheap black-and-white set for the children's playroom... rather than to spend the equivalent of a second colour set on something which was after all still being regarded as a new and interesting, but perhaps not entirely necessary, innovation. So I think that's part of the reasons for the delay. There's also the fact that the service provided by Independent Television was hindered by considerable labour problems and industrial problems which

had to be resolved before it could initiate its full service on a regional basis. We have now a very efficient service offering something like 800 pages (between 600 and 800 pages) on the ITV and the two BBC channels, and - as I mentioned yesterday - the possibility of 800 pages or more when a fourth channel comes into being some time in the next three or four years. Then one could say that the popular consumer market - which requires to know everything from the weather to the times of trains - has been more or less satisfied. Incidentally, I'm constantly surprised by the emphasis placed on this popular market in the context of sophisticated private subscriber uses of devices like Prestel and Antiope. To my mind, weather reports and the news and things like that are essentially part of a public service. But the other question raised by Mr SOMMERLATTE, Mr SIMPSON and particularly by yourself, Mr Chairman, in introducing today's session, is whether or not videotex is a natural need. There are two forms of market development. The first is meeting a natural need, and the second is creating a need and fostering it to the point where people can't do without it, even though they're not naturally inclined towards needing it. In the case of broadcast information in a printed form, it's actually questionable whether it is a real need. It's fun and it's interesting and it's certainly, to the general public, something which men and women are going to get used to, and are going to want to continue to use. It is an extra facility, beyond the radio news, beyond the television news, beyond the information that is supplied in many forms and particularly through the newspaper. It's interesting that the real need which we are at last responding to, with Ceefax, is the need of the deaf. That is a real need... and I think we haven't yet defined other real needs. One should not forget that the entire original development of Teletext in the UK came about as a result of research into various things: research into the use of sound in the "syncs" of the television picture, and research also into the possible use of the information contained in the bandwidth to provide subtitles for deaf people... and to provide subtitles in Welsh for certain people in Wales who wanted their programmes subtitled in Welsh. This, then, was expanded into a full page of information. Apart from developing the existing service on a national basis, and deciding to what extent it should be extended regionally, our current efforts over the next few months will concern this work for the deaf... partly through experiments with Pal and type transpositions to the screen, partly through subtitling, and partly through summarizing the contents of programmes. And I have no doubt at all that the first response to these experiments will be that the highest percentage of new users of broadcast Teletext in the UK will be found amongst the deaf. That will in fact meet a real need... and it comes back to what you were saying, Mr Chairman, at the beginning of the meeting. In broadcasting, we adopted a new invention, and we were delighted with it like a new toy, and we developed it because it was simple, and it excited interest and response... but we did not

actually set out to define the market needs. Indeed, I don't think that the market needs have yet been defined. We have hardly talked about software here - but that's what it's all about... and, looking at the kinds of software available, as displayed on the screen, I get the feeling that nobody quite knows yet what sort of software is likely to meet consumer needs, or indeed to create this new market, which then would become an essential part of every domestic context. After that, perhaps we shall decide that it's not sophisticated enough, and that what is required is some sort of printout, or some kind of store system, to make it even more efficient and even more practical. That's an open question: Is this merely a part-way stage towards cable facsimile? Perhaps too much information is being directed to the householder and the average person. And perhaps the type of information being directed to him is not really the kind of information he requires. Should these systems be transmitting other kinds of information? Should this information be complementary to what the radio and television and newspapers are doing? This is the "signpost" rôle of this "printed radio" that I was referring to yesterday.

Mr R. MALIK: Contrary to some of the opinions I've been listening to over the last day and a half, the user is not a mythological beast. I myself am a prospective, would-be user of these services, and I'm willing to pay. Now, I made some remarks yesterday which were broadly political. If we look at the future of Europe, it seems to me that the current political scenario is ripe. We are watching a reversal of the trend of the last twenty years, by design or by the wishes of people. We are bound for the era of the small business. We won't go into the reasons why this should be so, but this does seem to be happening. Now, what is the small business worker going to be? He's going to be an information worker. (I happen to be one already.) What does the small business information worker want? First of all, he wants time-independent services... whatever those services are. (There's one snag about working for oneself. There's no such thing as "social hours", as they say in England. We don't "knock off" at five o'clock.) He wants to be able to manage his money, his resources, his cash flow. The small businessman wants exactly the same thing as the big corporation managers get... which is the maximum velocity of money IN, and the minimum velocity of money OUT. These considerations lead me inexorably, in a videotex context, down the road of a set of services which are a mix of information retrieval and communications. I can't - in some ways - separate one from the other. I may say I'm not talking in a vacuum; I have a lot of aids at home, including a facsimile transceiver, a couple of phones, a computer, a Teletype which gives me access to computer services... and still it's all unsatisfactory; still I haven't got what I want. Well, what do I want? I need current data; I need current statistics (you see, I don't happen to have an assistant who could go wandering around and dig this stuff

out); and I need this now, while I'm thinking about it, because there's nobody there to pick up the pieces thereafter. Most of the reference books are out of date, because of publishing cycles: they always are! I need financial information, and I need that fast. I need interactive communications, preferably with paper. One of the games I play with my facsimile transceiver - and, believe me, it's a very expensive game to play internationally, in Europe, at the present time - is to send a copy to Paris, and it comes back to me scribbled over, and I send it back scribbled over, and we carry on this interactive game on paper. We could just as easily do it over VDU... but I need it, and I need it very cheaply. Since one is operating from home, obviously the same facilities are going to be used for home services. Now, what home services does one need? Well, let me give you an example of the home services that we really haven't got yet on Prestel. I need a good encyclopaedia which has some relationship to the examination syllabus... because, however good or bad one's education, all of us who have children at school encounter the same problem. I'm sure that, during term time in Great Britain, there must be at least a million parents a day who are being asked questions they can't answer! And they're ashamed about it, and they send them to reference books, and the reference books are useless... and this goes on all the time. There's a huge outlet for this market. You see, I've now mixed up a personal service - one specific personal service - and some business services which I have to have when operating from home. There may be millions of people like me!

Mr G. ANDERLA: I think we have moved some way from yesterday's discussion on this topic of user needs. In fact, yesterday there was a contrast made between the domestic market and the industrial user. It was not properly discussed in that nobody really proposed a definition of what is the difference between these two markets. Mr MALIK is now suggesting - and it's new - that, instead of having this dichotomy, we look at the market as a fixed number of segments. He's really, in fact, suggesting that the right approach might be a segmentation of the market.

Mr K. PANDEY: I do not, as some people might expect, regard Mr SCOTT's statement - about the cost of components or the cost of equipment - as being a challenge in any way, or as being in any way disparaging. I'm very glad he has made that point, because I think it's very relevant to appreciate, at today's meeting, that these costs are inevitable, and can only come down in a certain fashion. Now, all efforts to modify systems and produce new standards are going to bring us back to the starting point, and "up the learning curve", as they say in the semi-conductor industry. Therefore, since the UK industry was not in any way subsidized, but had to make a commercial proposition of it, unlike the PBS service in the States, and in France today, these prices had to come down by volume. The volume does not exist instantaneously,



therefore they could only come down in a certain fashion. Today the prices are realistic, therefore we are on the exponential part of the market curve, and the market - as Mr FORD has pointed out - is going to increase very rapidly now.

Mr J. THYNNE (United Kingdom): Mr SIMPSON, when he listed the half-a-dozen interested parties in videotex, at the beginning, mentioned the rôle of government as a policy former. In the UK we see our rôle as wider than this, and it may be of interest to some of you to see the ways in which we envisage that broader rôle. We see ourselves, for example, as an information provider within a number of government departments. We have tried to improve the government/public interface, and to use Prestel to communicate information across that interface. For example, in the Department of Industry, we have various industrial support schemes, and these are perhaps not as widely known to industry as they might be. We have taken pages on Prestel so that the industrialist can call up Prestel and see what kinds of support schemes we have, and see whether his particular interests are catered for by our support schemes. Mr NICHOLAS mentioned, yesterday, the Ministry of Agriculture's scheme whereby technical information to farmers is provided. The Department of Employment also provides information to the public. We see this just as a beginning, because it is a very powerful way of communicating information directly to the people who wish to take advantage of that information. And I see a major expansion of the rôle of government as an information provider. But it is not only the government/public interface that is important, but also the interfaces within government. The transfer of information from one department to another, or even within departments, is also important. In the UK, now, we have an inter-ministry working group which is considering ways in which Viewdata could be used by government departments, not only within the departments themselves, but also to transmit information between departments. This group is active now, and we hope to come up with various recommendations later this summer. To give you an example of the ways in which we might be able to take action, let us think of the Department of Employment, and the Manpower Services Commission in Great Britain. There are something like two-and-a-half thousand job centres located throughout the United Kingdom. People can go there and find out what sorts of jobs are available, not only in their region, but throughout the UK. It seems to us that, if Prestel sets were installed at a large number of those job centres, this would provide the person seeking employment with rapid information on the jobs available, not only in his own locality, but also throughout the country, on a much wider basis than has been done before. It would also enable the job position to be updated very regularly, so the unemployed person will not have to wait for advice by mail concerning job opportunities in remote parts of the country. He will in fact know that, today, there is this set of jobs available in this particular region. So I think this could be

a really powerful weapon in the hands of the Manpower Services Commission. Other areas in which videotex might be used are citizens' advice bureaux. In the main streets of many of our large towns, there are offices called "citizens' advice bureaux", and there the citizen can go in and seek information. Prestel sets installed in these offices would enable people, for example, to ask specific legal questions, or to look for advice on how to buy a house, or that kind of matter. Hospitals and schools (there are, I think, something like 25 thousand schools in Britain) could benefit from Prestel. The possibilities offered in terms of teaching, in terms of career advice, would be really tremendous. The Open University has been really active. So I would like to say that we are thinking, in government, of our rôle, not only in terms of policy forming, but in fact very actively in these other senses.

Mr U. MONACO (Italy): I must confess that, this morning, I am still more perplexed and uncertain than I was yesterday... and it's difficult to say at this stage whether the barrier on Mr ANDERLA's Irish level-crossing should be open or closed, i.e., whether our administration should open it or close it. But I would like to thank the Community for providing us with this opportunity to discuss these problems and, above all, this food for thought and study... and for having given us this opportunity of listening to the extremely interesting statements made yesterday, and some of this morning's specific ideas. I would like to give you a little information about Italy. Videotex is a very important and a very interesting subject that involves complex problems of a technical, social, economic, industrial and political nature. We in Italian Telecom feel that we have a very important rôle to play at the present moment. A committee has been set up in order to specify the background for the new system that we are also planning to introduce in the near future. We are defining the needs and requirements, because these services are something which, we feel, will expand very rapidly in the years to come. As Mr SIMPSON said, the user is king... and he will certainly try to make maximum use of the powerful instruments of communication we give him. There are certain technical problems that must be solved, in conjunction with the solutions already adopted by other countries. For example: Should we have an alphanumeric keyboard? Should our modem be integrated? Etc. But these are not the major problems that concern us, because we feel that we shall see progress in this area once we have a public data-transmission network available, and, above all, once we can make use of domestic satellites. We in Italy, as in many countries, have a number of private networks: the banks use their own networks for stock exchange quotations; there is an information network for the courts of appeal and for legal services; the travel agencies almost all have their own networks and their own services... From the data made available to us, we have concluded that the major potential users of these new services are the financial services and

the transport and travel services, although we must recognize the fact that these new systems could be used for education, too, in the schools and universities. Now, the proliferation of all these private networks took place because, we admit, there was no adequate public network that could meet the information needs of these users. But today - when we have improved telephone connexions and telephone networks, and when we have public specialized data networks with switching systems and packet switching - we feel that these public services will develop making use of these new networks. What happens? When you have the terminal that is linked to a specific network, these can be replaced thanks to technological development by a video screen, and then, on the one hand, you have the business sector which can make use of terminals linked in to the data broadcasting system, and then you'll have the private sector which can make use of the video and the telephone switching network. Therefore I personally feel that the development of these new services will be very much affected by the development of networks, and above all by the introduction of public networks for data transmission and by domestic link-ups through satellite. And therefore we must look at the problem, not from a technical angle alone, but also from a political and social point of view. With this in mind, I would like to draw the attention of those who are responsible for management to the fact that they will have to make certain decisions... because, in my view, the Community could play a very important rôle here. That is why I would like to thank the Commission once again for having taken this initiative. First of all, we have to establish an order of priorities. Which services will be introduced with priority? There are tremendous possibilities opened up by technological development, and a number of services can be provided to the user. You can tell people about the weather, the financial situation, traffic conditions, and so on. Therefore I feel that, first of all, there should be an examination of priorities to be established. What services should be supplied, and when? And then you have to decide how... In the light of what I said previously, therefore, I find it's difficult to forecast the development of these services over five or ten years, because the evolution of these services is linked to the development of networks. And there are the related problems concerning the management of data bases. Some of these problems concern individual countries, and therefore call for national solutions... but there are other problems at an international level, that involve the Community, and they concern the EEC. I would therefore like to make a proposal. The most urgent problem is that of harmonization and standardization. In my view, if this problem cannot be resolved within the EEC we should call on international bodies - the CCITT and so on - to complete their work on the standardization of these services, which are things that have been almost achieved. And a number of nations have taken very decisive action as well. Therefore the problem of standardization is a fundamental problem, which should be of concern, above all,

to the countries of the EEC, because we must avoid seeing the industries of the East and the West invade the European market. Once we've defined the problem of standardization, then, at the level of the Community, it's also necessary to establish a list of priorities. Which services should be provided at a Community level as a priority? To this end, I feel that we should pay attention to the proposal put forward yesterday, and mentioned by Mr SOMMERLATTE, suggesting that the CEC start out a specific pilot trial in videotex making use of Euronet. This would be a means of encouraging administrations to look to the problem of standardization, and to reflect upon the priorities of services to be provided within the context of the Community.

Mr J.M. HARPER: I have two questions which I would like to ask. The first is very simple. I accept the concept of market segmentation, I accept that it is correct to push the discussion towards the idea of market segmentation, and I accept - for the sake of my question - Mr MALIK's definition of a market segment consisting of the domestic user and the businessman working from home. I was very struck by a point made by Mr SCHOLZ, yesterday afternoon. He seemed to be very certain that the addition of a European dimension to national videotex services would considerably stimulate their growth. I would like to ask him to expand on his reasons for being so certain about that. And I would put the question in the concrete form, as follows. In Britain - as in other countries - we are faced with the possibility of developing videotex for the market segment I have just mentioned, and this will certainly take place in the course of the next two or three years. There is therefore a concrete question as to whether the addition of information available at a European level, as distinct from a national level, would help to stimulate growth in that particular market segment. That is my first question, which I hope Mr SCHOLZ will answer. My second question is much more difficult: What is, in any case, the difference between the business market for videotex and the residence market for videotex? I have no clear answer to that question, myself, except for one thing. It seems to me that the business market - and in this case I mean the market of the big firms and the medium-sized firms - is very much more experienced, it is very much more educated, it is accustomed to the use of VDUs, it is accustomed to the use of information retrieval systems... It therefore can be expected, in principle, to know what it wants. The residence market, on the other hand - with the exception of people working from home like Mr MALIK -, is certainly not so accustomed to information retrieval systems, to VDUs, to data systems generally. It therefore does not know what it wants. And I suggest that an important difference between these two markets is that, in the business case, the PTTs and the other people can go out and find out what the market segment wants, whereas, in the residence case, there is more a problem of introduction of education, of publicizing the possibilities... so that people can begin to formulate the

questions to us.

Mr CHAMBAUD (CIDST): My remarks will complete what Mr HARPER had to say, and this will enable Mr SCHOLZ to give a general answer. In the statements made today, in particular by Mr SCOTT and Mr FORD, we have seen that the introduction of these new technologies to the market at a national level does pose a number of major problems... and it's not terribly easy to suggest solutions. Furthermore, yesterday, the question arose as to whether the Prestel system had a market outside Britain. In the light of these questions, I think we can then ask about the extent of the European market as such. And we should ask whether it isn't rather a national or a regional market. Perhaps we can put the problem in slightly different terms. Are these systems going to compete with present information broadcasting systems, or are they going to serve needs that are not served at the present time?

Mr J. KANZOW: Listening to this morning's discussions, I was reminded of something that was said a long, long time ago: "I know that I don't know anything." A characteristic of the discussions, both yesterday and today, is the fact that there are no differences of opinion as to the market. Videotex systems are so broad in their use that we can talk in depth about any particular area within that broad scope. I would like to stress something that Mr HARPER said, namely that it is absurd to ask private householders what they would like, without showing them anything. The private user - and I count myself as a private user - is not an "economic being". He is led by desires, habits, customs, influences and environment... and he's not predictable; you can't forecast what he's going to say. We have a one-year field study with a representative selection of private users, a cross-section of areas and regions. But we can already see today that, in such a major field study, we must ask certain questions, e.g., as to whether results really enable us to draw any conclusions as to the further use of the system. This is due to the fact that, despite all efforts to the contrary, what we offer by way of services will not be representative because, at the moment, the supply of information will differ, and it's precisely because of a "teething stage" which will take up several years or even several decades. It's only in the course of this "teething stage" that we'll see where the use lies for a private person. So I honestly don't think it's possible, no matter what method you choose, to say that the emphasis on private use will be situated at such-and-such a place. In the 1977 exhibition of the Rundfunk in Berlin, we asked a number of clients what they wanted. Typically, private citizens were spontaneously interested in this new system, but they were curious to know what could be offered by such a system. And it was obvious that they were going to say that they would use something in an area which they already knew about. In other words, we will have to go through a phase of training people. Obviously, it's going to take some time before a system will be fully used. The

results that emerge from the preliminary stages will depend on the individual characteristics of each country. Various factors will change from one country to another, particularly as far as commercial use is concerned. So, to that extent, I have some doubts about attempts to define a common European field of interest, because I honestly think that this would not be realistic; it would not be facing the actual needs of the market and the developments as such. In Germany we have created two working parties. One brings together potential users. As you know, Germany is a country of federations and organizations, and we have brought together about sixty to seventy of the leading federations: not just those which are currently interested, e.g., the publishers... but we've also included federations which, we feel, could become interested in the future. Indeed, we are aware that we haven't covered all of them. In this context, we are discussing videotex, exactly what it can be, where the emphasis for applications should be laid. The second working group deals with the further technical development of the system. It includes representatives from the industrial and economic spheres. We try to discuss such things as standardization, and we introduce these topics into CEPT meetings. For example, we have talked about the standardization of a simple modem. So, what we're trying to do is to develop a very broad level of activity in Germany, and I assume that the situation is pretty similar in the UK and in France. We hope that we can obtain speedy results, which are absolutely essential if we are to keep abreast of the very rapid developments in this area.

Mr H. SCHOLZ: The question that Mr HARPER asked is indeed more complex than what I could sketch out yesterday, and we ourselves were taken aback by the strength of the response that we got on that particular topic. So, we really have to say that it was the respondents who overwhelmingly stated that there must be an international, or at least a European-wide, standard and, if that were the case, then things would be very much better, and they would view the whole subject in a much more favourable light. Now, our own view on this issue is as follows. First of all, we do not believe, ourselves, that, over the short term - say, over the next three or four years -, it's going to make any factual difference whether there is or there is not the possibility of these systems interworking. However, we would like to point out that, if, in the medium term and certainly in the long term, there is no serious prospect of these systems interworking, then a degree of uncertainty will hang around... because there are different systems in different European countries, and people will all the time wonder what it is going to do to the development in their own region, in their own country. And this uncertainty is surely going to have a depressing effect in the medium and long term. That, in any case, is our view on the matter.

Mr de JONG: We are discussing, I think, three things. First,

there is broadcast videotex... and I haven't heard much about that. Second, there is interactive videotex, for two groups of users: domestic and small business... whereas broadcast videotex is only for the domestic area. And there is data communication for the small and for the big business. It is difficult to draw sharp boundaries between these three fields. As it was said this morning, we first need to consider the coming five years, before dealing with the period that will come after. The equipment for broadcast videotex and for domestic interactive videotex should be the same. If we concentrate on the small business applications of videotex, then we soon move into the domain of data communication... and it's obvious that the distance between broadcast videotex and data communication is vast, so we have to draw the line somewhere. Interactive videotex in a small business would be used to provide information on a national or local scale, and not so much at an international level. For example, think of small businesses in the real estate field.

Mr G. ANDERLA: I would like to see where we stand now. As Mr SIMPSON suggested, I think we agreed to discuss, first, the matter of user needs and adequacy of services with regard to user needs. From there on, we really moved to the question of what markets there are: towards knowledge of these markets, and fact-finding. It seems to me that four major points emerged from the discussion. As opposed to yesterday's simplistic view of two markets - the domestic and the business -, it has been suggested several times that one must adopt an approach of market segmentation. That raises the problem of finding meaningful criteria to identify such markets. A number of them have been suggested. Mr MALIK, for example, started a discussion on the needs of the small business man. Mr SCOTT joined in, saying that there is the market for deaf people. The French in fact implied, yesterday, that they would proceed by way of the telephone subscribers' market. Mr THYNNE suggested a number of additional applications geared to specific categories of users: extension workers in the farming area, employment agencies, etc. Apparently there's a great need to ascertain exactly all the factors involved, to improve the methodologies, to measure the reactions of these various markets... and it was suggested on the German side to start with the kinds of services that are being used, because these are perhaps best replaced by new services. The second thing which strikes me in the discussion is the question: Where do we draw the line between national and international needs? Mr CHAMBAUD raised this question. There are a number of answers, obviously. Here in Luxembourg, we are in a border area, and people typically want to get information from Germany, from Belgium, Holland, Luxembourg and France. Of course the British situation in the Midlands is probably very different. The businessman wants stock exchange information from all over the world, not just from his own country, because he's not obliged to invest only in domestic stocks and shares.

Travellers too are interested in international information. Do you know that there are 240 million border crossings a year within the Community? That's a very large market indeed for foreign information. But there are clearly a number of areas in which national information is the only thing that interests people, and in some cases only local information. But there are no clear border-lines between these different categories, just as there are no clear border-lines between the businessman and the private investor using his domestic television set. Then there was the third suggestion, which came from Mr THYNNE, who spoke of civic services, civic advice, problem-solving devices, educational needs... These must be tailor-made; they can't be taken off the shelf. The previous examples we mentioned used existing information, or existing software, as Mr SCOTT aptly pointed out. The further suggestions of Mr THYNNE would mean developing the product: the carrier as well as the information... and this is really the second topic that Mr SIMPSON suggested to us. And this also leads us to the time-scale problem. I don't think we have very much time to discuss this second topic... on which Mr de JONG in fact made a contribution. I would like Mr SIMPSON to introduce the third big subject, which Mr MONACO and Mr SCHOLZ have already mentioned. This is the time element: What should be done quickly, and what can be done later? This includes the questions of innovation and also of standardization.

Mr K.M. SIMPSON: Perhaps it would be helpful to try and relate the short-term and long-term issues to Dr MONACO's point about harmonization and standardization, which he sees as imperatives and top priorities for collaborative action. I think that yesterday's discussions revealed some interesting and perhaps surprising points of view. It seemed to me that some of those present from manufacturing industries were suggesting, in effect, that there is a danger here in standards, namely the problem of "the best being the enemy of the good". In other words, the manufacturing industries feel that, if they must wait until some trans-national standard is adopted, they may be deterred from taking the steps we would all like to see, to accelerate their rate of supply of equipment to the market, which would encourage the development of that market. This was a suggestion which was made. On the other hand, from the point of view of administrations and others, it is clearly necessary to have some focus on the directions in which standardization and harmonization should be pushed in the longer term. These might relate, for example, to the wider exposure that might be given to the proposals made by Mr MCGREGOR ROSS yesterday. I don't know; this is obviously for you ladies and gentlemen to consider. But perhaps we could attempt to relate Dr MONACO's points of harmonization and standardization to the longer-term and the shorter-term considerations.

Mrs C. SCHWARTZ: I would like to return to the problem of the segmentation of the market. I feel we treated this question a



little too rapidly, for Mr de JONG said that broadcast videotex was only for the mass public market. Now the small professional user might also benefit from this service to a certain extent. At the present time, when we don't really know how the market is structured, we should not limit broadcast videotex to the general public only. Secondly, to get back to the question of standardization, I think we should take certain precautions. This is a highly technical subject. The proposal by Mr McGREGOR ROSS was very detailed and very difficult for a number of us. This should lead to an in-depth study, and I think it's rather difficult to discuss it here. I suggest we should take this document back home and study it very closely so that we can see how this relates to current standardization activities and the services in each individual country.

Mr E.J. FRENCH (ISO Central Secretariat): As most of you know, the work of ISO is decentralized. Technical work is conducted by technical committees... and, for this reason, I was delighted to find Mr McGREGOR ROSS here, making his excellent statement on the technical situation as regards character sets and codes. Mr McGREGOR ROSS is of course a member of ISO TC 97 Subcommittee 2 Working Group 4, which has been mentioned several times during this meeting. This working group was established in 1978, and it has already met three times, and it has produced, during this period, a third revision of a draft standard on these character sets for text communication... and I have just given Mr VERNIMB a copy of the latest draft. That, I think, is rapid progress as far as standardization is concerned, and indeed as far as international agreements are concerned. The report on the meeting of this group makes the point that many members and observers are also taking part in the teletex reporters' groups and the videotex working parties of the CCITT. Of course there is close liaison, in standardization, between all the international bodies concerned... and we try to ensure that there is no clash of interests, and some sort of priority in the work.

Mr T. SOMMERLATTE: I should like to take up the subject of standardization and videotex development, and try to link it up to the subject of Europe, from the point of view of the person who manufactures the final equipment. In Europe, at the present moment, there are about twenty-five manufacturers of television equipment, and it's very probable that, in some ten years time, only four of them will still be in the market. And these four manufacturers will only have sixty percent of the market volume, whereas the remaining forty percent will be supplied from outside Europe. And why exactly is this the case? I think that the answer is of interest to all of us within the framework of this discussion. The reason for this situation is linked to the notion of so-called economies of scale. This means that you need to produce at least one million pieces of equipment during the year in order to remain competitive. The same is probably true for

videotex, and of course these manufacturers will have to market their goods outside their own national frontiers in order to minimize costs. The same is true for the commercial area, i.e., the manufacture of videotex equipment for business users. I think that, if you were to ask the manufacturers (some of whom have representatives here at the meeting), they would admit that they have very little idea what the terminal should look like, or what variations should be proposed, or what information products should be offered to commercial users, and how they should be offered. Since the commercial terminals will inevitably have to be manufactured by an international group, then the whole question of standardization is of particular importance. The question of standardization is a matter of survival for the manufacturing industry.

Mr K. THOMPSON (CEC Directorate General III - Internal Market and Industrial Affairs): I have three points I would like to bring to the meeting, and ask some questions about. One is to stress the need for standardization from the point of view of the user, in the sense that the user is a mobile person, just as everybody here is mobile in order to have reached this place. We are finding more and more from our experience that this is an important feature, and I think that your figure of a quarter of a billion trans-border crossings per year in the Community area is an indication of that need... to standardize the user interface, so that when a user moves - I'm thinking now of sectors such as a farmer moving from one area to another, or a financier - he should not have to use different procedures because he's in a different country. The second point I would like to move on to follows up from Mr FRENCH's intervention. He said there was great progress in SC2/WG4. I'm a member of that group, as well as Mr McGREGOR ROSS, and I support very strongly the fact that there is great progress in that area. However I have to mention that, when I introduced the subject of testing, to see whether people were conforming to a standard, nobody at that working group meeting would join a subgroup on that topic. Now, how do you tell that your product has conformed to the standard if they are not written in such a form? I think that this is a very serious problem both for the consumer and for the supplier, because they cannot introduce terms into their contract of purchase or their contract of sale if the terms are not testable. The third and final point relates to the mass user. I have a telephone in my house, and it has become a potentially dangerous device... because it can spend money faster than I can earn it! At this moment somebody could be phoning Australia. You are asking me, as a user, to add another potentially dangerous device into my house, which I cannot control. And the more you can potentially earn from me, the more dangerous it becomes to me. I would therefore ask the following question. Shouldn't we have some standards, preferably on a European basis, whereby the user can control, in advance, not retrospectively, how much he's spending? I would be very interested in any experience from the PTTs in

this area, from their market studies.

Mr G. ANDERLA: This topic is related to the search strategy or technique of searching in these data bases. How many frames do you have to go through before reaching the one that is of interest to you? And you pay for all of them!

Mr A.C. NICHOLAS: I would like to speak of the conditions which would encourage information providers to come forward, and I don't apologize for raising this subject, because I think that the cost and complexity for them is being underestimated. The problem, here, is that information is undervalued, and that all of us feel that we have a surfeit of information. There is a problem here for suppliers making an investment in this area. Now I suggest that the conditions are, unfortunately, running rather counter to our discussions on standards, because an information supplier wants stability, he wants to know what his market is going to be, and he doesn't want change in his market. That is, he wants to be certain that what he does is going to be stable into the future. He wants, indeed, help on the structure of the market. (We have talked about that already, Mr Chairman.) He wants reasonable costs and tariffs, and this means a volume market. He wants assurance that the technology is stable... which is a very important matter. Now I suggest that technology is stable and workable enough, and that there is no problem at that level... but that the costs of the IPs are being underestimated. I think our colleagues from Prestel will probably admit that there are 160 IPs already, and there may be four hundred queuing up to provide. These are very large numbers of people, and large costs and investments are involved... and the return on these is going to be very small for a long time. They need to be given confidence that the technology they work with will have stability into the future, and I'm afraid that there will have to be trade-offs involved here between standards for national markets and international standards. We may well have to accept that, to encourage development, we must have stability for a while.

Mr G. ANDERLA: We seem to be moving away from the very classical dichotomy of standardization versus innovation - one must not prevent the other -, which is a recurring theme at all these conferences. Mr THOMPSON has spoken of the user dimension in the context of a more complex analysis, and Mr NICHOLAS has mentioned the concern of the publishers.

Mr H.J. BREIDENSTEIN: I am grateful to Mr NICHOLAS for his remarks, and I must say that I have been thinking along similar lines to him. I apologize in advance if I happen to sound a little provocative in what I am about to say. I have the impression from this morning's discussion that we are falling back into errors that, I thought, had been overcome yesterday. We are talking again, exclusively, about standardization, in such a way that we are not yet asking ourselves exactly what is to be standardized. We are faced,

here, with a new medium, and we have no idea at all what this new medium can provide. This morning we have heard attempts to work out market segments, and we have tried to explain what kinds of information could be put into the system, and someone said, quite rightly, that these systems have no limits, and that we should remain open to examining all kinds of applications. It's only once we've moved on from the field study to a practical stage that we'll be able to see where the emphasis should be put. It's only then, once we've reached that stage, that we can sensibly talk about standardization, because we'll know then what we have to standardize. In the publishing field, there's a major problem, namely, that all the information we offer in a traditional form must be transformed into this new structure. I was very interested when Mr MALIK said, for example, that what he needs is an encyclopaedia. Now I know a publisher who has put out an encyclopaedia in a classical form, and now he must completely re-edit the whole thing, which means years and years of work. And for this, he needs a certain degree of stability in the new system, before setting out on these years of investment. This is certainly one reason why there's a certain hesitation here. It's not a question of publishers being unwilling to take part in the system, but there's this major problem of what kinds of information can be put into such systems. Then there's another point that relates to something that Mr KANZOW said yesterday. It will be a great progress for publishers, in particular, if future videotex centres can in fact be linked up to computers outside the system. In other words, major data sources such as encyclopaedias will only be able to be introduced into the videotex systems if these systems can be brought into contact with the existing computers on which all this information is stored. It would be absurd if one had to introduce such information into a second computer memory.

Mr G. ANDERLA: I appreciate your two questions, Mr BREIDENSTEIN, namely: What do we standardize, and when do we standardize? There is no clear answer, obviously. It would be just as unreasonable to say that everything should be standardized, as to say that nothing should be standardized. It would be just as unreasonable to say that we must start standardizing at this present moment, as to say that we should never get around to standardizing. The answers are only possible in relative terms. The onus is to find the right balance and the right timing.

Mr J.F. PEDERSEN: I would like to comment on the remarks by Mr NICHOLAS and Mr BREIDENSTEIN. The first subject on Mr SIMPSON's agenda was the needs of the user. Up until now, at this meeting, we have spoken generally about the end-user, whether it be in the domestic or the business field. But, in my opinion, the IPs are also users of the system. In the telephone system, you have a calling party and a called party... and the videotex situation is analogous. So I think we have to take into account the needs of both parties when

we design such systems. The best thing, therefore, is to collaborate with both these parties during the pilot trials that we are going to start in most countries. We have also been referring, once again according to Mr SIMPSON's schema, to the short-term and longer-term contexts. I believe that we shall have to content ourselves with existing systems in the short term, in order to make these systems work in the best possible manner, and to acquire experience. In five years time, we shall have to work hard to create the second generation of systems... just as we have done in the teletex context: we started with group I and group II, and now we are at the level of group III. In the short term, we shall certainly see differences in standards between the countries. If we are to collaborate internationally, then we shall have to introduce some sort of converters between the various videotex centres... not for each user, but rather between the centres. With the advanced microprocessors of the future, it will become more and more easy to convert information between the centres, and cheaper too. And in the long run, we shall have to convert, not only between different standards, but also between the first generation and the second generation of videotex systems. We won't be able to stay very long with a transmission speed of 1200 bits per second; as telephone lines are becoming more stable, we should be able to move at least to 2400 bps. Mr SIMPSON then proposed that we consider the fields for collaboration, without taking the CEC into account. I think that standardization on techniques and operations should be handled within the CCITT and the CEPT. But I also think it's important for all the countries experimenting with videotex - either on a trial basis, or in an operational manner - to be able to exchange information about their plans and activities. For example: Who operates the systems? Where are the border-lines between the various parties? What are the legal conditions for the IPs, the PTTs, etc.? I think it's a pity that we all have to start from scratch instead of benefiting from the experience of the most advanced countries in this field. So I would encourage my colleagues from other PTTs to exchange information to a greater degree than in the past. The final item on Mr SIMPSON's list concerns the possible rôle of the Commission. I think that this meeting has confirmed that there is no urgency, as far as the CEC is concerned, at the level of the field trials, and that the questions of standardization are being handled by the CCITT and the CEPT. The CEC is free, of course, to see that this is done in a correct manner, and with the right timing. And if that were not the case, then I'm sure that Mr ANDERLA would call another meeting, and say a few words to us! But I think there's one area where you could do something more. I'm very impressed by the preparation of this meeting, and I'm very grateful for the initiative you've taken and for the information you have provided us with. As we heard, government bodies are now looking into the means of providing administrative and civic information through the videotex system, and I'm sure that this will be the case in the

government bodies of most countries. I feel that the CEC could look into the question of the form in which data from the Commission might be structured, so that it could be sent to all Community countries, and distributed to the public. In other words, how can information be tailor-made for the most ideal presentation to the public? And in each country, the only thing to be done would be to translate that information into the national language. That could be a nice CEC task for, say, the next two years.

Mr J.M. HARPER: I would really like to support practically everything that Mr PEDERSEN said. I am sure in my own mind that the right, main continuing axis for the standards work is in fact the CCITT and the CEPT. I think that the sort of relationship which developed at Mr DAVIGNON's recent meeting in Brussels - where the CEC is in fact the policeman who looks to see that the CEPT and the PTTs are proceeding at the correct speed - is the correct sort of relationship on the standards front. I am personally quite struck with Mr PEDERSEN's perception that the Commission is, at it were, an information provider, in the same way that Mr THYNNE described the British government as being an IP. And I would commend that, personally, to your attention. Finally, it appears to me that it is no accident that this morning's discussion has consisted considerably of comparisons of what little we know or think at present about the markets. It seems to me that you have done a service to many of us in providing this opportunity, and that the Commission might well consider providing similar opportunities in the future for people to compare notes on this sort of thing. The subject is broad, and it contains such a degree of uncertainty, that I think you have done the whole Community a service by giving us these opportunities to meet up with one another.

Mr O. TCHERNIAK: I would like to refer to what our British and Danish colleagues have just said. The bodies that are most concerned with standardization are, I agree, the CCITT and the CEPT. Furthermore, you mentioned just now the interest of pooling experience, and this is quite true. But, if we restrict these meetings to Community countries, we may lose sight of the views of countries such as Sweden and Switzerland, which are involved in the CEPT and the CCITT, where they can participate fully in all the discussions concerning videotex standardization.

Mr H. McGREGOR ROSS: I would just like to inform the meeting that, within the British Standards Institution, we have set up a special technical committee to review the whole question of standards needed for text communication, and therefore including the standards needed for videotex. This work has originated in Britain, but we have already informed all the other Community national standards bodies of this initiative through the working group on standards which is under Mr LAYTON's responsibility. The committee in Britain has met a

number of times already, and is making very good progress in identifying the areas which might usefully be standardized, and those which preferably should not be standardized. We do this work, of course, in co-operation, not only with the Community national standards bodies, but also with the ISO. I'm very hopeful that this work will prove very valuable and that, through the already established links of the CEC, it will be brought quickly to the notice of the other European countries. I should also add that the working group on standards, under Dr LAYTON, does maintain links with the other main European countries which are not members of the Community.

Mr G. ANDERLA: Before the next speaker, let me just remind you how we handle the question of third countries within the Euronet context. The consortium of the nine PTTs was set up under the aegis of the CEPT. All the time, all the other non-Community countries were invited as observers - or were welcomed to participate actively in the case of the Swedish, the Spanish and others - in all the discussions. As of late, of course, the Council has given the Commission a mandate to open up Euronet formally, by way of negotiating agreements, to all CEPT members... and we have just concluded one such agreement with Switzerland, and we are very close - I hope - to coming to similar agreements with Sweden and Spain. Austria has also sent a similar diplomatic note, but we didn't have former contacts with them. So, this shows that this problem of third countries with respect to the Community, within the CEPT family, can easily be dealt with.

Mr C. de JONG: I wish to endorse the views expressed by Mr PEDERSEN, Mr HARPER and Mr TCHERNIAK. That is, technical questions should be left to the CCITT and the CEPT, whereas the Commission could carry out the two functions already mentioned, namely, to act as an information provider, and to play the rôle of a "policeman".

Mr H.D. SCHOLZ: An important subject that is emerging from the discussions is the question of stability: stability for the IPs and stability for the manufacturers. And I think it's very important indeed to return to the question of how to achieve stability in such an ever-changing environment, where what is technically feasible is going to change tremendously in the next few years. Some of the discussions on standardization gave the impression that a black-or-white solution was required... but I think it's important to open up perspectives to the users, the manufacturers, the suppliers, so that people will be induced to move together in order to achieve stability, which is very important for the parties concerned.

Mr M.L. FORD: I would like to take up this point of stability, in particular, and one or two other points if I may. I also believe that it is extremely important that we should maintain stability in the introduction of these

services. And we have been very conscious, all the way through the development of Prestel, of the need to do this, and of the need to keep constantly in mind the requirements and needs of three groups of people: two users, referred to by Mr PEDERSEN, namely the end-users and the information providers, and also the manufacturing elements involved here. It may be of interest to the meeting to know that, throughout this development, we have had a co-operative group which has been the steering group for what was to become the Prestel service, which has comprised initially members of the Post Office, members of the manufacturing industry and members of the information industry in the United Kingdom. Now that we have moved into the service phase, we have formalized this group, which we call the Prestel Liaison Group, and it now consists of five members in each of those three areas, plus the chairman of the meeting who is the director of Prestel. We believe that we need to bring in the end-user at some stage. But, at the moment, it is not quite clear how that end-user should be represented. We do have, amongst our IPs, the Consumers' Association, which protects the interests of the consumer in a wide variety of areas... and they are very conscious of this need and, at the moment, are acting in this dual control position. So, we have found it very necessary to keep up a very open discussion with all the parties to this type of service, and I do recommend that to other PTTs when they are introducing this service, so that these people can make their contribution to the overall plans for the development of the service, and they very much reflect to us the need for this type of stability. We ourselves are very conscious of this, and our own plans are very much based on the fact that we need to evolve quite slowly in this service, and when we want to see change, we need to balance the benefits of improvement against the cost of that change and the effect of that change upon our users. And we do believe that we can do this; we want to have a compatible evolution, so that we won't have abrupt changes. We want to make sure that the users who come into the service now will be able to continue to use the service for a long time ahead, although we may well introduce improvements which they may or may not wish to take up. All this is very important, and I believe that we in the UK are working in the right direction on this. Let me now return to two points that Mr THOMPSON made. The question of user interface standards has been looked at in the CCITT. It hasn't been getting the publicity that the technical standards have had, but a lot of work is being carried out in this area to try to introduce a basic standardization of the user interface in these systems. Finally, there is his question of how we are going to control the use of these systems so that he is not going to spend a great deal of money without knowing it. We have been also very conscious of this problem. Our approach is slightly different to the one he suggested. We do in fact make it possible to look at your bill at any time when you're using the system. It is absolutely up-to-date. And we have an optional password facility so that, if you have a set, you



can at any time insert a personal password into the system so that only you can use that system, and you can change that at any time you like, because it is completely under your control. This is a very valuable facility for people who might be worried that their children, or maids, or visitors might use the system and run up a bill.

Mr R. MALIK: There are a number of things I would like to support, and they will come out from the context of what I am saying. Mr BREIDENSTEIN put his finger on something this morning, and I have been waiting for someone to say it. I think it does very well sum up some of the difficulties we have been having. He used the term "a new medium". It seems to me that there is a split, and it has been quite evident in our discussions, between those who think in terms of videotex being a new medium, and those who are somewhat uncomfortable because they may feel that there may be "something out there"... but they are trying to apply rules from existing media. If it's a new medium, then new rules apply. Now, we have in fact, in history, been in this situation before. Henry Ford went and changed the total face of the industrialized world by the invention of the mass-produced motor-car. And where would we be, today, without the Xerox process? Videotex obviously has to have a European dimension. After all, you can truthfully say, in practice if not in theory, that it's a medium invented and devised in Europe. I wish, once again, to support the schema put forward by Mr MCGREGOR ROSS, because it seems to me that it doesn't matter which view you take - whether this is a new medium, or an extension of existing practices - it fits underneath this umbrella. Secondly, it seems to me that, if it is a new medium, and a European medium, then obviously the Community must have a rôle to play. There really ought to be a European dimension. And if there is a European dimension, then what is it? Several areas have been mentioned. I suspect there must be more... and this is an area where, I think, the Community could take the lead.

Mr E.J. FRENCH: I think there is a great deal that everyone here can do, either in the absence of the Commission, or even if the Commission is there. Unfortunately, I can't speak for the CCITT, and they are not here to speak for themselves. But perhaps I can say a few words on behalf of ISO. I imagine that almost everyone here in this room has a relationship with his national standards body. Many of the organizations represented here are in fact members of their national standards bodies. Some of the governments represented here support these national standards bodies financially and in other ways. So, clearly you have a rôle to play in ensuring that we get good standards, that good standard are published, and that bad standards are not published. And the only way you can do this is by taking an interest and taking a part in the standardization process. Many of the comments made on standards here were very general. They apply to almost everything that's standardized, but they apply equally to

videotex. The idea that standards may hold up development is a general point, and that's why, when standards are written, the emphasis is on performance and on interchangeability rather than on design details. Perhaps the slant could be in this direction. I don't know how this fits into the videotex picture. But if we can concentrate on performance standards and interchange standards, then perhaps this is a move in the right direction. It's up to you to say. You are the people who determine the need for standardization, what's wanted, and what the priorities are. It's not the standards body that does this; it's the people who control the standards body, who make their requirements known to their standards bodies, and through the national standards bodies to the international standards bodies. If the Commission is present, I think it has a very great part to play. Mr THOMPSON has said he's already helping to play this part by working with Subcommittee 2, Working Group 4 of Technical Committee 97. He also mentioned testing of standards. Perhaps in the time scale, this comes after the development of the standards, but most standards bodies already have machinery for ensuring or checking the implementation of standards, for certifying the implementation of standards by manufacturers. Perhaps all of you would be well advised to check with your standards bodies what machinery there is, and how it can be applied in your particular cases.

Mr K. PANDEY: I would like to return to Mr SIMPSON's original subject, which was a question of timing. And I would like to propose a strategy for the Commission to follow. It seems to me that there is sufficient commitment from various organizations for them to resist and be fearful of standardization here and now. I feel that standardization can only take place in a longer time frame. So, if the Commission said that the intention (and this does not mean that it is the Commission that is necessarily enforcing the intention) was to standardize something in the longer time frame - say in the three to five year time frame, so that in the three year time frame you would decide what it is that needs standardization, and get the appropriate bodies to do the standardization of it, and produce a control and monitoring system whereby the Commission could ensure to its satisfaction that these timetables were being followed -, then I think it would provide the calm feeling that industry is looking for, in which it could proceed at a fast rate.

Mr L. SMULIAN (CEC Directorate General III): I think it would be worthwhile to clarify the Commission's present rôle, and what we see as our future rôle, in this area of the standardization of what are essentially services, public services. It's not our intention to demand of anybody that they standardize anything. It is however our intention to try and ensure that, when new services are provided which are Community-wide available, even if they are provided nationally, they should be provided in such a way that they are harmonized, compatible, that inter-working is possible,

and that the way in which they are implemented does not prevent their evolution on a common basis. That's to say that the responsibility rests upon the member states - and thus becomes a requirement of the member governments - to collaborate in trying to ensure that harmonization is carried out constantly to the extent that there is not the possibility, as a result of their actions, of systems being developed which cannot evolve at a Community level.

Mr K. PANDEY: I feel that Mr SMULIAN has just defined what I said the Commission should take three years to do. It's a matter of defining what is the range of standardization, and what are the interests of the Commission. Many other questions have been asked about standardization: about formats, about information providers, about linking to data systems, and so on... Whether these things need to be standardized, and who will do it... These are the questions that I have proposed that the Commission should look into over a three-year time frame.

Mr J.M. HARPER: The thought that was going through my mind was really quite simple... and I'll speak at a telecom level rather than at a videotex level. There seems to be a consensus among the Community PTTs and with yourselves that we have to move towards the harmonization of services. Our discussion has identified videotex, I think, with as much clarity as is possible at a European level, as a service which requires standardization attention. The basic pattern which has evolved in the last hour is that we have identified a service which requires a degree of standardization, and that this standardization should proceed at first through the CEPT and the CCITT machinery. And this is entirely consistent with the more general pattern that emerged in Brussels a month ago.

Mr J.K. POVALL: One final comment on the question of standardization. First of all, I would say that it's a matter of standardization from the user's point of view, and not from the manufacturer's point of view. I can't see that the availability of general standards is going to help my company very much in selling sets. I disagree with Mr SOMMERLATTE on that question. The thing that I'm surprised that nobody has mentioned is the question of standardization insofar as it affects charging for the service... and I'm surprised that nobody from the PTTs has come up with this question. How on earth are you going to charge a customer in the UK for the use of the French system, for example? This would seem to be a bigger problem than the question of simply standardizing interfaces.

Mr M.L. FORD: The questions of charging, and of how you charge, are one of the many problems of the inter-operability and the operation of these services on an international basis... which the PTTs are looking at and studying. We don't stand up and shout a lot about it, but this is all going

on... in the CEPT and the CCITT. There are very real problems involved here, which can be solved, and it is quite clear that there will be a need for the inter-connexion of national videotex systems, not only within the Community, but on a world-wide basis. This is what the PTTs within the CEPT and the CCITT are working on: the whole range of problems associated with this. And we have only really, today, picked up a few of the areas where, in terms of standardization, this agreement needs to be reached. And I do assure the meeting that this work is going on, slowly but steadily. As the need for results increases, so the pace of the work will increase. Finally, I would like to say something about the suggestion that the Commission should be looking into the question of standards over a three-year period. The confidence of the users, and the question of stability, have been mentioned quite a lot. Users - both end-users and information providers -, as well as manufacturers, are going to hold back as long as they feel that certain things need to be standardized before services can operate. Based on the report of what happened at the CEPT meeting last week, I don't think there is anything that needs to be done on standards any more, before any of these services can be introduced. And I believe it's very important, when presenting to the general public and to our users the question of standardization, that we present a proper picture, and don't let them feel that there's still some enormous problem that has to be solved before they can have the confidence to move in and operate these services.

## CONFERENCE CONCLUSIONS

*Mr. G. Anderla*

At the end of yesterday's presentations and discussions, it was obvious that there is a very large consensus of opinion on a number of points. We started talking about this conference many months ago, but I never anticipated that so much could be achieved. I believe there's a clear agreement that Europe holds, for the moment, the leadership in this new technology, and that, after the pioneering efforts of some, we may be faced with a rather bright future. The future offers considerable opportunities to several sectors of our society, but it also presents certain dangers. We seem to have started mapping out the road to developments that will benefit all the participating partners. The second point which strikes me is that there is a need for more fact-finding, particularly concerning user needs: more studies, better methodologies, motivational studies, evaluation of segmentation criteria, etc... and the corollary is that there is a great need for exchanging whatever information is available on the one side and on the other. This should occur within the PTTs themselves, of course, but also between the PTTs and the other "players". I am not going to repeat what I said in summing up the discussion on the user needs, market problems, segmentation aspects, and the overlapping between the national and international markets and needs, and the local ones. Frankly, we don't know enough about it. We don't know enough about what the user will eventually want. We must find out... The second theme proposed to us by Mr SIMPSON was product development. It is clear that the product will change; it's bound to change... and you had better see to it that the product changes in such a way that it becomes more acceptable by the market. That is the only obvious thing to do: allow the user to retroact with you. I think we are moving from the first generation - rather primitive systems, clearly with many constraints (design of the frames, information content, data base supply, etc.) - to something much more interactive... from the off-the-shelf type of application (as Mr THYNNE suggested) to the individual problem-solving application, if that can be achieved. Then we move to the areas of short-term and long-term developments. Certain things should be done quickly, whereas others should wait... and the discussions, obviously, centred around the subject of standardization. I felt a slight frustration there because I would have thought that the discussion should have ranged more widely, because it's not just standardizing that's involved, but also harmonizing certain things, and moving closer together... in

data base design, in software to be provided, in common command sets, making it easier for the user. I would have thought that these problems should be approached from a broader point of view. However, on the evidence of the discussion, it seems to me that, collectively, you have suggested basically seven "golden rules" concerning what standardization should, or should not, mean. You might call them conditions. I think the very first condition is that we must not prevent innovation. We must not stop the creativity... and, from creativity, the industrial applications it gives rise to. Second, it must provide for stability... or at least relative stability, I suppose, for surely, at this stage, nobody can foresee what will happen in twenty years' time. Stability is needed by the suppliers, and reasonable stability is needed by the users, and by the providers of the links between them, i.e., the PTTs. I think the third "golden rule" is that one should only (as Mr LAYTON suggested yesterday) standardize what it is absolutely necessary to standardize. It should be limited, in other words, to the essential aspects. One should not be tempted to standardize merely for the sake of standardizing, or of harmonizing. Much more work is required in order to define the range of problems to be tackled in this field. In the short term, I consider standardization to be a hopeless undertaking. Too much has been committed, on many sides, to what exists today... and it would be completely foolish to ask such-and-such a country, or PTT, or industry, or group, to give up what they're doing, for the sake of some problematical future benefits... which there may be. No prudent businessman would act that way. We know that the product is still in its infancy; there will be a second generation, a third generation, etc... So, if three people, today, find themselves, respectively, in positions A, B and C, there's no sense in asking them to move... but they may be enticed by the prospect of getting, say, into position D, in five years' time. What is the correct time framework for these questions? The answer to this question must come from the PTTs and the other partners, but I'm sure that there will be a second generation of systems, and it's much easier to agree upon what should exist in the future, and to then bring it gradually about, than to impose drastic changes at the present moment. If I may be permitted to express a side remark, I would like to point out that it is, above all, in the medium term that the Community has been most successful. It has almost always failed in the short term, dealing with monetary policies and crises. And it is very hazardous when we come to ten-year or twenty-year policies, because it's difficult to carry out crystal-gazing in the European context. But, in the medium term, the Community has managed to develop a set of inducements and techniques to handle transitional periods, gradual changes and "pain-free" calendar scheduling. The fifth "golden rule" is, I think, that all interested parties should be listened to... and particularly the information providers. The PTTs, above all, should listen to these IPs... and there's also a need - as Mr

NICHOLAS and Mr THOMPSON have suggested - for a user forum to listen to. Their requirements should be increasingly taken into account. It is clear ("golden rule" n° 6) that the appropriate bodies should be used to the maximum possible extent: the CEPT, ISO, CCITT... I repeat what Mr DAVIGNON said, upon which everyone agreed, namely that the Commission claims no leading rôle in these affairs... but we will be rather vigilant to see that these bodies do in fact move ahead at a speed commensurate with technological change. The Commission, in other words, can be seen merely as a sort of "court of appeal"... if everything else fails. We have no wish to supersede or replace or duplicate - in any way whatsoever - what other people are more competent to do. Finally ("golden rule" n° 7), I believe that future standards - for a period of, say, five years from now - towards which we must start working, should, as far as possible, be compatible with present-day standards. This is Mr FORD's point, basically. It's not always 100 percent possible, but it should be the goal, and it certainly should imply that, whatever changes there are between the first and second generations, changes in standards should be minimized. Then several speakers turned to matters of collaboration between the interested parties, irrespective of whether the Commission, as the executive organ of the Committee, plays any rôle at all. Several speakers made in fact very clear references to this. Within the PTTs themselves, it was said that information flow should be better organized, and that information exchange should take place actively. It is quite obvious, from this conference alone, that there has not been enough communication between the PTTs and the IPs. I think that this is perhaps one of the most striking findings of this conference. This is a gap to be filled, and I would strongly urge the two partners to move closer together, and to organize their concertations and their exchange of views. Then there is the question of one's relationships with the users. It's true that as long as there was no product to test, only blueprints, it was difficult to start such a dialogue. But we ourselves, in the Euronet context, have found it most useful to launch a number of user forums, at which the users should be encouraged to express their views freely, even if you may not like them all the time. The final point on Mr SIMPSON's "shopping list" was whether, and to what extent, and on what particular points, the Community as such - and the Commission in particular - should be involved. It is true that I have slightly misstated the case in my opening remarks... and Mr SMULIAN quite properly reminded me that there is a directive from the Council to the Commission to investigate ways of finding solutions to the three critical aspects of telecommunications policies, namely: standardization and harmonization; secondly, the procurement policy, i.e., the gradual opening up of domestic markets to products from the other member countries; and finally the tariff policies. I, personally, do not believe that directive can be imposed. It would be foolish to do so. These recommendations can only be concretized, and results

achieved, at your wish and at your request. As a minimum, your full co-operation would be required. All the rest is wishful thinking... whether it comes from the ministers, if I may say so, or not. You cannot force partners to co-operate if they don't want to. But we have tried. Here again, I would like to quote the Euronet example. In Euronet, we have achieved all these three objectives, in a painless manner: by friendly discussions, we have unified the technology on packet switching, we agreed on the call of tenders to the international consortium, and we have defined a unified distance-independent tariff. Why not continue in the same way? I would make only one exception, perhaps, to this. We are a community of nine countries, and possibly more tomorrow, and six languages... and the Community as such must see to it that the language barriers, the communication barrier (not the telecommunications, but the communications, barrier), from man to man, must be lowered. That includes, of course, our concern for all sorts of devices, techniques, translation facilities, multilingual dictionaries, as well as multiple set representations... which is a unique job that the Committee must undertake for its own sake and for the benefit of the whole population. Now, what else has been suggested, besides these generalities? Clearly, at the standardization and harmonization level, the Commission is ready to co-operate with you and to assist you... if you so wish, and if the other bodies do not perform as desired (but I hope they will). In the domain of data base design - i.e., improvements to product styling, and definition of languages for the command sets - we have acquired, with our friends from the CIDST, a certain degree of expertise, which we would gladly share with others, particularly the publishers and other IPs. We shall certainly look into the possibility of opening up Community data bases. For example, the Commission has one large data base that contains 900 thousand statistical series, updated either weekly or monthly, and located here in Luxembourg. We are opening it up to the general public through Euronet, and some of it might be of interest to the business community through videotex. Something might be done in the field of unemployment, particularly between neighbouring countries. More generally (and this has been said several times), I think that the CEC can provide a forum for discussion, whenever such a forum is wanted. This fits in with Mr HARPER's last remarks. Well, it seems to me that those are aspects and problems on which there is probably some disagreement, but not much. I don't claim that these subjects constitute a strategy, not even the outlines of a strategy, but they seem to map out a road towards a more co-operative approach to all these complex issues that are involved in videotex and other related technologies. My final remark will be to say that you have been a most wonderful audience... Thanks to all the conference organizers, etc... The conference is now closed.



FINAL  
LIST OF PARTICIPANTS

in the VIDEOTEX Conference  
19 and 20 June 1979

Jean Monnet Building, Kirchberg - Luxembourg

Room M 4

BELGIUM

Mr. R. ANCIAUX

Secretary general  
Group of National Travel Agents' Associations within the E.E.C.  
Rue des Colonies, 28 - Bte 5  
B-1000 Brussels

Mr. Ir. G. ZWAENEPOEL

Attaché Technology Dept.  
Ministère des Affaires Economiques  
8, rue de la Science  
B-1040 Bruxelles

Mr. J. LEURS

Chef du Cabinet du Ministère des PTT (1st day only)  
56, rue de la Loi, 1040 Bruxelles

Mr. J. STYNEN

Bell Telephone, Francis Wellislaan N° 1  
B-2000 ANVERS

DENMARK

Mr. Erik BONNERUP NIELSEN

Permanent Undersecretary  
Finanzministeriet, Administrationsdepartementet  
Holmens Kanal 20<sup>3</sup>,  
DK-1060 Kobenhagen K

Mr. Jorgen F. PEDERSEN

Telecommunications Directorate  
Anker Heegaards Gade 4  
DK-1503 Kobenhagen V

FRANCE

Mr. O. TCHERNIAK                      Mission aux produits et Services nouveaux  
Tour Maine - Montparnasse  
33, Avenue du Maine, bureau 2217  
F-75755 Paris Cedex 15

Mr. E. ALIZON                              THOMSON - CSF  
B.P. 700-08  
F-75360 Paris Cedex 08

Mr. F. ANGUERA                            Inspecteur Général  
France Régions FR3  
5, Avenue du Recteur Poincaré  
F-75782 Paris Cedex 16

Mr. K. PANDEY                             TEXAS INSTRUMENTS Ltd.  
B.P. 5  
F-06 Villeneuve-Loubet

Mrs. Ch. SCHWARTZ                        CCETT, 107 avenue de Crimée, B.P. 2276  
F-35022 Rennes Cedex

Mr. N. NAFFAH                             IRIA, Domaine de Voluceau, Rocquencourt B.P. 105      (1st day only)  
F-78150 Le Chesnay

Miss M. AUNE                                TDF (Télédiffusion de France), 21-27 Rue Barbès,  
F-92120 Montrouge

Mr. J.F. SOULAT                            PACTEL France, Computer Siemens Mgr., DG IX  
58, rue Glesener, Paris

GERMANY

Mr. H. DRUECK

Westdeutscher Rundfunk  
Appellhofplatz 1, D-5000 Köln 1

Mr. H.J. BREIDENSTEIN

Brönner Umschau Breidenstein K.G.  
Stuttgarter Str. 18-34  
D-6000 Frankfurt / Main 1

Mr. H. TAEGE

Siemens AG, Unternehmensbereich Fernschreiben und  
Datenverkehr, Hofmannstrasse, 8000 München 70

Mr. K.H. VOEGE

Nixdorf Computer A.G., Fürstenallee 7  
D-4790 Paderborn

Mr. J. KANZOW

Ministerialrat, Dipl.-Ing.  
Bundesministerium für das Post- und Fernmeldewesen  
Adenauerallee 95-97, D-5300 Bonn-Bad Godesberg

ITALY

Mr. U. MONACO

Direttore Generale delle Poste e Telecomunicazioni  
Viale Europa 160  
00100 Roma

Mr. P. BALDONI

Stet Societa Finanziaria Telefonica, P.A.  
Via Aniene 31, 00198 Roma

Mr. E. PASCALE

S.I.P., Societa Italiana per l'Esercizio Telefonico  
Via Flaminia 189, 00196 Roma

Mr. F. CORRADI

Olivetti, Via Gervis 77, Ivrea (Torino)

LUXEMBOURG

Mr. J.P. JACQUOT

European Investment Bank  
2, Place de Metz  
Luxembourg

Mr. J. HEINEN

Director, Administration des PTT, Techn. Division  
B.P. 2061, 17 rue de Hollerich  
Luxembourg

THE NETHERLANDS

Mr. R.E.M. van der BRINK

Chairman, Stichting Moderne Media  
Herengracht 257  
NL-Amsterdam

(replaced by Mr. H. DAVIDS, S.M.M.  
the 1st day)

Mr. C. de JONG

Deputy Senior Director  
Netherlands Postal and Telecommunications Services  
Headquarters,  
Kortenaerkade 12  
Den Haag

Mr. J.F. BROUWER

Philips' Telecommunicatie Industrie B.V.  
P.O. Box 32  
NL-1200 JD Hilversum

UNITED KINGDOM

Mr. J.M. HARPER

Assistant Managing Director  
Post Office Telecommunications, Headquarters  
2-12 Gresham Street  
GB- London EC2V 7AG

Mr. R. MALIK

107 North End Road  
London NW11 7TA

Mr. J.K. POVALL

Product Planning Manager  
Plessey Telecommunications Ltd.  
Edge Lane  
Liverpool L7 9NM

Mr. J. THYNNE

Computer Systems and Electronics Division  
Department of Industry  
123 Victoria Street  
GB-London SW1E 6RB

Mr. R. SCOTT

Deputy Managing Director BBC Television Service  
Television Centre Wood Land shepherds Bush,  
London-W12 8 QT

Mr. M.L. FORD

Deputy Director of Prestel  
Prestel Headquarters, British Post Office  
Telephone House Temple Avenue,  
London EC4Y OHL

INTERNATIONAL

Mr. E.J. FRENCH

Head, Information Centre ISO Central Secretariat  
1, rue de Varembé / Case postale 56  
CH-1211 Genève 20

CIDST (Committee for Information and Documentation on Science and Technology)

Mr. M. CREMER

Chairman of CIDST  
Bischofsweg 31, D-6000 Frankfurt/Main

(1st day only)

Mr. A.C. NICHOLAS

Chairman of ETAG (European Technical Aspects Group)  
Department of Industry, Research and Technology Requirements and  
Space Division, Branch 3, Abell House, John Islip Street  
London SW1P 4LN

Mr. W.L. RENAUD

Nederlands Orgaan voor de Bevordering van de Informatieverzorging  
Afdeling Buitenlandse Betrekkingen, Burgemeester Van Karnebeeklaan 19  
Den Haag

Mr. CHAMBAUD

Bureau National d'Information Scientifique et Technique - BNIST  
8-10, rue Crillon, F-75194 Paris Cedex 04

CONSULTANTS

Mr. J. STANFIELD	PACTEL, 33 Greycoat Street, London SW1P 2QF
Mr. I. McLAREN	PA Design Unit, 48-49 Princes Place, London W11
Mr. H. SCHOLZ	PACTEL, Mendelssohnstr. 53, D-6000 Frankfurt/M. 1
Mr. K. SIMPSON	PA International, Rutland Gardens, Rutland Gate Knightsbridge, London SW7 1BY
Mr. H. McGREGOR ROSS	Data System Consultants, 5 Kingsley Place, Highgate London N6 5EA
Mr. R. WOOLFE	Butler Cox & Partners, Moreley House (5th Floor) 26-30 Holborn Viaduct, London EC1A 2BP
Mr. R. BARNES	MWS Services, 11-12 Pall Mall, London SW1Y 5LU
Mr. M. KOHN	Telesystèmes, Tour Vendome, 390 Rond-Point du Pont de Sèvres, F-92516 Boulogne-Billancourt
Mr. M. ROETTER	AD Little, 230 Rue du Faubourg St. Honoré F-75008 Paris
Mr. T. SOMMERLATTE	AD Little, 34 Abraham Lincoln Strasse, 62 Wiesbaden
Mr. W. SKYVINGTON	23, rue Rambuteau, F-75004 Paris



COMMISSION OF THE EUROPEAN COMMUNITIES

---

Directorate General XIII:  
Scientific and Technical Information  
and Information Management

---

Mr. R.K. APPLEYARD  
Mr. G. ~~ANDERLA~~  
Mr. J. LANNOY  
Mr. A. MAUPERON  
Mr. H. KRONZ  
Mr. J.M. GIBB  
Mr. B.B. GOODMAN  
Mr. G. DAVIES  
Mr. A. DUNNING  
Mr. B. MAHON  
Mr. J. THOMAS

Directorate General III:  
Internal Market and Industrial Affairs

---

Mr. Ch. LAYTON  
Mr. L. SMULIAN  
Mr. K. THOMPSON

Statistical Office

Mr. D. BYK

Secretariat

Mr. C. VERNIMB  
Mr. R. HABER  
Mr. G. LINKENHEIL  
Mrs. R. STOUT





